

2012 Legacy



Subaru of America, Inc., Subaru Plaza,
P.O. Box 6000, Cherry Hill, NJ 08034-6000



MSA5B1203A
Issued July 2011
Printed in USA 09/11

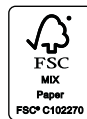

Quick Reference Guide



Complete U.S. specifications and illustrations may not have been available at time of publication. Specifications are based on the latest product information available at time of publication. Some images shown are for illustration purposes only. Some equipment shown may be optional at extra cost. Specific options may be available only in combination with other options. Specific combinations of equipment or features may vary from time to time and by geographic area. Certain accessories and equipment may not be available at the time of publication.

This Quick Reference Guide applies to all Legacy models. Therefore, some explanations may be for equipment not installed on your vehicle. Subaru of America, Inc., reserves the right to change or discontinue at any time, without notice, prices, colors, materials, equipment, accessories, specifications, models and packages without incurring any obligation to make the same or similar changes on vehicles previously sold. Colors shown may vary due to reproduction process.

For detailed operating and safety information, please consult the Owner's Manual.

Subaru, Outback, Legacy, Forester, Impreza, WRX, WRX/STI, BOXER, SI-DRIVE, Lineartronic, Alcantara, XM and Sirius are registered trademarks.

All rights reserved. Contents may not be reprinted or electronically reproduced in whole or in part without prior written approval of Subaru of America, Inc.

© 2011 Subaru of America, Inc.

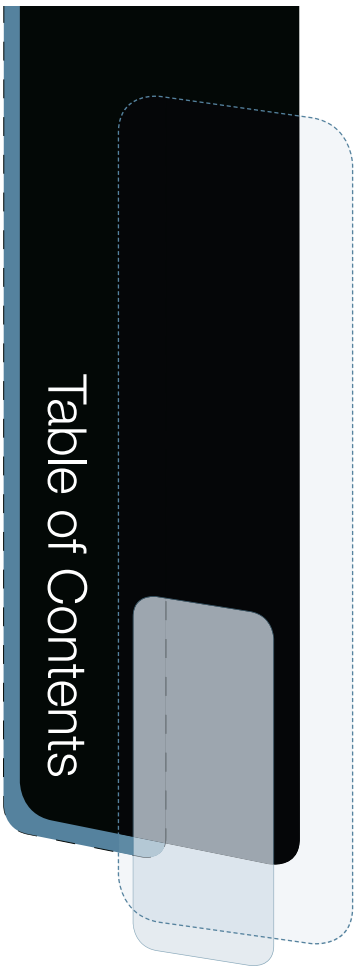

Table of Contents

Getting Started	○ 2 - 3
Instrument Panel	○ 4 - 5
Gauges	○ 6 - 7
Personalize	○ 8 - 9
Controls	○ 10 - 21
While Operating	○ 22 - 23
Safety/In Case of Emergency	○ 24 - 25
Additional Information	○ 26 - 27

Remote Keyless Entry

Lock/Arm

- Press to lock all doors and trunk and activate the security alarm.
- If any of the doors or the trunk are not fully closed, an electronic chirp will sound five times and the hazard lights will flash five times to alert you that the doors or the trunk are not properly closed.
- To activate the vehicle finder function, press three times (within five seconds). If you are within 30 feet of the vehicle, the horn will sound one time and the hazard lights will flash three times.



Unlock/Disarm

- Press once to unlock the driver's door.
- Press twice (within five seconds) to unlock all doors.
- When the "Unlock/Disarm" button is pressed, the dome and map lights will illuminate if the dome light switch is in the middle position.

Opening the Trunk Lid

Press and hold to unlock the trunk lid. An electronic chirp will sound twice and the hazard lights will flash twice.

Panic Alarm

- Press once and the horn will sound and the hazard lights will flash.
- Press any button on the remote to deactivate.

Immobilizer

When the security alarm is activated, the immobilizer interrupts the starter motor to prevent an intruder from starting your vehicle without a registered key.

Seating

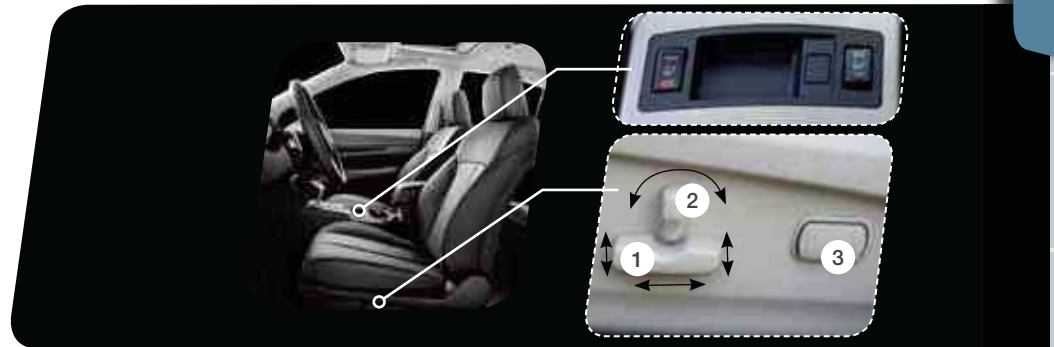

Heated Seats (if equipped)

Press the switch in the corresponding direction for the desired seat temperature. To turn off the seat heater, slightly press in the opposite direction of the current position.

Rear Seat Release Lever

Open the trunk lid. Pull the release lever on the seat side that you want to fold down. To return the seatback to its original position, raise the seatback until it locks into place making sure that it is securely locked.



10-Way Power Driver's Seat (if equipped)

1. Forward/Backward, Angle and Height

Move the switch toward the front or rear to move the seat forward or backward. Pull the switch up or push down on the front of the switch to adjust the angle of the seat cushion. Pulling the switch straight up or pushing the switch straight down will adjust the height of the entire seat cushion.

2. Seatback

Move the switch in the corresponding direction to adjust the angle of the seatback.

3. Lumbar Support

Press the front part of the switch to increase lumbar support; press the rear part of the switch to decrease lumbar support.



Instrument Panel



pg. 22 pg. 8

pg. 10 pg. 20

pg. 6-7

pg. 21

pg. 11

pg. 12-15

pg. 16-19

Clock

Press the "+" button to advance time or the "-" button to reverse the time. Vehicles with a navigation system, please refer to the separate "Operating Instructions for Navigation System."

























Gauges

■ Immediate Attention

■ Caution

■ Informational



 Seatbelt warning	 Hot coolant temperature / Cold coolant temperature	 Vehicle Dynamics Control/Vehicle Dynamics Control operation	 Hill Holder
 Front passenger seatbelt warning	 High beam indicator light	 Vehicle Dynamics Control OFF	 Turn signals
 SRS airbag system	 Engine oil level warning	 CHECK ENGINE / Malfunction indicator	 Front fog light indicator light (if equipped)
 Security indicator light	 AT OIL TEMP (Automatic Transmission)	 Tire pressure warning light	 Headlight indicator light
 Charge warning	 ABS / (ABS) ABS warning	 ON / (airbag) Front passenger frontal airbag ON	
 Oil pressure warning	 Low fuel	 OFF / (airbag) Front passenger frontal airbag OFF	
 BRAKE / (Brake) Brake system	 AWD All-Wheel Drive (Automatic Transmission)	 Low windshield washer fluid	

Personalize



Tilt and Telescopic Steering Column

Push the lever down firmly to adjust the height and lengthwise position of the column; firmly push the lever back up to lock the column in place. Do not adjust while driving.

Power Exterior Mirrors

Turn the knob to the “L” side to adjust the left-hand mirror or to the “R” side to adjust the right-hand mirror. Move the knob in the direction you want to move the mirror. Then return the knob to the neutral/center position.

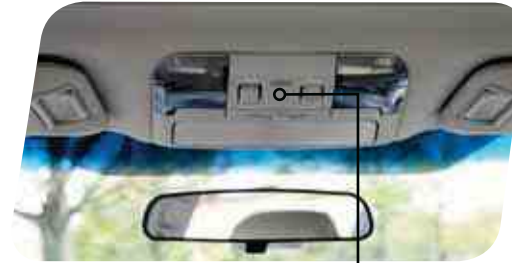

Power Moonroof (if equipped)

With the moonroof in the fully closed position, press the switch ② to tilt the rear of the moonroof up. Press and hold the switch ① to lower the moonroof. Press the switch ④ to fully open the moonroof. Press the switch ③ to close the moonroof. To stop the moonroof in a midway position while opening or closing, momentarily press the switch to the ④ side or ③ side.

Controls

Light Controls

AUTO: The vehicle's lights are automatically on or off depending on the level of the outside light.

Push up for right turn signal.

Turns on headlights, instrument panel illumination, parking lights, taillights and license plate lights.

Push down for left turn signal.

Turns on fog lights (if equipped).

Turns on instrument panel lights, tail lights, parking lights and license plate lights.



While the light switch is on, rotate the dial downward to dim the instrument panel illumination. Rotate the dial upward to make the illumination brighter. When the dial is fully rotated upward, the instrument panel illumination becomes full bright.



Windshield Wipers

To turn on the wipers, press the wiper control lever down one level for intermittent, two levels for low, or three levels for high speed. Return the lever to the "OFF" position to stop the wipers. For a single wipe, move the lever up. To spray washer fluid, pull and hold the lever toward you.

Daytime Running Lights

Daytime running lights are standard on your vehicle. Only a reduced brightness high beam will be automatically turned on when the engine has started and the parking brake is fully released and the light switch is in the "OFF" or "AUTO" position. The brightness of the illumination of the high beam headlights is reduced by the daytime running light system. You must always switch on your headlights when it's dark outside by turning the light switch to the "OFF" position.

Controls



Manual Climate Control (if equipped)

1. Temperature Control Dial

Rotate the temperature control dial from blue for cool, to red for warm.

2. Air Conditioning Button

Press the "A/C" button to activate the air conditioning. Press it again to turn off the air conditioning.

3. Recirculated / Outside Air Button

Press the air inlet selection button to prevent outside air from being drawn into the passenger compartment. If the button is pushed in, press it again to draw outside air into the compartment. TO PREVENT WINDSHIELD FOGGING, DO NOT REMAIN IN THE RECIRCULATED MODE FOR AN EXTENDED PERIOD OF TIME.

4. Fan Speed Control Dial

Rotate the fan speed control dial to select one of four fan speeds.

5. Rear Window Defogger Button

Press the rear window defogger button to turn on the defogger. The defogger will automatically shut off after about 15 minutes. If the window clears before that time, you can press the button again to turn it off.

6. Defrost / Defog

To clear the windshield and front door windows of fog or frost, press the defrost button, set the temperature control to the red position, and set the fan speed control to the fastest speed.

While in defrost mode, the air inlet selection and A/C will operate automatically (although the A/C indicator will illuminate if the button was depressed prior to or during defrost mode).

7. Air Flow Control Buttons

The air flow control buttons allow you to choose the direction of air flow. Press in the desired button.

Controls



Automatic Climate Control (if equipped)

1. Automatic On and Off

This system automatically controls outlet air temperature, fan speed, air flow distribution, air inlet control, and air conditioner compressor operation. Press "AUTO" to activate. Press "OFF" to turn off the system.

2. Temperature Control Buttons

Press the blue down arrow (cool) or the red up arrow (warm) to select and maintain a comfortable climate within the driver and passenger compartment.

Temperature is displayed digitally on the screen. Separate temperature settings can be adjusted for the driver's side and passenger's side.

Operation in Manual Mode

3. Recirculated / Outside Air Button

Press the air inlet selection button to prevent outside air from being drawn into the passenger compartment. Press the button again to allow outside air into the compartment. TO PREVENT WINDSHIELD FOGGING, DO NOT REMAIN IN THE RECIRCULATED MODE FOR AN EXTENDED PERIOD OF TIME.

4. Fan Speed Control Buttons

Press the fan speed control buttons to select six different fan speed positions.

5. Air Flow Mode Selection Button

Press the button to select the desired air flow mode. The selected air flow mode – either ventilation, bi-level, heat, heat-defrost or defrost – is shown on the display.

6. Dual Mode Button

Press the "DUAL" button to activate or deactivate the dual mode. Dual mode makes it possible to have separate temperature settings for the driver's side and passenger's side.

7. Air Conditioner Button

Press the "A/C" button to activate the air conditioning. Press it again to turn off the air conditioning.

8. Defroster Button

Press the button to defrost or dehumidify the windshield and front door windows.

9. Rear Window Defogger Button

Press the button to turn on the defogger. It will automatically shut off after about 15 minutes. If the window clears before that time, you can press the button again to turn it off.

Controls



HD Radio® with Single Disc CD/MP3/WMA Player (if equipped)

Radio Functions

1. Power / Volume Control

Press the power / volume control knob for on or off; rotate the knob to control the volume.

2. Bass, Middle, Treble, Fader and Balance

Press the “SETTING” knob; rotate the knob to select the preferred menu. Press the knob again to enter the selected menu; rotate the knob to adjust the feature.

3. FM / AM

Press the “FM/AM” button to choose FM1, FM2, FM3 or AM reception.

4. Tune / Track

Rotate the “SCROLL/TUNE” knob clockwise to increase the tuning frequency; rotate the knob counter-clockwise to decrease it.

5. Seek

Press the right or left arrow of the “SEEK” button to pick up the next highest or lowest frequency.

6. Presets

You can save up to six favorite stations for each band – FM1, FM2, FM3 and AM. Select a frequency and press one of the preset buttons until a confirmation beep is heard.

7. Satellite Radio

You can hear satellite radio programs by pressing the “SAT” button. To receive satellite radio service after your trial period, it is necessary to enter into a separate contract with the satellite radio provider.

CD Player functions

8. Load

Insert a disc into the slot. The CD will automatically be drawn in and will begin play at the first track.

9. Play CD

Press the “CD/AUX” button and playback will begin.

10. Repeat / Random

Press the “RPT” button once to repeat the current folder; press twice to repeat the current track.

Press the “RDM” button once to randomize tracks on a CD; press twice to randomize all tracks in a folder.

11. Eject

Press the button to eject the disc.

12. Forward / Reverse

Press the right arrow of the “SEEK” button to skip to the beginning of the next track. Press the left arrow to skip to the beginning of the current track; press again to go to the previous selection.

13. Fast Forward / Fast Reverse

Press and hold the right arrow of the “SEEK” button for more than one second to fast forward. Release the button to stop. To fast reverse, press and hold the left arrow for more than one second and release the button to stop.

14. Scan

Press the “SCAN/A.S” button to begin previewing the first 10 seconds of each track on the disc. Normal playback will resume after all tracks have been scanned. Press the “SCAN/A.S” button again to stop scanning and listen to the track being previewed.

MP3/WMA Formatted CD Player Functions

15. Folder Selection

Rotate the “SCROLL/TUNE” knob clockwise to select the next folder. Rotate the knob counter-clockwise to go to the previous folder.

HD Radio® Functions

16. HD Radio® Selection

Press the “HD/TEXT” button while listening to FM radio (will not work in AM broadcast). The next channel of the station that is being received will play.

You can change the HD Radio® settings by going into the settings menu.

Controls



AM/FM Stereo with Single Disc CD/MP3/WMA Player (if equipped)

Radio Functions

1. Power / Volume Control

Press the power / volume control knob for on or off; rotate the knob to control the volume.

2. Bass, Middle Treble, Fader and Balance

Each press of the “TUNE/TRACK/CH” button will cycle you through Bass, Midrange, Treble, Fade or Balance. Rotate the “TUNE/TRACK/CH” knob to adjust the desired level.

3. FM / AM

Press the “FM” button to choose FM1, FM2 or FM3 reception. Press the “AM” button to choose AM reception.

4. Tune / Track

Rotate the “TUNE/TRACK/CH” knob clockwise to increase the tuning frequency; rotate the knob counter-clockwise to decrease it.

5. Seek

Press the right or left arrow of the “SEEK” button to pick up the next highest or lowest frequency.

6. Presets

You can save up to six favorite stations for each band – FM1, FM2, FM3 and AM. Select a frequency and press one of the preset buttons for more than 1.5 seconds to store it.

7. Satellite Radio

An optional satellite radio tuner and antenna can be connected to this audio unit. You can hear satellite radio programs by pressing the “SAT” button after connecting optional equipment. To receive satellite radio service, it is necessary to enter into a separate contract with a satellite radio provider.

CD Player functions

8. Load

Insert a disc into the slot. The CD will automatically be drawn in and will begin play at the first track.

9. Play CD

Press the “CD/AUX” button and playback will begin.

10. Repeat / Random

Press the “RPT/RDM” button once to repeat the current track; press twice to repeat the current folder.

Press and hold the “RPT/RDM” button once to randomize tracks on a CD.

11. Eject

Press the button to eject the disc.

12. Forward / Reverse

Rotate the “TUNE/TRACK/CH” knob clockwise to skip to the beginning of the next track; rotate the knob counter-clockwise to skip to the beginning of the current track. Rotate the knob counter-clockwise again to go to the previous selection.

13. Fast Forward / Fast Reverse

Press and hold the right arrow of the “SEEK” button for more than one second to fast forward. Release the button to stop. To fast reverse, press and hold the left arrow for more than one second and release the button to stop.

14. Scan

Press the “SCAN” button to begin previewing the first 10 seconds of each track on the disc. Normal playback will resume after all tracks have been scanned. Press the “SCAN” button again to stop scanning and listen to the track being previewed.

MP3/WMA Formatted CD Player Functions

15. Folder Selection

Press the up arrow of the “FOLDER” button to select the next folder. Press the down arrow to go back to the first music file. Quickly press the down arrow again to go back to the previous folder.

16. Page Scroll

Press the “TEXT” button to select title display. Press and hold again to scroll through the title, 8 characters at a time. Up to a maximum of 64 characters.

17. Display

Press and hold the “TEXT” button during playback to change the display to show the play time, disc title, artist name and track title. If the disc is formatted with MP3/WMA, press the “TEXT” button to change the display to show play time, folder name and file name.

Controls

Steering Wheel Audio Controls (if equipped)

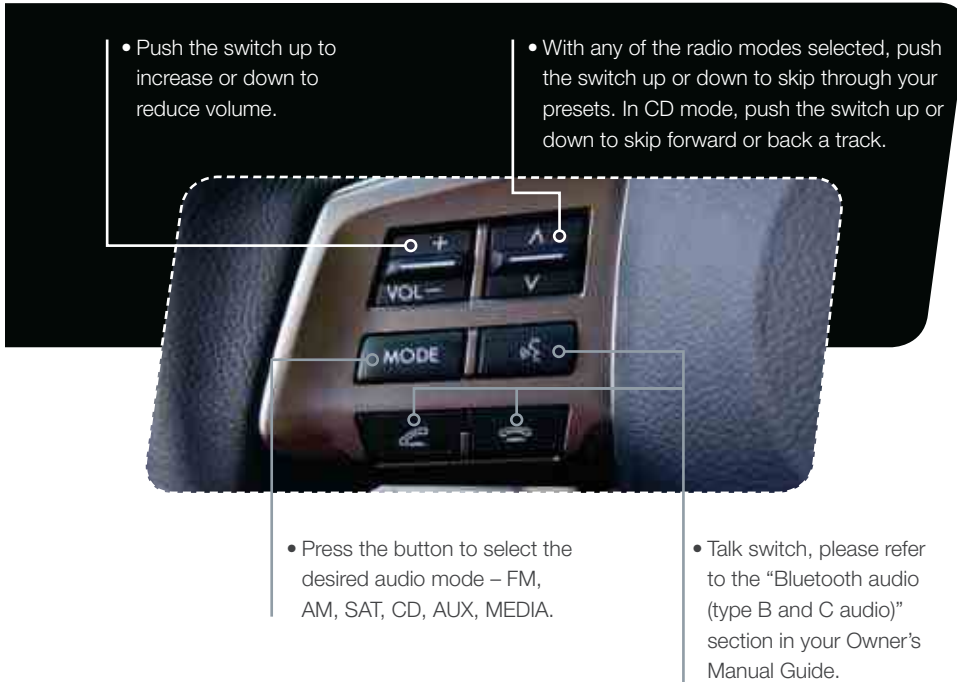

- Push the switch up to increase or down to reduce volume.
- With any of the radio modes selected, push the switch up or down to skip through your presets. In CD mode, push the switch up or down to skip forward or back a track.
- Press the button to select the desired audio mode – FM, AM, SAT, CD, AUX, MEDIA.
- Talk switch, please refer to the “Bluetooth audio (type B and C audio)” section in your Owner’s Manual Guide.

Aux Jack

The aux jack is located in the center console. You can connect a portable music player to the auxiliary jack and hear the music stored on it through the vehicle speakers. Press the “CD/AUX” button located on the audio system to select the auxiliary mode.

USB Storage Device / iPod® (if equipped)

You can connect a USB equipped portable music player to the USB connector and hear the music stored on it through the vehicle speakers. Press the “CD/AUX” button located on the audio system repeatedly until the USB / iPod® mode is selected.

Cruise Control

- To activate the cruise control, press the “CRUISE” button. The “CRUISE” indicator light on the instrument panel will turn on. To deactivate cruise control, press the “CRUISE” button again.
- To resume your speed after canceling, push the switch to the “RES” side.



- To cancel the cruise control, push the brake pedal or press the “CANCEL” button. If you have a manual transmission, you can push in the clutch pedal.
- Press the accelerator pedal until your vehicle reaches the desired speed. Push the switch to the “SET” side and release. Ease off the accelerator pedal. Your vehicle will maintain the desired speed.

Increase speed

Push up the “RES/SET” switch to the “RES” side; hold until your vehicle reaches the desired speed and release. To increase speed using the accelerator pedal, press the pedal until you reach the desired speed. Push down the “RES/SET” switch to the “SET” side to set the speed.

Decrease speed

Push down the “RES/SET” switch to the “SET” side; hold until your vehicle slows to the desired speed and release. To decrease the speed using the brake pedal, press the pedal to release cruise control temporarily. When the speed decreases to the desired speed, push down the “RES/SET” switch to the “SET” side to set the speed.

While Operating



Electronic Parking Brake

To apply, push the brake pedal and press the parking brake switch firmly. The brake system warning light on the instrument panel and the indicator light on the parking brake switch will illuminate.

To release, make sure all doors are closed and your seatbelt is fastened, then gently push the accelerator pedal. Or, while the ignition switch is in the ON position and the brake pedal and the clutch pedal (MT models only) are pushed in, pull the parking brake switch toward you.



Hill Holder™ Function

When the Hill Holder function is activated, the parking brake will be automatically applied when stopped on an uphill or downhill slope with the brake pedal pushed down. The brake system warning light and the indicator light on the parking brake switch will illuminate. To activate, press the Hill Holder switch. To deactivate, press the Hill Holder switch again.

Automatic Transmission Shift Mode

The 5-Speed automatic transmission or the Continuously Variable Transmission (CVT) gives you ultimate control with two different driving modes: Normal Mode and Manual Mode.

Normal Mode

When the selector lever is in the “D” (Drive) position, the transmission is in Normal shift mode. The shift position indicator on the instrument panel shows “D” and the transmission automatically shifts into a suitable forward gear.

Manual Mode

In Manual Mode, you select the desired gear position to obtain necessary acceleration

and engine braking. Moving the selector lever left into the manual gate ① from “D” (Drive) position causes the transmission to change into Manual Mode. To shift, use the paddle shift control switches. The shift position indicator shows the selected gear position.

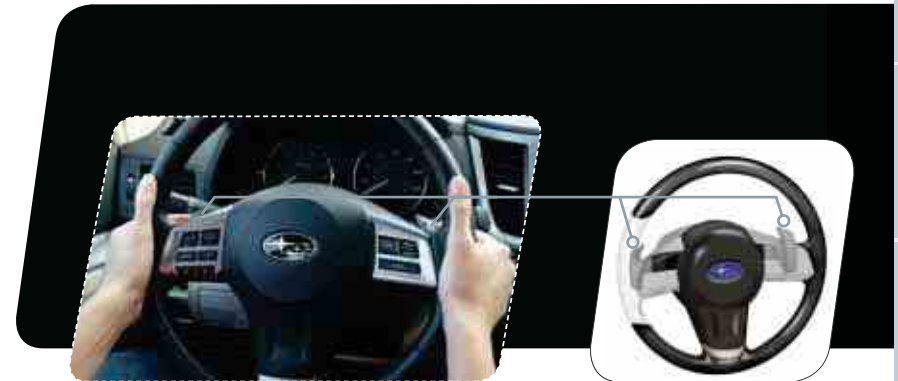

Paddle Shift Control Switches

- Temporary use: Even when the selector is in the “D” (Drive) position, you can temporarily shift the gear by pulling the “+” or “-” paddle shift control switch. The transmission will automatically switch back to Normal Mode.
- When the selector lever is in Manual Mode, shift to the next higher gear by pulling the “+” paddle shift control switch on the steering wheel. Pull the “-” paddle shift control switch to shift into the next lower gear.

When Manual Shifting Operation Is Possible

- Arrow-shaped lights in the center of the instrument panel show whether an upshift is possible and whether a downshift is possible.
- Both arrows are on: Upshifting and downshifting are both possible.
- Up arrow only is on: Only upshifting is possible.
- Down arrow only is on: Only downshifting is possible.

Safety / In Case of Emergency

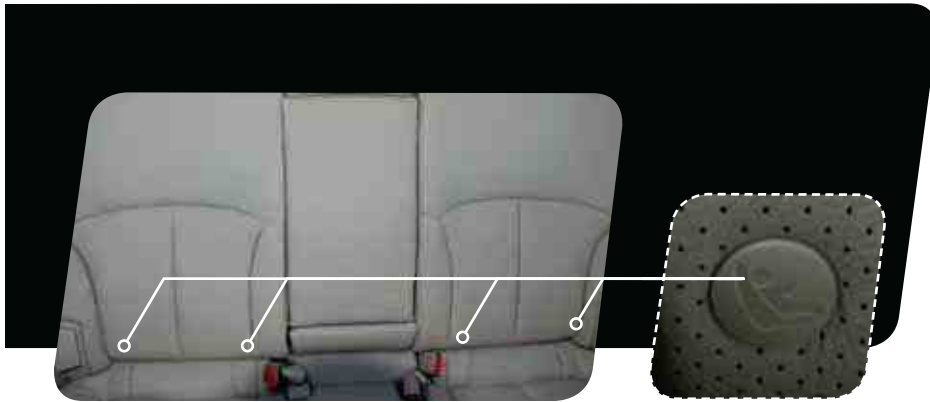

Child Restraint System

For maximum safety, first carefully read the LATCH system instructions from the device manufacturer, as well as the installation instructions in your Owner's Manual, to properly install the LATCH compatible restraint system. Use the appropriate seatbelts or anchorages provided in your vehicle. Children age 12 and under must properly occupy the rear seat at all times.

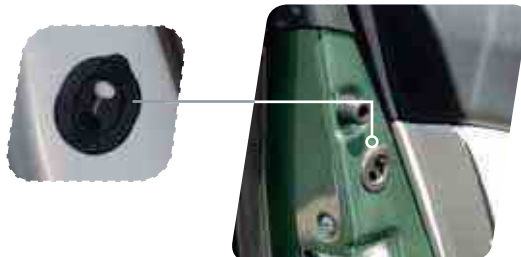

Child Safety Locks

The child safety locks are located on the inside edges of the rear doors. In the locked position, the rear doors can only be opened from the outside.



Trunk Lid Opener Switch (inside glovebox)

With the trunk lid opener switch on, the trunk lid cannot be opened with the trunk lid release or with the key.

To lock the trunk lid opener switch, press the trunk lid opener lock button. To unlock the trunk lid opener switch, press the switch again.



Internal Child Safety Trunk Release with Self-Illuminating Handle

In the event that children or adults become locked inside the trunk, this luminescent handle allows them to open the lid from inside the trunk. To open, simply pull the yellow handle downward as indicated by the arrow on the handle, and then push up on the lid.



Location of Spare Tire and Jack

A jack and other maintenance tools are stored in the tool bucket in the center of the spare tire, located in the trunk or cargo area. Raise the center lid and remove the bucket from the center of the spare tire. Take the jack out of the bucket. The jack handle is stowed on the back of the floor cover of the trunk.

Towing Your All-Wheel Drive Vehicle

Since all-wheel drive distributes engine power to all four wheels, improper towing will severely damage your AWD system. A flatbed truck is the only recommended way to properly transport your AWD vehicle. If towing is necessary, it is best done by your Subaru dealer or a commercial towing service.

Subaru Roadside Assistance

Subaru Roadside Assistance is free and standard on every 2011 Subaru vehicle. Coverage is automatic; there are no forms to complete. Subaru Roadside Assistance is available anytime during the 3-year/36,000-mile Subaru Limited Warranty, whichever comes first.* A Subaru Roadside Assistance decal has been affixed to the driver's door window.

Subaru Roadside Assistance: 1-800-261-2155

Exclusions

Specifically excluded from Subaru Roadside Assistance coverage are service requests or claims resulting from: accidents, vandalism, acts of God, violation of any laws, or vehicle modifications not recommended by the manufacturer.

*See your dealer for details

Additional Information



MY.SUBARU.COM

Your Subaru vehicle comes with a unique online resource that helps make your ownership experience more convenient and enjoyable. My.Subaru.com is a website that you can personalize and offers useful features and content that makes it easy for you to manage your vehicle care and enjoy all the benefits of Subaru ownership. Log on to My.Subaru.com to access features such as: automated service history, e-mail maintenance reminders, online Owner's Manual, warranty information, maintenance schedules and much more...

Access your site today @ My.Subaru.com

Fuel

Non-turbo models

Use regular unleaded gasoline with an octane rating of 87 AKI or higher.

Turbocharged and Intercooled models

Use only premium unleaded gasoline with an octane rating of 91 AKI or higher.

Fuel Capacity

- 18.5 US gal (70 liters, 15.4 Imp gal)
- When the low fuel indicator light is displayed on the instrument panel, approximately 2.6 U.S. gallons of fuel remain.
- If you have recently fueled your vehicle, the check engine light on the instrument panel may stay on due to a missing or loose fuel filler cap (the cap should be tightened until a click is heard).

Engine Oil

Use only the following oils:

- API classification SM or SN with the words "ENERGY CONSERVING" or "RESOURCE CONSERVING".
- Or ILSAC GF-4 or GF-5, which can be identified with the ILSAC certification mark (Starburst mark).

Engine Oil Capacity

- 2.5 L non-turbo models: 4.4 US qt (4.2 liters, 3.7 Imp qt)
- 2.5 L turbo models: 4.5 US qt (4.3 liters, 3.8 Imp qt)
- 3.6 L models: 6.9 US qt (6.5 liters, 5.7 Imp qt)

Subaru Delivery Checklist

Owner Information

VEHICLE ID #	<input type="text"/>
DELIVERY DATE	<input type="text"/>
OWNER NAME	<input type="text"/>
OWNER NAME	<input type="text"/>

Owner Resources & Warranty

- q Present the Subaru Owner's Manual & Quick Reference Guide (detailed review in "Operation & Controls" section)
- q Review Subaru Roadside Assistance, Owner Cards & Provide Toll-Free Number 1-800-261-2155
- q Explain 3/36 BASIC Warranty / 5/60 Powertrain Warranty / Explain Wear Items & Adjustments / PZEV (if applicable) / Review Rust Perforation Warranty / Tire Warranty
- q Review Service & Maintenance Schedules & Terms Explain Normal vs. Extreme Schedules (if applicable)
- q Review New Owner's MY.SUBARU.COM Website
- q Review The Subaru Mastercard Program from CHASE & Explain The Card Benefits
- q Explain Dealership's New Owner Follow Up Procedure

Customer Signature

- q Review Dealership Service Department Location, Payment Options & Hours of Operation
- q Introduce The Subaru Service Advisor & Provide Their Business Card
- q Explain Dealership Service Appointment Scheduling & Early Morning Service Drop Off Procedures
- q Review Dealership Parts Department Location & Hours

Vehicle Condition

- q Exterior Condition Approval (New Owner indicated exterior of vehicle is clean & undamaged)
- q Interior Condition Approval (New Owner indicates interior of vehicle is clean & undamaged)
- q Operational Condition Approval (New Owner has driven vehicle & approves it is ready for delivery)

NEW OWNER SIGNATURE
SALES CONSULTANT SIGNATURE
SALES MANAGER SIGNATURE

Fold back and remove this checklist from the ORG. Place this completed checklist in the deal jacket for future reference. Additional copies of this checklist can be made by photocopying.

Operation & Controls

Please use & reference the **SUBARU OWNER'S MANUAL** & **QUICK REFERENCE GUIDE**

OPERATION & CONTROLS

- q Review Master & Valet Keys
- q Review Yellow Caps & Explain Checking & Filling of Vehicle Fluids
- q Show Keyless Entry, Alarm System & Remote Start (if equipped)
- q Show Fuel Filler Door & Gas Cap Operation
- q Show Hood & Gas Door Releases
- q Show Location of Both Fuse Boxes

REAR & SIDE

- q Show Trunk Release & Valet Feature (sedans only)
- q Explain AWD Towing Requirements & Limitations
- q Show Spare Tire, Tools & Jack Location
- q Show LATCH System & Tethers
- q Explain Temporary Spare Tire Usage & Limitations
- q Show Child Safety Lock Operation

INTERIOR

- q Explain Operation of Manual Transmission & Incline Start Assist (if equipped)
- q Show Seatbelt & Head Restraint Functions
- q Explain Operation of Automatic Transmission & Review Manual Mode (if equipped)
- q Show Tilt Steering Column & Telescopic Feature (if equipped)
- q Show All Weather Package - Heated Front Seats, Windshield Wiper De-Icer & Heated Side Mirrors (if equipped)
- q Explain the Subaru Advanced Frontal Airbag System (SRS), Front Seat Side Pelvis/Torso Airbags (SRS) & Side-Curtain Airbags (SRS)

DRIVER CONTROLS & OPERATION

- q Show Power Windows, Door Locks & Side-View Mirror Operation
- q Review Instrument Panel Gauges & Warning Lights
- q Explain Cruise Control & Power Moonroof Operation (if equipped)
- q Explain Tire Pressure Monitoring System Light
- q Show Auto Headlights, Daytime Running Lights, Parking Lights, Hazard Lights & Fog Lights (if equipped)
- q Show Audio System, Station Presets, Tone, Balance & Fade Controls
- q Show Interior Lighting, Map Light & Clock
- q Show GPS Navigation System (if equipped)
- q Show Front & Rear Wiper & Washer Controls
- q Show Climate Control System Including Front & Rear Defrosters
- q Show & Explain Operation of VDC Control Switch
- q Explain Operation of Other Vehicle Options, Equipment, or Genuine Subaru Accessories Not Referenced Above Where Applicable

2012

**Consumer Electronics/
Bluetooth® & Audio Technology**



Quick Reference Guide





Table of Contents

Bluetooth Basics	2 - 3
Bluetooth without Navigation System	
Impreza 2.0i / WRX / WRX/STI / Forester 2.5X	4 - 7
Legacy and Outback	8 - 11
BlueConnect®	
Tribeca	12 - 13
Bluetooth with Navigation System	
Impreza 2.0i / WRX / WRX/STI / Forester 2.5X	14 - 17
Legacy and Outback	18 - 21
Bluetooth with TomTom® Navigation	
Select Forester 2.5X Premium	22 - 23

Bluetooth Basics

- The Hands-free system may not operate properly under the following conditions:
 - o The cell phone is turned off.
 - o The cell phone is not connected to the Hands-free system.
 - o The cell phone is not in the phone call area.
 - o The battery of the cell phone has run down.
 - o The cell phone is behind the seat or in the glove box.
 - o A metal material covers or touches the cell phone.
- Depending on the type of cell phone that is used, the screen on the cell phone may remain illuminated while the ignition switch is in the "ON" position. If this occurs, consult your cell phone manual to adjust the cell phone settings.
- Depending on the setting of the cell phone, the dial lock function may be activated after making a call. Deactivate the automatic dial lock function of the cell phone before using the Hands-free system. Do not perform this operation while driving.
- Depending on the type of cell phone that is used, operation and the sound volume may vary.
- Depending on the type of cell phone that is used, not all phone functions may be compatible with your vehicle.
- When the ignition switch is turned to the "LOCK/OFF" position during a call, the call may be disconnected or continued on the cell phone depending on the type of cell phone that is used. Note that operation of the cell phone may be necessary if the call is continued on the cell phone.

- Do not speak at the same time as the other party during a call. If you and the other party speak at the same time, it may be difficult for the other party to hear your voice and vice versa. This is normal.
- The receiver sound volume should be set as low as possible. Otherwise, the party you are calling may notice an undesirable echo sound.
- Speak clearly and loudly.
- Your voice may be difficult to be heard by the receiving party under the following conditions:
 - Driving on a rough road.
 - Driving at a high speed.
 - Driving with a window open.
 - When air from the ventilator blows directly towards the microphone.
 - When the sound coming from the ventilator is loud.
 - When the cell phone is positioned too closely to the microphone.
- The sound quality may degrade due to the influence of the cell phone that is connected to the system or the circumstances of the Bluetooth network.
- When another Bluetooth device is simultaneously connected, noise may be heard in the voice coming from the hands-free phone.

Bluetooth for AM/FM Stereo and Single Disc CD Player (Impreza 2.0i/WRX/WRX STI, Forester 2.5X)



Pairing Your Cell Phone

Press the phone off hook button and listen to phone prompts.



Press the talk button and name your phone.



Press the talk button and say “confirm.”



Pass-key for pairing will be given audibly as well as be displayed on the radio display.



Put your phone into Bluetooth pairing mode and pair your phone to the system using the pass-key provided. When phone is successfully paired you will hear “The phone is paired and ready for use.”



Making a Call

Press phone off hook button. Press the talk button then say "Dial by number."



Press the talk button again and say the number.



Press the phone off hook button to dial or press the talk button to add more numbers. The phone will start dialing.



To end the call, press the phone on hook button.

Receiving a Call

When a call comes in you will be notified. If the audio system is on, the audio system will mute and a voice prompt will inform you. Press the phone off hook button to accept the call.



- If you want to put the call on hold, press the phone on hook button.
- If you want to decline the incoming call, press and hold the phone on hook button.
- If you want to adjust the volume of the call, use the plus or minus switch on the steering wheel.

Bluetooth for AM/FM Stereo with Display Type Radio (Legacy and Outback)



Phone off
hook button

Phone on
hook button

Talk button

Pairing Your Cell Phone

Press the phone off hook button.



Rotate the tune knob, to select "Pair Phone".



Follow the audible prompt, then select "Record Name" and then say the name to be registered.



Select "Confirm pair phone?".



Select "Device Type".



Select "Phone Only" to register a cell phone.



After "Car Multi-Media" is displayed, a pass key to pair phone will be displayed.



Input the displayed passkey into the cell phone while "Passkey: ****" is displayed.



"Phone paired successfully" will be displayed when pairing has been completed.



Making a Call

Press the talk button then say "Dial by number."



Press the talk button again and say the number.



The system will audibly repeat the number. If correct, press the phone off hook button to dial, or press the talk button to change, cancel or delete the number. The phone will start dialing.



To end the call, press the phone on hook button.

Receiving a Call

When a call comes in you will be notified. If the audio system is on, the audio system will mute and a voice prompt will inform you. Press the phone off hook button to accept the call.



- If you want to put the call on hold (only if your cell phone has this function), press the phone on hook button.
- If you want to decline the incoming call (only if your cell phone has this function), press and hold the phone on hook button.
- If you want to adjust the volume of the call, use the plus or minus switch on the steering wheel. If you want to end the call, press the phone on hook button.

BlueConnect®

(Tribeca 3.6R Limited and Touring models)

Controls Location

BlueConnect controls for the Tribeca are located in the overhead console.



Controls Function

Phone button – activate and deactivate system.



Volume up and down buttons.

Voice recognition button – Barge in button, to barge in so you don't have to listen to all the prompts.

Pairing Your Cell Phone

- Press the phone button, the blue L.E.D. will glow and “Call” will be displayed. Listen to all options.
- Say “setup”; then listen to all options.
- Say “pairing options”; then listen to all options.
- Say “pair”; listen to the safety message.
- Say “continue.”
- Say your personal four-digit pairing code, for example, “1234.”
- Say “yes” to confirm the key.
- Put your phone into Bluetooth pairing mode and pair your phone to the system using the pairing code you provided earlier.
- Say the name of the device.
- The system will let you know it is adding your phone to the system and it will repeat the name of the device and ask you if it is correct; say “yes.”
- When phone is successfully paired you will hear “Pairing complete.”

Making a Call

- Press the phone button and listen to the prompts.
- Say “dial”; the system will ask for the number.
- Say the number you wish to call (do not pause during the area code, phone exchange and the number).
- The system will repeat the number and ask you if it is correct; if correct say “yes.”
- The system will then dial.

Receiving a Call

- When a call comes in you will be notified. The audio system will mute and a voice prompt will inform you.
- Press the phone button to receive the call.
- To end the call press the phone button again.

Bluetooth for AM/FM Stereo with HD Radio™, Single Disc CD Player and Navigation (Impreza 2.0i/WRX/WRX STI, Forester 2.5X)



AUDIO button

Pairing Your Cell Phone

Press the AUDIO button; then touch the “Info” soft key on the touch screen.



Then touch “Bluetooth.”



Now touch "Registered Devices."



Touch "Add New."

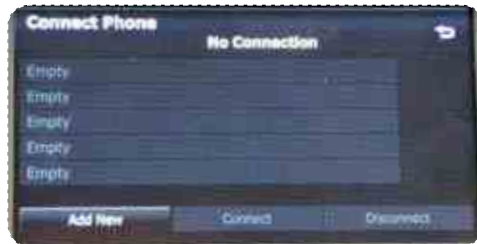

A pass-key pairing number will appear on the screen. Put your phone into Bluetooth pairing mode and pair your phone to the system using the pass-key provided.



When the phone is successfully paired the screen will show the phone's name on the list.



Making a Call

Press the AUDIO button; then touch the "Phone" soft key. A numeric keypad will be displayed.



Touch the numbers for the phone number you wish to call. When complete, touch the green phone soft key to make the call.



During a Call



Red phone symbol – Touch this to end a call.

Dial Tone – Touch to enable numeric key input.

Mic Level – Touch to change the volume of the call.

Transfer – Touch to switch the phone conversation back to your cell phone.

Receiving a Call



Touch "Disconnect" to decline the incoming call.

When a call comes in the incoming call screen appears automatically. Touch the green phone soft key to answer the call.

Bluetooth with Navigation System (Legacy and Outback)



MENU button



Phone off
hook button

Phone on
hook button

Talk button

Pairing Your Cell Phone

Press the MENU button; then touch the "Phone" soft key on the touch screen.



Then touch "Bluetooth Settings."



Now touch "Register."



A pass-key number will appear on the screen.



Put your phone into Bluetooth pairing mode and pair your phone to the system using the pass-key provided. When the phone is successfully paired the screen will show the phone's name on the list.



Making a Call

Press the Talk button on the steering wheel; then say "Dial by number." A numerical keypad will be displayed.



After the beep, say the numbers of the phone number you wish to call. The system will repeat the numbers you have said at this point. You can continue saying numbers, you can cancel, make a correction or dial. Say "Dial"; the system will then dial the number.



During a Call



Mute – Touch this to mute the call.

Speaker – Touch to switch the phone conversation back to your cell phone.

Red phone symbol – Touch this to end a call.

1 – 5 – Touch 1 through 5 to change the volume of the call.

Receiving a Call



Touch "Hold" to put the call on hold.

Touch "Disconnect" to decline the incoming call.

When a call comes in you will be notified. The audio system will mute and a voice prompt will inform you. Touch the "Call" soft key to answer the call.

TomTom® Navigation with Bluetooth (Optional on Forester 2.5X Premium models)



Pairing Your Cell Phone

- Tap anywhere within the displayed navigation map to bring up the Main Menu.
- Tap Mobile Phone in the Main Menu.
- Tap Phone Preferences in the next screen.
- Tap Bluetooth Preferences in the next screen.
- Tap Connect to Bluetooth device in the next screen. At this point, make sure that:
 - The Bluetooth is turned “on” on your phone, and the phone is set to discoverable.
 - If a password is asked by your phone, use 0000.
 - Check your phone user guide for specific information about Bluetooth settings.

Making a Call

- Tap anywhere within the displayed navigation map to bring up the Main Menu.
- Tap Mobile Phone in the Main Menu.
- Tap Call in the next screen. (If more than one phone is paired, make sure that your phone is currently selected. Current phone is shown at the bottom of the screen).
- Tap number to enter a phone number to call in the next screen, and press the green phone to send, or do one of the following:
 - Tap Home to call your previously entered phone number.
 - Tap Point of Interest to choose a POI call.
 - Tap Phonebook Entry to select a contact from your phonebook (must be previously imported from your phone).
 - Tap Recently Dialed to select from a list of people or numbers recently called using your phone.
 - Tap Recent Caller to select from a list of people or numbers who called you recently.



Receiving a Call

If someone calls when you are driving, a screen will automatically pop up, and you will have the option to Accept or Refuse the call. If you accept the call, the radio should mute, and the call will be connected. (If the radio does not mute, tap the Mute button on the radio to silence the radio).



All information contained within this Consumer Electronics/Bluetooth & Audio Technology Quick Reference Guide was accurate at the time of publication. We reserve the right to change features, operation and/or functionality of any vehicle specification at any time without incurring any obligation to make the same or similar changes to products previously sold. Your Subaru dealer is the best source for the most current information. For detailed operating and safety information, please consult your Owner's Manual.



MSA5B1109A
Printed in USA 01/12

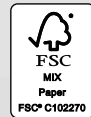



REAR SEAT ENTERTAINMENT SYSTEM USER GUIDE



The specifications, constructional data and illustrations contained in this publication are not binding. We reserve the right to make alterations without prior notification.

General information	3
Before using the system	3
System overview	4
Kit contents	4
Main features	4
Technical specifications	5
Quick guide	6
Playing a DVD movie	6
Using the wireless headphones	6
Playing audio/video via game port inputs	6
Buttons on the front panel	7
Controls and connectors	7
Remote control	9
Buttons and functions	9
DISPLAY	11
Using the display	11
Settings for display screen	11
DISPLAY MENU	12
Audio control menu	13
Language menu	13

DVD player	14
Use the DVD player.....	14
Settings for the DVD player.....	14
General Setup	15
Audio Setup	16
Preference	17
Password Setup	18
Handling DVDs	19
Tip	19
Icon display	20
Meaning of the icons	20
Troubleshooting	21
Troubleshooting	21
Default Settings	24
Default Settings	24

Before using the system

Note!

- Read through this user manual carefully before using the device.
- Save the user manual for future reference.
- Follow the instructions in the manual carefully when using the device.
- Never use the entertainment system in a way that interferes with driving.

Caution!

- Damage caused by unauthorized repairs or upgrades may void your warranty.
- Do not use chemical solutions, cleaning agents or corrosive agents to remove dirt from the display screen. This can cause permanent damage to the screen surface. We recommend using a soft damp lens cleaning cloth to remove dirt or nger prints.
- Do not touch or push the display screen when using the device.
- Excess force can cause permanent damage to the display screen.
- Lock the display screen in the closed position when not in use.
- Do not use DVD or CD disks with adhesive labels. These labels can come off inside the unit and cause damage.
- Do not recline/move the front seat so that it collides with the roof of the car.
- Do not recline/move the front seat so that it collides with child seats.

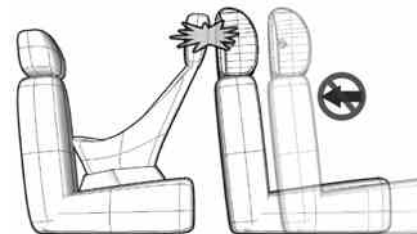

System overview

Kit contents

- 2 head restraints with screens including DVD player
- 1 remote control
- 2 two-channel wireless IR headsets
- 6 x AAA batteries (4 for headsets and 2 for the remote control)
- 2 adapter cables for the audio/video input
- 2 x 3.5 mm extension cables

Optional accessories

- Additional dual channel wireless IR Headphones (Part Number H001SAJ330)

Main features

- 7" TFT-LCD-screen with head restraint
- Built-in DVD player with support for DVD, VCD, AUDIO CD-R/RW and MP3 CD.
- Built-in Wireless Headphone IR Transmitter
- 1 Audio/Video Input in each headrest
- Full function wireless remote control
- OSD (On Screen Display). Graphic menu used to adjust picture quality, image, and clarity.
- Integrated with the vehicle's audio system. Audio can be output through the vehicle's speakers.
- Primary function controls integrated to front bezel.

Technical specifications

Display	7.0" widescreen, TFT LED active matrix
Resolution	800 (W) x 480 (H) x 3 (R.G.B.)
Dot pitch	0.0635 (W) x 0.1905 (H) mm
Viewing angle	50°/70°/70°/70° (from above/below/left/right)
Brightness	450 cd/m ²
Contrast ratio	500:1
Power	12V DC (negative ground)
Power consumption	Active (DVD being played): approx. 20W Max (start-up and insertion of disc): approx. 32W
Panel dimensions	165 x 5.5 x 104 mm (W x D x H)
Built-in temperature control system	<p>If temperature is greater than +175°F (+80°C), system will power down.</p> <div style="border: 1px solid black; padding: 5px;"> <p>i Note!</p> <p>Temperature control system monitors the temperature of the circuit board inside the device and not the ambient temperature outside in the passenger compartment.</p> </div>

Quick guide

Playing a DVD movie

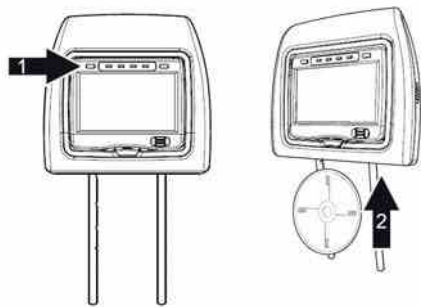

- Activate the entertainment system by pressing the switch (1) on the front panel and inserting a DVD (2).

Using the wireless headphones

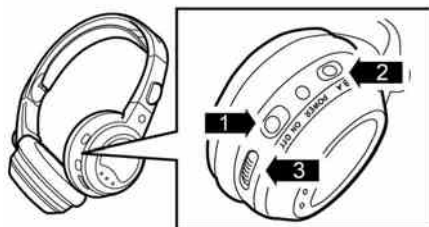

- Activate the wireless headsets with the power switch (1).
- Select CH A if sitting behind the right seat or CH B if sitting behind the left seat (2).
- Adjust the volume (3).

Battery Replacement

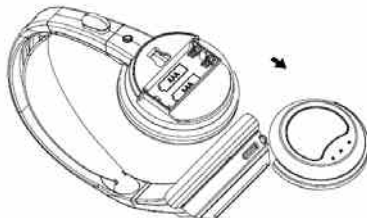

Playing audio/video via game port inputs

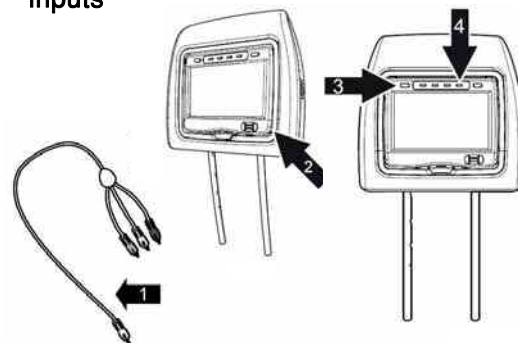

- Connect the device you want to use via the mini-jack/TRCA wiring (1).
- Insert the mini-jack cable into the port underneath the front panel (2).
- Activate the entertainment system by pressing the power switch (3) on the front panel.
- Then press the **S** button for signal source (4) on the front panel until "AUX-AUDIO/VIDEO INPUT" appears at the top left corner of the screen.

Buttons on the front panel

Controls and connectors

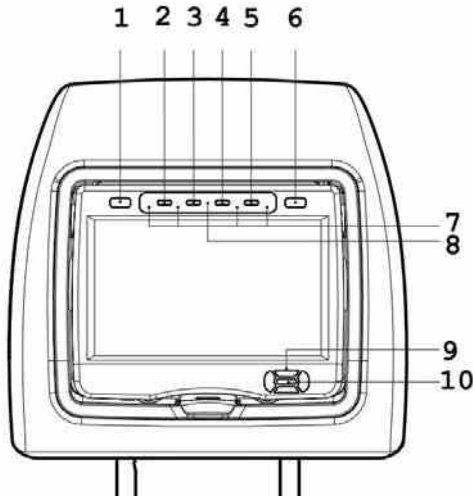

1 **POWER CONTROL**

Switches the screen on/off.

2 **Title**

Press to return to the DVD root menu.

3 **Play/Pause**

Play/pause playback of the disc.

4 **STOP**

Stops disc playback.

- Press the **Stop** button twice and then **Play** to play the disc from the beginning.
- Press the **Stop** button and then **Play** to resume playing from the last stopped place.

5 **Signal source**

Switches between signal sources DVD, LEFT INPUT/RIGHT INPUT and AUX AUDIO/VIDEO INPUT. If LEFT INPUT/RIGHT INPUT is selected as signal source for one screen, the screen menus, display and audio will be controlled by the other screen and remote control.

6 **Menu**

Opens the main menu.

7 **IR transmitter**

Transfers audio to the wireless headsets.

8 **IR sensor**

Receives infrared signals from the remote control.

9 **Navigation buttons**

Press to navigate Rewind/Fast-forward/Next/Previous tracks and make selections in DVD title menus. In DVD or screen menus they are used to adjust and select options.

10 **OK button**

Press to confirm menu options

EN Rear Seat Entertainment system

Buttons on the front panel

11 Headset socket

3.5 mm standard socket for headsets.

12 Eject

When the power is on, eject the disc by pressing the eject button next to the DVD slot.

13 A/V input

3.5 mm audio/video input jack. Use with supplied adapter cable.

14 DVD slot

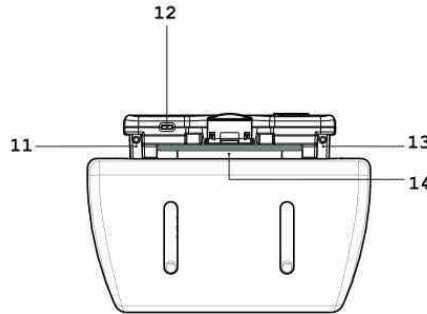

Buttons and functions

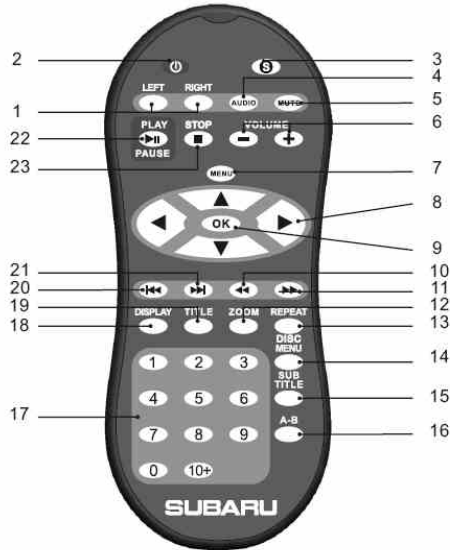

1 LEFT/RIGHT

Press to select and control the screen on the left or right side.

2 POWER CONTROL

Press to power the selected screen on or off.

3 Signal source

Switch between the different signal sources (DVD, LEFT INPUT/RIGHT INPUT and AUX AUDIO/VIDEO INPUT) for the selected screen by pressing the **S** button several times.

4 AUDIO

Hold for 1 sec. to enable/disable RSE audio output to the vehicle's audio system.

5 MUTE

Press once to mute the audio. Press again to restore the audio at the previous volume level.

6 VOLUME +/-

Increases or reduces the audio level.

7 MENU

Opens the main menu.
Activates the DVD player's menu.

8 Navigation buttons

Moves the option or cursor to the left/right/up/down.

9 OK

Press to confirm selection.

10 Back

Search backwards.

11 Forward

Search forward.

12 ZOOM

Zooms in or out of the image. Use the navigation buttons to pan in the zoomed image.

13 REPEAT

Repeat playback of different parts of a DVD, CD or MP3 (track/chapter/option).

14 DISC MENU

Switches between available subtexts during playback of VCD 2.0. Path to DVD title option menu.

15 SUBTITLE

Switches between the subtext languages if applicable.

EN Rear Seat Entertainment system

Remote control

16 A-B

Gives the option to repeat playback of a DVD or CD from point A to point B. Set point A by pressing once, press again to set point B. Press again to clear set points.

17 Number buttons

Direct access to CD track, DVD chapter and used when setting password.

18 DISPLAY

Shows current media information.

19 TITLE

On certain DVDs it is possible to select title. Select desired title with this button.

20 Previous track

Return to previous chapter or track.

21 Next track

Goes to next chapter or track.

22 Play/Pause

Starts playback or starts a function. Pauses playback when button is pressed again.

23 STOP

Stops playback.

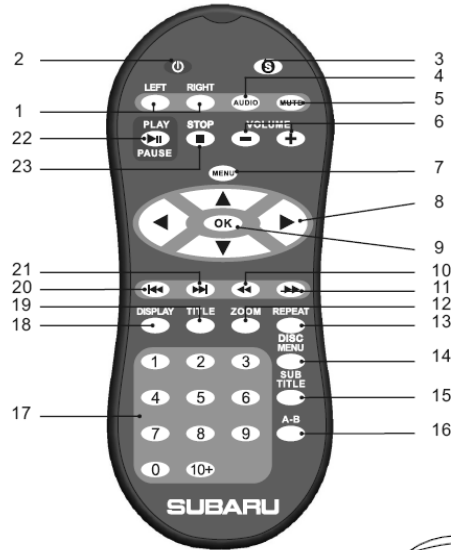

Battery Replacement

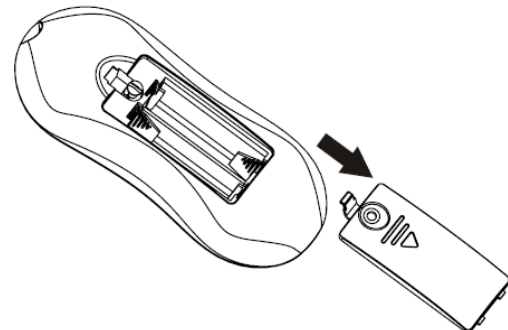

Using the display

- 1 It is possible to set the display to a comfortable viewing angle to prevent glare or bright light by tilting the screen.
- 2 Press the power button on the front panel or on the remote control to turn the display screen on.

i Note!

If the backlight flashes three times and then goes out and the device does not start, the vehicle's battery voltage is too low.

- 3 Press the **S** button to select signal source. Choose one of the following options:
 - **DVD** uses the device's DVD player
 - **LEFT INPUT/RIGHT INPUT** uses the corresponding device's DVD player or AUX AUDIO/VIDEO INPUT.
If there is no signal from the corresponding DVD player, "NO DISC" appears.

- **AUX AUDIO/VIDEO INPUT** uses the connected AUX input.

Settings for display screen



To change display screen settings, open the main menu by pressing the **MENU** button on the remote control or the **MENU** button on the front panel.

Settings for brightness, contrast, color and audio etc are made in the DISPLAY MENU.

DISPLAY

Change settings

Press the navigation buttons on either the remote control or front panel to select the setting you want to change. Use the left/right button to reduce or increase the value for the selected option. If you do not press a button within 7 seconds, the display screen returns to the normal display mode.

DISPLAY MENU



BRIGHTNESS

Adjusts the strength of the background lighting.

CONTRAST

Adjusts the contrast.

COLOR

Adjusts the balance between blue, yellow and red.

TINT

Adjusts the intensity of blue, yellow and red.

DIMMER MODE

Select between Dark mode/Normal mode/ Bright mode

DISPLAY MODE

Select FULL SCREEN or 4 : 3 aspect ratio

WIRE VOLUME

Regulates the volume in the wired headsets.

IR POWER CONTROL

Switches the IR transmitter on and off for the wireless headsets.

AUDIO (A.I.I.) CONTROL

This setting allows you to decide which DVD player's audio will be output to the vehicle's audio system. When both display screens are switched on, the default setting is "ON" on the Right side and "OFF" on the Left side.

If one of the monitor is changed to "ON", the audio from this monitor is output to the vehicle's audio system and the other monitor automatically switches to "OFF".

When a device is plugged into the vehicle's AUX input jack in the center console, the



icon appears on the RSE screen and the Aii output is disabled. When the device is unplugged, the



If MUTE (AUDIO OFF) is activated,



appears on-screen.

LANGUAGE

Select preferred language for display menus. English, French, and German are available.

RESET TO FACTORY SETTINGS

Resets the display screen to factory settings.

DVD player

Using the DVD player.



Note!

Read this entire chapter before using the DVD player.

The DVD player can play DVD, VCD, audio CD-R/RW and MP3 CD.

Regional coding

Both the DVD player and DVD disc are coded by region. These regional codes must match in order for the disc to play. If the codes do not match, the disc will not play. To change the regional code, please consult your Subaru retailer.

To play a DVD or VCD

- 1 Press the **S** button until "DVD" appears.
- 2 Insert DVD or VCD disc (Label Up), the disc will automatically load.
- 3 Press the **PLAY** button to start playback of the selected title.



Note!

"INCORRECT REGION" appears on-screen if the disc's region code is not correct.

- 4 Press the **Pause** button to pause playback, press once to continue playback.
- 5 Press the **Stop** button to stop playback.

Settings for the DVD player

To change the settings on the DVD player, press the **MENU** button on the remote control or the **MENU** button on the front panel to open the main menu, and then select sub menu "DVD SETUP".

In the DVD menu you can make basic settings, adjust the image quality and select different outputs. It is also possible to select language for the text on-screen and the settings menu and restrict playback for children.

The icons on the top row symbolize the pages on which settings for the DVD player can be made:

- General Setup Page
- Audio Setup Page
- Preference Page
- Password Setup Page

Change settings

Select the page you want by moving the cursor using the navigation buttons. Press **OK** to confirm the choice.

Press left button repeatedly as necessary to select different settings page.

Exit settings and menu by pressing the **MENU** button again.

General Setup Page

TV display

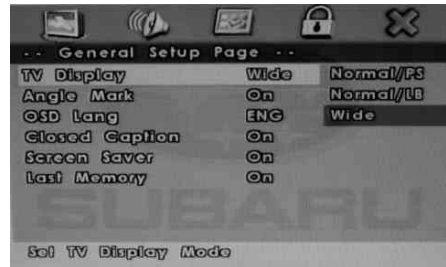

— Select display settings from the following options:

- **Normal/PS** (Pan and Scan)
This displays the wide picture on the screen with a portion of the left & right sides removed.
- **Normal/LB** (Letter-Box)
This display the wide picture with black bands on the upper and lower portions of the screen.

- **Wide** (16:9)

Widescreen in 16:9 format is shown here. This is a recommended setting.

— Confirm the choice by pressing **OK**.

Angle Mark

When the Angle Mark function is selected, an icon appears indicating whether a DVD has double tracks (e.g. commentary track). Press **OK** to select this track.

DVD player

Language for the DVD menu (OSD Lang)

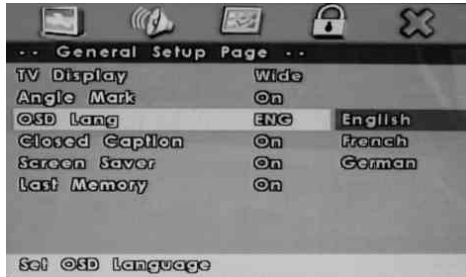

- Select the language for this menu under **OSD Lang**. Available languages are English, French and German.
- Confirm the choice by pressing **OK**.

Closed Caption

Special function for the hearing impaired where certain audio effects are described with text when Closed Caption is selected.

Screen Saver

A screen saver appears when the device is on but no functions are used for 3 minutes.

Press any button to return to the previous image.

LAST MEMORY

If this function is selected, the DVD that is playing when the unit is powered off will resume playback from the same point when power is restored.

Audio Setup Page



- Select loudspeaker and audio settings.

Preference Page

Note!

The menu options Disc Menu, Audio, and Subtitle are not available in this system. Preference page cannot be accessed when a disc is loaded.

TV standard (TV type)

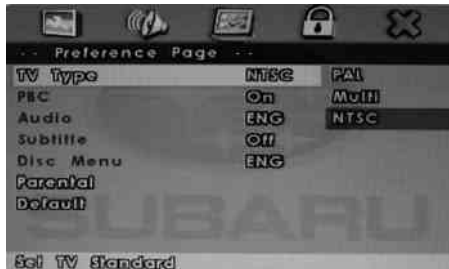

- Select which TV standard the DVD player is to use, available formats are NTSC, PAL and Multi/AUTO. (Multi/AUTO means that the video signal follows the format that is coded on the DVD you are watching.)
- Confirm the choice by pressing **OK**.

Parental control

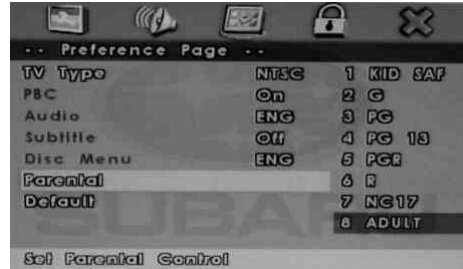

The Parental Control system has settings to allow you to block access to movies that are encoded with a movie content rating. The movie rating system is operated by the *Motion Picture Association of America*.

- Select setting:
 - 1 KID SAFE (children)
 - 2 G
 - 3 PG
 - 4 PG 13
 - 5 PGR
 - 6 R

7 NC-17

8 ADULT

Note!

The lower the value, the more strict the limitation

- Confirm your choice by pressing **OK**.
- Enter the password (6 digits) using the number buttons, and then press **OK**.

Note!

The default password is 136900.

DVD player

Default values

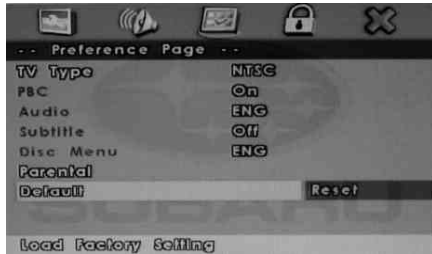

- Select **Default** to reset all settings on the DVD player to default settings.
- Press **OK** to perform the reset.



Note!

This function does not affect the setting for parental control.

Password Setup Page

Password Mode

When this function is selected, DVD films that are coded with a content classification will be password protected.

Password settings, parental control (password)



- To change the password for parental control:
 - Enter the old password or the preset password (6 digits) at **Old Password**.
 - Enter a new password (6 digits) with the number buttons at **New Password**.
 - Confirm the new password by entering the same password again at **Confirm PWD**.
- Then navigate to the **OK** button and press **OK** to activate the password.

Tip

Avoid grasping the side of the disc that contains information.

If there are spots on the disc, wipe it carefully using a damp cloth and then with a dry cloth.

When a disc is taken from a cold to hot environment condensation can build up on the surface of the disc. If so, wipe dry using a soft, dry cloth before use.









Caution!

Do not write on the unlabeled side.

Note!

- Do not use detergents, phenyl, chemical solutions, dispersing solutions, anti-static electricity solutions, or any other kind of solutions to clean a disc.
- Do not attach labels or glue-based notes on the disk. Do not use discs with any remaining glue or damaged, sticky labels.
- Do not use scratch-preventing materials or covers.
- Do not place or store discs in the following environments:
 - Direct sunlight
 - Damp or dusty locations.
 - At hot air outlets or other heat sources.

Icon display

Icon Display	Meaning of the icon
	The A.I.I function is turned on, and audio output from the selected monitor is started.
	The A.I.I function is turned off, and audio output from the selected monitor is halted.
	Indicates that the Aii Box has been connected (not seen in normal operation).
	Indicates that the Aii Box has been disconnected (not seen in normal operation).
	Activates a switch in the Aii module whenever a plug is inserted into the vehicle's AUX input jack.
	Activates a switch in the Aii module whenever a plug is removed from the vehicle's AUX input jack.
	Wrong side remote icon is shown if remote is set to one monitor (Left/Right) but pointed at the other when remote buttons are pressed.
	Mute On icon will display when there is no sound output. Mute Off icon will display when mute is turned off.
	"NO SIGNAL" will display in the event of video signal loss. If the PCB voltage is in the range of 10.3 to 9.1v, a three minute countdown is displayed. After the countdown above reached 1 minute, a one minute countdown is displayed in red.

Troubleshooting

Problem	Solution
No RSE sound is coming from the vehicle audio system	<ul style="list-style-type: none"> • Check that the vehicle's audio system is set to AUX input. • Check that there is no device plugged into the AUX port in the center console. • Check that the audio output (A.I.I.) is activated on the desired RSE unit.
IR sensor inoperative	<ul style="list-style-type: none"> • Check that the batteries in the remote control are not drained. • Check that the sensor eye on the remote control is not hidden. • Check the remote control is set to control the desired monitor.
Disc will not play	<ul style="list-style-type: none"> • Insert a disc with the label side up. • Check the disc type. In this DVD player, only DVDs, audio CDs and MP3 CDs can be played. • Both the device and disc are region coded. If the region codes do not correspond, the disc cannot be played. If you want to change region code, contact your Subaru dealer.
Play starts, but then stops immediately	<ul style="list-style-type: none"> • The disc is dirty, clean it. • There is a build up of condensation. Allow the player to dry.
No sound or distorted sound	<ul style="list-style-type: none"> • Check that the DVD player is properly connected. Ensure that all cables are properly connected to the correct sockets. • If you use IR headsets, check that the IR transmitter is on.

Troubleshooting









Problem	Solution
Cannot advance through a movie	<ul style="list-style-type: none">• You can't advance through the opening credits and warning information that appears at the beginning of movies because the disc is programmed to prohibit that action.
The icon (⓪) appears on the screen	<ul style="list-style-type: none">• The feature or action cannot be completed at this time because:<ul style="list-style-type: none">–The disc software restricts it.–The disc software doesn't support the feature (e.g. angles)–The feature is not available at the moment.–You requested a title or chapter number that is out of range.
The picture is distorted	<ul style="list-style-type: none">• The disc may be damaged. Try another disc.• Some distortion is normal when fast forwarding or rewinding.
No forward or reverse scan	<ul style="list-style-type: none">• On some discs there are sections where the fast forwarding or skipping of titles and chapters cannot be performed.• It is not possible to skip over warning information and text at the beginning of film. This part of the film is usually programmed not to be skipped.

Troubleshooting

Problem	Solution
The unit stopped unexpectedly	<ul style="list-style-type: none"> The thermal protection function may have powered down the unit. Please turn the unit off and wait until it cools down before resuming operation.
The unit is not responding to any of the commands from the remote control	<ul style="list-style-type: none"> Check that you pressed RIGHT or LEFT for the corresponding device. Check that the remote control batteries are not discharged.
The remote control does not seem to have power	<ul style="list-style-type: none"> Remove the screw from the back of the remote control with a coin or other hard object. Replace the battery, replace cover and tighten screw.
The multimedia system does not start	<ul style="list-style-type: none"> If the backlight flashes three times and then goes out and the device does not start when the power switch has been pressed, the vehicle's battery voltage is too low. Check/charge the battery. Check power wire fuse, located under the center console trim panel.
Language setting does not change	<ul style="list-style-type: none"> Language selection needs to be made in 2 places (DVD Setup and Display Menu). Note: The DVD Setup Menu can only be accessed when a DVD is inserted into the unit.
Cannot access DVD Menu	<ul style="list-style-type: none"> Change source to DVD mode.

EN Rear Seat Entertainment system

Default Settings

Menu Feature	Factory Setting
Brightness	 15
Contrast	 15
Color	 15
Tint	 15
Dimmer Mode	Normal Mode
Display Mode	Full Screen
 Volume	 15
 Power Control	On
 A.I.I. Control	Right On/ Left Off
Language	English

Les spécifications, données de construction et illustrations figurant dans cette publication ne sont pas contraignantes. Nous nous réservons le droit de les modifier sans préavis.

Renseignements généraux.		3
Avant d'utiliser le système.	3	
Survol du système.		4
Contenu de la trousse.	4	
Fonctions principales.	4	
Spécifications techniques.	5	
Guide rapide.		6
Lecture d'un film DVD.	3	
Utilisation des casques d'écoute sans fil.	6	
Lecture audio/vidéo par les entrées du port de jeux.	6	
Touches sur le panneau avant.		7
Commandes et connecteurs.	7	
Télécommande.		9
Touches et fonctions.	9	
AFFICHAGE.		11
Utilisation de l'affichage.	11	
Paramètres de l'écran d'affichage.	11	
MENU AFFICHAGE.	12	
Menu de commandes audio	13	
Menu de langues.	13	

Lecteur DVD	14
Utilisation du lecteur DVD	14
Paramètres du lecteur DVD	14
Configuration générale	15
Configuration audio	16
Préférences	17
Configuration du mot de passe	18
Manipulation des DVD	19
Conseils	19
Affichage des icônes	20
Signification des icônes	20
Dépannage	21
Dépannage	21
Paramètres par défaut	24
Paramètres par défaut	24

Avant d'utiliser le système

Remarque!

- Lire soigneusement le présent manuel de l'utilisateur avant d'utiliser l'appareil.
- Garder le manuel pour future référence.
- Observer soigneusement les instructions du manuel lors de l'utilisation de l'appareil.
- Ne jamais utiliser le système de divertissement d'une manière qui perturberait la conduite

Mise en garde!

- Les dommages causés par des réparations non autorisées ou les actualisations risquent d'annuler la garantie.
- Ne pas utiliser de solutions chimiques, d'agents de nettoyage ou corrosifs pour nettoyer l'écran d'affichage. Cela peut entraîner des dommages permanents à la surface de l'écran. Nous recommandons l'utilisation d'un chiffon doux humide pour lentilles pour éliminer la saleté ou les marques de doigts.
- Ne pas toucher ni pousser l'écran d'affichage lorsque l'appareil est en cours d'utilisation.
- Une force excessive peut causer des dommages permanents à la surface de l'écran.
- Verrouiller l'écran d'affichage en position fermée lorsqu'il n'est pas utilisé.
- Ne pas utiliser de disques DVD ou CD avec étiquettes adhésives. Ces étiquettes risquent de se détacher à l'intérieur de l'appareil et causer des dommages.
- Ne pas incliner ni déplacer le siège avant de façon à ce qu'il touche le toit.
- Ne pas incliner ni déplacer le siège avant de telle sorte qu'il touche les sièges d'enfant.

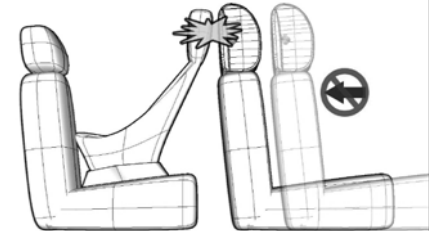

Survol du système

Contenu de la trousse

- 2 appuis-tête avec écran comprenant le Lecteur DVD
- 1 télécommande
- 2 casques d'écoute IR sans fil à deux canaux
- 6 piles AAA (4 pour les casques d'écoute et 2 pour la télécommande)
- 2 câbles d'adaptation pour l'entrée audio/vidéo
- 2 rallonges x 3,5 mm .

Accessoires en option

- Écouteurs supplémentaires IR sans fil double canal (numéro de pièce H001SAJ330)

Caractéristiques principales

- Écran LCD TFT 7 po avec appui-tête
- Lecteur DVD incorporé acceptant les DVD, VCD, AUDIO CD-R/RW et CD MP3.
- Émetteur IR pour les casques d'écoute sans fil
- 1 entrée audio/vidéo dans chaque appui-tête
- Télécommande sans fil toutes fonctions
- OSD (affichage à l'écran). Menu graphique servant à ajuster la qualité de l'image, l'image et la netteté.
- Intégré au système audio du véhicule.
Le son peut être émis par les haut-parleurs du véhicule.
- Commandes des fonctions principales intégrées au cadre avant.

Specifications techniques

Affichage	Écran large 7 po, matrice active DEL TFT
Résolution	800 (L) x 480 (H) x 3 (R.G.B.)
Pas de masque	0,0635 (L) x 0,1905 (H) mm
Angle de vision	50°/70°/70°/70° (du dessus/dessous/gauche/droite)
Luminosité	450 cd/m ²
Rapport de contraste	500:1
Puissance	12 V CC (masse négative)
Consommation	actif (DVD en cours de lecture) : approx. 20 W Max. (mise ne marche et insertion du disque) : approx. 32 W
Dimension du panneau	165 x 5,5 x 104 mm (L x P x H)
Systeme incorporé de contrôle de la température	Si la température dépasse +80 C (+175 F), le système s'éteint. <div style="border: 1px solid black; padding: 5px;"> <p>i Remarque!</p> <p>Le système surveille la température de la carte de circuit à l'intérieur de l'appareil et non la température ambiante extérieure dans l'habitacle.</p> </div>

Guide rapide

Passer un film DVD

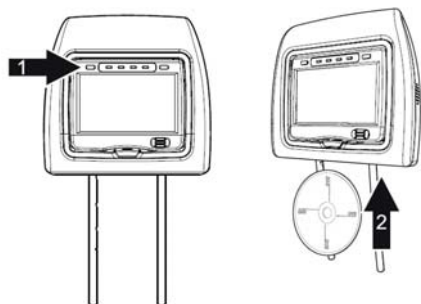

- Activer le système de divertissement en appuyant sur l'interrupteur (1) du panneau avant et insérer un DVD (2).

Utilisation des casques d'écoute sans fil

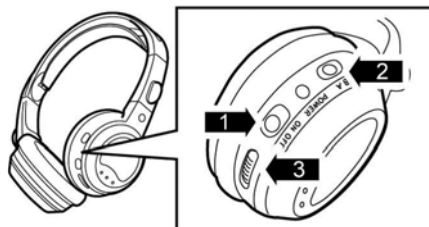

- Activer les écouteurs sans fil au moyen du contacteur d'alimentation (1).
- Sélectionner CH A pour la personne derrière le siège droit ou CH B si pour celle derrière le siège gauche (2).
- Régler le volume (3).

Remplacement des piles

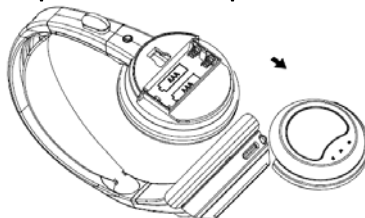

Lecture audio/vidéo par les entrées du port de jeux

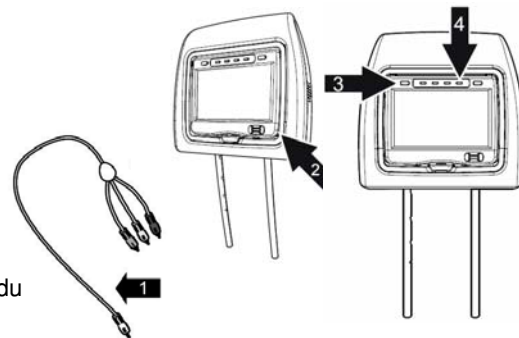

- Connecter l'appareil à utiliser le câblage de la mini-fiche/TRCA (1).
- Insérer la mini-fiche dans le port sous le panneau avant (2).
- Activer le système de divertissement en appuyant sur l'interrupteur d'alimentation (3) sur le panneau avant.
- Appuyer ensuite la touche **S** pour signal source (4) sur le panneau avant, jusqu'à ce que « AUX-AUDIO/VIDEO INPUT » s'affiche dans le coin supérieur droit de l'écran.

Commandes et connecteurs

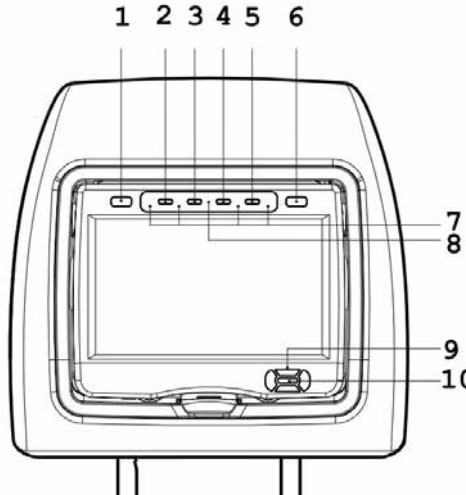

1 COMMANDE D'ALIMENTATION

Éteint et allume l'écran.

2 Titre

Appuyer sur cette touche pour revenir au menu racine du DVD.

3 Lecture/pause

Lecture et pause du disque.

4 ARRÊT

Arrête la lecture du disque.

- Appuyer deux fois sur **Stop** puis sur **Play** pour lire le disque depuis le début.
- Appuyer sur **Stop**, puis sur **Play** pour reprendre la lecture au dernier point d'arrêt.

5 Source des signaux

Commute entre les sources de signaux DVD, LEFT INPUT/RIGHT INPUT et AUX AUDIO/VIDEO INPUT. La sélection de LEFT INPUT/RIGHT INPUT comme source de signal pour un écran, les menus, affichage et audio à l'écran seront contrôlés par l'autre écran et la télécommande.

6 Menu

Ouvre le menu principal.

7 Émetteur IR

Transfère le son aux casques d'écoute sans fil.

8 Capteur IR

Reçoit les signaux infrarouges émis par la télécommande.

9 Touches de navigation

Appuyer dessus pour les retours en arrière/avance rapide piste suivante/antérieure et faire des choix dans les menus de titres DVD. Dans les menus DVD ou d'écrans, ils servent à régler et sélectionner les options.

10 Touche OK

Appuyer dessus pour confirmer les options de menu.

Touches sur le panneau avant

11 Prise pour casque d'écoute

Prise standard de 3,5 mm pour casque d'écoute.

12 Éjection

Lorsque l'appareil est sous tension, le disque s'éjecte sur pression de la touche d'éjection à côté de la fente DVD.

13 Entrée A/V

Prise d'entrée audio/vidéo de 3,5 mm. À utiliser avec le câble d'adaptation fourni.

14 Fente DVD

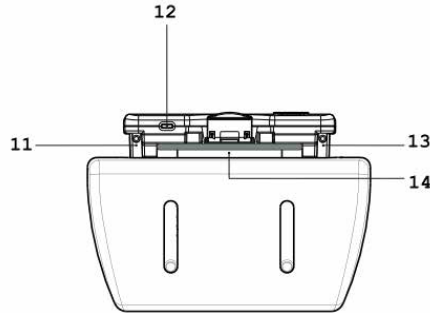

Touches et fonctions

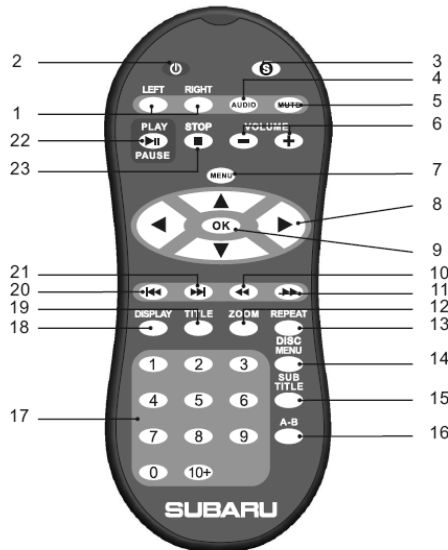

1 GAUCHE/DROIT

Appuyer pour sélectionner et contrôler l'écran de gauche et de droite.

2 COMMANDE D'ALIMENTATION

Appuyer pour alimenter l'écran sélectionné ou OFF (arrêt)

3 Source des signaux

Permet de commuter entre les différentes sources de signaux (DVD, LEFT INPUT/RIGHT INPUT et AUX AUDIO/VIDEO INPUT) pour l'écran sélectionné en appuyant sur la touche **S** plusieurs fois.

4 AUDIO

Maintenir pendant 1 sec. pour activer/désactiver la sortie radio RSE au système audio du véhicule.

5 SOURDINE

Appuyer une fois pour réduire la radio au silence. Appuyer de nouveau pour restaurer le son au volume antérieur.

6 VOLUME +/-

Augmente ou réduit le niveau sonore.

7 MENU

Ouvre le menu principal.
Active le menu du lecteur DVD.

8 Touches de navigation

Déplace l'option ou le curseur à gauche/droite/vers le haut/le bas.

9 OK

Appuyer pour confirmer la sélection.

10 Retour

Recherche en arrière.

11 Vers l'avant

Recherche vers l'avant.

12 ZOOM

Grossit ou réduit l'image. Utiliser les touches de navigation pour centrer l'image grossie.

13 RÉPÉTER

Répète la lecture de différentes parties d'un DVD, CD ou MP3 (piste/chapitre/option).

14 MENU DU DISQUE

Commute entre les sous-textes disponibles pendant la lecture de VCD 2.0. Chemin au menu des options du titre de DVD.

15 SOUS-TITRE

Commute entre les options de langues, le cas échéant.

Télécommande

16 AB

Permet de répéter la lecture d'un DVD ou d'un CD du point A au point B. Paramétrer le point A en appuyant une fois, appuyer de nouveau pour le point B. Appuyez à nouveau pour effacer les valeurs de réglage.

17 Clavier numérique

Accès direct aux pistes de CD, chapitres de DVD et configuration d'un mot de passe.

18 AFFICHAGE

Montre des informations sur les médias en cours.

19 TITRE

Sur certains DVD, il est possible de sélectionner le titre. Sélectionner le titre désiré à l'aide de cette touche.

20 Piste précédente

Revient au chapitre ou à la piste précédente.

21 Piste suivante

Passes au chapitre ou à la piste suivante.

22 Lecture/pause

Commence la lecture ou une fonction. Fait une pause dans la lecture sur nouvelle pression de la touche.

23 ARRÊT

Arrête la lecture.

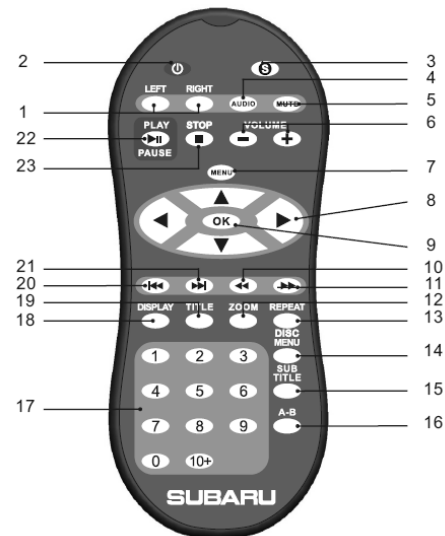

Remplacement des piles

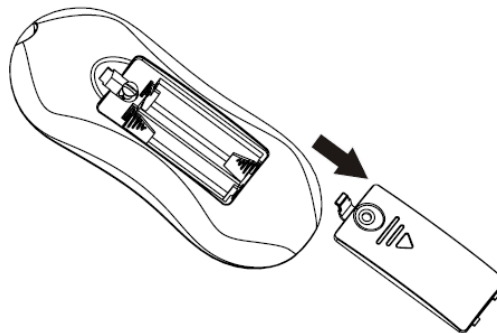

Utilisation de l'écran

- 1 Il est possible de régler l'écran à un angle d'affichage confortable pour éliminer les reflets ou éblouissements en l'inclinant.
- 2 Appuyer sur la touche de mise sous tension sur le panneau avant ou la télécommande pour mettre l'écran d'affichage sous tension.

Remarque!

Si le rétro-éclairage clignote trois fois, s'éteint et l'appareil ne se met pas en marche, la tension de la batterie du véhicule est trop faible.

- 3 Appuyer sur la touche **S** pour sélectionner le signal source. Choisir une des options suivantes :

- **DVD** utilise le lecteur DVD de l'appareil
- **LEFT INPUT/RIGHT INPUT**
utilise le lecteur DVD correspondant ou AUX AUDIO/VIDEO INPUT.
Si le lecteur DVD correspondant n'émet aucun signal, « NO DISC » s'affiche.

- **AUX AUDIO/VIDEO INPUT** utilise l'entrée AUX connectée.

Paramètres de l'écran d'affichage



Pour changer les paramètres d'affichage, ouvrir le menu principal en appuyant sur la touche **MENU** de la télécommande ou sur la touche **MENU** du panneau avant.

Les paramètres de luminosité, contraste, couleur, audio, etc., se règlent dans le MENU AFFICHAGE.

AFFICHAGE

Modification des paramètres

Appuyer sur les touches de navigation de la télécommande ou du panneau avant pour sélectionner les paramètres à modifier. Utiliser les touche gauche/droite pour réduire ou hausser la valeur de l'option sélectionnée. Ne pas appuyer sur une touche dans les 7 secondes, ramène l'écran à son mode d'affichage normal.

MENU AFFICHAGE



LUMINOSITÉ

Ajuste l'intensité de l'éclairage du fond.

CONTRASTE

Règle le contraste.

COULEUR

Ajuste l'équilibre entre bleu, jaune et rouge.

TEINTE

Ajuste l'intensité du bleu, jaune et rouge

MODE ATTÉNUATEUR

Sélectionner entre les modes sombre, normal ou lumineux

MODE AFFICHAGE

Sélectionner PLEIN ÉCRAN ou 4:3 de rapport de cadre

VOLUME Câblé

Règle le volume des casques d'écoute câblés.



COMMANDE IR

Met sous/hors tension l'émetteur IR des casques d'écoute sans fil.

COMMANDE AUDIO (A.I.I.)

Ce paramètre permet de décider quel son du lecteur CD DVD sera envoyé au système audio du véhicule. Lorsque les deux écrans d'affichage sont sous tension le paramètre par défaut est « ACTIVÉ » à droite et « DÉSACTIVÉ » à gauche.

En modifiant l'un des moniteurs à « ACTIVÉ », le son de ce moniteur est acheminé au système audio du véhicule et l'autre moniteur passe automatiquement à « DÉSACTIVÉ ».

Au branchement d'un appareil dans la prise d'entrée AUX de la console centrale du véhicule, l'icône  apparaît sur l'écran RSE et la sortie Aii est désactivée. Au débranchement de l'appareil, l'icône  apparaît et le son peut être émis par le système audio du véhicule.

Si SOURDINE (AUCUN SON) est activé,  s'affiche à l'écran.

LANGUE

Sélectionner la langue préférée sur les menus d'affichage. Anglais, français, allemand sont disponibles.

RÉINITIALISATION AUX PARAMÈTRES D'ORIGINE

Réinitialise les affichages à l'écran aux paramètres d'origine.

Lecteur DVD

Utilisation du lecteur DVD.



Remarque!

Lire ce chapitre à fond avant d'utiliser le lecteur DVD.

Le lecteur DVD peut lire des DVD, VCD, audio CD-R/RW et CD MP3.

Codes régionaux

Le lecteur DVD et les disques DVD sont codés par région. Ces codes régionaux doivent correspondre entre eux pour que le disque puisse être lu. Si les codes ne correspondent pas, le disque ne sera pas lisible. Pour changer le code régional, prière de consulter son concessionnaire Subaru.

Lecture d'un DVD ou VCD

- 1 Appuyer sur la touche **S** jusqu'à ce que « DVD » s'affiche.
- 2 Insérer un disque DVD ou VCD (étiquette vers le haut), le disque se charge automatiquement.
- 3 Appuyer sur la touche **PLAY** pour lancer la lecture du titre sélectionné.



Remarque!

« INCORRECT REGION » apparaît à l'écran si le code régional du disque n'est pas correct.

- 4 Appuyer sur la touche **Pause** pour faire une pause de lecture, appuyer une fois de plus pour continuer la lecture.
- 5 Appuyer sur la touche **Stop** pour arrêter la lecture.

Paramètres du lecteur DVD

Pour changer les paramètres sur le lecteur DVD, appuyer sur la touche **MENU** de la télécommande ou la touche **MENU** du panneau avant pour ouvrir le menu principal et sélectionner le sous-menu « DVD SETUP ».

Le menu DVD permet d'exécuter des réglages élémentaires, d'ajuster la qualité de l'image et de sélectionner différentes sorties. Il est également possible de sélectionner la langue du texte à l'écran, ainsi que le menu de paramètres, et de contrôler ce que passent les enfants.

Les icônes sur la rangée supérieure symbolisent les pages où il est possible de paramétrer le lecteur de DVD :

- Page de configuration générale
- Page de configuration audio
- Page de préférences
- Page de configuration du mot de passe

Modification des paramètres

Sélectionner la page recherchée en déplaçant le curseur à l'aide des touches de navigation Appuyer sur **OK** pour confirmer le choix.

Appuyez sur la touche de gauche à plusieurs reprises, au besoin, pour sélectionner différents réglages de page.

Pour sortir des paramètres et du menu, appuyer sur **MENU** de nouveau.

Page de configuration générale

Affichage téléviseur

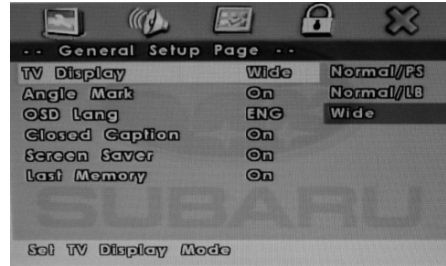

— Sélectionner les paramètres d'affichage parmi les options suivantes :

- **Normal/PS** (panoramique et balayage)
Affichage d'une image large à l'écran avec une partie des côtés gauche et droit éliminée.
- **Normal/LB** (boîte aux lettres)
Affichage d'une image large avec bandes noires en haut et en bas de l'écran.

- **Wide** (16:9)

L'illustration montre un écran large au format 16:9. C'est le réglage conseillé

— Appuyer sur **OK** pour confirmer le choix.

Marqueur d'angle

À la sélection de la fonction Angle Mark, un icône s'affiche indiquant si le DVD a une double piste (p. ex., piste de commentaires). Appuyer sur **OK** pour sélectionner cette piste.

Lecteur DVD

Langue du menu DVD (OSD Lang)

Lang)

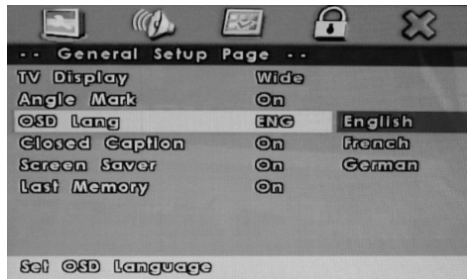

- Sélectionner la langue sur ce menu sous **OSD Lang**. Les langues disponibles sont l'anglais, le français et l'allemand.
- Appuyer sur **OK** pour confirmer le choix.

Sous-titres codés

Fonction spéciale pour les personnes malentendantes où sont décrits par des textes certains effets audio à la sélection de Closed Caption.

Économiseur d'écran

Un économiseur d'écran apparaît si l'appareil est sous tension sans fonctionner pendant 3 minutes. Appuyer sur n'importe quelle touche pour revenir à l'image précédente.

LAST MEMORY

Après une mise hors tension, le DVD en cours de lecture reprend où il s'est arrêté lorsqu'il est de nouveau sous tension, si cette fonction est sélectionnée.

Page de configuration audio

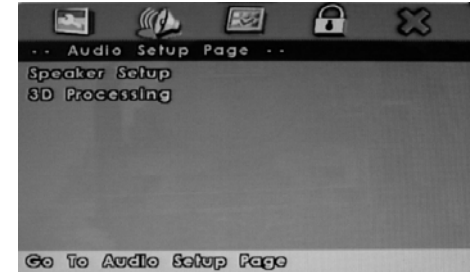

- Sélectionner haut-parleur et paramètres audio.

Page de préférences

Remarque!

Les options des menus Disc Menu, Audio et Subtitle ne sont pas disponibles dans ce système. Il est impossible d'avoir accès à la page de références quand un disque est chargé.

Normes de télévision (type de télé)

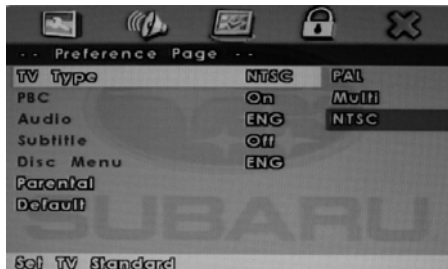

- Sélectionner quelle norme télé le lecteur DVD doit utiliser; les formats disponibles sont NTSC, PAL et Multi/AUTO. (Multi/AUTO signifie que signal vidéo suit le format codé sur le DVD en cours de lecture.)
- Appuyer sur **OK** pour confirmer le choix.

Contrôle parental

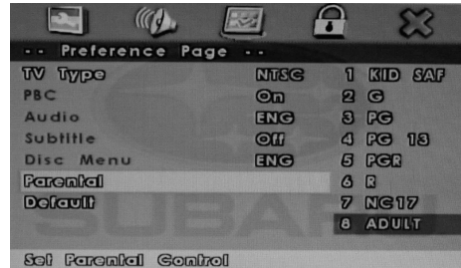

Le système de contrôle parental dispose de paramètres qui permettent de bloquer l'accès à des films qui sont cotés en fonction de leur contenu.

Le système de cotation des films est sous l'égide de la *Motion Picture Association of America*.

- Sélectionner le paramètre :
 - 1 KID SAFE (enfants)
 - 2 G
 - 3 PG
 - 4 PG 13
 - 5 PGR
 - 6 R

7 NC-17

8 ADULT

Remarque!

Plus la valeur est basse, plus la limite est stricte

- Appuyer sur **OK** pour confirmer le choix.
- Saisir le mot de passe (6 chiffres) à l'aide des touches de chiffres et appuyer sur **OK**.

Remarque!

Le mot de passe par défaut est 136900.

Lecteur DVD

Valeurs par défaut

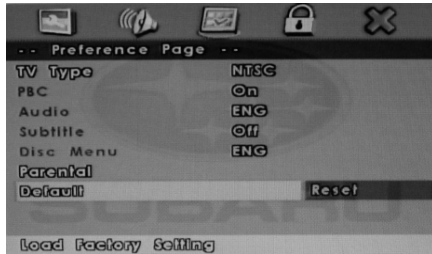

- Sélectionner **Default** pour réinitialiser tous les paramètres du lecteur DVD à ceux d'origine.
- Appuyer sur **OK** pour réinitialiser.

Remarque!

Cette fonction n'affecte pas le paramètre de contrôle parental.

Page de configuration du mot de passe

Mode mot de passe

Quand cette fonction est sélectionnée, les films DVD codés en fonction de leur contenu sont protégés par le mot de passe.

Configuration du mot de passe, contrôle parental (mot de passe)

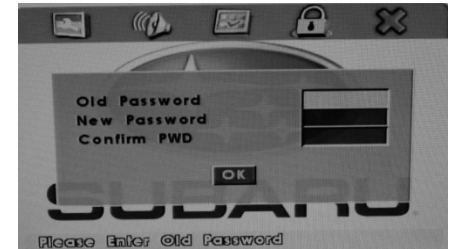
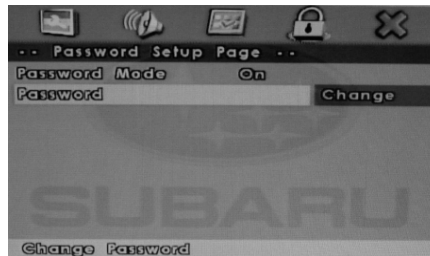

- Changement du mot de passe de contrôle parental :
Entrer l'ancien mot de passe ou celui préétabli (6 chiffres) à **Old Password**.
- Entrer un nouveau mot de passe (6 chiffres) à l'aide du clavier numérique à **New Password**.
- Confirmer le nouveau mot de passe par la saisie du même mot de passe à **Con rm PWD**.
- Passer ensuite à la touche **OK** et appuyer sur **OK** pour activer le mot de passe.

Conseil

Éviter de toucher le côté du disque qui contient les informations.
S'il y a des taches sur le disque, les essuyer soigneusement avec un chiffon humide, puis un chiffon sec.
Quand un disque passe d'un milieu froid à un milieu chaud, de la condensation peut se former à sa surface. Si c'est le cas le sécher à l'aide d'un chiffon doux et sec avant utilisation.



Mise en garde!







Ne pas écrire sur la face sans étiquette.



Remarque!

- Ne pas utiliser de détergents, phényle, solutions chimiques, solutions dispersantes, solutions contre l'électricité statique, ou tout autre type de solutions pour nettoyer un disque.
- Ne pas fixer d'étiquettes ou de notes à coller sur le disque. Ne pas utiliser de disques avec des restes de colle ou d'étiquette endommagée, collante.
- Ne pas utiliser de produits ou de protection contre les rayures.
- Ne pas placer ou ranger les disques dans les endroits suivants :
 - Lumière solaire directe
 - Endroits humides ou poussiéreux.
 - À des sorties d'air chaud ou autres sources de chaleur.

Affichage d'icônes

Affichage d'icônes	Signification de l'icône
 Aii activée	La fonction A.I.I. est activée et la sortie audio du moniteur sélectionné se met en marche.
 Aii désactivée	La fonction A.I.I. est désactivée et la sortie audio du moniteur sélectionné est arrêtée.
Boîte Aii connectée	Indique que la boîte Aii a été connectée (invisible en cours de fonctionnement normal).
 Boîte Aii déconnectée	Indique que la boîte Aii a été déconnectée (invisible en cours de fonctionnement normal).
Fiche Aii Aux insérée	Active un interrupteur dans le module Aii lorsqu'une fiche est insérée dans la prise d'entrée AUX du véhicule.
 Fiche Aii Aux retirée	Active un interrupteur dans le module Aii lorsqu'une fiche est retirée de la prise d'entrée AUX du véhicule.
 Icône de télécommande du mauvais côté	L'icône de télécommande du mauvais côté s'affiche si la télécommande est réglée sur un moniteur (gauche/droit), mais pointée à l'autre au moment d'appuyer sur les touches.
 Sourdine activée/désactivée	L'icône de sourdine activée s'affiche lorsque le son est coupé. L'icône de sourdine désactivée s'affiche lorsque le son est rétabli.
 « NO SIGNAL »	« NO SIGNAL » s'affiche en cas de perte du signal vidéo. Si la tension PCB oscille entre 10,3 et 9,1 V, un décompte de trois minutes s'affiche. Dès que le décompte atteint 1 minute, un décompte d'une minute s'affiche en rouge.



Dépannage









Problème	Solution
Aucun son RSE ne sort du système audio du véhicule	<ul style="list-style-type: none"> •Vérifier que le système audio du véhicule est réglé sur l'entrée AUX. •Vérifier qu'il n'y a aucun appareil branché sur le port AUX de la console centrale. •Vérifier que la sortie audio (A.I.I.) est activée sur l'unité RSE souhaitée.
Capteur IR inopérant	<ul style="list-style-type: none"> •Vérifier que les piles de la télécommande ne sont pas usées. • Vérifier que le viseur du capteur sur la télécommande n'est pas occulté. •Vérifier que la télécommande est réglée sur le moniteur désiré.
Le disque ne se lit pas	<ul style="list-style-type: none"> •Insérer un disque étiquette dirigée vers le haut. •Vérifier le type de disque. Dans ce lecteur DVD, seuls les DVD, CD audio et CD MP3 peuvent être lus. • L'appareil et le disque sont codés par région. Si les codes régionaux ne correspondent pas, le disque ne peut pas être lu. • Pour toute intention de changer de code régional, communiquer avec le concessionnaire Subaru.
La lecture commence, mais s'arrête immédiatement	<ul style="list-style-type: none"> •Le disque est sale, le nettoyer. •La condensation s'est accumulée. Laisser sécher le lecteur.
Aucun son ou le son est déformé	<ul style="list-style-type: none"> •Vérifier que le lecteur DVD est correctement connecté. S'assurer que tous les câbles sont correctement branchés aux prises qui leur sont réservées. •En cas d'utilisation des casques d'écoute IR, vérifier que l'émetteur IR est sous tension.

Dépannage

Problème	Solution
Impossible de faire avancer le film	<ul style="list-style-type: none">• Impossible de passer le générique et les informations de mise en garde qui apparaissent au début des films parce que le disque est programmé pour l'interdire.
L'icône (Ø) apparaît à l'écran	<ul style="list-style-type: none">• Impossible de mener pour le moment cette fonction ou action à bien parce que : Le logiciel du disque le restreint. Le logiciel du disque ne prend pas en charge la fonction (p. ex., angles) La fonction n'est pas disponible pour le moment. Demande de titre ou de chapitre hors limite.
L'image est déformée	<ul style="list-style-type: none">• Le disque est peut-être endommagé. Essayer un autre disque.• Une certaine déformation est normale en avance ou recul rapide.
Aucun balayage avant ou arrière	<ul style="list-style-type: none">• Sur certains disques il est impossible d'exécuter l'avance rapide des titres ou chapitres ou de les sauter.• Il n'est pas possible d'éviter les données et textes de mise en garde au début des films. Cette section est d'ordinaire programmée pour ne pas être sautée.

Problème	Solution
L'appareil s'est arrêté de façon imprévue	<ul style="list-style-type: none"> • Il se peut que la fonction de protection thermique ait mis l'appareil hors tension. Éteindre l'appareil et attendre qu'il refroidisse avant de reprendre la lecture.
L'appareil ne réagit à aucune des commandes de la télécommande	<ul style="list-style-type: none"> • Vérifier que DROITE ou GAUCHE correspondent bien à l'appareil sélectionné. • Vérifier que les piles de la télécommande ne sont pas déchargées.
Il semblerait que la télécommande ne soit pas alimentée	<ul style="list-style-type: none"> • Retirer la vis au dos de la télécommande à l'aide d'une pièce de monnaie ou autre objet. Remplacer les piles, remettre le couvercle et serrer la vis.
Le système multimédia ne se met pas en marche	<ul style="list-style-type: none"> • Si le rétro-éclairage clignote trois fois puis s'éteint et que l'appareil ne se met pas en marche après avoir appuyé sur la touche d'alimentation, la batterie du véhicule est trop faible. Vérifier/charger la batterie. • Vérifier le fusible d'alimentation, situé sous le panneau de garniture de console centrale.
Les paramètres de langue ne changent pas	<ul style="list-style-type: none"> • La sélection de la langue doit se faire en deux endroits (Configuration DVD et Menu affichage). • Remarque : L'accès au menu de configuration des DVD n'est possible qu'avec un DVD inséré dans l'appareil.
Impossible d'avoir accès au menu DVD	<ul style="list-style-type: none"> • Changer la source à Mode DVD.

Paramètres par défaut

Fonctions du menu	Réglages d'origine
Luminosité	 15
Contraste	 15
Couleur	 15
Teinte	 15
Mode atténuateur	Mode normal
Mode affichage	Plein écran
 Volume	 15
 Alimentation	Activé
 Commande A.I.I.	Droite activée/gauche désactivée
Langue	Anglais



Foreword

Congratulations on choosing a SUBARU vehicle. This Owner's Manual has all the information necessary to keep your SUBARU in excellent condition and to properly maintain the emission control system for minimizing emission pollutants. We urge you to read this manual carefully so that you may understand your vehicle and its operation. For information not found in this Owner's Manual, such as details concerning repairs or adjustments, please contact the SUBARU dealer from whom you purchased your SUBARU or the nearest SUBARU dealer.

The information, specifications and illustrations found in this manual are those in effect at the time of printing. FUJI HEAVY INDUSTRIES LTD. reserves the right to change specifications and designs at any time without prior notice and without incurring any obligation to make the same or similar changes on vehicles previously sold. This Owner's Manual applies to all models and covers all equipment, including factory installed options. Some explanations, therefore may be for equipment not installed in your vehicle.

Please leave this manual in the vehicle at the time of resale. The next owner will need the information found herein.

FUJI HEAVY INDUSTRIES LTD., TOKYO, JAPAN



SUBARU is a registered trademark of FUJI HEAVY INDUSTRIES LTD.

© Copyright 2011 FUJI HEAVY INDUSTRIES LTD.

This manual describes the following types of the Legacy series.

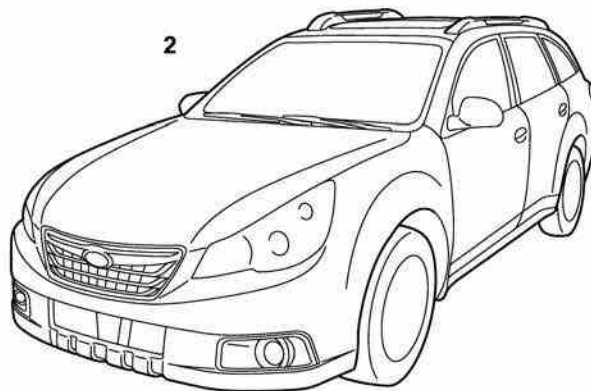
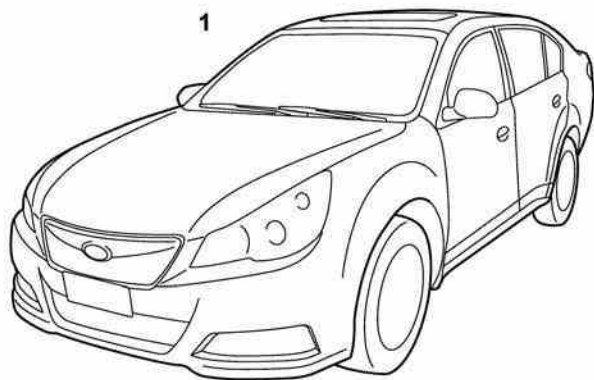

000611

- 1) Legacy
- 2) Outback

Warranties

■ Warranties for U.S.A.

All SUBARU vehicles distributed by Subaru of America, Inc. and sold at retail by an authorized SUBARU dealer in the United States come with the following warranties:

- SUBARU Limited Warranty
- Emission Control Systems Warranty
- Emissions Performance Warranty

All warranty information, including details of coverage and exclusions, is in the "Warranty and Maintenance Booklet". Please read these warranties carefully.

■ Warranties for Canada

All SUBARU vehicles distributed by Subaru Canada, Inc. and sold at retail by an authorized SUBARU dealer in Canada come with the following warranties:

- SUBARU Limited Warranty
- Anti-Corrosion Warranty
- Emission Control Warranty

All warranty information, including details of coverage and exclusions, is in the "Warranty and Service Booklet". Please read these warranties carefully.

How to use this Owner's Manual

■ Using your Owner's Manual

Before you operate your vehicle, carefully read this manual. To protect yourself and extend the service life of your vehicle, follow the instructions in this manual. Failure to observe these instructions may result in serious injury and damage to your vehicle.

This manual is composed of fourteen chapters. Each chapter begins with a brief table of contents, so you can usually tell at a glance if that chapter contains the information you want.

Chapter 1: Seat, seatbelt and SRS airbags

This chapter informs you how to use the seat and seatbelt and contains precautions for the SRS airbags.

Chapter 2: Keys and doors

This chapter informs you how to operate the keys, locks and windows.

Chapter 3: Instruments and controls

This chapter informs you about the operation of instrument panel indicators and how to use the instruments and other switches.

Chapter 4: Climate control

This chapter informs you how to operate the climate control.

Chapter 5: Audio

This chapter informs you how to operate your audio system.

Chapter 6: Interior equipment

This chapter informs you how to operate interior equipment.

Chapter 7: Starting and operating

This chapter informs you how to start and operate your SUBARU.

Chapter 8: Driving tips

This chapter informs you how to drive your SUBARU in various conditions and explains some safety tips on driving.

Chapter 9: In case of emergency

This chapter informs you what to do if you have a problem while driving, such as a flat tire or engine overheating.

Chapter 10: Appearance care

This chapter informs you how to keep your SUBARU looking good.

Chapter 11: Maintenance and service

This chapter informs you when you need to take your SUBARU to the dealer for scheduled maintenance and informs you how to keep your SUBARU running properly.

Chapter 12: Specifications

This chapter informs you about the dimensions and capacities of your SUBARU.

Chapter 13: Consumer information and Reporting safety defects

This chapter informs you about Tire information, Uniform tire quality grading standards and Reporting safety defects.

Chapter 14: Index

This is an alphabetical listing of all that's in this manual. You can use it to quickly find something you want to read.

■ Safety warnings

You will find a number of WARNINGS, CAUTIONS and NOTES in this manual.

These safety warnings alert you to potential hazards that could result in injury to you or others.

Please read these safety warnings as well as all other portions of this manual carefully in order to gain a better understanding of how to use your SUBARU vehicle safely.



WARNING

A WARNING indicates a situation in which serious injury or death could result if the warning is ignored.



CAUTION

A CAUTION indicates a situation in which injury or damage to your vehicle, or both, could result if the caution is ignored.

NOTE

A NOTE gives information or suggestions how to make better use of your vehicle.

■ Safety symbol



You will find a circle with a slash through it in this manual. This symbol means “Do not”, “Do not do this”, or “Do not let this happen”, depending upon the context.

■ Abbreviation list

You will find several abbreviations in this manual. The meanings of the abbreviations are shown in the following list.









Abbreviation	Meaning
A/C	Air conditioner
A/ELR	Automatic/Emergency locking retractor
ABS	Anti-lock brake system
AKI	Anti knock index
ALR	Automatic locking retractor
AT	Automatic transmission
ATF	Automatic transmission fluid
AWD	All-wheel drive
CVT	Continuously variable transmission
DRL	Daytime running light
EBD	Electronic brake force distribution
ELR	Emergency locking retractor
FWD	Front-wheel drive
GAW	Gross axle weight
GAWR	Gross axle weight rating
GPS	Global positioning system
GVW	Gross vehicle weight
GVWR	Gross vehicle weight rating











Abbreviation	Meaning
HID	High intensity discharge
INT	Intermittent
LATCH	Lower anchors and tethers for children
LED	Light emitting diode
LSD	Limited slip differential
MIL	Malfunction indicator light
MMT	Methylcyclopentadienyl manganese tricarbonyl
MT	Manual transmission
OBD	On-board diagnostics
RON	Research octane number
SI-DRIVE	SUBARU Intelligent Drive
SRS	Supplemental restraint system
TIN	Tire identification number
TPMS	Tire pressure monitoring system
VDC	Vehicle dynamics control

Vehicle symbols











There are some of the symbols you may see on your vehicle.







For warning and indicator lights, refer to "Warning and indicator lights" 19.

Mark	Name
	WARNING
	CAUTION
	Power door lock
	Power door unlock
	Power window with automatic open and close function
	Passengers' windows lock
	Fuel
	Front fog lights
	Hazard warning flasher

Mark	Name
	Seat heater
	Child restraint lower anchorages
	Child restraint top tether anchorages
	Horn
	Windshield wiper
	Windshield washer
	Rear window wiper
	Rear window washer
	Lights
	Tail lights, license plate light and instrument panel illumination
	Headlights

– CONTINUED –

Mark	Name
	Turn signal
	Illumination brightness
	Engine hood
	Trunk lid (Legacy)
	Fan speed
	Instrument panel outlets
	Instrument panel outlets and foot outlets
	Foot outlets
	Windshield defroster and foot outlets
	Windshield defroster
	Rear window defogger/Outside mirror defogger/Windshield wiper deicer

Mark	Name
	Air recirculation
	Engine oil
	Washer
	Door lock (transmitter)
	Door unlock (transmitter)
	Trunk lid open (Legacy) or rear gate unlock (Outback) (transmitter)

Safety precautions when driving

■ Seatbelt and SRS airbag



WARNING

- All persons in the vehicle should fasten their seatbelts **BEFORE** the vehicle starts to move. Otherwise, the possibility of serious injury becomes greater in the event of a sudden stop or accident.
 - To obtain maximum protection in the event of an accident, the driver and all passengers in the vehicle should always wear seatbelts when the vehicle is moving. The SRS (Supplemental Restraint System) airbag does not do away with the need to fasten seatbelts. In combination with the seatbelts, it offers the best combined protection in case of a serious accident.
- Not wearing a seatbelt increases the chance of severe injury or death in a crash even when the vehicle has the SRS airbag.

- The SRS airbags deploy with considerable speed and force. Occupants who are out of proper position when the SRS airbag deploys could suffer very serious injuries. Because the SRS airbag needs enough space for deployment, the driver should always sit upright and well back in the seat as far from the steering wheel as practical while still maintaining full vehicle control and the front passenger should move the seat as far back as possible and sit upright and well back in the seat.

For instructions and precautions, carefully read the following sections.

- For the seatbelt system, refer to “Seatbelts” 1-12.
- For the SRS airbag system, refer to “*SRS airbag (Supplemental Restraint System airbag)” 1-36.

■ Child safety



WARNING

- Never hold a child on your lap or in your arms while the vehicle is moving. The passenger cannot protect the child from injury in a collision, because the child will be caught between the passenger and objects inside the vehicle.
- While riding in the vehicle, infants and small children should always be placed in the REAR seat in an infant or child restraint system which is appropriate for the child’s age, height and weight. If a child is too big for a child restraint system, the child should sit in the REAR seat and be restrained using the seatbelts. According to accident statistics, children are safer when properly restrained in the rear seating positions than in the front seating positions. Never allow a child to stand up or kneel on the seat.
- Put children in the REAR seat properly restrained at all times in a child restraint device or in a seatbelt. The SRS airbag deploys

with considerable speed and force and can injure or even kill children, especially if they are not restrained or improperly restrained. Because children are lighter and weaker than adults, their risk of being injured from deployment is greater.

- NEVER INSTALL A REARWARD FACING CHILD SAFETY SEAT IN THE FRONT SEAT. DOING SO RISKS SERIOUS INJURY OR DEATH TO THE CHILD BY PLACING THE CHILD’S HEAD TOO CLOSE TO THE SRS AIRBAG.
- Always turn the child safety locks to the “LOCK” position whenever a child rides in the rear seat. Serious injury could result if a child accidentally opened the door and fell out. Refer to “Child safety locks” 2-19.
- Always lock the passengers’ windows using the lock switch when children are riding in the vehicle. Failure to follow this procedure could result in injury to a child operating the power window. Refer to “Windows” 2-20.
- Never leave unattended children, adults or animals in the vehicle.

They could accidentally injure themselves or others through inadvertent operation of the vehicle. Also, on hot or sunny days, the temperature in a closed vehicle could quickly become high enough to cause severe or possibly fatal injuries.

- Help prevent children, adults or animals from locking themselves in the trunk. On hot or sunny days, the temperature in the trunk could quickly become high enough to cause death or serious heat-related injuries including brain damage to anyone locked inside, particularly for small children.
- When leaving the vehicle, close all windows and lock all doors. Also make certain that the trunk is closed.

For instructions and precautions, carefully read the following sections.

- For the seatbelt system, refer to “Seatbelts” 1-12.
- For the child restraint system, refer to “Child restraint systems” 1-23.
- For the SRS airbag system, refer to “*SRS airbag (Supplemental Restraint

System airbag)” 1-36.

■ Engine exhaust gas (carbon monoxide)

WARNING

- Never inhale engine exhaust gas. Engine exhaust gas contains carbon monoxide, a colorless and odorless gas which is dangerous, or even lethal, if inhaled.
- Always properly maintain the engine exhaust system to prevent engine exhaust gas from entering the vehicle.
- Never run the engine in a closed space, such as a garage, except for the brief time needed to drive the vehicle in or out of it.
- Avoid remaining in a parked vehicle for a long time while the engine is running. If that is unavoidable, then use the ventilation fan to force fresh air into the vehicle.
- Always keep the front ventilator inlet grille free from snow, leaves or other obstructions to ensure that the ventilation system always works properly.

- If at any time you suspect that exhaust fumes are entering the vehicle, have the problem checked and corrected as soon as possible. If you must drive under these conditions, drive only with all windows fully open.
- Keep the trunk lid or rear gate closed while driving to prevent exhaust gas from entering the vehicle.

■ Drinking and driving

WARNING

Drinking and then driving is very dangerous. Alcohol in the bloodstream delays your reaction and impairs your perception, judgment and attentiveness. If you drive after drinking – even if you drink just a little – it will increase the risk of being involved in a serious or fatal accident, injuring or killing yourself, your passengers and others. In addition, if you are injured in the accident, alcohol may increase the severity of that injury.

Please don't drink and drive.

Drunken driving is one of the most frequent causes of accidents. Since alcohol affects all people differently, you may have consumed too much alcohol to drive safely even if the level of alcohol in your blood is below the legal limit. The safest thing you can do is never drink and drive. However if you have no choice but to drive, stop drinking and sober up completely before getting behind the wheel.

■ **Drugs and driving**

 **WARNING**

There are some drugs (over the counter and prescription) that can delay your reaction time and impair your perception, judgment and attentiveness. If you drive after taking them, it may increase your, your passengers' and other persons' risk of being involved in a serious or fatal accident.

If you are taking any drugs, check with your doctor or pharmacist or read the literature that accompanies the medication to determine if the drug you are taking can impair your driving ability. Do not drive

after taking any medications that can make you drowsy or otherwise affect your ability to safely operate a motor vehicle. If you have a medical condition that requires you to take drugs, please consult with your doctor.

Never drive if you are under the influence of any illicit mind-altering drugs. For your own health and well-being, we urge you not to take illegal drugs in the first place and to seek treatment if you are addicted to those drugs.

■ **Driving when tired or sleepy**

 **WARNING**

When you are tired or sleepy, your reaction will be delayed and your perception, judgment and attentiveness will be impaired. If you drive when tired or sleepy, your, your passengers' and other persons' chances of being involved in a serious accident may increase.

Please do not continue to drive but instead find a safe place to rest if you are tired or sleepy. On long trips, you should make periodic rest stops to refresh yourself before continuing on your journey. When possible, you should share the

driving with others.

■ **Car phone/cell phone and driving**

 **CAUTION**

Do not use a car phone/cell phone while driving; it may distract your attention from driving and can lead to an accident. If you use a car phone/cell phone, pull off the road and park in a safe place before using your phone. In some States/Provinces, only hands-free phones may legally be used while driving.

■ Modification of your vehicle

CAUTION

Your vehicle should not be modified other than with genuine SUBARU parts and accessories. Other types of modifications could affect its performance, safety or durability, and may even violate governmental regulations. In addition, damage or performance problems resulting from modification may not be covered under warranties.

■ Driving with pets

Unrestrained pets can interfere with your driving and distract your attention from driving. In a collision or sudden stop, unrestrained pets or cages can be thrown around inside the vehicle and hurt you or your passengers. Besides, the pets can be hurt under these situations. It is also for their own safety that pets should be properly restrained in your vehicle. Restrain a pet with a special traveling harness which can be secured to the rear seat with a seatbelt or use a pet carrier which can be secured to the rear seat by routing a seatbelt through the carrier's handle. Never restrain pets or pet carriers

in the front passenger's seat. For further information, consult your veterinarian, local animal protection society or pet shop.

■ Tire pressures

WARNING

Driving at high speeds with excessively low tire pressures can cause the tires to deform severely and to rapidly become hot. A sharp increase in temperature could cause tread separation, and destruction of the tires. The resulting loss of vehicle control could lead to an accident.

Check and, if necessary, adjust the pressure of each tire (including the spare) at least once a month and before any long journey.

Check the tire pressure when the tires are cold. Use a pressure gauge to adjust the tire pressures to the values shown on the tire placard. For detailed information, refer to "Tires and wheels"  11-30.

■ California proposition 65 warning

WARNING

Engine exhaust, some of its constituents, and certain vehicle components contain or emit chemicals known to the State of California to cause cancer and birth defects or other reproductive harm. In addition, certain fluids in vehicles and certain components of product wear contain or emit chemicals known to the State of California to cause cancer and birth defects or other reproductive harm.

■ California Perchlorate Advisory

Certain vehicle components such as air-bag modules, seatbelt pretensioners and keyless entry transmitter batteries may contain perchlorate material. Special handling may apply for service or vehicle end of life disposal. See www.dtsc.ca.gov/hazardouswaste/perchlorate.

Table of contents

<i>Seat, seatbelt and SRS airbags</i>	1
<i>Keys and doors</i>	2
<i>Instruments and controls</i>	3
<i>Climate control</i>	4
<i>Audio</i>	5
<i>Interior equipment</i>	6
<i>Starting and operating</i>	7
<i>Driving tips</i>	8
<i>In case of emergency</i>	9
<i>Appearance care</i>	10
<i>Maintenance and service</i>	11
<i>Specifications</i>	12
<i>Consumer information and Reporting safety defects</i>	13
<i>Index</i>	14

Illustrated index

■ Exterior

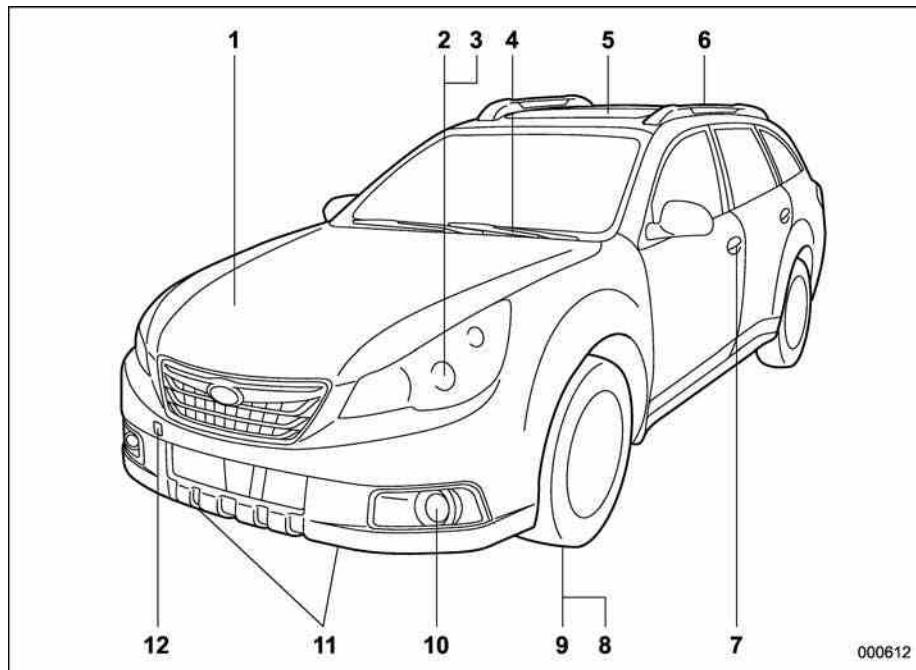

- 1) Engine hood lock release (page 11-7)
- 2) Headlight switch (page 3-27)
- 3) Bulb replacement (page 11-45)
- 4) Wiper switch (page 3-32)
- 5) Moonroof (page 2-27)
- 6) Roof rail (page 8-14)
- 7) Door locks (page 2-4)
- 8) Tire pressure (page 11-32)
- 9) Flat tires (page 9-6)
- 10) Fog light switch (page 3-30)
- 11) Tie-down hooks (page 9-14)
- 12) Towing hook (page 9-13)

000612

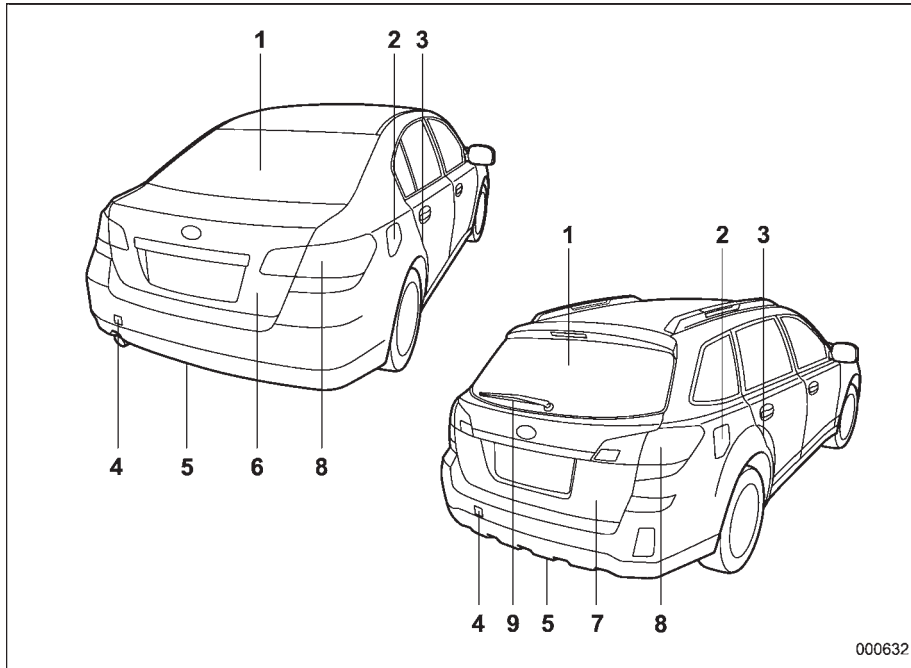

- 1) Rear window defogger button (page 3-34)
- 2) Fuel filler lid and cap (page 7-3)
- 3) Child safety locks (page 2-19)
- 4) Towing hook (page 9-13)
- 5) Tie-down hooks (page 9-14)
- 6) Trunk lid (page 2-23)
- 7) Rear gate (page 2-26)
- 8) Bulb replacement (page 11-49)
- 9) Rear wiper switch (page 3-33)

■ Interior

▼ Passenger compartment area

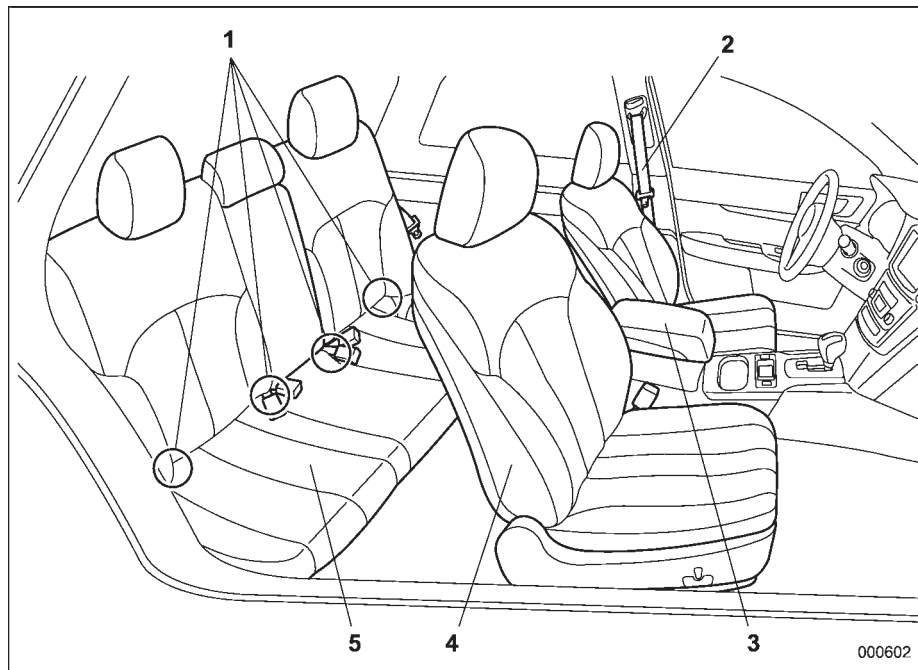

- 1) Lower anchorages for child restraint system (page 1-30)
- 2) Seatbelt (page 1-12)
- 3) Center console (page 6-6)
- 4) Front seat (page 1-2)
- 5) Rear seat (page 1-7)

000602

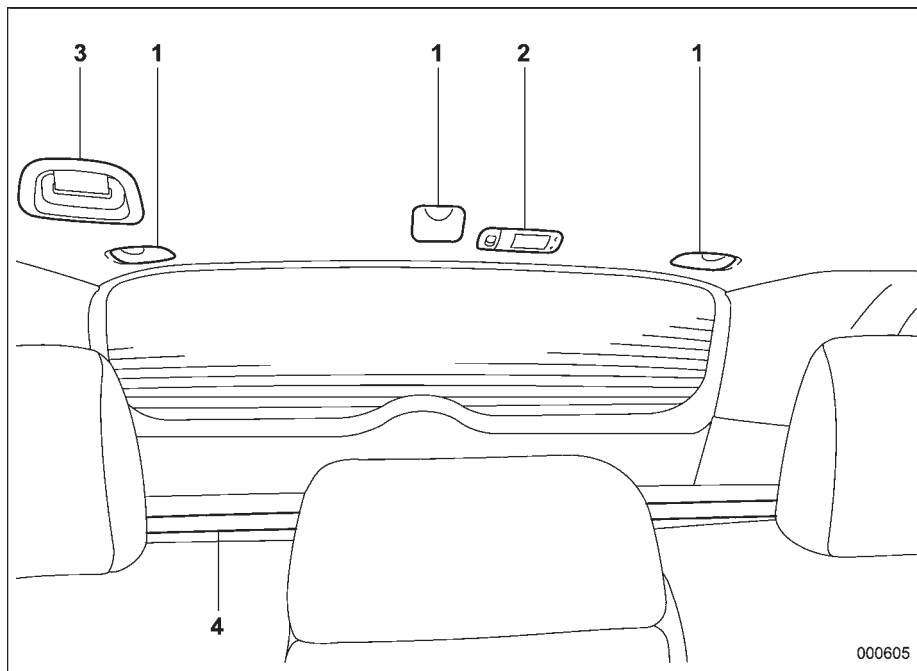

- 1) Top tether anchorages (page 1-33)
- 2) Cargo area light (page 6-3)
- 3) Rear center seatbelt (page 1-17)
- 4) Cargo area cover (page 6-15)

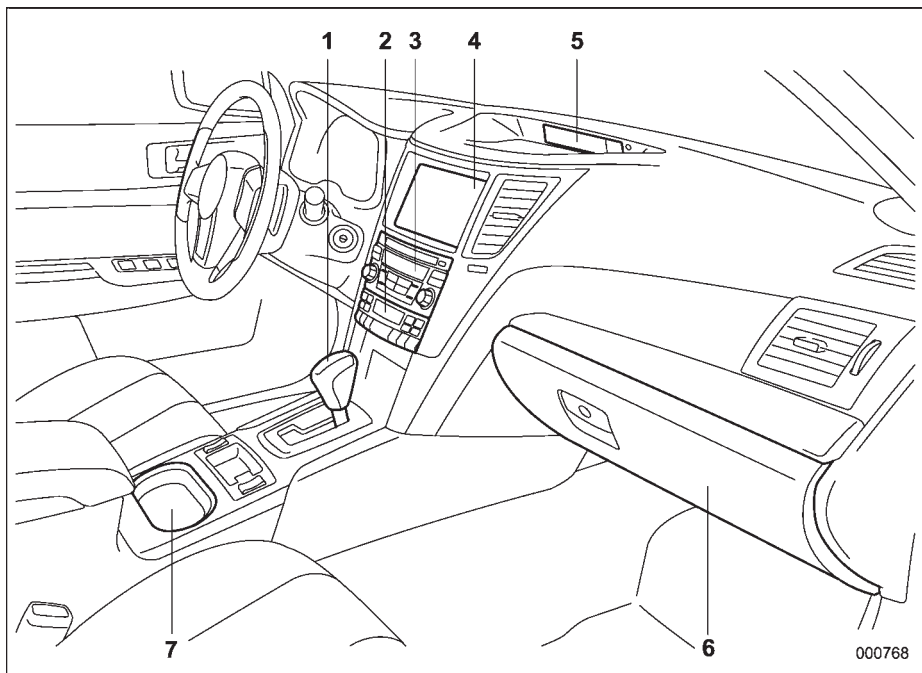

- 1) Shift lever (MT) (page 7-15)/Select lever (AT and CVT) (page 7-18)
- 2) Climate control (page 4-1)
- 3) Audio (page 5-1)
- 4) Navigation system (Refer to the Owner's Manual supplement for the navigation system)
- 5) Multi function display (page 3-24)
- 6) Glove box (page 6-6)
- 7) Cup holder (page 6-8)

000768

■ Instrument panel

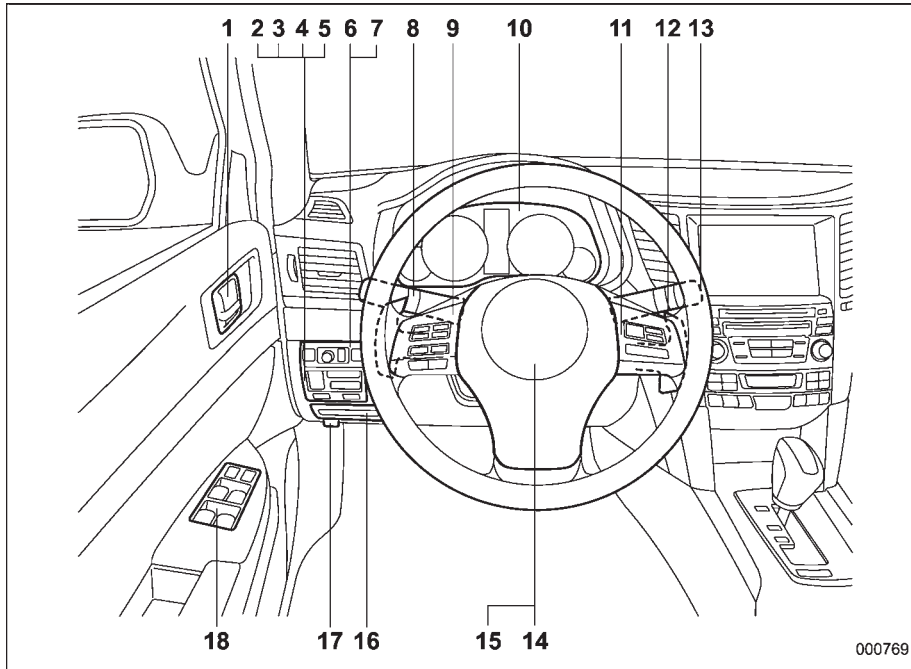

- 1) Door locks (page 2-4)
- 2) Electronic parking brake switch (page 7-31)
- 3) Hill Holder switch (page 7-32)
- 4) Trunk lid opener switch (page 2-24)
- 5) Vehicle Dynamics Control OFF switch (page 7-28)
- 6) Remote control mirror switch (page 3-51)
- 7) Illumination brightness control (page 3-29)
- 8) Light control switch (page 3-27)
- 9) Audio control buttons (page 5-41)
- 10) Combination meter (page 3-5)
- 11) Cruise control (page 7-35)
- 12) Paddle shift (page 7-21)
- 13) Wiper control lever (page 3-30)
- 14) Horn (page 3-52)
- 15) SRS airbag (page 1-36)
- 16) Fuse box (page 11-44)
- 17) Hood lock release knob (page 11-7)
- 18) Power windows (page 2-20)

000769

■ Light control and wiper control levers/switches

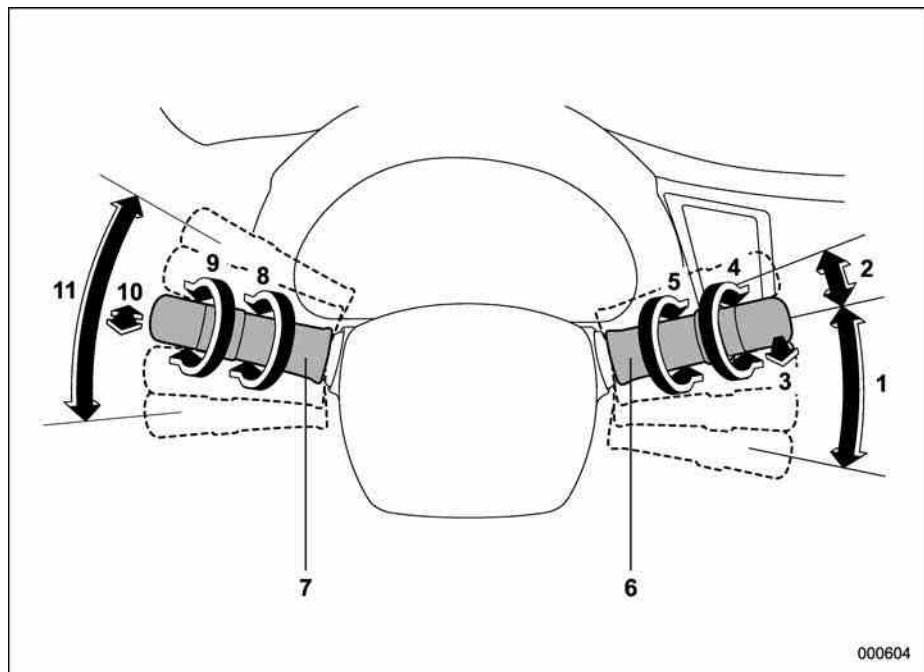

- 1) Windshield wiper (page 3-30)
- 2) Mist (page 3-32)
- 3) Windshield washer (page 3-32)
- 4) Rear window wiper and washer switch (page 3-33)
- 5) Wiper intermittent time control switch (page 3-32)
- 6) Wiper control lever (page 3-32)
- 7) Light control switch (page 3-27)
- 8) Front fog light switch (page 3-30)
- 9) Headlight ON/OFF/AUTO (page 3-27)
- 10) Headlight flasher High/Low beam change (page 3-28)
- 11) Turn signal lever (page 3-29)

■ Combination meter

▼ U.S. spec. models

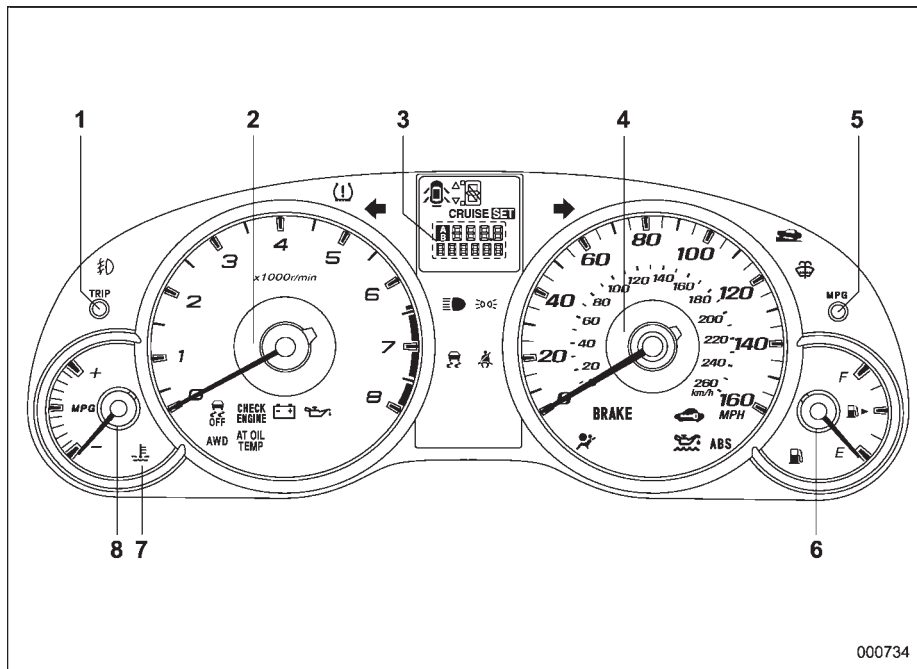

- 1) Trip meter A/B selection and trip meter reset knob (page 3-6)
- 2) Tachometer (page 3-7)
- 3) Trip meter and odometer (page 3-6)
- 4) Speedometer (page 3-6)
- 5) Multi function display switching knob (page 3-24)
- 6) Fuel gauge (page 3-7)
- 7) Coolant temperature warning/indicator light (page 3-13)
- 8) ECO gauge (page 3-8)



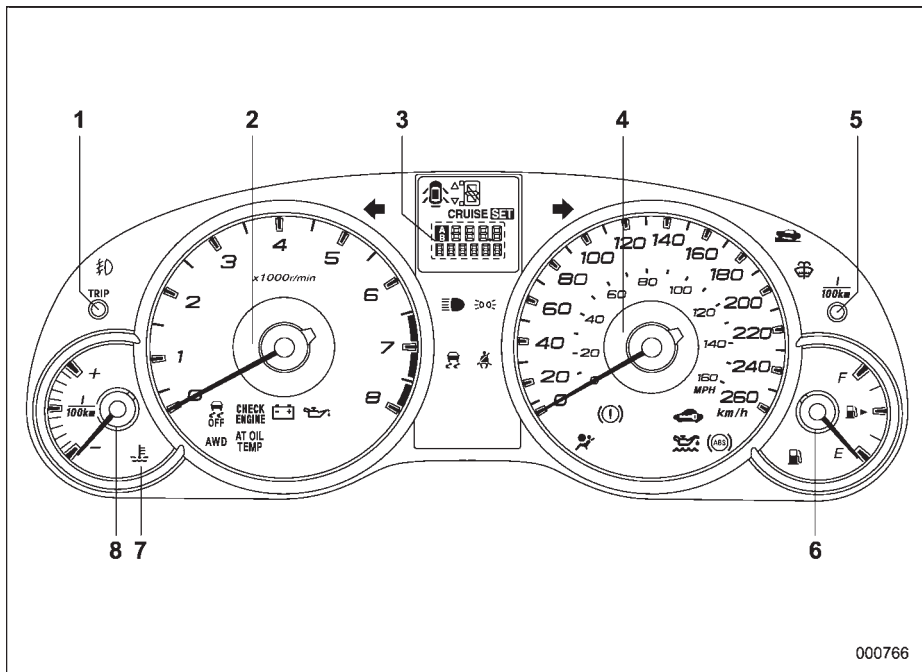





▼ Except U.S. spec. models



















- 1) Trip meter A/B selection and trip meter reset knob (page 3-6)
- 2) Tachometer (page 3-7)
- 3) Trip meter and odometer (page 3-6)
- 4) Speedometer (page 3-6)
- 5) Multi function display switching knob (page 3-24)
- 6) Fuel gauge (page 3-7)
- 7) Coolant temperature warning/indicator light (page 3-13)
- 8) ECO gauge (page 3-8)

000766

■ Warning and indicator lights

Mark	Name	Page
	Seatbelt warning light	3-9
	Front passenger's seatbelt warning light	3-9
	SRS airbag system warning light	3-11
CHECK ENGINE	CHECK ENGINE warning light/Malfunction indicator light	3-12
	Coolant temperature low indicator light/Coolant temperature high warning light	3-13
	Charge warning light	3-14
	Oil pressure warning light	3-14
	Engine oil level warning light	3-14
AT OIL TEMP	AT OIL TEMP warning light (AT and CVT models)	3-14
ABS / 	ABS warning light	3-16

Mark	Name	Page
BRAKE / 	Brake system warning light	3-17
	Hill Holder indicator light	3-19
	Door open indicator light	3-19
	Low fuel warning light	3-19
AWD	All-Wheel Drive warning light (AT and CVT models)	3-20
	Vehicle Dynamics Control warning light/Vehicle Dynamics Control operation indicator light	3-20
	Vehicle Dynamics Control OFF indicator light	3-21
	Security indicator light	3-21
	Turn signal indicator lights	3-22
	High beam indicator light	3-22
	Front fog light indicator light (if equipped)	3-23

Mark	Name	Page
CRUISE	Cruise control indicator light	3-23
	Cruise control set indicator light	3-23
	Headlight indicator light	3-23
	Low tire pressure warning light (U.S. spec. models)	3-15
ON / 	Front passenger's frontal airbag ON indicator light	3-11
OFF / 	Front passenger's frontal airbag OFF indicator light	3-11
	Shift-up indicator	3-22
	Windshield washer fluid warning light	3-19

Function settings

A SUBARU dealer can change the settings of the functions shown in the following table to meet your personal requirements. Contact the nearest SUBARU dealer for details.

Item	Function	Possible settings	Default setting	Page
Alarm system	Alarm system	Operation/Non-operation	Operation	2-15
	Monitoring start delay time (after closure of doors)	0 second/30 seconds	30 seconds	2-17
	Impact sensor operation (only models with shock sensors (dealer option))	Operation/Non-operation	Non-operation	2-19
	Passive arming	Operation/Non-operation	Non-operation	2-18
	Map light/Dome light/Cargo area light illumination	ON/OFF	OFF	2-15
Remote keyless entry system	Hazard warning flasher	Operation/Non-operation	Operation	2-7
	Audible signal	Operation/Non-operation	Operation	2-10
Key lock-in prevention	Key lock-in prevention	Operation/Non-operation	Operation	2-6
Defogger and deicer system for models with the automatic climate control system	Rear window defogger, outside mirror defogger and windshield wiper deicer	Operation for 15 minutes/Continuous operation	Operation for 15 minutes	3-34
Map light/Dome light/Cargo area light	Operation of map light/Dome light/Cargo area light OFF delay timer	OFF/Short/Normal/Long	Long	6-2
Battery drainage prevention function	Battery drainage prevention function	Operation/Non-operation	Operation	2-6
Seatbelt warning	Sounds a chime while driving	Operation/Non-operation	Operation	1-14
Auto on/off headlights	Sensitivity of the operation of the auto on/off headlights	Low/Normal/High/Very high	Normal	3-27

Seat, seatbelt and SRS airbags

Front seats.....	1-2
Manual seat (if equipped)	1-3
Power seat (if equipped).....	1-4
Head restraint adjustment.....	1-6
Seat heater (if equipped)	1-6
Rear seats.....	1-7
Reclining the seatback (Outback).....	1-8
Folding down the rear seatback.....	1-9
Head restraint adjustment.....	1-10
Armrest	1-12
Seatbelts	1-12
Seatbelt safety tips.....	1-12
Emergency Locking Retractor (ELR)	1-13
Automatic/Emergency Locking Retractor (A/ELR)	1-13
Seatbelt warning light and chime	1-14
Fastening the seatbelt	1-14
Seatbelt maintenance	1-20
Front seatbelt pretensioners	1-21
System monitors	1-22
System servicing.....	1-22

Precautions against vehicle modification.....	1-22
Child restraint systems	1-23
Where to place a child restraint system.....	1-24
Choosing a child restraint system	1-25
Installing child restraint systems with A/ELR seatbelt	1-26
Installing a booster seat.....	1-29
Installation of child restraint systems by use of lower and tether anchorages (LATCH)	1-30
Top tether anchorages	1-33
*SRS airbag (Supplemental Restraint System airbag).....	1-36
General precautions regarding SRS airbag system	1-36
Components	1-42
SUBARU advanced frontal airbag system, SRS side airbag and SRS curtain airbag	1-45
System operation.....	1-50
SRS airbag system monitors.....	1-62
SRS airbag system servicing	1-63
Precautions against vehicle modification.....	1-64

Front seats

 **WARNING**

- Never adjust the seat while driving to avoid loss of vehicle control and personal injury.
- Before adjusting the seat, make sure the hands and feet of rear seat passengers or cargo are clear of the adjusting mechanism.
- After adjusting the seat, push it slightly to make sure it is securely locked. If the seat is not securely locked, it may move or the seatbelt may not operate properly.
- Do not put objects under the front seats. They may interfere with front seat locking and cause an accident.
- Seatbelts provide maximum restraint when the occupant sits well back and upright in the seat. To reduce the risk of sliding under the seatbelt in a collision, the front seatbacks should be always used in the upright position while the vehicle is running. If the front seatbacks are not

used in the upright position in a collision, the risk of sliding under the lap belt and of the lap belt sliding up over the abdomen will increase, and both can result in serious internal injury or death.

- The SRS airbags deploy with considerable speed and force. Occupants who are out of proper position when the SRS airbag deploys could suffer very serious injuries. Because the SRS airbag needs enough space for deployment, the driver should always sit upright and well back in the seat as far from the steering wheel as practical while still maintaining full vehicle control and the front passenger should move the seat as far back as possible and sit upright and well back in the seat.



 **WARNING**

Put children in the rear seat properly restrained at all times. The SRS airbag deploys with considerable speed and force and can injure or even kill children, especially if they are not restrained or improperly restrained. Because children are lighter and weaker than adults, their risk of being injured from deployment is greater. Consequently, we strongly recommend that ALL children (including those in child seats and those that have outgrown child restraint devices) sit in the REAR seat properly restrained at all times in a child restraint device or in a seatbelt, whichever is appropriate

for the child's age, height and weight.

Secure ALL types of child restraint devices (including forward facing child seats) in the REAR seats at all times.

NEVER INSTALL A REARWARD FACING CHILD SEAT IN THE FRONT SEAT. DOING SO RISKS SERIOUS INJURY OR DEATH TO THE CHILD BY PLACING THE CHILD'S HEAD TOO CLOSE TO THE SRS AIRBAG.

According to accident statistics, children are safer when properly restrained in the rear seating positions than in the front seating positions. For instructions and precautions concerning child restraint systems, refer to "Child restraint systems" 1-23.

Manual seat (if equipped)

Forward and backward adjustment



Pull the lever upward and slide the seat to the desired position. Then release the lever and try to move the seat back and forth to make sure that it is securely locked into place.

Reclining the seatback

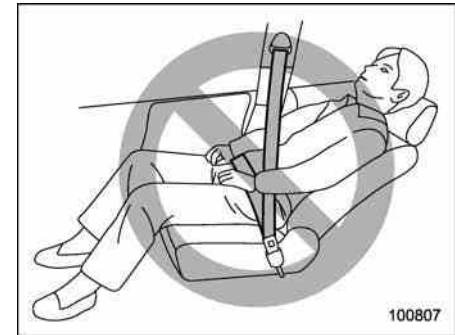

WARNING

To prevent the passenger from sliding under the seatbelt in the event of a collision, always put the seatback in the upright position while the vehicle is in motion. Also, do not place objects such as cushions between the passenger and the seatback. If you do so, the risk of sliding under the lap belt and of the lap belt sliding up over the abdomen will increase, and both can result in serious internal injury or death.

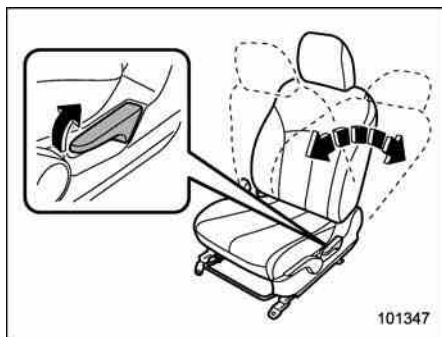

Pull the reclining lever up and adjust the seatback to the desired position. Then release the lever and make sure the seatback is securely locked into place.

The seatback placed in a reclined position can spring back upward with force when the lever is pulled. When operating the reclining lever to return the seatback, hold the seatback lightly so that it may be raised back gradually.

▼ Seat height adjustment (driver's seat)

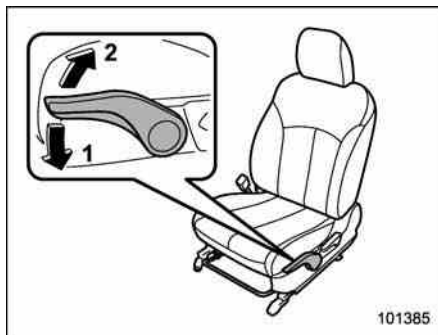

- 1) When the lever is pushed down, the seat is lowered.
- 2) When the lever is pulled up, the seat rises.

The height of the seat can be adjusted by moving the seat cushion adjustment lever up or down.

■ Power seat (if equipped)

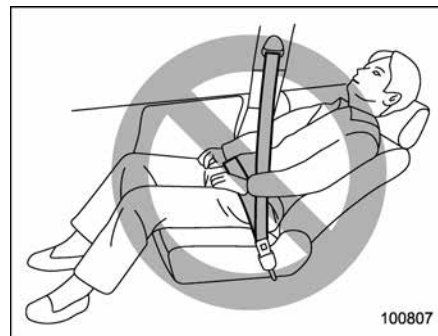

⚠ WARNING

To prevent the passenger from sliding under the seatbelt in the event of a collision, always put the seatback in the upright position while the vehicle is in motion. Also, do not place objects such as cushions between the passenger and the seatback. If you do so, the risk of sliding under the lap belt and of the lap belt sliding up over the abdomen will increase, and both can result in serious internal injury or death.

▼ Driver's seat

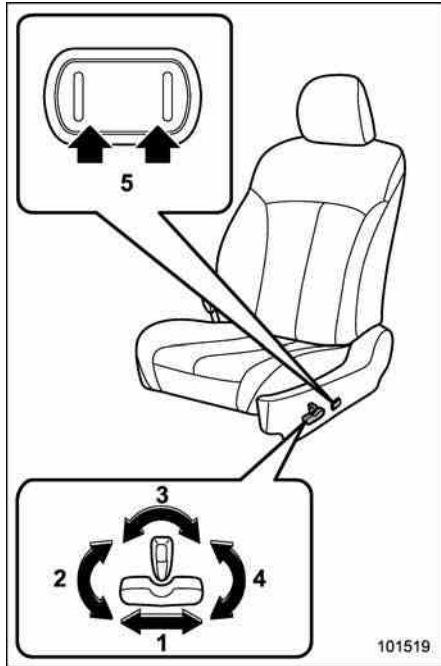
1) **Seat position forward/backward control switch**

To adjust the seat forward or backward, move the control switch forward or backward. During forward/backward adjustment of the seat, you cannot adjust

the seat cushion angle or seat cushion height.

- 2) **Seat cushion angle control switch**
To adjust the seat cushion angle, pull up or push down the front end of the control switch.
- 3) **Seatback angle (reclining) control switch**
To adjust the angle of the seatback, move the control switch.
- 4) **Seat height control switch**
To adjust the seat height, pull up or push down the rear end of the control switch.
- 5) **Lumbar support control switch**
To increase lower back support, push the front side of the switch. To decrease lower back support, push the rear side of the switch.

▼ Front passenger's seat (if equipped)

1) **Seat position forward/backward control switch**

To adjust the seat forward or backward, move the control switch forward or backward.

2) **Seatback angle (reclining) control switch**

To adjust the angle of the seatback, move the control switch.

Head restraint adjustment

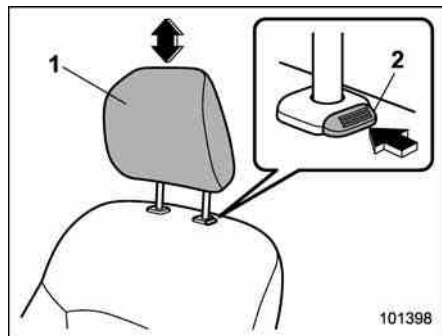

- 1) Head restraint
- 2) Release button

Both the driver's seat and the front passenger's seat are equipped with head restraints.

The head restraint should be adjusted so that the center of the head restraint is closest to the top of the occupant's ears.

To raise:

Pull the head restraint up.

To lower:

Push the head restraint down while pressing the release button on the top of the seatback.

To remove:

While pressing the release button, pull out the head restraint.

To install:

Install the head restraint into the holes that are located on the top of the seatback until the head restraint locks.

WARNING

- Never drive the vehicle with the head restraints removed because they are designed to reduce the risk of serious neck injury in the event that the vehicle is struck from the rear. Therefore, when you remove the head restraints, you must reinstall all head restraints to protect vehicle occupants.
- All occupants, including the driver, should not operate a vehicle or sit in a vehicle's seat until the head restraints are placed in their proper positions in order to minimize the risk of neck injury in the event of a crash.

Seat heater (if equipped)

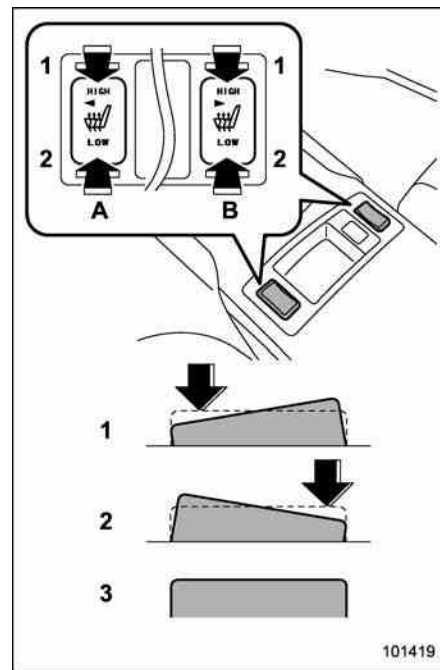

- 1) **HIGH** – Rapid heating
 - 2) **LOW** – Normal heating
 - 3) **OFF** – Off
- A) Left-hand side
B) Right-hand side

The seat heater operates when the ignition switch is either in the "Acc" or "ON" position.

To turn on the seat heater, press the "LOW" or "HIGH" position on the switch, as desired, depending on the temperature.

Selecting the "HIGH" position will cause the seat to heat up quicker.

To turn off the seat heater, slightly press the opposite side of the current position.

The indicator located on the switch illuminates when the seat heater is in operation. When the vehicle's interior is warmed enough or before you leave the vehicle, be sure to turn the switch off.

CAUTION

- There is a possibility that people with delicate skin may suffer slight burns even at low temperatures if they use the seat heater for a long period of time. When using the heater, always be sure to warn the persons concerned.

- Do not put anything on the seat which insulates against heat, such as a blanket, cushion, or similar items. This may cause the seat heater to overheat.

NOTE

Use of the seat heater for a long period of time while the engine is not running can cause battery discharge.

Rear seats



WARNING

Seatbelts provide maximum restraint when the occupant sits well back and upright in the seat. Do not put cushions or any other materials between occupants and seatbacks or seat cushions. If you do so, the risk of sliding under the lap belt and of the lap belt sliding up over the abdomen will increase, and both can result in serious internal injury or death.

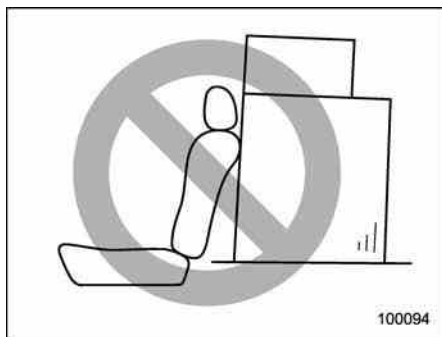

WARNING

Never stack luggage or other cargo higher than the top of the seatback because it could tumble forward and injure passengers in the event of a sudden stop or accident.

Reclining the seatback (Out-back)

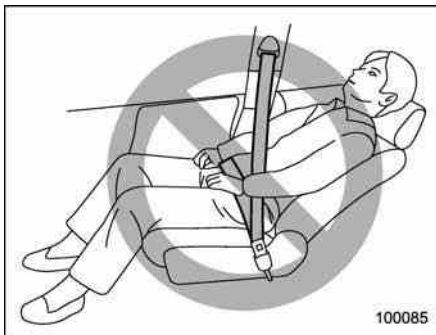

WARNING

To prevent the passenger from sliding under the seatbelt in the event of a collision, always put the seatback in the upright position while the vehicle is in motion.

CAUTION

If the vehicle is equipped with a cargo area cover, observe the following precautions.

- Be careful not to pinch your hand between the headrest and the

cargo area cover when you recline the rear seat.

- Move the front cover of the cargo area cover backward so that the cover is not damaged by the reclined seatback. Refer to “Cargo area cover (Outback – if equipped)” 6-15.

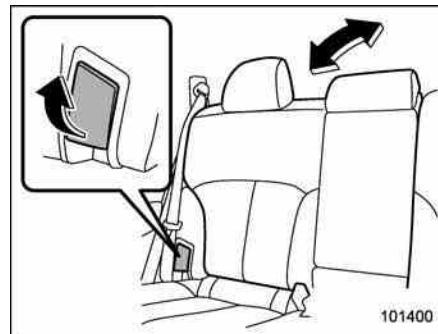

Pull the lever and adjust the seatback to the desired position.

Then release the lever and make sure the seatback is securely locked into place.

■ Folding down the rear seat-back

⚠ WARNING

- When you fold down the seat-back, check that there are no passengers or objects on the rear seat. Not doing so creates a risk of injury or property damage if the seatback suddenly folds down.
- Never allow passengers to ride on the folded rear seatback or in the cargo area or trunk. Doing so may result in serious injury or death.
- Secure all objects and especially long items properly to prevent them from being thrown around inside the vehicle and causing serious injury during a sudden stop, a sudden steering maneuver or a rapid acceleration.
- When you return the seatback to its original position, shake the seatback slightly to confirm that it is securely fixed in place. If the seatback is not securely fixed in place, the seatback may suddenly fold down in the event of sudden braking, or objects may

move out from the cargo area, which could cause serious injury or death.

- After returning the rear seat to its original position, be certain to place all of the seatbelts and the tab attached to the seat cushion above the seat cushion. Also, make certain that the shoulder belts are fully visible.

⚠ CAUTION

The rear seatback may fold down quickly due to the internal spring. Hold the seatback while pulling the release lever to slow it down.

▼ Legacy

To fold down the seatback, perform the following procedure.

1. Open the trunk lid. Refer to “Opening the trunk lid (Legacy)” 2-9 or “To open the trunk lid from inside” 2-24.

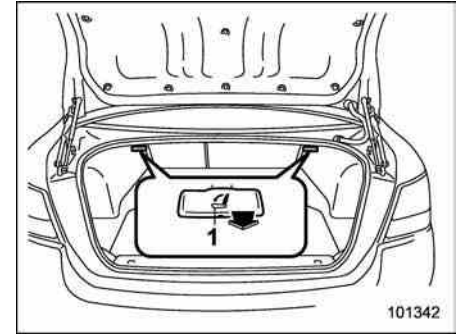

- 1) Release lever
2. Pull the release lever on the side that you want to fold down.
3. Fold the seatback down.

To return the seatback to its original position, raise the seatback until it locks into place and make sure that it is securely locked.

▼ Outback

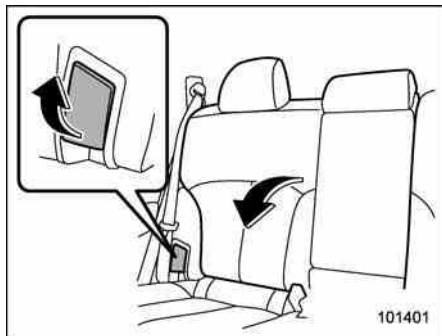

Unlock the seatback by pulling the release lever and then fold the seatback down.

To return the seatback to its original position, raise the seatback until it locks into place and make sure that it is securely locked.

■ Head restraint adjustment

Both the rear window side seats and the rear center seat are equipped with head restraints.

WARNING

- **Never drive the vehicle with the head restraints removed because they are designed to reduce the risk of serious neck injury in the event that the vehicle is struck from the rear. Therefore, when you remove the head restraints, you must reinstall all head restraints to protect vehicle occupants.**
- **All occupants, including the driver, should not operate a vehicle or sit in a vehicle's seat until the head restraints are placed in their proper positions in order to minimize the risk of neck injury in the event of a crash.**

▼ Rear window side seating position

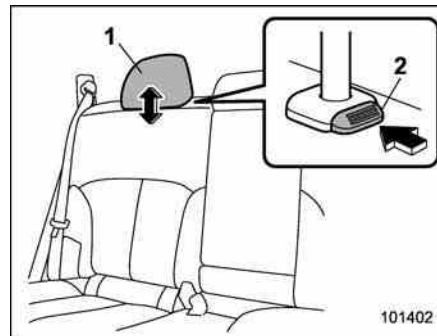

- 1) Head restraint
- 2) Release button

To raise:

Pull the head restraint up.

To lower:

Push the head restraint down while pressing the release button on the top of the seatback.

To remove:

While pressing the release button, pull out the head restraint.

To install:

Install the head restraint into the holes that are located on the top of the seatback until the head restraint locks.

The head restraint should be adjusted so

that the center of the head restraint is closest to the top of the occupant's ears. When the seats are not occupied, lower the head restraints to improve rearward visibility.

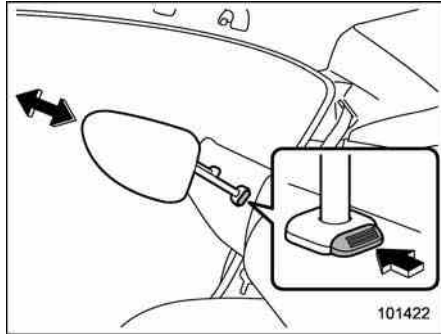

NOTE

For Legacy, it is not possible to remove or install the head restraint without folding down the rear seatback. Fold down the rear seatback and then remove or install the head restraint.

▼ Rear center seating position

⚠ CAUTION

The head restraint is not intended to be used at the lowest position. Before sitting on the seat, raise the head restraint to the extended position.

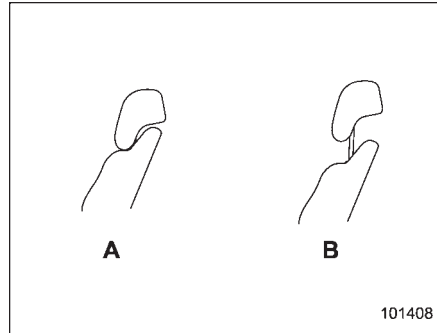

- A) When not used (retracted position)
B) When used (extended position)

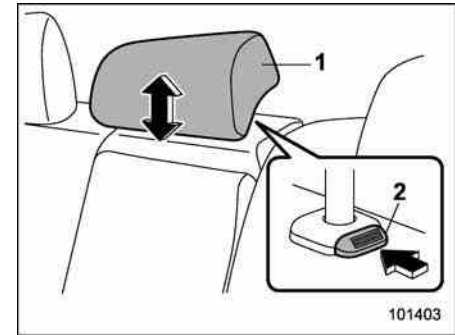

- 1) Head restraint
2) Release button

To raise:

Pull the head restraint up.

To lower:

Push the head restraint down while pressing the release button on the top of the seatback.

To remove:

While pressing the release button, pull out the head restraint.

To install:

Install the head restraint into the holes that are located on the top of the seatback until the head restraint locks.

When the rear-center seating position is occupied, raise the head restraint to the

extended position. When the rear center seating position is not occupied, lower the head restraint to improve rearward visibility.

■ Armrest

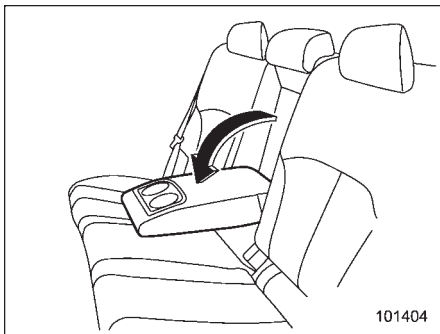

To lower the armrest, pull on the armrest's top edge.

WARNING

To avoid serious injury, passengers must never be allowed to sit on the center armrest while the vehicle is in motion.

Seatbelts

■ Seatbelt safety tips

WARNING

- All persons in the vehicle should fasten their seatbelts **BEFORE** the vehicle starts to move. Otherwise, the possibility of serious injury becomes greater in the event of a sudden stop or accident.
- All belts should fit snugly in order to provide full restraint. Loose fitting belts are not as effective in preventing or reducing injury.
- Each seatbelt is designed to support only one person. Never use a single belt for two or more persons – even children. Otherwise, in an accident, serious injury or death could result.
- Replace all seatbelt assemblies including retractors and attaching hardware worn by occupants of a vehicle that has been in a serious accident. The entire assembly should be replaced even if damage is not obvious.

- Put children in the rear seat properly restrained at all times. The SRS airbag deploys with considerable speed and force and can injure or even kill children, especially if they are not restrained or improperly restrained. Because children are lighter and weaker than adults, their risk of being injured from deployment is greater. Consequently, we strongly recommend that **ALL** children (including those in child seats and those that have outgrown child restraint devices) sit in the **REAR** seat properly restrained at all times in a child restraint device or in a seatbelt, whichever is appropriate for the child's height and weight.

Secure **ALL** types of child restraint devices (including forward facing child seats) in the **REAR** seats at all times.

NEVER INSTALL A REARWARD FACING CHILD SEAT IN THE FRONT SEAT. DOING SO RISKS SERIOUS INJURY OR DEATH TO THE CHILD BY PLACING THE CHILD'S HEAD TOO CLOSE TO THE SRS AIRBAG.

According to accident statistics, children are safer when properly restrained in the rear seating positions than in the front seating positions. For instructions and precautions concerning the child restraint system, refer to “Child restraint systems” 1-23.

Your vehicle is equipped with a crash sensing and diagnostic module, which will record the use of the seatbelt by the front passenger when any of the SRS frontal, side and curtain airbags deploys.

▼ Infants or small children

Use a child restraint system that is suitable for your vehicle. Refer to “Child restraint systems” 1-23.

▼ Children

If a child is too big for a child restraint system, the child should sit in the rear seat and be restrained using the seatbelts. According to accident statistics, children are safer when properly restrained in the rear seating positions than in the front seating positions. Never allow a child to stand up or kneel on the seat.

If the shoulder portion of the belt crosses the face or neck, move the child closer to the belt buckle to help provide a good

shoulder belt fit. Care must be taken to securely place the lap belt as low as possible on the hips and not on the child’s waist. If the shoulder portion of the belt cannot be properly positioned, a child restraint system should be used. Never place the shoulder belt under the child’s arm or behind the child’s back.

▼ Expectant mothers

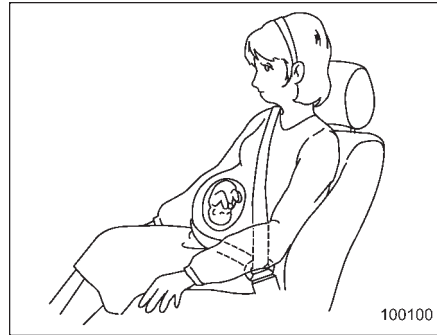

Expectant mothers also need to use the seatbelts. They should consult their doctor for specific recommendations. The lap belt should be worn securely and as low as possible over the hips, not over the waist.

■ Emergency Locking Retractor (ELR)

The driver’s seatbelt has an Emergency Locking Retractor (ELR).

The emergency locking retractor allows normal body movement but the retractor locks automatically during a sudden stop, impact or if you pull the belt very quickly out of the retractor.

■ Automatic/Emergency Locking Retractor (A/ELR)

Each passenger’s seatbelt has an Automatic/Emergency Locking Retractor (A/ELR). The Automatic/Emergency Locking Retractor normally functions as an Emergency Locking Retractor (ELR). The A/ELR has an additional locking mode, “Automatic Locking Retractor (ALR) mode”, intended to secure a child restraint system.

The ALR mode functions as follows.

When the seatbelt is once drawn out completely and is then retracted even slightly, the retractor locks the seatbelt in that position and the seatbelt cannot be extended. As the belt is rewinding, clicks will be heard which indicate the retractor functions as an ALR. When the seatbelt is retracted fully, the ALR mode is canceled and the ELR mode is restored.

1-14 Seat, seatbelt and SRS airbags

When securing a child restraint system on the rear seats by using a seatbelt, the seatbelt must be changed over to the Automatic Locking Retractor (ALR) mode. For instructions on how to install the child restraint system using a seatbelt, refer to "Installing child restraint systems with A/ELR seatbelt" 1-26.

When the child restraint system is removed, make sure that the retractor is restored to the Emergency Locking Retractor (ELR) mode by allowing the seatbelt to retract fully.

■ Seatbelt warning light and chime



Refer to "Seatbelt warning light and chime" 3-9.

■ Fastening the seatbelt

WARNING

- Never use a belt that is twisted or reversed. In an accident, this can increase the risk or severity of injury.
- Keep the lap belt as low as possible on your hips. In a collision, this spreads the force of the lap belt over stronger hip bones

instead of across the weaker abdomen.

- Seatbelts provide maximum restraint when the occupant sits well back and upright in the seat. To reduce the risk of sliding under the seatbelt in a collision, the front seatbacks should be always used in the upright position while the vehicle is running. If the front seatbacks are not used in the upright position in a collision, the risk of sliding under the lap belt and of the lap belt sliding up over the abdomen will increase, and both can result in serious internal injury or death.
- Do not put cushions or any other materials between occupants and seatbacks or seat cushions. If you do so, the risk of sliding under the lap belt and of the lap belt sliding up over the abdomen will increase, and both can result in serious internal injury or death.

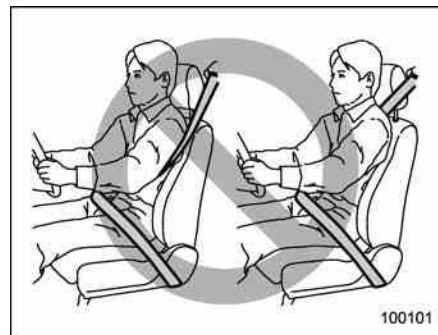

WARNING

Never place the shoulder belt under the arm or behind the back. If an accident occurs, this can increase the risk or severity of injury.

CAUTION

Metallic parts of the seatbelt can become very hot in a vehicle that has been closed up in sunny weather; they could burn an occupant. Do not touch such hot parts until they cool.

▼ Front seatbelts

1. Adjust the seat position:

Driver's seat: Adjust the seatback to the upright position. Move the seat as far from the steering wheel as practical while still maintaining full vehicle control.

Front passenger's seat: Adjust the seatback to the upright position. Move the seat as far back as possible.

2. Sit well back in the seat.

3. Pick up the tongue plate and pull the belt out slowly. Do not let it get twisted. If the belt stops before reaching the buckle, return the belt slightly and pull it out more slowly. If the belt still cannot be unlocked, let the belt retract slightly after giving it a strong pull, then pull it out slowly again.

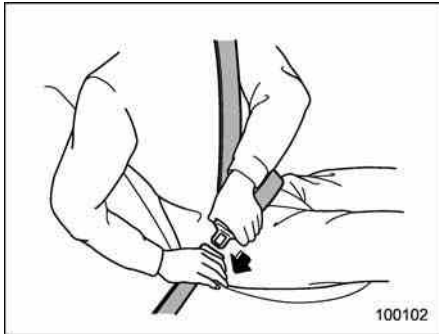

4. Insert the tongue plate into the buckle

until you hear a click.

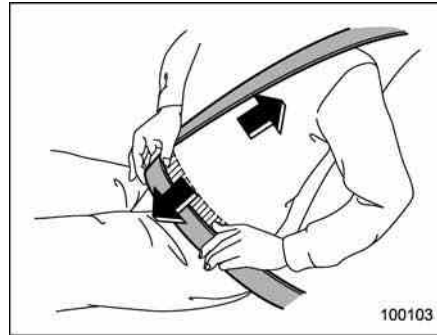

5. To make the lap part tight, pull up on the shoulder belt.
6. Place the lap belt as low as possible on your hips, not on your waist.

▽ Adjusting the front seat shoulder belt anchor height

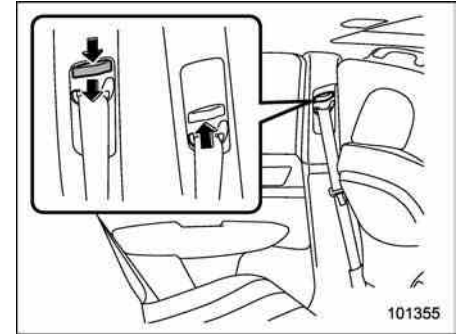

The shoulder belt anchor height should be adjusted to the position best suited for the driver/front passenger. Always adjust the anchor height so that the shoulder belt passes over the middle of the shoulder without touching the neck.

To raise:

Slide the anchor up.

To lower:

Push the release button and slide the anchor down.

Pull down the anchor to make sure that it is locked in place.

WARNING

When wearing the seatbelts, make sure the shoulder portion of the webbing does not pass over your neck. If it does, adjust the seatbelt anchor to a lower position. Placing the shoulder belt over the neck may result in neck injury during sudden braking or in a collision.

▽ Unfastening the seatbelt

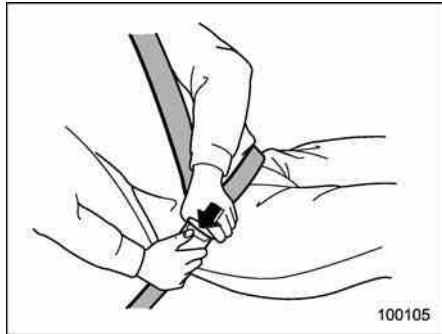

Push the button on the buckle.

Before closing the door, make sure that the belts are retracted properly to avoid catching the belt webbing in the door.

▼ Rear seatbelts (except rear center seatbelt on Outback)

1. Sit well back in the seat.
2. Pick up the tongue plate and pull the belt out slowly. Do not let it get twisted. If the belt stops before reaching the buckle, return the belt slightly and pull it out more slowly. If the belt still cannot be unlocked, let the belt retract slightly after giving a strong pull on it, then pull it out slowly again.

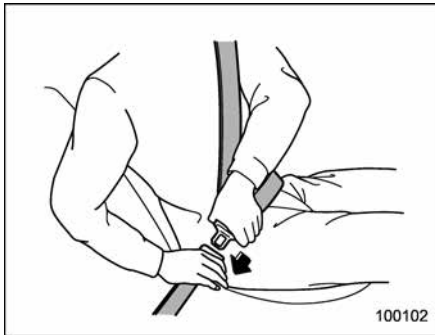

3. Insert the tongue plate into the buckle until you hear a click.

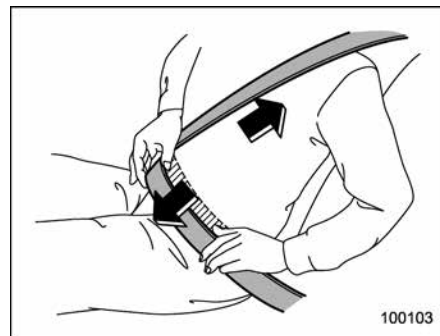

4. To make the lap part tight, pull up on the shoulder belt.
5. Place the lap belt as low as possible on your hips, not on your waist.

▽ Unfastening the seatbelt

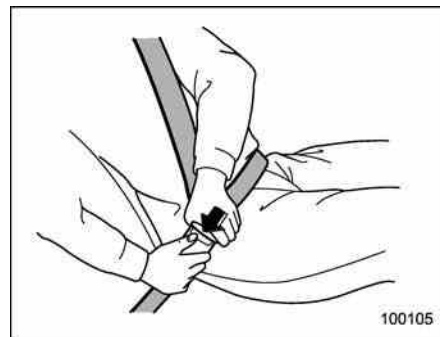

Push the button on the buckle.

Before closing the door, make sure that the belts are retracted properly to avoid catching the belt webbing in the door.

▼ **Rear center seatbelt on Outback**

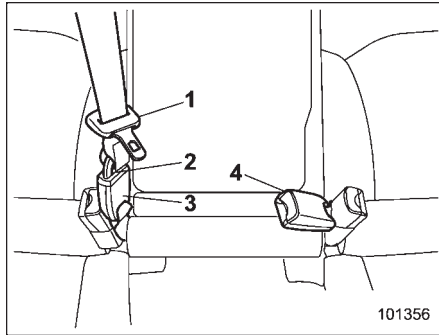

- 1) Center seatbelt tongue plate
- 2) Connector (tongue)
- 3) Connector (buckle)
- 4) Center seatbelt buckle

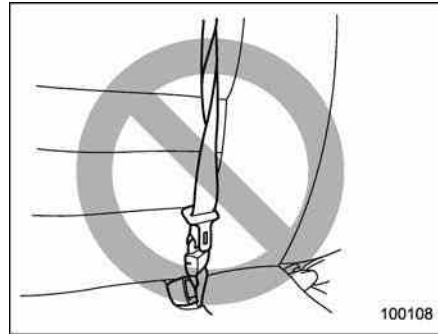

WARNING

Fastening the seatbelt with the webbing twisted can increase the risk or severity of injury in an accident. When fastening the belt after it is pulled out from the retractor, especially when inserting the connector's tongue plate into the mating buckle (on right-hand side), always check that the webbing is not twisted.

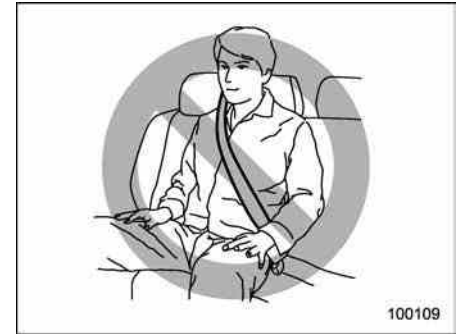

WARNING

Be sure to fasten both tongue plates to the respective buckles. If the seatbelt is used only as a shoulder belt (with the connector's tongue plate not fastened to the connector's buckle on the right-hand side), it cannot properly restrain the wearer in position in an accident, possibly resulting in serious injury or death.

1-18 Seat, seatbelt and SRS airbags

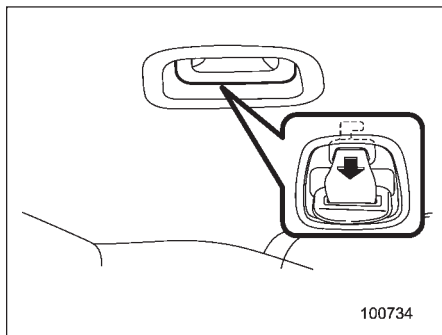

Rear center seatbelt is stowed in the recess of the ceiling.

1. Retrieve the connector (tongue) plate from the slot in the recess by pulling the connector (tongue) plate.

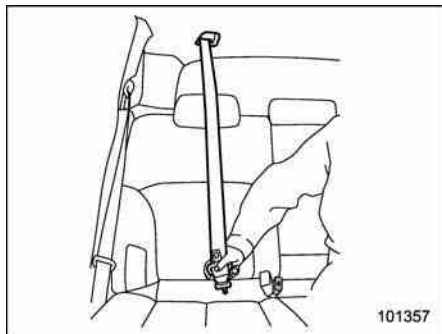

2. Pull out the seatbelt slowly from the retractor.

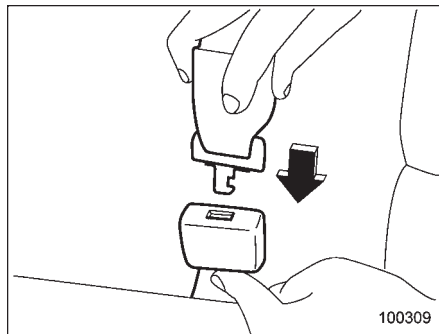

3. After confirming that the webbing is not twisted, insert the connector (tongue) attached at the webbing end into the buckle on the right-hand side until a click is heard. If the belt stops before reaching the buckle, return the belt slightly and pull it out more slowly. If the belt still cannot be unlocked, let the belt retract slightly after giving it a strong pull, then pull it out slowly again.

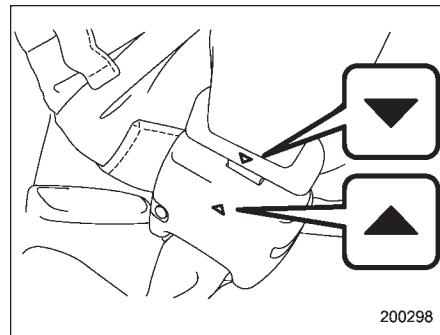

4. After fastening the seatbelt, make sure that the “▼” mark on the connector (tongue) and the “▲” mark on the buckle face outwards.



5. Insert the center seatbelt tongue plate into the center seatbelt buckle marked

“CENTER” on the left-hand side until it clicks.

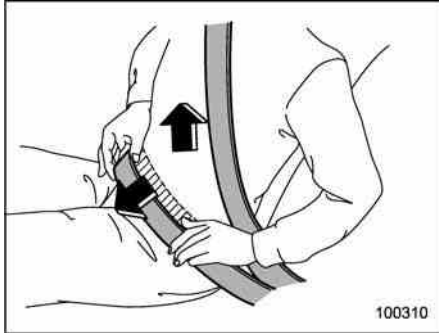

6. To make the lap part tight, pull up on the shoulder belt. And place the lap belt as low as possible on your hips, not on your waist.

▽ Unfastening the seatbelt

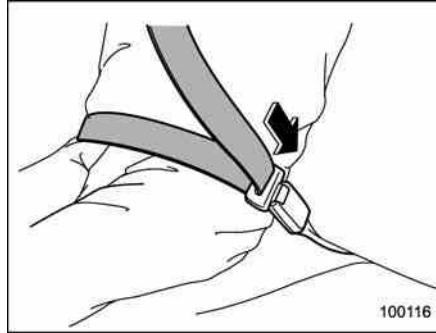

Push the release button of the center seatbelt buckle (on the left-hand side) to unfasten the seatbelt.

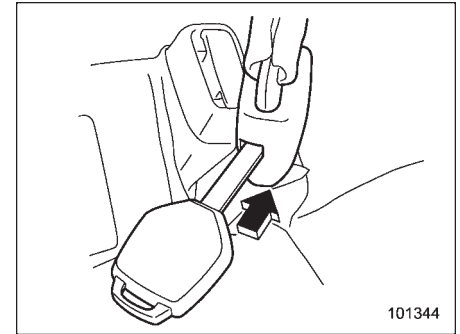

1. Insert a key or other hard pointed object into the slot in the connector (buckle) on the right-hand side and push it in, and the connector (tongue) plate will disconnect from the buckle.

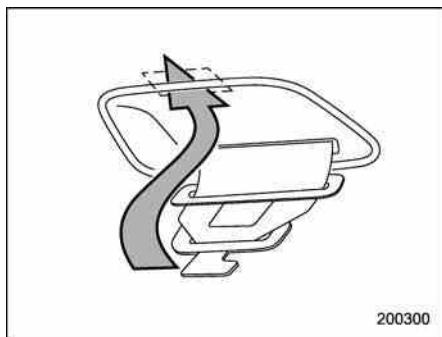

2. Allow the retractor to roll up the belt. You should hold the webbing end and guide it back into the retractor while it is rolling up. Neatly store the tongue plate in the recess and then insert the connector (tongue) plate into the slot.

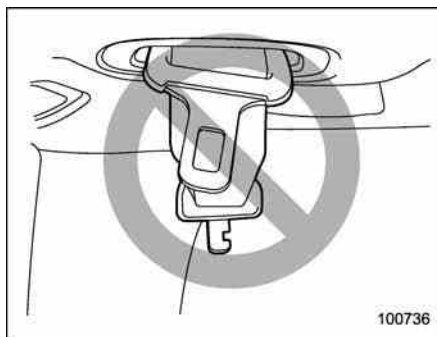

CAUTION

- Do not allow the retractor to roll up the seatbelt too quickly. Otherwise, the metal tongue plates may hit against the trim, resulting in damaged trim.
- Have the seatbelt fully rolled up so that the tongue plates are neatly stored. A hanging tongue plate can swing and hit against the trim during driving, causing damage to the trim.

■ Seatbelt maintenance

To clean the seatbelts, use a mild soap and lukewarm water. Never bleach or dye the belts because this could seriously affect their strength.

Inspect the seatbelts and attachments including the webbing and all hardware periodically for cracks, cuts, gashes, tears, damage, loose bolts or worn areas. Replace the seatbelts even if only minor damage is found.



CAUTION

- Keep the belts free of polishes, oils, chemicals and particularly battery acid.
- Never attempt to make modifications or changes that will prevent the seatbelt from operating properly.

Front seatbelt pretensioners

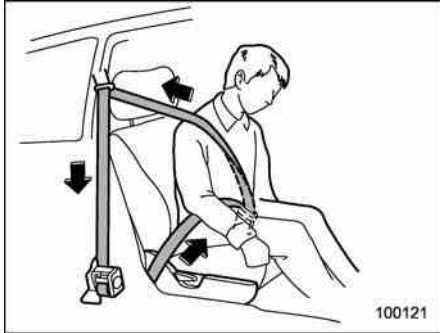

The driver's and front passenger's seatbelts have a seatbelt pretensioner. The seatbelt pretensioners are designed to be activated in the event of an accident involving a moderate to severe frontal collision.

The pretensioner sensor also serves as a SRS frontal airbag sensor. If the sensor detects a certain predetermined amount of force during a frontal collision, the front seatbelt is quickly drawn back in by the retractor to take up the slack so that the belt more effectively restrains the front seat occupant.

When a seatbelt pretensioner is activated, an operating noise will be heard and a

small amount of smoke will be released. These occurrences are normal and not harmful. This smoke does not indicate a fire in the vehicle.

Once the seatbelt pretensioner has been activated, the seatbelt retractor remains locked. Consequently, the seatbelt cannot be pulled out and retracted and therefore must be replaced.

NOTE

- Seatbelt pretensioners are not designed to activate in minor frontal impacts, in side or rear impacts or in roll-over accidents.
- The driver's seat and passenger's seat pretensioners and frontal airbag operate simultaneously.
- Pretensioners are designed to function on a one-time-only basis. In the event that a pretensioner is activated, both the driver's and front passenger's seatbelt retractor assemblies must be replaced and only by an authorized SUBARU dealer. When replacing seatbelt retractor assemblies, use only genuine SUBARU parts.
- If either front seatbelt does not retract or cannot be pulled out due to a malfunction or activation of the pretensioner, contact your SUBARU dealer as soon as possible.

- If the front seatbelt retractor assembly or surrounding area has been damaged, contact your SUBARU dealer as soon as possible.
- When you sell your vehicle, we urge you to explain to the buyer that it has seatbelt pretensioners by alerting the buyer to the contents of this section.



WARNING

- To obtain maximum protection, occupants should sit in an upright position with their seatbelts properly fastened. Refer to "Seatbelts" 1-12.
- Do not modify, remove or strike the front seatbelt retractor assemblies or surrounding area. This could result in accidental activation of the seatbelt pretensioners or could make the system inoperative, possibly resulting in serious injury. Seatbelt pretensioners have no user-serviceable parts. For required servicing of front seatbelt retractors equipped with seatbelt pretensioners, see your nearest SUBARU dealer.
- When discarding front seatbelt retractor assemblies or scrap-

ping the entire vehicle due to collision damage or for other reasons, consult your SUBARU dealer.

■ System monitors

A diagnostic system continually monitors the readiness of the seatbelt pretensioner while the vehicle is being driven. The seatbelt pretensioners share the control module with the airbag system. Therefore, if any malfunction occurs in a seatbelt pretensioner, the SRS airbag system warning light will illuminate. For details, refer to "SRS airbag system monitors" 1-62.

■ System servicing

WARNING

- When discarding a seatbelt retractor assembly or scrapping the entire vehicle damaged by a collision, consult your SUBARU dealer.
- Tampering with or disconnecting the system's wiring could result in accidental activation of the seatbelt pretensioner and/or airbag or could make the system

inoperative, which may result in serious injury. Do not use electrical test equipment on any circuit related to the seatbelt pretensioner and airbag systems. For required servicing of the seatbelt pretensioner, consult your nearest SUBARU dealer.

CAUTION

The front sub sensors are located in both front fenders and the airbag control module including the impact sensors is located under the center console. If you need service or repair in those areas or near the front seatbelt retractors, have the work performed by your authorized SUBARU dealer.

NOTE

If the front part of the vehicle is damaged in an accident to the extent that the seatbelt pretensioner does not operate, contact your SUBARU dealer as soon as possible.

■ Precautions against vehicle modification

Always consult your SUBARU dealer if you want to install any accessory parts to your vehicle.

CAUTION

Do not perform any of the following modifications. Such modifications can interfere with proper operation of the seatbelt pretensioners.

- Attachment of any equipment (bush bar, winches, snow plow, skid plate, etc.) other than genuine SUBARU accessory parts to the front end.
- Modification of the suspension system or front end structure.
- Installation of a tire of different size and construction from the tires specified on the vehicle placard attached to the door pillar or specified for individual vehicle models in this Owner's Manual.

Child restraint systems

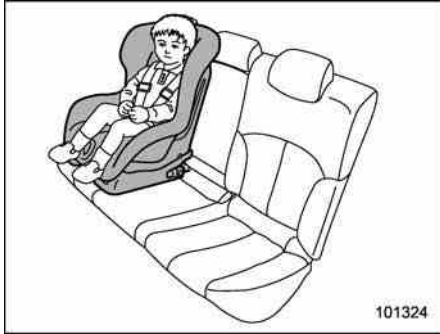

Infants and small children should always be placed in an infant or child restraint system in the rear seat while riding in the vehicle.

You should use an infant or child restraint system that meets Federal Motor Vehicle Safety Standards or Canada Motor Vehicle Safety Standards, is compatible with your vehicle and is appropriate for the child's age and size.

All child restraint systems are designed to be secured in vehicle seats by lap belts or the lap belt portion of a lap/shoulder belt (except those covered under the section in this manual, entitled "Installation of child restraint systems by use of lower and

tether anchorages (LATCH)" 1-30).

Children could be endangered in an accident if their child restraints are not properly secured in the vehicle. When installing the child restraint system, carefully follow the manufacturer's instructions.

According to accident statistics, children are safer when properly restrained in the rear seating positions than in the front seating positions.

All U.S. states and Canadian provinces require that infants and small children be restrained in an approved child restraint system at all times while the vehicle is moving.

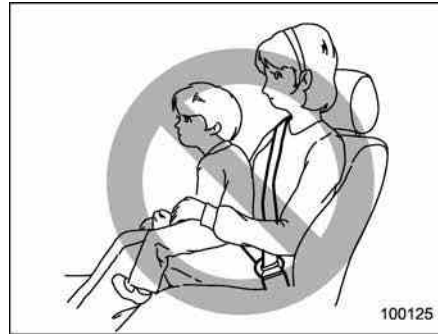

⚠ WARNING

Never let a passenger hold a child on his or her lap while the vehicle is moving. The passenger cannot protect the child from injury in a collision, because the child will be caught between the passenger and objects inside the vehicle. Additionally, holding a child in your lap or arms in the front seat exposes that child to another serious danger. Since the SRS airbag deploys with considerable speed and force, the child could be injured or even killed.

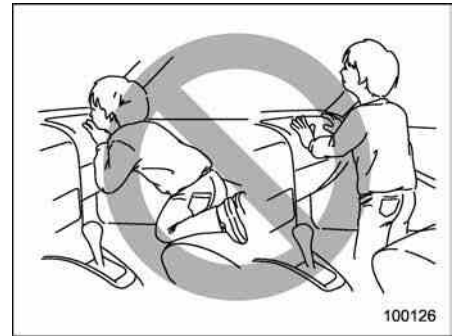



WARNING

Children should be properly restrained at all times. Never allow a child to stand up, or to kneel on any seat. Unrestrained children will be thrown forward during sudden stop or in an accident and can be injured seriously.

Additionally, children standing up or kneeling on or in front of the front seat are exposed another serious danger. Since the SRS airbag deploys with considerable speed and force, the child could be injured or even killed.

■ **Where to place a child restraint system**

The following descriptions are SUBARU's recommendations on where to place a child restraint system in your vehicle.

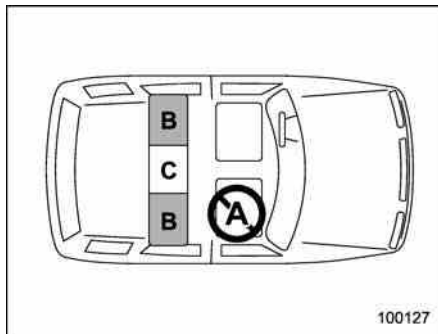

A: Front passenger's seat

You should not install a child restraint system (including a booster seat) due to the hazard to children posed by the passenger's airbag.

B: Rear seat, window-side seating positions

Recommended positions for all types of child restraint systems.

In these positions, Automatic/Emergency Locking Retractor (A/ELR) seatbelts and lower anchorages (bars) are provided for

installing a child restraint system.

Some types of child restraints might not be able to be secured firmly due to projection of the seat cushion.

In this seating position, you should use only a child restraint system that has a bottom base that fits snugly against the contours of the seat cushion and can be securely retained using the seatbelt.

C: Rear seat, center seating position

Installing a child restraint system is not recommended, although the A/ELR seatbelt and an upper anchorage (tether anchorage) are provided in this position. Some types of child restraints might not be able to be secured firmly due to projection of the seat cushion.

In this seating position, you should use only a child restraint system that has a bottom base that fits snugly against the contours of the seat cushion and can be securely retained using the seatbelt.

! WARNING

Put children in the rear seat properly restrained at all times. The SRS airbag deploys with considerable speed and force and can injure or even kill children, especially if they are not restrained or improperly restrained. Because children are lighter and weaker than adults, their risk of being injured from deployment is greater.

For that reason, be sure to secure ALL types of child restraint devices (including forward facing child seats) in the REAR seats at all times. You should choose a restraint device which is appropriate for the child's age, height and weight. According to accident statistics, children are safer when properly restrained in the rear seating positions than in the front seating positions.

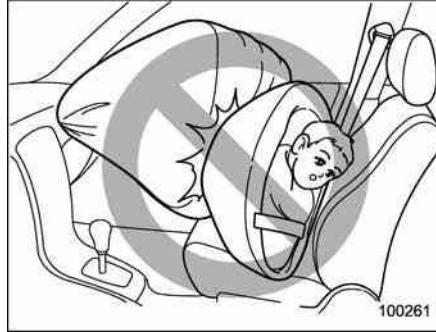
**! WARNING**

SINCE YOUR VEHICLE IS EQUIPPED WITH A PASSENGER'S SRS AIRBAG, DO NOT INSTALL A REARWARD FACING CHILD SAFETY SEAT IN THE FRONT PASSENGER'S SEAT. DOING SO RISKS SERIOUS INJURY OR DEATH TO THE CHILD BY PLACING THE CHILD'S HEAD TOO CLOSE TO THE SRS AIRBAG.

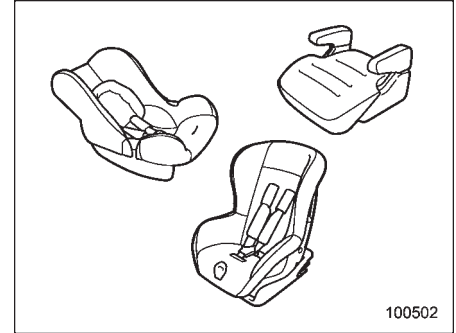
■ Choosing a child restraint system

Choose a child restraint system that is appropriate for the child's age and size (weight and height) in order to provide the child with proper protection. The child restraint system should meet all applicable requirements of Federal Motor Vehicle Safety Standards for United States or Canada Motor Vehicle Safety Standards for Canada. It can be identified by looking for the label on the child restraint system or the manufacturer's statement of compliance in the document attached to the system. Also it is important for you to make sure that the child restraint system is compatible with the vehicle in which it will be used.

■ Installing child restraint systems with A/ELR seatbelt

⚠ WARNING

- Child restraint systems and seatbelts can become hot in a vehicle that has been closed up in sunny weather; they could burn a small child. Check the child restraint system before you place a child in it.
- Do not leave an unsecured child restraint system in your vehicle. Unsecured child restraint systems can be thrown around inside of the vehicle in a sudden stop, turn or accident; they can strike and injure vehicle occupants as well as result in serious injuries or death to the child.

⚠ CAUTION

When you install a child restraint system, follow the manufacturer's instructions supplied with it. After installing the child restraint system, check to ensure that it is held securely in position. If it is not held tight and secure, the danger of your child suffering personal injury in the event of an accident may be increased.

▼ Installing a rearward facing child restraint

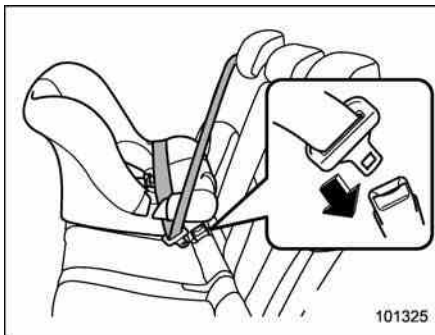

1. Place the child restraint system in the rear seating position.
2. Run the lap and shoulder belt through

or around the child restraint system following the instructions provided by its manufacturer.

3. Insert the tongue plate into the buckle until you hear a click.

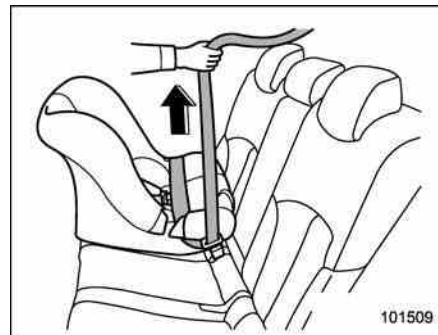

4. Take up the slack in the lap belt.
5. Pull out the seatbelt fully from the retractor to change the retractor over from the Emergency Locking Retractor (ELR) to the Automatic Locking Retractor (ALR) function. Then, allow the belt to rewind into the retractor. As the belt is rewinding, clicks will be heard which indicate the retractor functions as ALR.

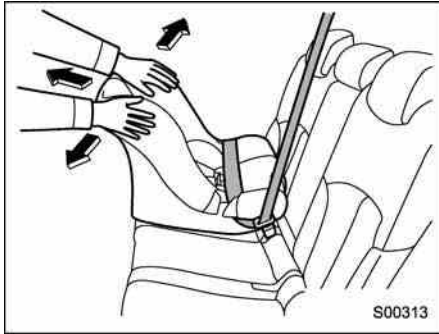

6. Push and pull the child restraint system forward and side to side to check that it is firmly secured in the center of the seat.

Sometimes a child restraint can be more firmly secured by pushing it down into the seat cushion and then tightening the seatbelt.

7. Pull at the shoulder portion of the belt to confirm that it cannot be pulled out (ALR properly functioning).

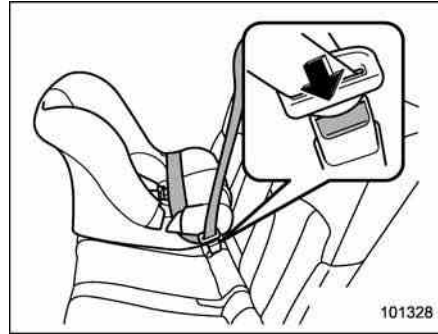

8. To remove the child restraint system, press the release button on the seatbelt buckle and allow the belt to retract completely. The belt will return to the ELR mode.

⚠ WARNING

NEVER INSTALL A REARWARD FACING CHILD SEAT IN THE FRONT PASSENGER'S SEAT. DOING SO RISKS SERIOUS INJURY OR DEATH TO THE CHILD BY PLACING THE CHILD'S HEAD TOO CLOSE TO THE SRS AIRBAG.

NOTE

When the child restraint system is no longer in use, remove it and restore the ELR function of the retractor. That function is restored by retracting the seatbelt fully.

▼ Installing forward facing child restraint

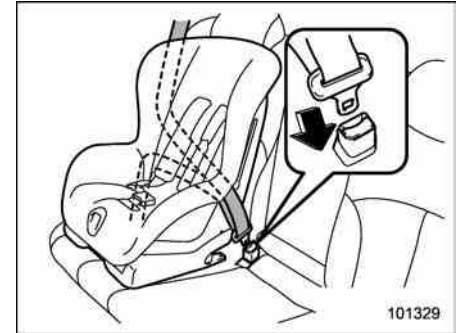

1. Place the child restraint system in the rear seating position.
2. Run the lap and shoulder belt through or around the child restraint system following the instructions provided by its manufacturer.
3. Insert the tongue plate into the buckle until you hear a click.

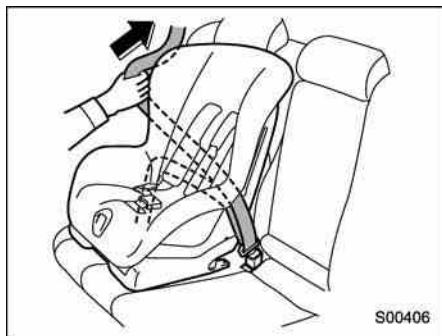

4. Take up the slack in the lap belt.
5. Pull out the seatbelt fully from the retractor to change the retractor over from the Emergency Locking Retractor (ELR) to the Automatic Locking Retractor (ALR) function. Then, allow the belt to rewind into the retractor. As the belt is rewinding, clicks will be heard which indicate the retractor functions as ALR.

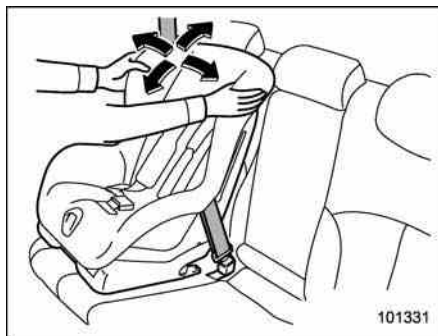

6. Before seating a child in the child restraint system, try to move it back and forth and left and right to verify that it is firmly secured in the center of the seat. Sometimes a child restraint can be more firmly secured by pushing it down into the seat cushion and then tightening the seatbelt.
7. Pull at the shoulder portion of the belt to confirm that it cannot be pulled out (ALR properly functioning).

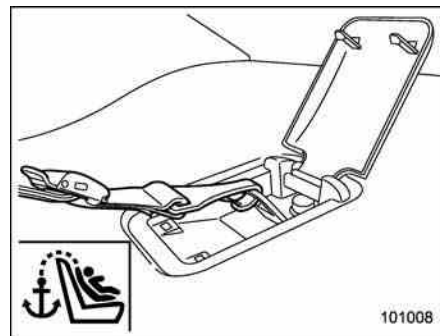

Legacy

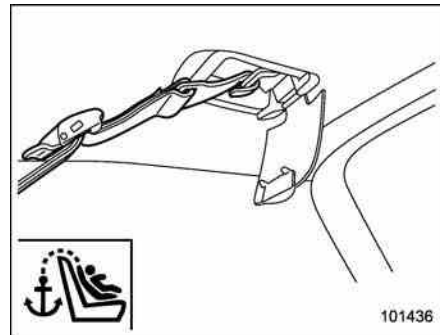

Outback

8. If the child restraint system requires a top tether, latch the hook onto the top tether anchor and tighten the top tether. For additional instructions, refer to "Top

tether anchorages" 1-33.

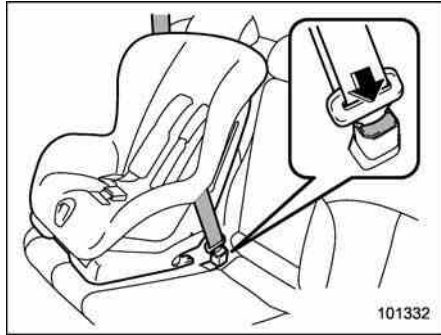

9. To remove the child restraint system, press the release button on the seatbelt buckle and allow the belt to retract completely. The belt will return to the ELR mode.

NOTE

When the child restraint system is no longer in use, remove it and restore the ELR function of the retractor. That function is restored by allowing the seatbelt to retract fully.

■ Installing a booster seat

⚠ WARNING

- Child restraint systems and seatbelts can become hot in a vehicle that has been closed up in sunny weather; they could burn a small child. Check the child restraint system before you place a child in it.
- Do not leave an unsecured child restraint system in your vehicle. Unsecured child restraint systems can be thrown around inside of the vehicle in a sudden stop, turn or accident; they can strike and injure vehicle occupants as well as result in serious injuries or death to the child.

⚠ CAUTION

When you install a child restraint system, follow the manufacturer's instructions supplied with it. After installing the child restraint system, check to ensure that it is held securely in position. If it is not held tight and secure, the danger of your child suffering personal injury in the event of an accident may be increased.



1. Place the booster seat in the rear seating position and sit the child on it. The child should sit well back on the booster seat.
2. Run the lap and shoulder belt through or around the booster seat and the child

following the instructions provided by its manufacturer.

3. Insert the tongue plate into the buckle until you hear a click. Take care not to twist the seatbelt.

Make sure the shoulder belt is positioned across the center of child's shoulder and that the lap belt is positioned as low as possible on the child's hips.

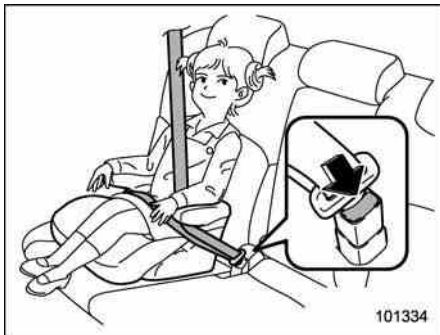

4. To remove the booster seat, press the release button on the seatbelt buckle and allow the belt to retract.

WARNING

- Never use a belt that is twisted or reversed. In an accident, this can increase the risk or severity of injury to the child.

- Never place the shoulder belt under the child's arm or behind the child's back. If an accident occurs, this can increase the risk or severity of injury to the child.
- The seatbelt should fit snugly in order to provide full restraint. Loose fitting belts are not as effective in preventing or reducing injury.
- Place the lap belt as low as possible on the child's hips. A high-positioned lap belt will increase the risk of sliding under the lap belt and of the lap belt sliding up over the abdomen, and both can result in serious internal injury or death.
- Make sure the shoulder belt is positioned across the center of child's shoulder. Placing the shoulder belt over the neck may result in neck injury during sudden braking or in a collision.

Installation of child restraint systems by use of lower and tether anchorages (LATCH)

WARNING

- Child restraint systems and seatbelts can become hot in a vehicle that has been closed up in sunny weather; they could burn a small child. Check the child restraint system before you place a child in it.
- Do not leave an unsecured child restraint system in your vehicle. Unsecured child restraint systems can be thrown around inside of the vehicle in a sudden stop, turn or accident; they can strike and injure vehicle occupants as well as result in serious injuries or death to the child.

CAUTION

When you install a child restraint system, follow the manufacturer's instructions supplied with it. After installing the child restraint system, check to ensure that it is held securely in position. If it is not held

tight and secure, the danger of your child suffering personal injury in the event of an accident may be increased.

Some types of child restraint systems can be installed on the rear seat of your vehicle without use of the seatbelts. Such child restraint systems are secured to the dedicated anchorages provided on the vehicle body.

The lower and tether anchorages are sometimes referred to as the LATCH system (**L**ower **A**nchors and **T**ethers for **C**hildren).



101210

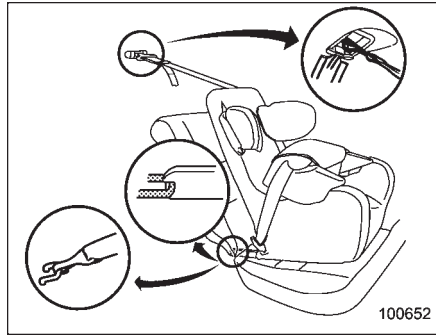

Your vehicle is equipped with four lower anchorages (bars) and three upper anchorages (tether anchorages) for accommodating such child restraint systems.

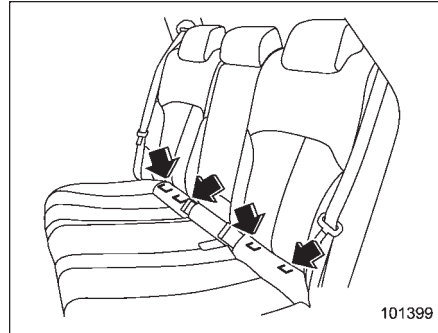

The lower anchorages (bars) are used for installing a child restraint system only on

the rear seat window-side seating positions. For each window-side seating position, two lower anchorages are provided. Each lower anchorage is located behind the cover of seatback bottom.

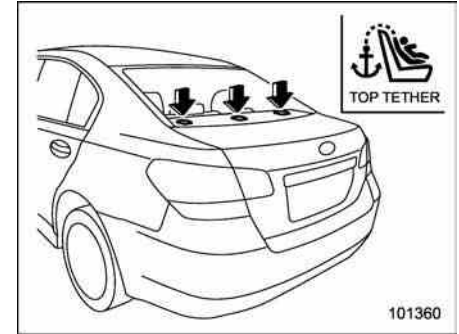

Legacy

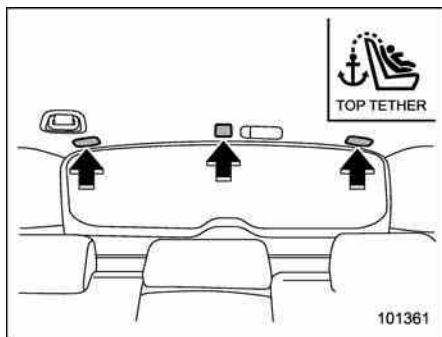

Outback

The tether anchorages (upper anchorages) are provided for all the seating positions (center and both window-side ones) of the rear seat.

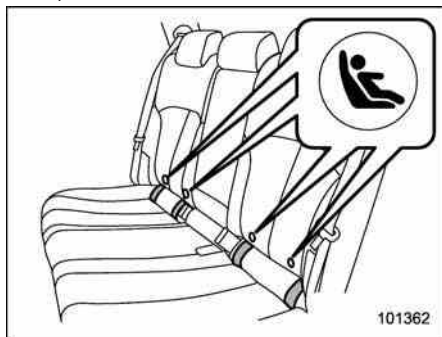

You will find marks "Ⓜ" at the bottom of the

rear seat seatbacks. These marks indicate the positions of the lower anchorages (bars).

Each lower anchorage is located behind the cover of seatback bottom.

⚠ CAUTION

When you install a child restraint system, follow the manufacturer's instructions supplied with it. After installing the child restraint system, check to ensure that it is held tightly and secure. If it is not held tightly and secure, the danger of your child suffering personal injury in the event of an accident may be increased.

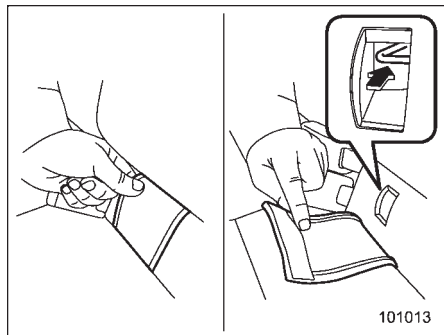

Peel off the anchorage cover from the

selected side of the rear seatback to expose the anchorages (bars) to be used for installation of the child restraint system.

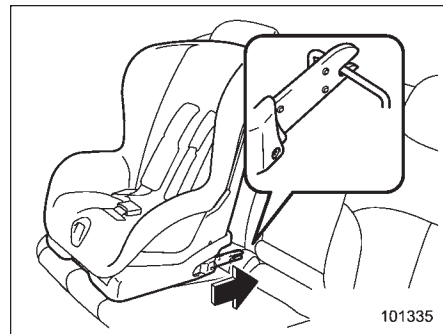

1. While following the instructions supplied by the child restraint system manufacturer, connect the lower hooks onto the lower anchorages located at "Ⓜ" marks on the bottom of the rear seatback. When the hooks are connected, make sure the adjacent seatbelts are not caught.

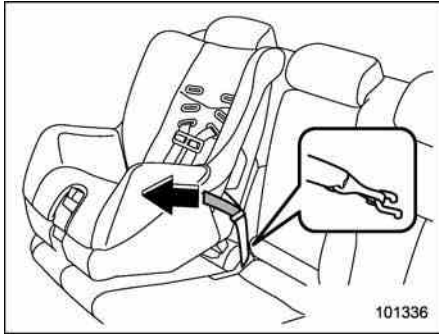

2. If your child restraint system is of a flexible attachment type (which uses tether belts to connect the child restraint system properly to the lower anchorages), while pushing the child restraint into the seat cushion, pull both left and right lower tether belts up to secure the child restraint system firmly by taking up the slack in the belt.

3. Connect the top tether hook to the tether anchorage and firmly tighten the tether. For information on how to set the top tether, refer to "Top tether anchorages" 1-33.



4. Before seating a child in the child restraint system, try to move it back and forth and left and right to verify that it is firmly secured in the center of the seat.

5. To remove the child restraint system, follow the reverse procedures of installation.

If you have any question concerning this type of child restraint system, ask your SUBARU dealer.

■ Top tether anchorages

Your vehicle is equipped with three top tether anchorages so that a child restraint system having a top tether can be installed in the rear seat. When installing a child restraint system using top tether, proceed as follows, while observing the

instructions by the child restraint system manufacturer.

Since a top tether can provide additional stability by offering another connection between a child restraint system and the vehicle, we recommend that you use a top tether whenever one is required or available.

▼ Tether anchorage location

▽ Legacy

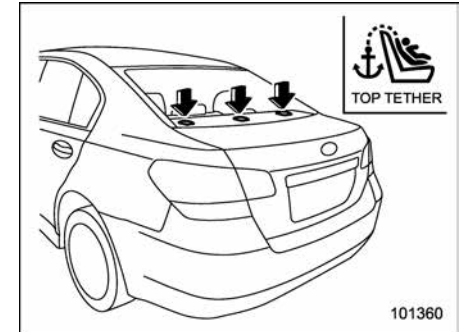

Three tether anchorages are installed on the rear shelf behind the rear seat head restraint. Open the cover flap to use each anchorage.

▽ Outback

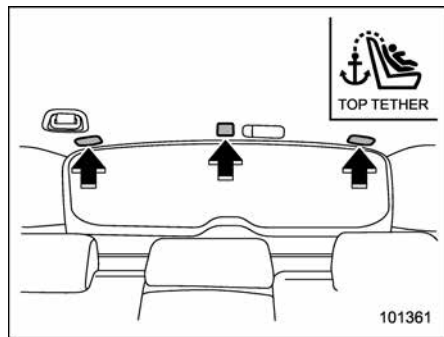

Three tether anchorages, i.e., ones for the right, center and left positions, are already installed on the rear edge of the roof. Open the cover flap to use each anchorage.

▼ To hook the top tether

CAUTION

Always remove the head restraint when mounting a child restraint system with a top tether. Failure to do so may prevent the top tether from being fastened tightly.

▽ Legacy

1. Fold down the rear seatback for the window side seating position. Refer to "Folding down the rear seatback" 1-9.

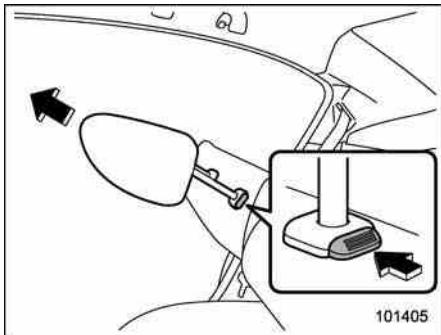

2. Remove the head restraint at the seating position where the child restraint system has been installed with the seatbelt or lower anchorages; lift up the head

restraint while pressing the release button. Store the head restraint in the trunk. Avoid placing the head restraint in the passenger compartment to prevent it from being thrown around in the passenger compartment in a sudden stop or a sharp turn.

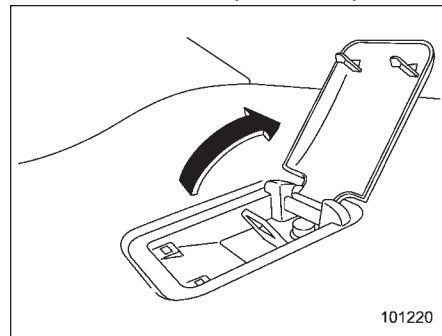

3. Open the cover flaps to use the anchorages.

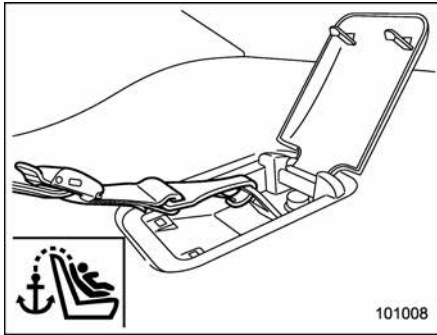

4. Fasten the top tether hook of the child restraint system to the appropriate upper anchorage.
5. Tighten the top tether securely.

▽ Outback

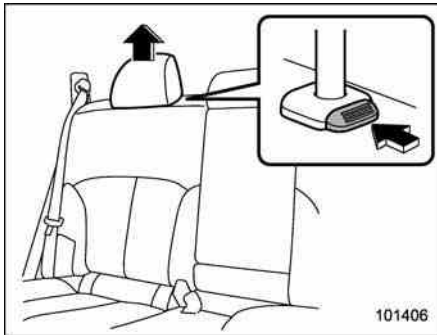

1. Remove the head restraint at the seating position where the child restraint system has been installed with the seatbelt or lower anchorages; lift up the head restraint while pressing the release button. Store the head restraint in the cargo area. Avoid placing the head restraint in the passenger compartment to prevent it from being thrown around in the passenger compartment in a sudden stop or a sharp turn.

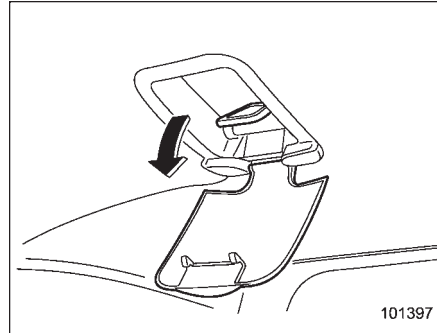

2. Open the cover flaps to use the anchorages.

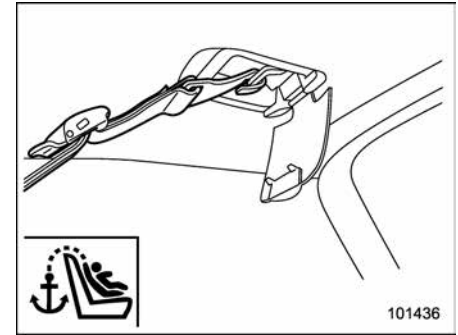

3. Fasten the top tether hook of the child restraint system to the appropriate upper anchorage.
4. Tighten the top tether securely.

*SRS airbag (Supplemental Restraint System airbag)

*SRS: This stands for supplemental restraint system. This name is used because the airbag system supplements the vehicle's seatbelts.

Your vehicle is equipped with a crash sensing and diagnostic module, which will record the use of the seatbelt by the front passenger when any of the SRS frontal, side and curtain airbags deploys.

Your vehicle is equipped with a supplemental restraint system in addition to a lap/shoulder belt at each front seating position and each rear window-side seating position. The supplemental restraint system (SRS) consists of six airbags.

The configurations are as follows:

- Driver's and front passenger's **frontal** airbags
- Driver's and front passenger's **side** airbags
- **Curtain** airbags (for driver, front passenger, and window-side rear passengers)

These SRS airbags are designed only as a supplement to the primary protection provided by the seatbelt.

The system also controls front seatbelt pretensioners. For operation instructions and precautions concerning the seatbelt pretensioner, refer to "Front seatbelt pretensioners" 1-21.

■ General precautions regarding SRS airbag system



WARNING

- To obtain maximum protection in the event of an accident, the driver and all passengers in the vehicle should always wear seatbelts when the vehicle is moving. The SRS airbag is designed only to be a supplement to the primary protection provided by the seatbelt. It does not eliminate the need to fasten seatbelts. In combination with the seatbelts, it offers the best combined protection in case of a serious accident.

Not wearing a seatbelt increases the chance of severe injury or death in a crash even when the vehicle has the SRS airbag.

For instructions and precautions concerning the seatbelt system, refer to "Seatbelts" 1-12.

- The SRS side airbag and SRS

curtain airbag are designed only to be a supplement to the primary protection provided by the seatbelt. They do not eliminate the need to fasten seatbelts. It is also important to wear your seatbelt to help avoid injuries that can result when an occupant is not seated in a proper upright position.



100155



WARNING

- The SRS airbags deploy with considerable speed and force. Occupants who are out of proper position when the SRS airbag deploys could suffer very serious injuries. Because the SRS airbag

needs enough space for deployment, the driver should always sit upright and well back in the seat as far from the steering wheel as practical while still maintaining full vehicle control and the front passenger should move the seat as far back as possible and sit upright and well back in the seat.



▲ WARNING

- Do not sit or lean unnecessarily close to either front door. The SRS side airbags are stored in both front seat seatbacks next to the door, and they provide protection by deploying rapidly (fas-

ter than the blink of an eye) in the event of a side impact collision. However, the force of SRS side airbag deployment may cause injuries if your head or other parts of the body are too close to the SRS side airbag.

- Since your vehicle is equipped with SRS curtain airbags, do not sit or lean unnecessarily close to the front or rear door on either side. Also, do not put your head, arms or hands out of the window. The SRS curtain airbags on both sides of the cabin are stored in the roof side (between the front pillar and a point over the rear seat), and they provide protection by deploying rapidly (faster than the blink of an eye) in the event of a side impact. For Out-back models, the SRS curtain airbags also deploy in the event of a rollover. However, the force of its deployment may cause injuries if your head is too close to it.
- Do not sit or lean unnecessarily close to the SRS airbag. Because the SRS airbag deploys with considerable speed – faster than the blink of an eye – and force to

protect in high speed collisions, the force of an airbag can injure an occupant whose body is too close to SRS airbag.

It is also important to wear your seatbelt to help avoid injuries that can result when the SRS airbag contacts an occupant not in proper position such as one thrown forward during pre-accident braking.

Even when properly positioned, there remains a possibility that an occupant may suffer minor injury such as abrasions and bruises to the face or arms because of the SRS airbag deployment force.



⚠ WARNING

- Do not rest your arm on either front door or its internal trim. You could be injured in the event of SRS side airbag deployment.
- Do not place any objects over or near the SRS airbag cover or between you and the SRS airbag. If the SRS airbag deploys, these objects could interfere with its proper operation and could be propelled inside the vehicle, causing injury.

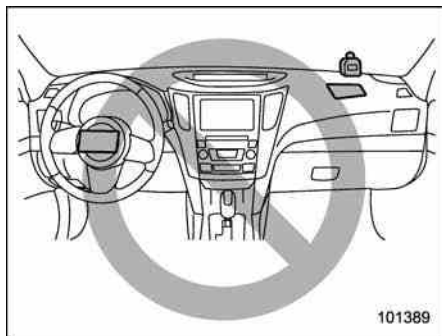

⚠ WARNING

Do not put any objects over the

steering wheel pad and dashboard. If the SRS frontal airbag deploys, these objects could interfere with its proper operation and could be propelled inside the vehicle, causing injury.

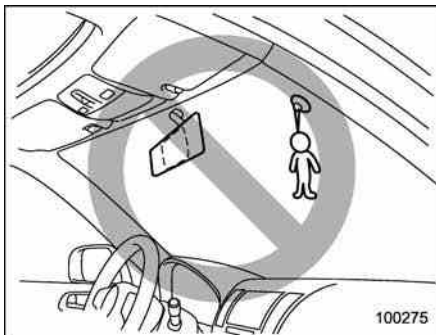

⚠ WARNING

Do not attach accessories to the windshield, or fit an extra-wide mirror over the rear view mirror. If the SRS airbag deploys, those objects could become projectiles that could seriously injure vehicle occupants.

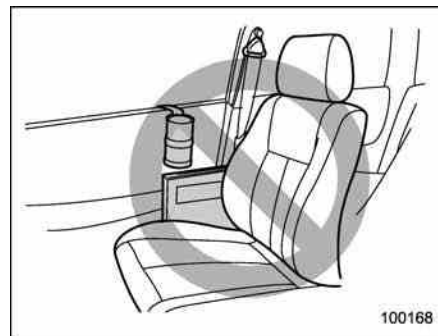

⚠ WARNING

- Do not attach accessories to the door trim or near either SRS side airbags and do not place objects near the SRS side airbags. In the event of SRS side airbag deployment, they could be propelled dangerously toward the vehicle's occupants and cause injuries.
- Do not attach a hands-free microphone or any other accessory to a front pillar, a center pillar, a rear pillar, the windshield, a side window, an assist grip, or any other cabin surface that would be near a deploying SRS curtain airbag. A hands-free microphone or

other accessory in such a location could be propelled through the cabin with great force by the curtain airbag, or it could prevent correct deployment of the curtain airbag. In either case, the result could be serious injuries.

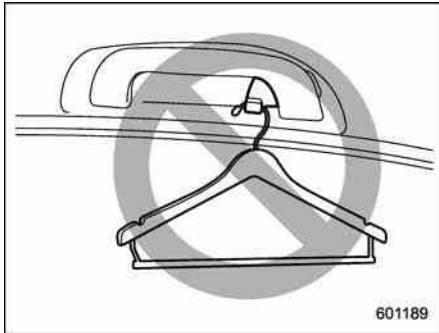

601189

⚠ WARNING

Do not hang coat hangers or other hard or pointed objects on the coat hooks. If such items were hanging on the coat hooks during deployment of the SRS curtain airbags, they could cause serious injuries by coming off the coat hooks and being thrown through the cabin or by preventing deployment of the cur-

tain airbags.

Before hanging clothing on the coat hooks, make sure there are no sharp objects in the pockets. Hang clothing directly on the coat hooks without using hangers.

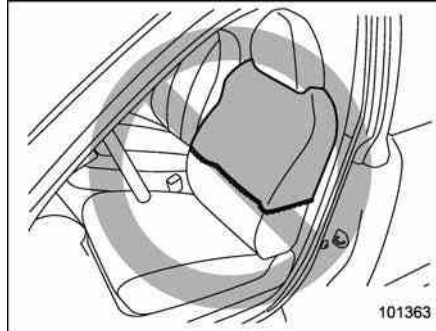

101363

⚠ WARNING

Do not put any kind of cover or clothes or other objects over either front seatback and do not attach labels or stickers to the front seat surface on or near the SRS side airbag. They could prevent proper deployment of the SRS side airbag, reducing protection available to the front seat's occupant.



100082

⚠ WARNING

Put children in the rear seat properly restrained at all times. The SRS airbag deploys with considerable speed and force and can injure or even kill children, especially if they are not restrained or improperly restrained. Because children are lighter and weaker than adults, their risk of being injured from deployment is greater.

Consequently, we strongly recommend that ALL children (including those in child seats and those that have outgrown child restraint devices) sit in the REAR seat properly restrained at all times in a child

restraint device or in a seatbelt, whichever is appropriate for the child's age, height and weight.

Secure ALL types of child restraint devices (including forward facing child seats) in the REAR seats at all times.

According to accident statistics, children are safer when properly restrained in the rear seating positions than in the front seating positions.

For instructions and precautions concerning the child restraint system, refer to "Child restraint systems" 1-23.



⚠ WARNING

NEVER INSTALL A REARWARD FACING CHILD SEAT IN THE FRONT SEAT. DOING SO RISKS SERIOUS INJURY OR DEATH TO THE CHILD BY PLACING THE CHILD'S HEAD TOO CLOSE TO THE SRS AIRBAG.

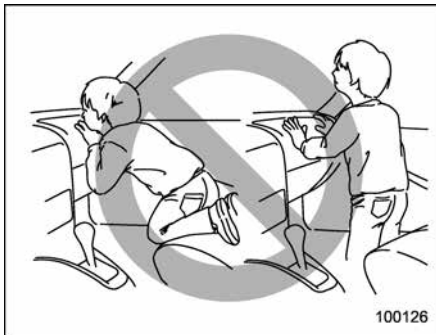

⚠ WARNING

Never allow a child to stand up or kneel on the front passenger's seat. The SRS airbag deploys with considerable force and can injure or even kill the child.



⚠ WARNING

Never hold a child on your lap or in your arms. The SRS airbag deploys with considerable force and can injure or even kill the child.

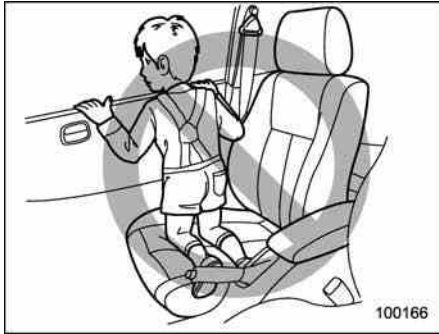

⚠ WARNING

- Never allow a child to do the following.
 - Kneel on any passenger's

seat facing the side window

- Wrap his/her arms around the front seat seatback
- Put his/her head, arms or other parts of the body out of the window

In the event of an accident, the force of SRS side airbag and/or SRS curtain airbag deployment could injure the child seriously because his/her head, arms or other parts of the body are too close to the SRS side airbag and/or SRS curtain airbag.

- Since your vehicle is also equipped with a front passenger's SRS frontal airbag, children aged 12 and under should be placed in the rear seat anyway and should be properly restrained at all times.

⚠ CAUTION

- When the SRS airbag deploys, some smoke will be released. This smoke could cause breathing problems for people with a history of asthma or other breathing trouble. If you or your passengers have breathing pro-

blems after SRS airbag deploys, get fresh air promptly.

- A deploying SRS airbag releases hot gas. Occupants could get burned if they come into direct contact with the hot gas.

NOTE

When you sell your vehicle, we urge you to explain to the buyer that it is equipped with SRS airbags by alerting the buyer to the applicable section in this Owner's Manual.

■ Components

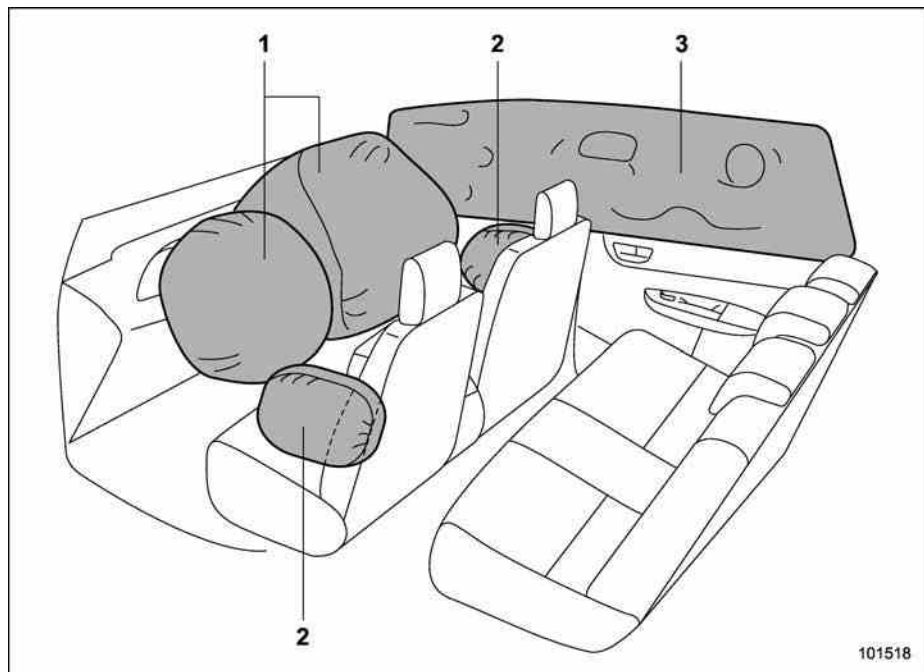

- 1) SRS frontal airbag
- 2) SRS side airbag
- 3) SRS curtain airbag

The SRS airbags are stowed in the following locations.

Driver's SRS frontal airbag: in the center portion of the steering wheel

Front passenger's SRS frontal airbag: near the top of the dashboard under an "SRS AIRBAG" mark

SRS side airbag: in the door side of each front seat seatback which bears an "SRS AIRBAG" label

SRS curtain airbag: in the roof side (between the front pillar and a point over the rear seat)

An "SRS AIRBAG" mark is located at the top of each center pillar.

101518

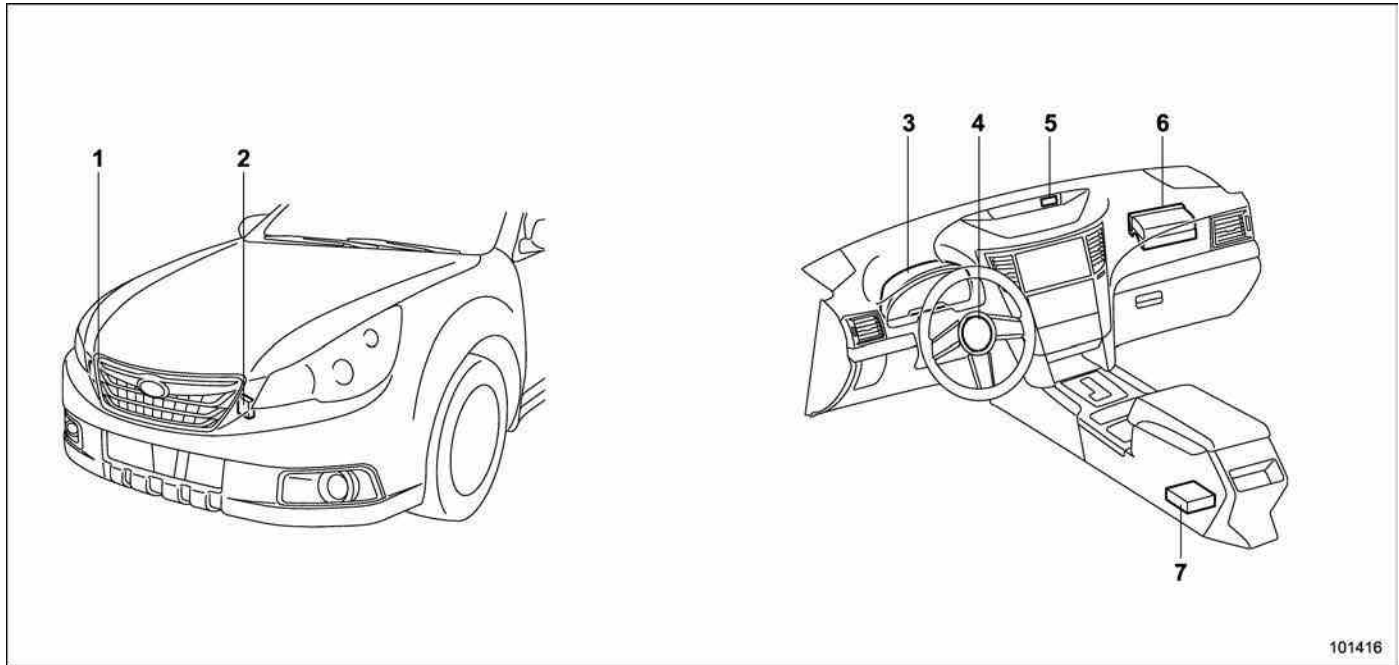

- 1) Front sub sensor (right-hand side)
- 2) Front sub sensor (left-hand side)
- 3) SRS airbag system warning light
- 4) Frontal airbag module (driver's side)

- 5) Front passenger's frontal airbag ON and OFF indicator
- 6) Frontal airbag module (front passenger's side)

- 7) Airbag control module (including impact sensor [all models] and rollover sensor [Outback])

101416

1-44 Seat, seatbelt and SRS airbags

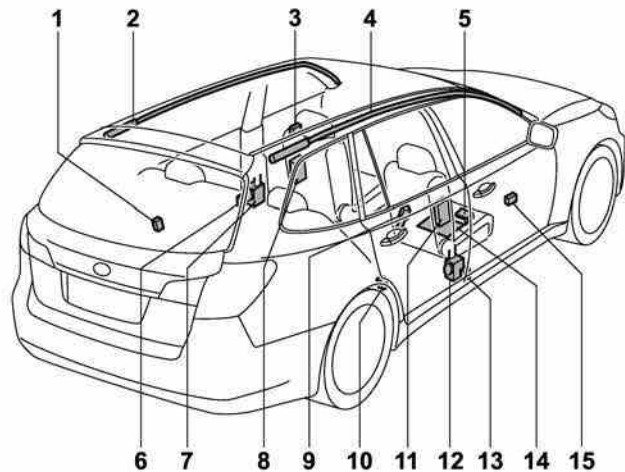
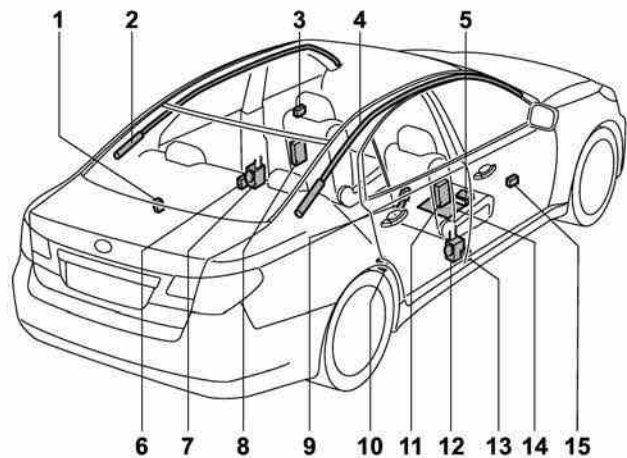

- 1) Rear wheel house impact sensor (left-hand side)
- 2) Curtain airbag module (left-hand side)
- 3) Front door impact sensor (left-hand side)
- 4) Curtain airbag module (right-hand side)
- 5) Front passenger's occupant detection control module
- 6) Center pillar impact sensor (left-hand side)
- 7) Seatbelt pretensioner (left-hand side)
- 8) Side airbag module (left-hand side)
- 9) Seatbelt buckle switch (right-hand side)
- 10) Rear wheel house impact sensor (right-hand side)
- 11) Side airbag module (right-hand side)
- 12) Seatbelt pretensioner (right-hand side)
- 13) Center pillar impact sensor (right-hand side)
- 14) Front passenger's occupant detection system weight sensor
- 15) Front door impact sensor (right-hand side)

■ SUBARU advanced frontal airbag system, SRS side airbag and SRS curtain airbag

Your vehicle is equipped with a SUBARU advanced frontal airbag system that complies with the new advanced frontal airbag requirements in the amended Federal Motor Vehicle Safety Standard (FMVSS) No. 208.

The SUBARU advanced frontal airbag system automatically determines the deployment force of the driver's SRS frontal airbag at the time of deployment as well as whether or not to activate the front passenger's SRS frontal airbag and, if activated, the deployment force of the SRS frontal airbag at the time of deployment.

Your vehicle has warning labels on the driver's and front passenger's sun visors beginning with the phrase "EVEN WITH ADVANCED AIR BAGS" and a tag attached to the glove box lid beginning with the phrase "Even with Advanced Air Bags". Make sure that you carefully read the instructions on the warning labels and tag.

Always wear your seatbelt. The SUBARU advanced frontal airbag system is a supplemental restraint system and must be used in combination with a seatbelt. All

occupants should wear a seatbelt or be seated in an appropriate child restraint system.

For the locations of the driver's SRS frontal airbag, front passenger's SRS frontal airbag, SRS side airbag and SRS curtain airbag, refer to "Components" 1-42.

In a moderate to severe frontal collision, the driver's and front passenger's SRS frontal airbags deploy and supplement the seatbelts by reducing the impact on the driver's and front passenger's head and chest.

In a moderate to severe side impact collision, the SRS side airbag on the impacted side of the vehicle deploys between the occupant and the door panel and supplements the seatbelt by reducing the impact to the occupant's chest and waist.

In a moderate to severe side impact collision, the SRS curtain airbag on the impacted side of the vehicle deploys between the occupant and the side window and supplements the seatbelt by reducing the impact to the occupant's head.

NOTE

The SRS side airbag, SRS curtain airbag and seatbelt pretensioner are not

controlled by the SUBARU advanced frontal airbag system.

▼ **Driver's SRS frontal airbag**

The driver's SRS frontal airbag uses a dual stage inflator. The inflator operates in different ways depending on the severity of impact.

Have the system inspected by your SUBARU dealer immediately if the SRS airbag system warning light illuminates.

▼ **Front passenger's SRS frontal airbag**

The front passenger's SRS frontal airbag uses a dual stage inflator. The inflator operates in different ways depending on the severity of impact.

The total load on the seat is monitored by the passenger's occupant detection system weight sensor under the seat.

Using the total seat load and seatbelt buckle switch, the occupant detection system determines whether the front passenger's SRS frontal airbag should or should not be inflated.

The occupant detection system may not inflate the front passenger's SRS frontal airbag even when the driver's SRS frontal airbag deploys. This is normal.



CAUTION

Observe the following precautions. Failure to do so may prevent the SUBARU advanced frontal airbag system from functioning correctly or cause the system to fail.

- Do not apply any strong impact to the front passenger's seat such as by kicking.
- Do not spill liquid on the front passenger's seat. If liquid is spilled, wipe it off immediately.
- Do not remove or disassemble the front passenger's seat.
- Do not install any accessory (such as an audio amplifier) other than a genuine SUBARU accessory under the front passenger's seat.
- Do not place anything (shoes, umbrella, etc.) under the front passenger's seat.
- Do not use the front passenger's seat with the head restraint removed.
- Do not leave any articles on the front passenger's seat or the seatbelt tongue and buckle engaged when you leave your ve-

hicle.

- Do not place a magnet near the seatbelt buckle and the seatbelt retractor.
- Do not use front seats with their backward-forward position and seatback not being locked into place securely. If any of them are not locked securely, adjust them again. For adjusting procedure, refer to "Manual seat" ④ 1-3 (models equipped with manual seats only).

If the seatbelt buckle switch and/or front passenger's occupant detection system have failed, the SRS airbag system warning light will illuminate. Have the system inspected by your SUBARU dealer immediately if the SRS airbag system warning light illuminates.

If your vehicle has sustained impact, this may affect the proper function of the SUBARU advanced frontal airbag system. Have your vehicle inspected at your SUBARU dealer.

▼ **Passenger's frontal airbag ON and OFF indicators**

Refer to "Front passenger's frontal airbag ON and OFF indicators" ④ 3-11.

▼ **Conditions in which front passenger's SRS frontal airbag is not activated**

The front passenger's SRS frontal airbag will not be activated when any of the following conditions are met regarding the front passenger's seat:

- The seat is empty.
- The seat is equipped with a rearward facing child restraint system and an infant is restrained with it. (See WARNING that follows.)
- The seat is equipped with a forward facing child restraint system and a small child is restrained with it. (See WARNING that follows.)
- The seat is equipped with a booster seat and a small child is in the booster seat. (See WARNING that follows.)
- The seat is relieved of the occupant load for a time exceeding the predetermined monitoring time period.
- The seat is occupied by a child who has outgrown a child restraint system (See WARNING that follows.) or by a small adult.
- The front passenger's occupant detection system is malfunctioning.



WARNING

NEVER INSTALL A REARWARD FACING CHILD SEAT IN THE FRONT PASSENGER'S SEAT EVEN IF THE FRONT PASSENGER'S SRS FRONTAL AIRBAG IS DEACTIVATED. Be sure to install it in the REAR seat in a correct manner. Also, it is strongly recommended that any forward facing child seat or booster seat be installed in the REAR seat, and that even children who have outgrown a child restraint system be also seated in the REAR seat. This is because children sitting in the front passenger's seat may be killed or severely injured should the front passenger's SRS frontal airbag deploy. REAR seats are the safest place for children.



CAUTION

When the front passenger's seat is occupied by a child, observe the following precautions. Failure to do so may increase the load on the front passenger's seat, activating the front passenger's SRS frontal airbag even though that seat is occupied by a child.

- Do not place any article on the seat other than the child occupant and a child restraint system.
- Do not place more than one child on the seat.
- Do not install any accessory such as a table or TV onto the seatback.
- Do not store a heavy load in the seatback pocket.
- Do not allow the rear seat occupant to place his/her hands or legs on the front passenger's seatback, or allow him/her to pull the seatback.

▽ **If the front passenger's frontal airbag ON indicator illuminates and the OFF indicator turns off even when an infant or a small child is in a child restraint system (including booster seat)**

1. Turn the ignition switch to the "LOCK" position.
2. Remove the child restraint system from the seat.
3. By referring to the child restraint manufacturer's recommendations as well as the child restraint system installation procedures in "Child restraint systems"

☞ 1-23, correctly install the child restraint system.

4. Turn the ignition switch to the “ON” position and make sure that the front passenger’s frontal airbag ON indicator turns off and the OFF indicator illuminates.

If still the ON indicator remains illuminated while the OFF indicator turns off, take the following actions.

- Ensure that no article is placed on the seat other than the child restraint system and the child occupant.
- Ensure that there is no article left in the seatback pocket.
- Ensure that the backward-forward position and seatback of front passenger’s seat are locked into place securely by moving the seat back and forth. (Models equipped with manual seats only)

If the ON indicator still remains illuminated while the OFF indicator turns off after taking relevant corrective actions described above, relocate the child restraint system to the rear seat and immediately contact your SUBARU dealer for an inspection.

NOTE

When a child who has outgrown a child restraint system or a small adult is seated in the front passenger’s seat,

the SUBARU advanced frontal airbag system may or may not activate the front passenger’s SRS frontal airbag depending on the occupant’s seating posture. If the front passenger’s SRS frontal airbag is activated (the ON indicator remains illuminated while the OFF indicator turns off), take the following actions.

- Ensure that no article is placed on the seat other than the occupant.
- Ensure that there is no article left in the seatback pocket.

If the ON indicator still remains illuminated while the OFF indicator turns off despite the fact that the actions noted above have been taken, seat the child/small adult in the rear seat and immediately contact your SUBARU dealer for an inspection. Even if the system has passed the dealer inspection, it is recommended that on subsequent trips the child/small adult always take the rear seat.

Children who have outgrown a child restraint system should always wear the seatbelt irrespective of whether the airbag is deactivated or activated.

▼ Conditions in which front passenger’s SRS frontal airbag is activated

The front passenger’s SRS frontal airbag

will be activated for deployment upon impact when any of the following conditions is met regarding the front passenger’s seat.

- When the seat is occupied by an adult.
- When a heavy article is placed on the seat.



CAUTION

When the front passenger’s seat is occupied by an adult, observe the following precautions. Failure to do so may lessen the load on the front passenger’s seat, deactivating the front passenger’s SRS frontal airbag despite the fact that the seat is occupied by an adult. This may result in personal injury.

- Do not allow the rear seat occupant to lift the front passenger’s seat cushion using his/her feet.
- Do not place any article under the front passenger’s seat, or squeeze any article from behind and under the seat. This may lift the seat cushion.

- **Do not squeeze any article between the front passenger's seat and side trim/pillar, door or center console box. This may lift the seat cushion.**

▽ **If the passenger's frontal airbag OFF indicator illuminates and the ON indicator turns off even when the front passenger's seat is occupied by an adult**

This can be caused by the adult incorrectly sitting in the front passenger's seat.

1. Turn the ignition switch to the "LOCK" position.
2. Ask the front passenger to set the seatback to the upright position, sit up straight in the center of the seat cushion, correctly fasten the seatbelt, position his/her legs out forward, and adjust the seat to the rearmost position.
3. Turn the ignition switch to the "ON" position.

If the OFF indicator remains illuminated while the ON indicator remains off, take the following actions.

1. Turn the ignition switch to the "LOCK" position.
2. Ensure that there is no article, book, shoe, or other object trapped under the seat, at the rear of the seat, or on the side

of the seat.

3. Ensure that the backward-forward position and seatback of front passenger's seat are locked into place securely by moving the seat back and forth. (Models equipped with manual seats only)

4. Turn the ignition switch to the "ON" position and wait 6 seconds to allow the system to complete self-checking. Following the system check, both indicators turn off for 2 seconds. Now, the ON indicator should illuminate while the OFF indicator remains off.

If the OFF indicator still remains illuminated while the ON indicator remains off, ask the occupant to move to the rear seat and immediately contact your SUBARU dealer for an inspection.

▼ **Effect vehicle modifications made for persons with disabilities may have on SUBARU advanced frontal airbag system operation (U.S. only)**

Changing or moving any parts of the front seats, seatbelts, front bumper, front side frame, instrument panel, combination meter, steering wheel, steering column, tire, suspension or floor panel can affect the operation of the SUBARU advanced airbag system. If you have any questions, you may contact the following SUBARU distributors:

<Continental U.S., Alaska and the District of Columbia>

Subaru of America, Inc.

Customer Dealer Services Department

P.O. Box 6000

Cherry Hill, NJ 08034-6000

1-800-SUBARU3 (1-800-782-2783)

<Hawaii>

Servco Subaru Inc., dba Subaru Hawaii
2850 Pukoloa Street, Suite 202, Honolulu,
HI 96819

808-839-2273

<Guam>

Shen's Corporation dba Prestige Automobile

491, East Marine Drive, Route 1 Dededo,
Guam

671-633-2698

<Puerto Rico>

Trebol Motors

P.O. Box 11204, San Juan, Puerto Rico
00910

787-793-2828

There are currently no SUBARU distributors in any other U.S. territories. If you are in such an area, please contact the SUBARU distributor or dealer from which you bought your vehicle.

■ System operation

⚠ CAUTION

Do not touch the SRS airbag system components with bare hands right after deployment. Doing so can cause burns because the components can be very hot as a result of deployment.

The SRS airbags can function only when the ignition switch is in the "ON" position.

When the SRS airbag(s) deploy(s), a sudden, fairly loud inflation noise will be heard and some smoke will be released. These occurrences are a normal result of the deployment. This smoke does not indicate a fire in the vehicle.

▼ SUBARU advanced frontal airbag operation

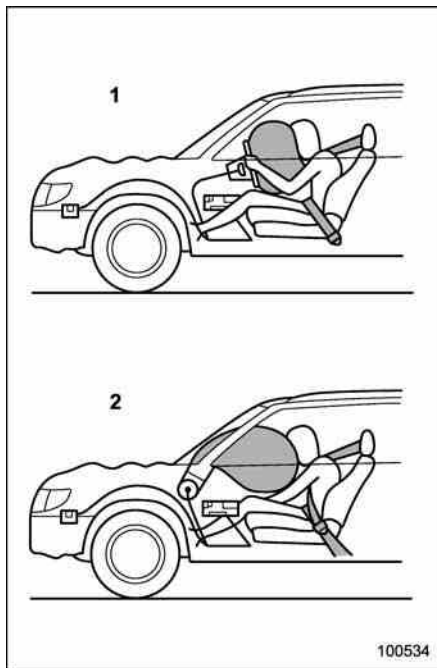

- 1) Driver's side
- 2) Passenger's side

The SUBARU advanced frontal airbag system is designed to determine the

activation or deactivation condition of the front passenger's SRS frontal airbag depending on the total load on the front passenger's seat monitored by the front passenger's occupant detection system weight sensor. For this reason, only the driver's SRS frontal airbag may deploy in the event of a collision, but this does not mean failure of the system.

If the front sub sensors inside both front fenders and the impact sensors in the airbag control module detect a predetermined amount of force during a frontal collision, the control module sends signals to the airbag module(s) (only driver's module or both driver's and front passenger's modules) instructing the module(s) to inflate the SRS frontal airbag(s). The driver's and front passenger's SRS frontal airbags use dual stage inflators. The two inflators of each airbag are triggered either sequentially or simultaneously, depending on the severity of impact in the case of the driver's SRS frontal airbag and depending on the severity of impact and the total load on the seat in the case of the front passenger's SRS frontal airbag.

After deployment, the SRS airbag immediately starts to deflate so that the driver's vision is not obstructed and the driver's ability to maintain control of the vehicle is

not impaired. The time required from detecting impact to the deflation of the SRS airbag after deployment is shorter than the blink of an eye.

Both when only the driver's SRS frontal airbag deploys and the driver's and front passenger's SRS frontal airbags deploy, the driver's and front passenger's seatbelt pretensioners operate at the same time.

The driver's SRS frontal airbag and front passenger's SRS frontal airbag are designed to deploy in the event of an accident involving a moderate to severe frontal collision. They are basically not designed to deploy in lesser frontal impacts because the necessary protection can be achieved by the seatbelt alone. Also, they are basically not designed to deploy in side or rear impacts or in rollover accidents because deployment of only the driver's SRS frontal airbag or both driver's and front passenger's SRS frontal airbags would not help the occupant in those situations. The driver's and front passenger's SRS frontal airbags are designed to function on a one-time-only basis.

SRS airbag deployment depends on the level of force experienced in the passenger compartment during a collision. That level differs from one type of collision to another, and it may have no bearing on

the visible damage done to the vehicle itself.

- ▽ **Examples of accident in which the driver's/driver's and front passenger's SRS frontal airbag(s) will most likely deploy.**

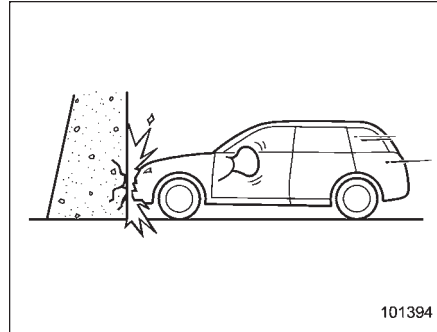

A head-on collision against a thick concrete wall at a vehicle speed of 12 to 19 mph (20 to 30 km/h) or higher activates only the driver's SRS frontal airbag or both driver's and front passenger's SRS frontal airbags. The airbag(s) will also be activated when the vehicle is exposed to a frontal impact similar in fashion and magnitude to the collision described above.

- ▽ **Examples of the types of accidents in which it is possible that the driver's/driver's and front passenger's SRS frontal airbag(s) will deploy.**

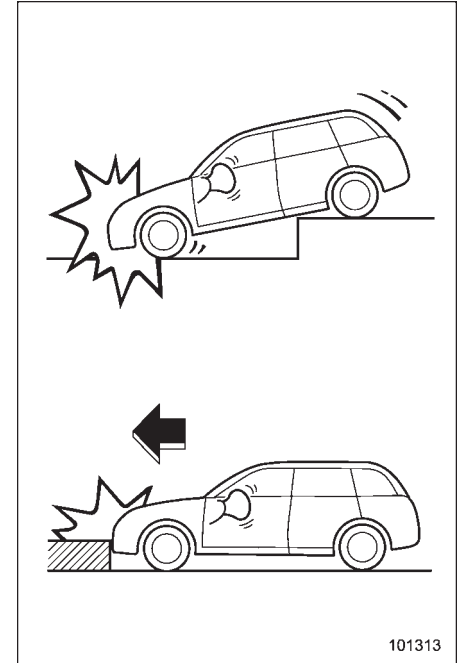

Only the driver's SRS frontal airbag or

both driver's and front passenger's SRS frontal airbags may be activated when the vehicle sustains a hard impact in the undercarriage area from the road surface (such as when the vehicle plunges into a deep ditch, is severely impacted or knocked hard against an obstacle on the road such as a curb).

▽ Examples of the types of accidents in which deployment of the driver's/driver's and front passenger's SRS frontal airbag(s) is unlikely to occur.

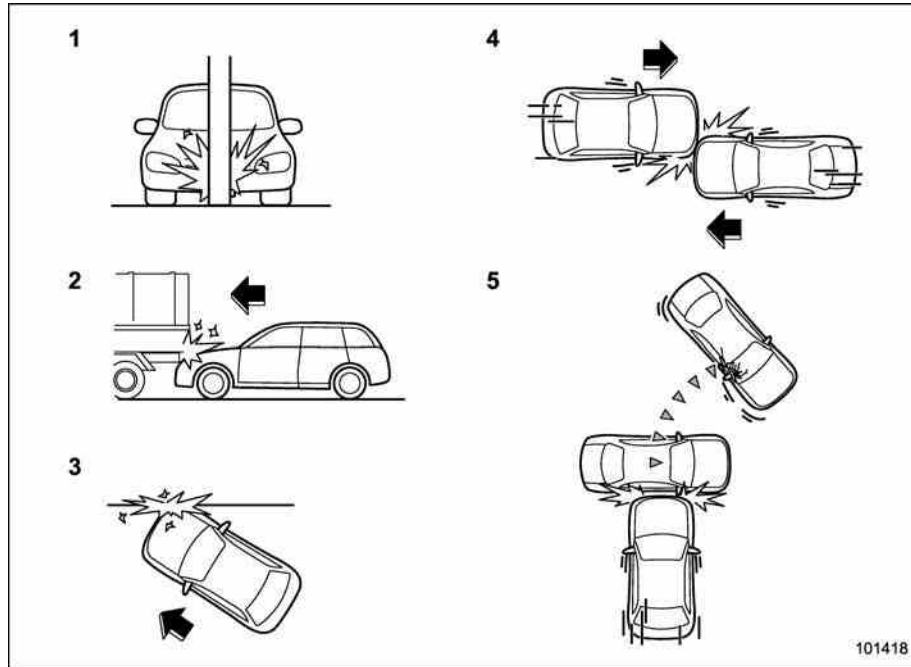

- 1) The vehicle strikes an object, such as a telephone pole or sign pole.
- 2) The vehicle slides under the load bed of a truck.
- 3) The vehicle sustains an oblique offset frontal impact.
- 4) The vehicle sustains an offset frontal collision.
- 5) The vehicle strikes an object that can move or deform, such as a parked vehicle.

There are many types of collisions which might not necessarily require deployment of driver's/driver's and front passenger's SRS frontal airbag(s). In the event of accidents like those illustrated, the driver's/driver's and front passenger's SRS frontal airbag(s) may not deploy depending on the level of accident forces involved.

▽ Examples of the types of accidents in which the driver's/driver's and front passenger's SRS frontal airbag(s) will basically not deploy.

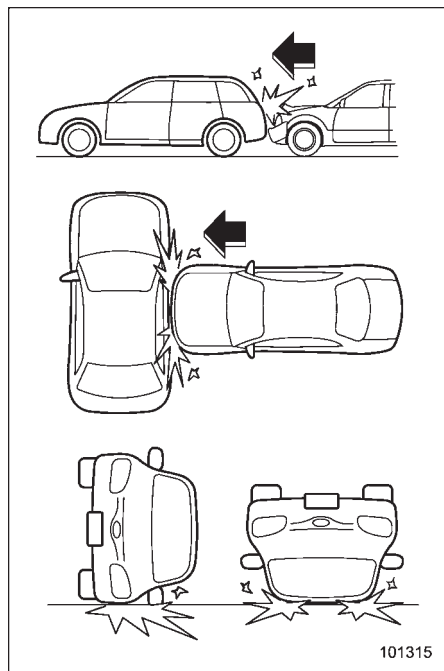

The driver's and front passenger's SRS frontal airbags are designed basically not

to deploy if the vehicle is struck from the side or from behind, or if it rolls onto its side or roof, or if it is involved in a low-speed frontal collision.

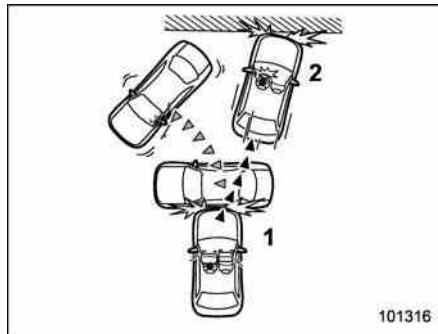

- 1) First impact
- 2) Second impact

In an accident where the vehicle is impacted more than once, the driver's and/or front passenger's SRS frontal airbag(s) will deploy only once on the first impact.

Example: In the case of a double collision, first with another vehicle, then against a concrete wall in immediate succession, once either or both of the driver's and front passenger's SRS frontal airbags is/are activated on the first impact, it/they will not be activated on the second impact.

WARNING

If the vehicle is damaged in an accident but the SRS frontal airbag does not deploy, contact your SUBARU dealer as soon as possible.

▽ SRS side airbag and SRS curtain airbag operation



The driver's and front passenger's SRS side airbags and SRS curtain airbags deploy independently of each other because each has its own impact sensor. Therefore, they may not both deploy in the same accident. Also, the SRS side airbag and SRS curtain airbag deploys independently of the driver's and front passenger's SRS frontal airbags in the steering

wheel and instrument panel.

An impact sensor, which senses impact force, is located in each of the following locations.

- In the left and right front doors
- In the left and right center pillars
- In the left and right rear wheel houses
- In the airbag control module

For Outback models, a rollover sensor is also located inside the airbag control module.

If the impact sensor that is located in the airbag control module and one of the center pillar impact sensors or front door impact sensors together sense an impact force above a predetermined level in a side collision, the control module causes both the SRS side airbag and curtain airbag on the impacted side to inflate regardless of whether the rear wheel house impact sensor on the same side senses an impact.

If the impact sensor that is located in the airbag control module and one of the rear wheel house impact sensors together sense an impact force above a predetermined level in a side collision, the control module causes only the SRS curtain airbag on the impacted side to inflate.

For Outback models, if the rollover sensor detects rollover of the vehicle, the control module inflates the SRS curtain airbags. At this time, the driver's and front passenger's seatbelt pretensioners also operate at the same time.

After the deployment, the SRS side airbag immediately starts to deflate. The time required from detection of an impact to deflation of an SRS side airbag after deployment is shorter than the blink of an eye.

The SRS curtain airbag remains inflated for a while following deployment then slowly deflates.

The SRS side airbag and SRS curtain airbag deploy even when no one occupies the seat on the side on which an impact is applied.

The SRS side airbag and SRS curtain airbag are designed to deploy in the event of an accident involving a moderate to severe side impact collision. They are basically not designed to deploy in a lesser side impact.

The SRS side airbag and SRS curtain airbag deployment depend on the level of force experienced in the passenger compartment during a side impact collision. That level differs from one type of collision

to another, and it may have no bearing on the visible damage done to the vehicle itself.

For Outback models, the SRS curtain airbags are also designed to deploy when the vehicle is in an extremely inclined state such as during a rollover. They are basically not designed to deploy in a lesser inclined state.

The SRS side airbag and SRS curtain airbag are basically not designed to deploy in frontal or rear impacts because the SRS side airbag and SRS curtain airbag deployment would not help the occupant in those situations.

Each SRS side airbag and SRS curtain airbag are designed to function on a one-time-only basis.

- ▽ Example of the type of accident in which the SRS side airbag will most likely deploy.

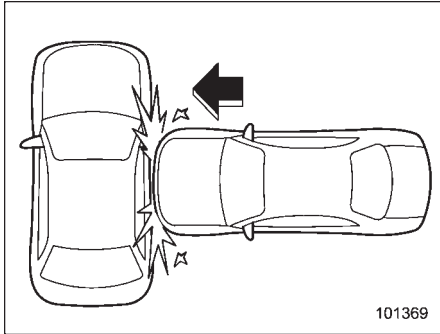

A severe side impact near the front seat activates the SRS side airbag.

- ▽ Examples of the types of accidents in which the SRS curtain airbag will most likely deploy.

Legacy models

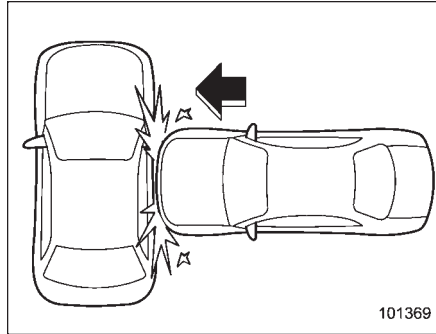

A severe side impact near the front seat or the rear seat activates the SRS curtain airbag.

Outback models

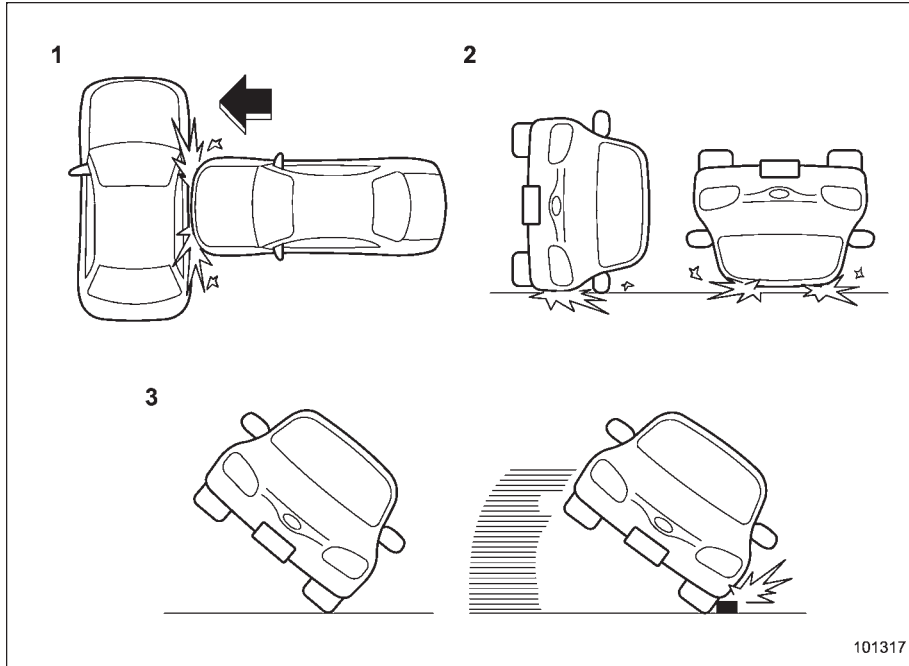

- 1) The vehicle is involved in a severe side impact near the front seat or the rear seat.
- 2) The vehicle rolls onto its side or the roof.
- 3) The angle of vehicle tip-up is marginal or the skidding vehicle's tires hit a curb-stone laterally.

▽ **Examples of the types of accidents in which it is possible that the SRS side airbag and the SRS curtain airbag will deploy (Outback).**

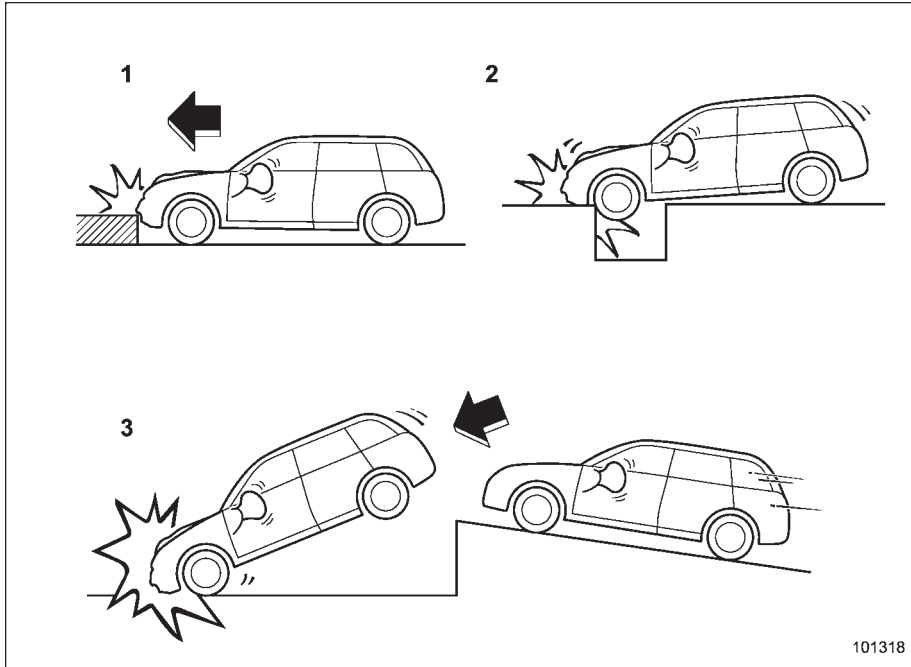

- 1) Hitting a curb, edge of pavement or hard surface
- 2) Falling into or jumping over a deep hole
- 3) Landing hard or vehicle falling

It is possible that the SRS side and curtain airbags will deploy if a serious impact occurs to the underside of your vehicle. Some examples are shown in the illustration.

▽ Examples of the types of accidents in which the SRS side airbag is unlikely to deploy.

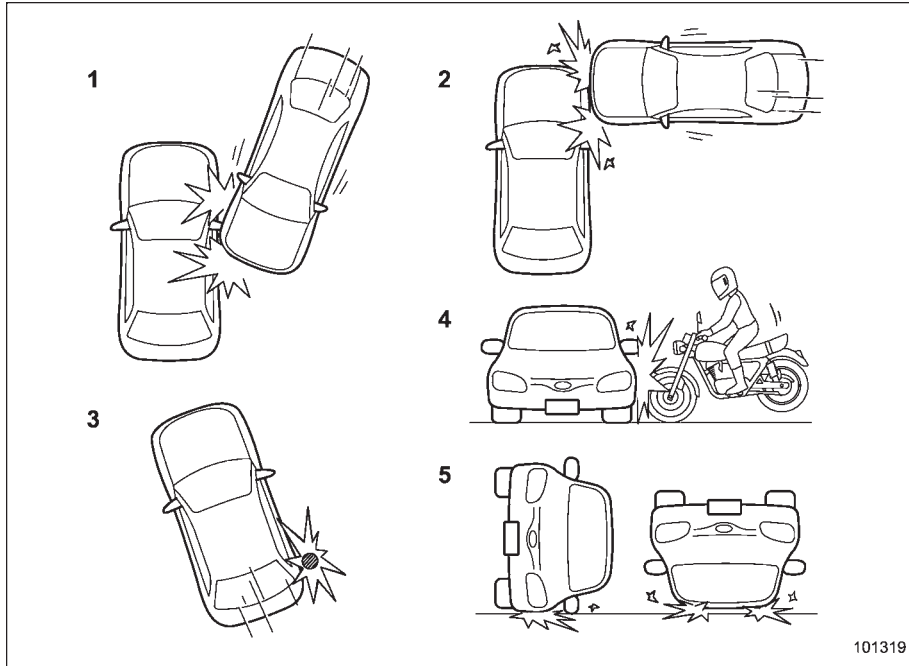

- 1) The vehicle is involved in an oblique side-on impact.
- 2) The vehicle is involved in a side-on impact in an area outside the vicinity of the passenger compartment.
- 3) The vehicle strikes a telephone pole or similar object.
- 4) The vehicle is involved in a side-on impact from a motorcycle.
- 5) The vehicle rolls onto its side or the roof.

There are many types of collisions which might not necessarily require SRS side airbag deployment. In the event of accidents like those illustrated, the SRS side airbag may not deploy depending on the level of accident forces involved.

▽ **Examples of the types of accidents in which the SRS curtain airbag is unlikely to deploy.**

Legacy models

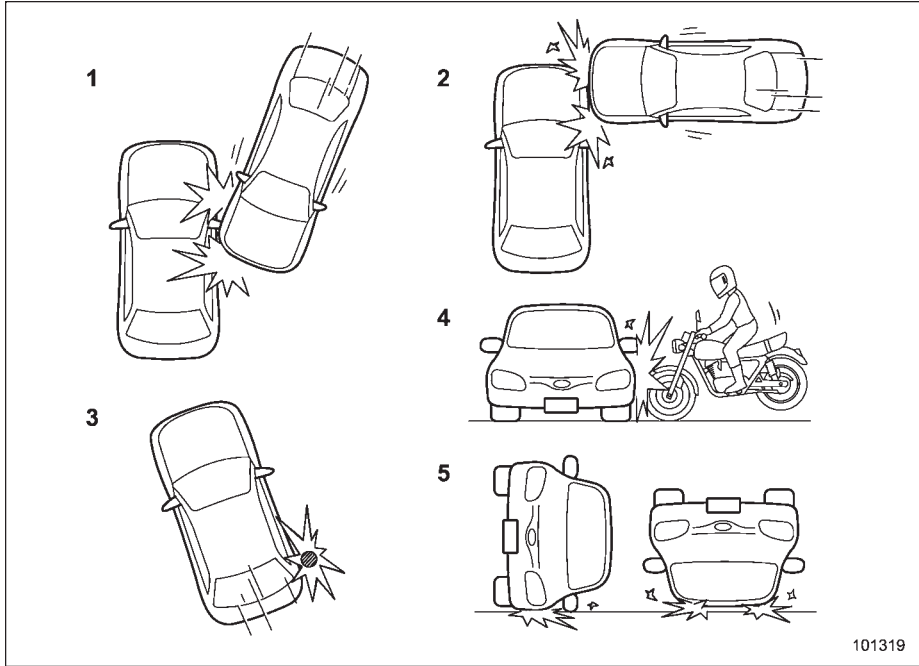

- 1) The vehicle is involved in an oblique side-on impact.
- 2) The vehicle is involved in a side-on impact in an area outside the vicinity of the passenger compartment.
- 3) The vehicle strikes a telephone pole or similar object.
- 4) The vehicle is involved in a side-on impact from a motorcycle.
- 5) The vehicle rolls onto its side or the roof.

There are many types of collisions which might not necessarily require SRS curtain airbag deployment. In the event of accidents like those illustrated, the SRS curtain airbag may not deploy depending on the level of accident forces involved.

Outback models

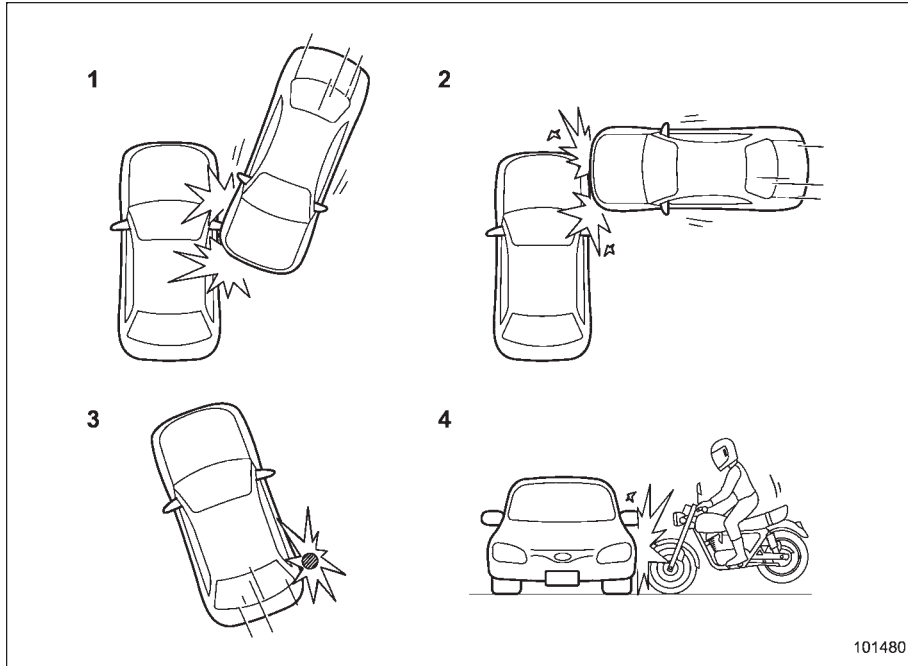

- 1) The vehicle is involved in an oblique side-on impact.
- 2) The vehicle is involved in a side-on impact in an area outside the vicinity of the passenger compartment.
- 3) The vehicle strikes a telephone pole or similar object.
- 4) The vehicle is involved in a side-on impact from a motorcycle.

There are many types of collisions which might not necessarily require SRS curtain airbag deployment. In the event of accidents like those illustrated, the SRS curtain airbag may not deploy depending on the level of accident forces involved.

▽ Examples of the types of accidents in which the SRS side airbag and SRS curtain airbag will basically not deploy.

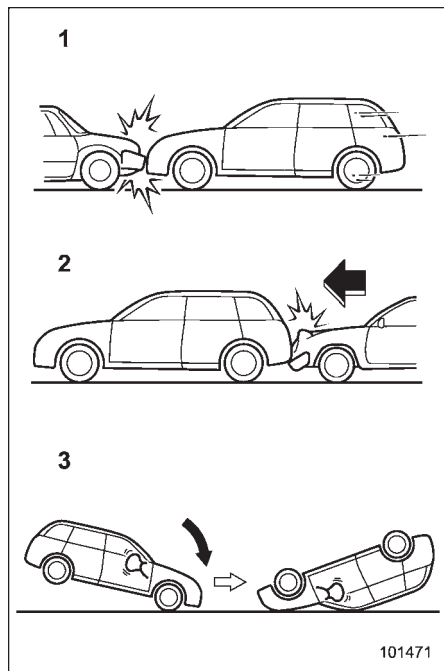

- 1) The vehicle is involved in frontal collision with another vehicle (moving or stationary).

- 2) The vehicle is struck from behind.
- 3) The vehicle pitches end over end.

In the event of accidents like those illustrated, the SRS side airbag and SRS curtain airbag are basically not designed to deploy.

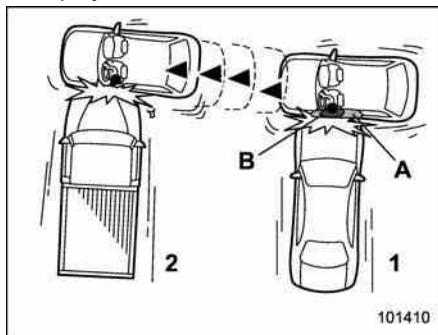

- 1) First impact
- 2) Second impact
- A) SRS curtain airbag
- B) SRS side airbag

In an accident where the vehicle is struck from the side more than once, the SRS side airbag and SRS curtain airbag deploy only once on the first impact.

Example: In the case of a double impact collision, first with one vehicle and immediately followed by another from the same direction, once the SRS side airbag

and SRS curtain airbag are activated on the first impact, they will not be activated on the second.

■ SRS airbag system monitors

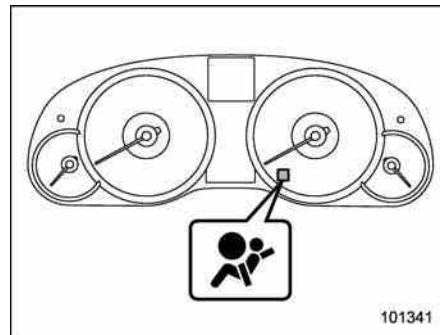

SRS airbag system warning light

A diagnostic system continually monitors the readiness of the SRS airbag system (including front seatbelt pretensioners) while the vehicle is being driven. The SRS airbag system warning light will show normal system operation by illuminating for approximately 6 seconds when the ignition switch is turned to the "ON" position.

The following components are monitored by the indicator.

- Front sub sensor
 - Right-hand side
 - Left-hand side
- Airbag control module (including impact sensors [all models] and rollover sensors [Outback])
- Frontal airbag module
 - Driver's side
 - Front passenger's side
- Center pillar impact sensor
 - Right-hand side
 - Left-hand side
- Front door impact sensor
 - Right-hand side
 - Left-hand side
- Side airbag module
 - Driver's side
 - Front passenger's side
- Rear wheel house impact sensor
 - Right-hand side
 - Left-hand side
- Curtain airbag module
 - Right-hand side
 - Left-hand side
- Seatbelt pretensioner
 - Driver's side
 - Front passenger's side
- Seatbelt buckle switch (front passenger's side)
- Front passenger's occupant detection

system weight sensor

- Front passenger's occupant detection control module
- Front passenger's frontal airbag ON and OFF indicator
- All related wiring



WARNING

If the warning light exhibits any of the following conditions, there may be a malfunction in the seatbelt pretensioners and/or SRS airbag system. Immediately take your vehicle to your nearest SUBARU dealer to have the system checked. Unless checked and properly repaired, the seatbelt pretensioners and/or SRS airbags will operate improperly (e.g. SRS airbags may inflate in a very minor collision or not inflate in a severe collision), which may increase the risk of injury.

- Flashing or flickering of the warning light
- No illumination of the warning light when the ignition switch is first turned to the "ON" position
- Continuous illumination of the warning light
- Illumination of the warning light

while driving

■ SRS airbag system servicing



WARNING

- When discarding an airbag module or scrapping the entire vehicle damaged by a collision, consult your SUBARU dealer.
- The SRS airbag has no user-serviceable parts. Do not use electrical test equipment on any circuit related to the SRS airbag system. For required servicing of the SRS airbag, consult your nearest SUBARU dealer. Tampering with or disconnecting the system's wiring could result in accidental inflation of the SRS airbag or could make the system inoperative, which may result in serious injury.



CAUTION

If you need service or repair in areas indicated in the following list, have the work performed by an authorized SUBARU dealer. The SRS airbag control module, impact sensors and airbag modules are stored in these areas.

- Under the center console
- Inside each front fender
- Steering wheel and column and nearby areas
- Top of the dashboard on front passenger's side and nearby areas
- Each front seat and nearby area
- Inside each center pillar
- Inside each front door
- In each roof side (from the front pillar to a point over the rear seat)
- Between the rear seat cushion and rear wheel house on each side
- Under the rear center seat

In the event that the SRS airbag is deployed, replacement of the system should be performed only by an authorized SUBARU dealer. When the compo-

nents of the SRS airbag system are replaced, use only genuine SUBARU parts.

NOTE

In the following cases, contact your SUBARU dealer as soon as possible.

- The front part of the vehicle was involved in an accident in which only the driver's SRS frontal airbag or both driver's and front passenger's SRS frontal airbags did not deploy.
- The pad of the steering wheel, the cover over the front passenger's SRS frontal airbag, or either roof side (from the front pillar to a point over the rear seat) is scratched, cracked, or otherwise damaged.
- The center pillar, front door, rear wheel house or rear sub frame, or an area near these parts, was involved in an accident in which the SRS side airbag and SRS curtain airbag did not deploy.
- The fabric or leather of either front seatback is cut, frayed, or otherwise damaged.
- The rear part of the vehicle was involved in an accident.

■ Precautions against vehicle modification



WARNING

To avoid accidental activation of the system or rendering the system inoperative, which may result in serious injury, no modifications should be made to any components or wiring of the SRS airbag system.

This includes the following modifications.

- Installation of custom steering wheels
- Attachment of additional trim materials to the dashboard
- Installation of custom seats
- Replacement of seat fabric or leather
- Installation of additional fabric or leather on the front seat
- Attachment of a hands-free microphone or any other accessory to a front pillar, a center pillar, a rear pillar, the windshield, a side window, an assist grip, or any other cabin surface that would be near a deploying SRS curtain airbag

- Installation of additional electrical/electronic equipment such as a mobile two-way radio on or near the SRS airbag system components and/or wiring
- Modifications on or inside the front door panels for the purpose of a speaker replacement or sound insulation

**CAUTION**

Do not perform any of the following modifications. Such modifications can interfere with proper operation of the SRS airbag system.

- Attachment of any equipment (bush bar, bullbar, winches, snow plow, skid/sump plate, etc.) other than genuine SUBARU accessory parts.
- Modification of the suspension system or front end structure.
- Installation of a tire of different size and construction from the tires specified on the vehicle placard attached to the driver's door pillar or specified for individual vehicle models in this Owner's Manual.

- Attachment of any equipment (side steps or side sill protectors, etc.) other than genuine SUBARU accessory parts to the side body.

Always consult your SUBARU dealer if you want to install any accessory parts on your vehicle.

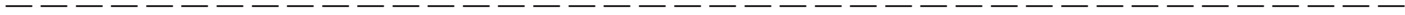
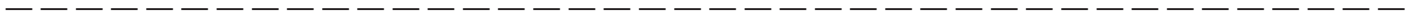
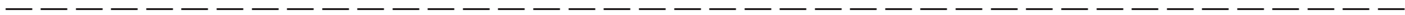

Keys	2-2	Alarm system	2-15
Key number	2-2	System alarm operation	2-15
Immobilizer	2-3	Activating and deactivating the alarm system	2-15
Security ID plate	2-3	If you have accidentally triggered the alarm system	2-16
Security indicator light	2-4	Arming the system	2-16
Key replacement	2-4	Disarming the system	2-17
Door locks	2-4	Valet mode	2-18
Locking and unlocking from the outside	2-4	Passive arming	2-18
Locking and unlocking from the inside	2-5	Tripped sensor identification	2-19
Battery drainage prevention function	2-6	Shock sensors (dealer option)	2-19
Power door locking switches	2-6	Child safety locks	2-19
Key lock-in prevention function	2-7	Windows	2-20
Remote keyless entry system	2-7	Power window operation by driver	2-20
Locking the doors	2-8	Power window operation by passengers	2-22
Unlocking the doors	2-9	Initialization of power window	2-23
Opening the trunk lid (Legacy)	2-9	Trunk lid (Legacy)	2-23
Unlocking the rear gate (Outback)	2-9	To open and close the trunk lid from outside	2-23
Vehicle finder function	2-9	To open the trunk lid from inside	2-24
Sounding a panic alarm	2-10	Internal trunk lid release handle	2-24
Selecting audible signal operation	2-10	Rear gate (Outback)	2-26
Replacing the battery	2-10	Moonroof (if equipped)	2-27
Replacing lost transmitters	2-12	Moonroof switches	2-28
		Sun shade	2-29

Keys

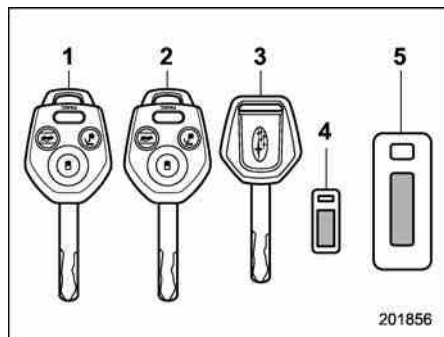

- 1) Master key
- 2) Submaster key
- 3) Valet key
- 4) Key number plate
- 5) Security ID plate

Three types of keys are provided for your vehicle:

Master key, submaster key and valet key.

The master key and submaster key fit all locks on your vehicle.

- Ignition switch
- Driver's door
- Glove box
- Trunk lid (Legacy)

The valet key fits only the ignition switch

and door locks. You can keep the trunk and glove box locked when you leave your vehicle and valet key at a parking facility.

CAUTION

Do not attach a large key holder or key case to either key. If it bangs against your knees while you are driving, it could turn the ignition switch from the "ON" position to the "Acc" or "LOCK" position, thereby stopping the engine.

Key number

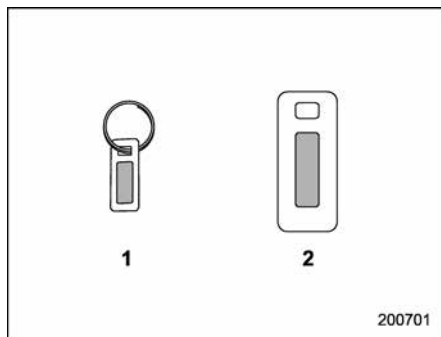

- 1) Key number plate
- 2) Security ID plate

The key number is stamped on the key

number plate attached to the key set. Write down the key number and keep it in another safe place, not in the vehicle. This number is needed to make a replacement key if you lose your key or lock it inside the vehicle.

To make replacement keys, the security ID is also needed. Refer to "Key replacement" 2-4.

Immobilizer

The immobilizer system is designed to prevent an unauthorized person from starting the engine. Only keys registered with your vehicle's immobilizer system can be used to operate your vehicle. Even if an unregistered key fits into the ignition switch and can be turned to the "START" position, the engine will automatically stop after several seconds.

Each immobilizer key contains a transponder in which the key's ID code is stored. When a key is inserted into the ignition switch and turned to the "ON" position, the transponder transmits the key's ID code to the immobilizer system's receiver. If the transmitted ID code matches the ID code registered in the immobilizer system, the system allows the engine to be started. Since the ID code is transmitted and acted upon almost instantly, the immobilizer system does not impede normal starting of the engine.

If the engine does not start, pull out the key once before trying again. Refer to "Ignition switch" 3-3.

This device complies with Part 15 of the FCC Rules and RSS-Gen of IC Rules. Operation is subject to the following two conditions: (1) This de-

vice may not cause harmful interference, and (2) this device must accept any interference received, including interference that may cause undesired operation.



CAUTION

- Do not place the key under direct sunlight or anywhere it may become hot.
- Do not get the key wet. If the key gets wet, wipe it dry with a cloth immediately.
- **FCC WARNING**
Changes or modifications not expressly approved by the party responsible for compliance could void the user's authority to operate the equipment.

NOTE

To protect your vehicle from theft, please pay close attention to the following security precautions:

- Never leave your vehicle unattended with its keys inside.
- Before leaving your vehicle, close all windows and the moonroof, and lock the doors (all models) and rear gate (Outback).

- Do not leave spare keys or any record of your key number in the vehicle.

Security ID plate

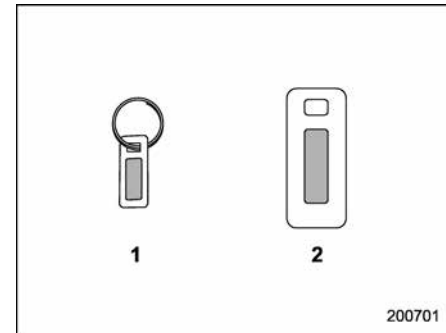

- 1) Key number plate
- 2) Security ID plate

The security ID is stamped on the security ID plate attached to the key set. Write down the security ID and keep it in another safe place, not in the vehicle. This number is needed to make a replacement key if you lose your key or lock it inside the vehicle.

To make replacement keys, the key number is also needed. Refer to "Key replacement" 2-4.

The security ID is also needed for replacement or repair of the engine control unit, integrated unit, etc. For details, consult your SUBARU dealer.

■ Security indicator light

Refer to "Security indicator light" 3-21.

■ Key replacement

Your key number plate and security ID plate will be required if you ever need a replacement key made. Any new key must be registered for use with your vehicle's immobilizer system before it can be used. Up to four keys can be registered for use with one vehicle.

For security, all the keys registered with your vehicle's immobilizer system will have their ID codes erased and re-registered when a new key is made. Therefore, all of your vehicle's keys must be presented when a new key is registered. Any key that is not re-registered when a new key is made cannot be used after the other keys are re-registered. For information on replacement keys and on the registration of keys with your immobilizer system, contact your SUBARU dealer.

Door locks

■ Locking and unlocking from the outside

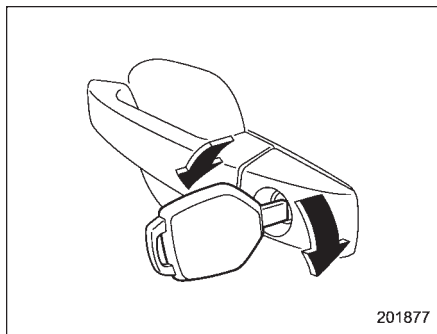

To lock the driver's door from the outside with the key, turn the key toward the rear. To unlock the door, turn the key toward the front.

Pull the outside door handle to open an unlocked door.

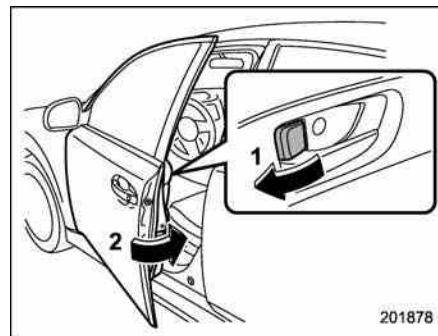

Locking without the key

- 1) Rotate the lock lever rearward.
- 2) Close the door.

To lock the door from the outside without the key, rotate the lock lever rearward and then close the door.

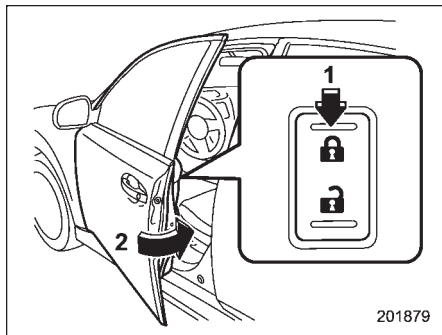

Locking without the key

- 1) Press the front side of the power door locking switch.
- 2) Close the door.

To lock the door from the outside using the power door locking switch, press the front side of the switch (“LOCK” side) and then close the door. In this case, all closed doors and the rear gate (Outback) are locked at the same time.

Always make sure that all doors and the rear gate are locked before leaving your vehicle.

NOTE

Make sure that you do not leave the key inside the vehicle before locking the doors from the outside without the key.

Locking and unlocking from the inside

WARNING

Keep all doors locked when you drive, especially when small children are in your vehicle.

Along with the proper use of seatbelts and child restraints, locking the doors reduces the chance of being thrown out of the vehicle in an accident.

It also helps prevent passengers from falling out by preventing a door from being accidentally opened, and intruders from unexpectedly opening doors and entering your vehicle.

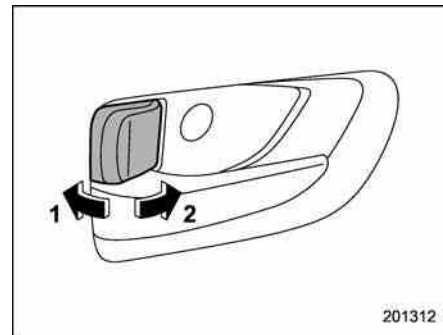

- 1) Lock
- 2) Unlock

To lock the door from the inside, rotate the lock lever rearward. To unlock the door from the inside, rotate the lock lever forward.

The red mark on the lock lever appears when the door is unlocked.

Pull the inside door handle to open an unlocked door.

Always make sure that all doors and the rear gate (Outback) are closed before starting to drive.

■ Battery drainage prevention function

If a door or the rear gate (Outback) is not completely closed, the interior lights will remain illuminated as a result. However, several lights are automatically turned off by the battery drainage prevention function to prevent the battery from going dead. The following interior lights are affected by this function.

Item	Switch position	Automatically turning off
Map lights	OFF*1	Approximately 20 minutes later
Dome lights	DOOR	Approximately 20 minutes later
Ignition switch light	—	Approximately 20 minutes later
Door step lights	—	None*2
Cargo area light	DOOR	Approximately 20 minutes later

*1: The map lights can be controlled by the battery drainage prevention function only when the map light switches are in the OFF position and the door interlock switch is in the DOOR position. For the switch positions, refer to “Map light” 6-2.

*2: The door step lights are not affected by the battery drainage prevention function, so the

lights do not turn off automatically. To turn off the lights, it is necessary that each door is completely closed.

The operational/non-operational setting of this function can be changed by a SUBARU dealer. Contact the nearest SUBARU dealer if you would like to change the setting.

NOTE

- The factory setting (default setting) for this function is set as “operational”.
- When leaving the vehicle, please make sure that all doors and the rear gate (Outback) are completely closed.
- The battery drainage prevention function does not operate while the key is in the ignition switch.

Power door locking switches

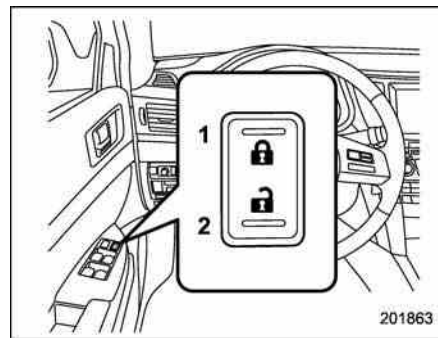

- 1) Lock
- 2) Unlock

All doors and the rear gate (Outback) can be locked and unlocked by the power door locking switches located at the driver's side and the front passenger's side doors.

To lock the doors, press the front side of the switch.

To unlock the doors, press the rear side of the switch.

When you close the doors after you set the door locks, the doors remain locked.

NOTE

Make sure that you do not leave the key inside the vehicle before locking the

doors from the outside using the power door locking switches.

■ Key lock-in prevention function

This function prevents the doors from being locked with the key still in the ignition switch.

▼ Behavior with key lock-in prevention function operational

With the driver's door open, the doors are automatically kept unlocked even if the front side of the power door locking switch is pressed.

▼ Behavior with key lock-in prevention function non-operational

- If the lock lever is turned to the rear ("LOCK") position with the driver's door open and the driver's door is then closed with the lock lever in that position, the driver's door is locked.
- If the spare key is used to lock the driver's door from the outside of the vehicle, the door is locked.

This function's operational/non-operational setting can be changed by a SUBARU dealer. Contact a SUBARU dealer for details.

NOTE

- The factory setting (default setting) for this function is set as "operational".
- When leaving the vehicle, make sure you are holding the key before locking the doors.

Remote keyless entry system



CAUTION

- Do not expose the remote transmitter to severe shocks, such as those experienced as a result of dropping or throwing.
- Do not take the remote transmitter apart except when replacing the battery.
- Do not get the remote transmitter wet. If it gets wet, wipe it dry with a cloth immediately.
- When you carry the remote transmitter on an airplane, do not press the button of the remote transmitter while in the airplane. When any button of the remote transmitter is pressed, radio waves are sent and may affect the operation of the airplane. When you carry the remote transmitter in a bag on an airplane, take measures to prevent the buttons of the remote transmitter from being pressed.
- **FCC WARNING**
Changes or modifications not expressly approved by the party responsible for compliance

could void the user's authority to operate the equipment.

This device complies with Part 15 of the FCC Rules and RSS-Gen of IC Rules. Operation is subject to the following two conditions: (1) This device may not cause harmful interference, and (2) this device must accept any interference received, including interference that may cause undesired operation.

The transmitter for the remote keyless entry system is located inside the key head.

The remote keyless entry system has the following functions.

- Locking and unlocking the doors (and rear gate (Outback)) without a key
- Opening the trunk lid (Legacy) without key
- Sounding a panic alarm
- Arming and disarming the alarm system. For detailed information, refer to "Alarm system" 2-15.

The operable distance of the remote keyless entry system is approximately 30 feet (10 meters). However, this distance will vary depending on environmental conditions. The system's operable dis-

tance will be shorter in areas near a facility or electronic equipment emitting strong radio waves such as a power plant, broadcast station, TV tower, or remote controller of home electronic appliances.

NOTE

The remote keyless entry system does not operate when the key is inserted in the ignition switch.

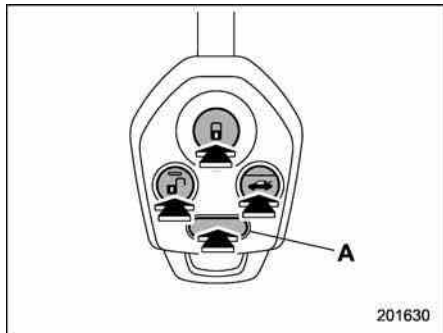

- : Trunk lid/rear gate unlock button
- : Unlock/disarm button
- : Lock/arm button
- A: Panic button

Locking the doors

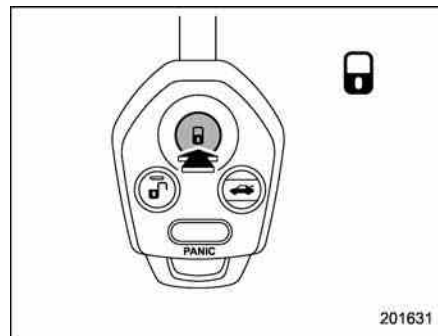



Press the "L" button to lock all doors and rear gate (Outback). An electronic chirp will sound once and the turn signal lights will flash once.

If any of the doors (or the rear gate/trunk lid) is not fully closed, an electronic chirp will sound five times and the turn signal lights will flash five times to alert you that the doors (or the rear gate/trunk lid) are not properly closed. When you close the door, it will automatically lock and then an electronic chirp will sound once and the turn signal lights will flash once.

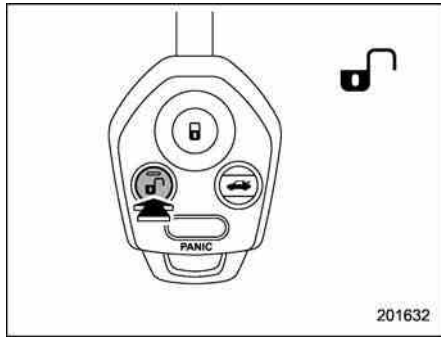
■ Unlocking the doors





Press the “” button to unlock the driver’s door. An electronic chirp will sound twice and the turn signal lights will flash twice. To unlock all doors and the rear gate (Outback), briefly press the “” button a second time within 5 seconds.

NOTE

If the interval between the first and second presses of the “” button (for unlocking of all of the doors and the rear gate) is extremely short, the system may not respond.

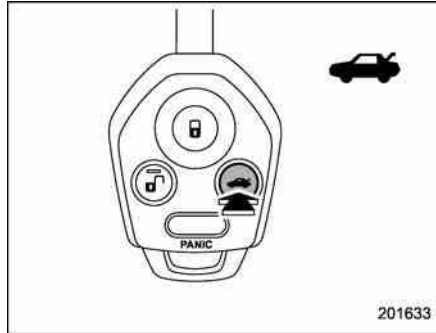
■ Opening the trunk lid (Legacy)



The trunk lid opens when the “” button is pressed continuously for at least 2 seconds. An electronic chirp will sound twice and the turn signal lights will flash twice.

■ Unlocking the rear gate (Outback)

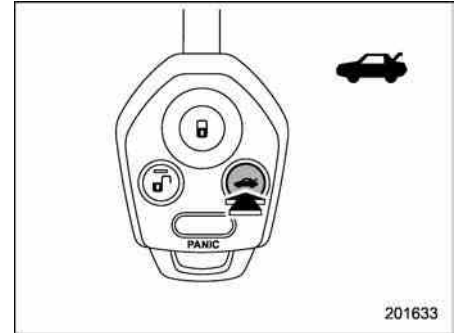

Pressing the “” button unlocks the rear gate.

An electronic chirp will sound twice and the turn signal lights will flash twice.

■ Vehicle finder function

Use this function to find your vehicle parked among many vehicles in a large parking lot. Provided you are within 30 feet (10 meters) of the vehicle, pressing the “” button three times in a 5-second period will cause your vehicle’s horn to sound once and its turn signal lights to flash three times.

NOTE

If the interval between presses is too short when you press the “” button three times, the system may not respond to the signals from the remote transmitter.

■ Sounding a panic alarm

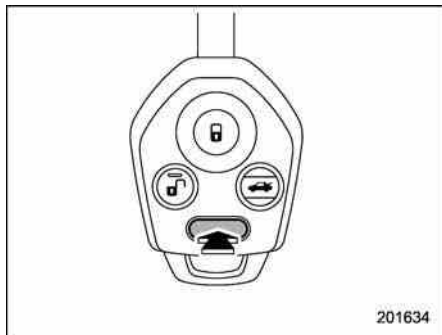

To activate the alarm, press the “PANIC” button once.

The horn will sound and the turn signal lights will flash.

To deactivate the panic alarm, press any button on the remote transmitter. If a button on the remote transmitter is not pressed, the alarm will be deactivated after approximately 30 seconds.

■ Selecting audible signal operation

Using an electronic chirp, the system will give you an audible signal when the doors lock and unlock. If desired, you may turn the audible signal off.

To deactivate the audible signal, perform the following procedure. You can also use the same steps to restore the function.

1. Sit in the driver's seat and shut all doors and the rear gate.
2. Press the unlock side of the power door locking switch.
3. Insert the key into the ignition switch.
4. While holding down the unlock side of the power door locking switch, pull the key out and re-insert it into the ignition switch at least 5 times within 10 seconds after performing step 2.
5. Open and close the driver's door within 10 seconds after performing step 4.
6. To indicate completion of the setting, the turn signal lights flash 3 times and the chirp sounds 3 times.

You may have the above procedure performed by your SUBARU dealer.

■ Replacing the battery



- Do not let dust, oil or water get on or in the transmitter when replacing the battery.
- Be careful not to damage the printed circuit board in the transmitter when replacing the battery.
- Be careful not to allow children to touch the battery and any removed parts; children could swallow them.
- There is a danger of explosion if an incorrect replacement battery is used. Replace only with the same or equivalent type of battery.
- Batteries should not be exposed to excessive heat such as sunshine, fire or the like.

If the transmitter fails to operate when used within the standard distance, this may indicate a weak battery. Replace the battery as soon as possible. The battery can be replaced by your authorized SUBARU dealer. If you replace the battery by yourself, use utmost care that no dust, oil or water enters the transmitter.

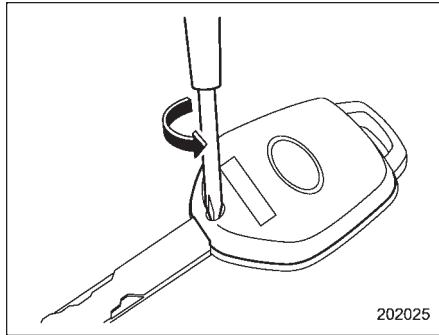
To replace the battery:

1. Remove the screw on the key head.

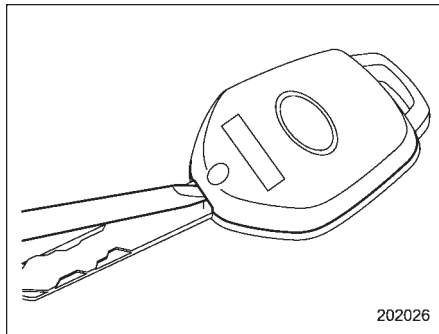

2. Open the key head using a flat-head screwdriver.

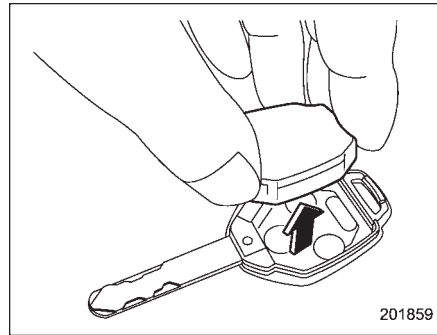

3. Remove the transmitter case from the key head.

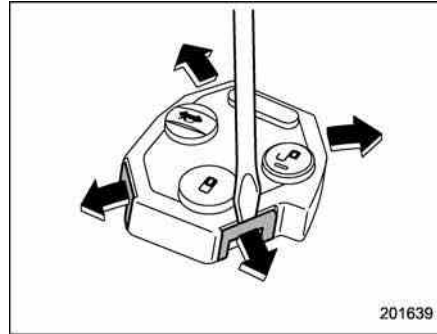

4. Open the transmitter case by releasing the hooks.

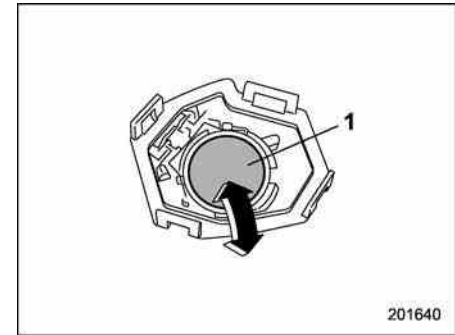

1) Negative (-) side facing up

5. Replace the old battery with a new battery (Type CR1620 or equivalent) making sure to install the new battery with the negative (-) side facing up.

6. Put together the transmitter case by fitting the hooks on the case.

7. Reinstall the transmitter case in the key head.

8. Reinstall the screw on the key head.

After the battery is replaced, the transmitter must be synchronized with the remote keyless entry system's control unit. Press either the "⏏" or "⏏" button six times to synchronize the unit.

■ Replacing lost transmitters

If you lose a transmitter or want to purchase additional transmitters (up to four can be programmed), you should re-program all of your transmitters for security reasons. It is recommended that you have your dealer program all of your transmitters into your system.

▼ Programming the transmitters

The remote keyless entry system is equipped with a special code learning feature that allows you to program new transmitter codes into the system or to delete old ones. The system can learn up to four unique transmitter codes. The four transmitter codes may be the same or different.

Programming transmitter codes into system:

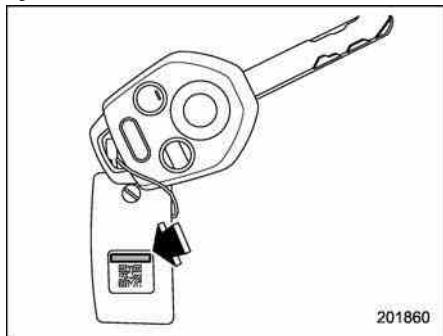

Key unit tag

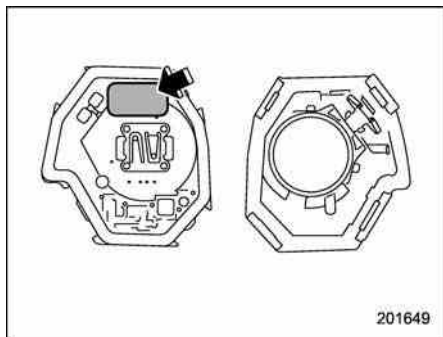

Transmitter circuit board

To register a new transmitter with the remote keyless entry system, it is neces-

sary to program the transmitter's code (identification number) into the system. A tag showing the code is affixed to the key unit, and another is affixed to the circuit board inside the transmitter. If there is no tag, open the transmitter case and make a note of the eight-digit number. Program the number into the system in accordance with the following procedure.

1. Firmly close the doors and the rear gate (Outback) or trunk lid (Legacy).
2. Open the driver's door, sit in the driver's seat, and close the door.
3. Perform the following steps within 45 seconds.

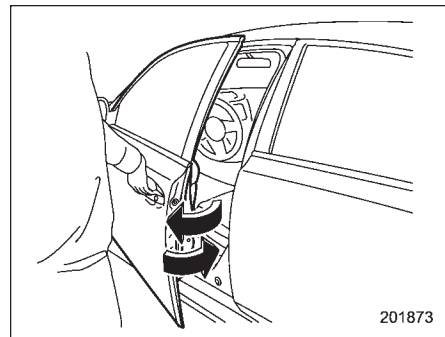

- (1) Open and close the driver's door once.

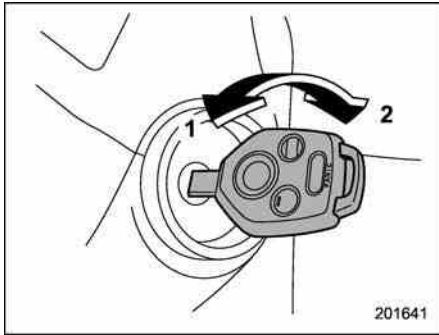

- 1) LOCK
- 2) ON

(2) Insert the key into the ignition switch, then turn it from the "LOCK" position to the "ON" position 10 times within 15 seconds.

NOTE

- When you complete step (2), an electronic tone will sound once.
 - If you do not perform steps (1) and (2) within 45 seconds, an error will occur. An electronic tone will not sound. In this event, perform the whole procedure again beginning with part 1.
4. Open and close the door once within 15 seconds.

NOTE

- When part 4 of the procedure is completed, an electronic tone will sound for 30 seconds.
- If you do not perform the operations in part 4 within 15 seconds, an error will occur and the electronic tone will not sound. In this event, perform the registration steps again beginning with part 3 of the procedure.

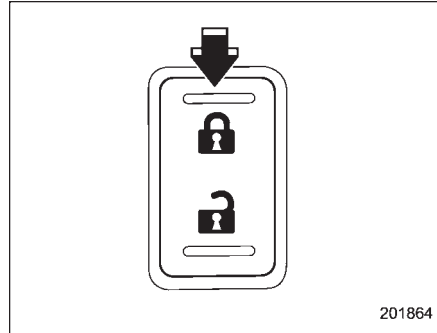

5. Before the electronic tone stops sounding, press the lock side of the power door lock switch the same number of times as the leftmost digit of the transmitter code. For example, press the lock switch eight times if the leftmost digit of the code is 8.

NOTE

- The electronic tone will stop sounding when you start entering the number.
- If you do not start entering the number using the lock switch before the electronic tone stops sounding, an error will occur. In this event, perform the registration steps again beginning with part 3 of the procedure.
- If the interval between one press of the switch and the next exceeds 5 seconds, an error will occur. In this event, perform the procedure again beginning with part 4. If an error occurs six times, perform the procedure again starting with part 3.

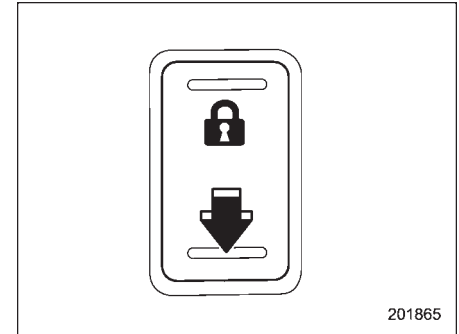

6. When you have finished entering the number, press the unlock side of the lock

switch within 5 seconds.

NOTE

- An electronic tone will sound.
- If you press the unlock side of the lock switch when more than 5 seconds have passed, an error will occur. In this event, perform the procedure again beginning with part 4. If an error occurs six times, perform the procedure again starting with part 3.

7. Perform parts 5 and 6 of the procedure for each of the remaining digits of the transmitter code beginning with the second digit (counting from the left) and finishing with the eighth digit.

NOTE

- When you finish entering the eighth digit, an electronic tone will sound for 30 seconds.
- If the interval between one press of the switch and the next exceeds 5 seconds, an error will occur. In this event, perform the procedure again beginning with part 4. If an error occurs six times, perform the procedure again starting with part 3.

8. Before the electronic tone stops sounding, use the power door lock switch to reenter the transmitter code beginning with the leftmost digit.

NOTE

If you do not start entering the number using the lock switch before the electronic tone stops sounding, an error will occur. In this event, perform the procedure again beginning with part 3.

9. When you have finished entering the code a second time, an electronic tone will sound for 1 second to indicate completion of registration, provided the code entered the second time is identical to that entered the first time.

NOTE

If the code entered the second time is not identical to the code entered the first time, an error will occur. In this event, perform the procedure again beginning with part 5. If an error occurs five times, perform the procedure again starting with part 3.

10. If you wish to program another transmitter code into the system (up to four transmitter codes can be programmed into the system), perform the procedure beginning with part 4. When you have finished programming all of the necessary transmitter codes into the system, remove the key from the ignition switch.

11. Test every registered transmitter to confirm correct operation.

▼ Deleting old transmitter codes

The control unit of the remote keyless entry system has four memory locations to store transmitter codes, giving it the ability to operate with up to four transmitters. When you lose a transmitter, the lost transmitter's code remains in the memory. For security reasons, lost transmitter codes should be deleted from the memory.

To delete old transmitter codes, program four transmitter codes into the system. If you have only one current transmitter, program it four times. If you have two current transmitters, program each one twice. If you have three current transmitters, program two of them once and the third one twice. This process will leave only current transmitter codes in the system's memory.

NOTE

Make sure no one else is operating their remote keyless entry system within range of your vehicle when programming transmitters. If someone else were to operate their remote transmitter while you are programming your transmitters, it is possible that their transmitter code will be programmed into your system, allowing them unauthorized access to your vehicle.

Alarm system

The alarm system helps to protect your vehicle and valuables from theft. The horn sounds and the turn signal lights flash if someone attempts to break into your vehicle.

The system can be armed and disarmed with the remote transmitter.

The system does not operate when the key is inserted into the ignition switch.

Your vehicle's alarm system has been set for activation at the time of shipment from the factory. You can set the system for deactivation yourself or have it done by your SUBARU dealer.

■ System alarm operation

The alarm system will give the following alarms when triggered:

- The vehicle's horn will sound and the turn signal lights will flash for 30 seconds.
- If any door (or the rear gate/trunk lid) remains open after the 30-second period, the horn will continue to sound for a maximum of 3 minutes. If the door (or the rear gate/trunk lid) is closed while the horn is sounding, the horn will stop sounding with a delay of up to 30 seconds.

The alarm is triggered by:

- Opening a door, the rear gate or trunk lid
- Physical impact to the vehicle, such as forced entry (only models with shock sensors (dealer option))

NOTE

The alarm system can be set to trigger illumination of map lights and dome light. The map lights and dome light notification is deactivated as the factory setting. Refer to "Function settings" 20. A SUBARU dealer can activate the system. Contact your SUBARU dealer for details.

■ Activating and deactivating the alarm system

To change the setting of your vehicle's alarm system for activation or deactivation, do the following.

1. Disarm the alarm system. Refer to "Disarming the system" 2-17.
2. Sit in the driver's seat and shut all doors (and the rear gate (Outback)).
3. Turn the ignition switch to the "ON" position.
4. Hold down the REAR (UNLOCK) side of the driver's power door locking switch, open the driver's door within the following

1 second, and wait 10 seconds without releasing the switch. The setting will then be changed as follows:

If the system was previously activated:

The trip meter screen displays "AL OFF" and the horn sounds twice, indicating that the system is now deactivated.

If the system was previously deactivated:

The trip meter screen displays "AL on" and the horn sounds once, indicating that the system is now activated.

NOTE

You may have the above setting change done by your SUBARU dealer.

■ If you have accidentally triggered the alarm system

▼ To stop the alarm

Perform any of the following operations.

- Press any button on the remote transmitter.
- Turn the ignition switch to the "ON" position.

■ Arming the system

▼ To arm the system using remote transmitter

1. Close all windows and the moonroof (if equipped).
2. Remove the key from the ignition switch.
3. Open the doors and get out of the vehicle.
4. Make sure that the engine hood (and the trunk lid (Legacy)) are locked.
5. Close all doors (and the rear gate (Outback)).

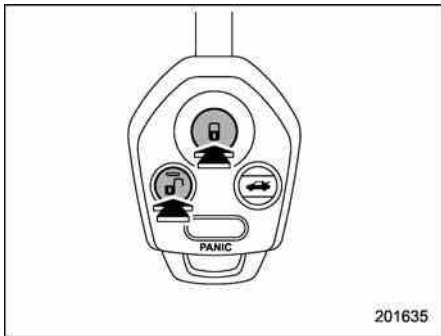

- 🔒 : Press to Arm the system.
- 🔓 : Press to Disarm the system.

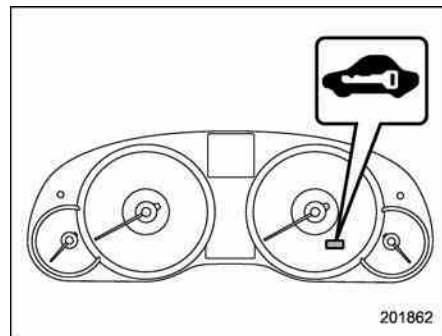

Security indicator light

6. Briefly press the "🔒" button (for less than 2 seconds). All doors (and the rear gate (Outback)) will lock, an electronic chirp will sound once, the turn signal lights will flash once, and the security indicator light will start flashing rapidly. After rapid flashing for 30 seconds (standby time), the security indicator light will then flash slowly (twice approximately every 2 seconds), indicating that the system has been armed for surveillance.

If any of the doors (rear gate or trunk lid) is not fully closed, an electronic chirp sounds five times, the turn signal lights flash five times to alert you that the doors (or the rear gate) are not properly closed. When you close the door, the system will automatically arm and doors will automa-

tically lock.

▼ **To arm the system using power door locking switch**

1. Close all windows.
2. Remove the key from the ignition switch.
3. Open the doors and get out of the vehicle.
4. Make sure that the engine hood is locked.
5. Close the doors (and the rear gate (Outback)) but leave only the driver's door or the front passenger's door open.

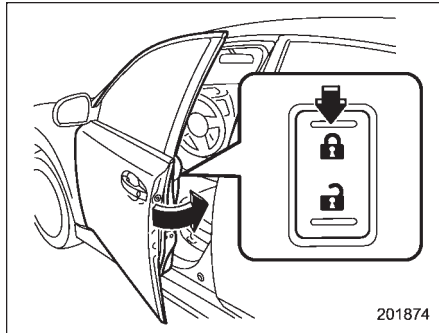

6. Press the front side ("LOCK" side) of the power door locking switch to set the door locks.
7. Close the door. An electronic chirp will sound once, the turn signal lights will flash

once and the security indicator light will start flashing rapidly. After rapid flashing for 30 seconds (standby time), the security indicator light will then flash slowly (twice approximately every 2 seconds), indicating that the system has been armed for surveillance.

NOTE

- **The system can be armed even if the engine hood, the windows and/or moonroof are open. Always make sure that they are fully closed before arming the system.**
- **The 30-second standby time can be eliminated if you prefer. Have it performed by your SUBARU dealer.**
- **If your vehicle is a Legacy and you open the trunk using the remote transmitter's "🚗" button with the alarm system armed, the system will be temporarily placed in a standby state. The system will go back to the surveillance state upon locking the trunk.**
- **The system is in the standby mode for a 30-second period after locking the doors with the remote transmitter. The security indicator light will flash at short intervals during this period.**
- **If any of the following actions is done during the standby period, the system will not switch to the surveil-**

lance state.

- **Doors are unlocked using the remote transmitter.**
- **Any door (including the rear gate (Outback) or the trunk (Legacy)) is opened.**
- **Ignition switch is turned to the "ON" position.**

■ Disarming the system

Briefly press the "🔓" button (for less than 2 seconds) on the remote transmitter. The driver's door will unlock, an electronic chirp will sound twice, the turn signal lights will flash twice and the security indicator light will turn off.

To unlock all other doors and the rear gate (Outback), briefly press the "🔓" button a second time within 5 seconds.

▼ Emergency disarming

If you cannot disarm the system using the transmitter (i.e. the transmitter is lost, broken or the transmitter battery is too weak), you can disarm the system without using the transmitter.

The system can be disarmed if you turn the ignition switch from the "LOCK" to the "ON" position with a registered key.

■ Valet mode

When you choose the valet mode, the alarm system does not operate. In valet mode, the remote transmitter is used only for locking and unlocking the doors and rear gate (Outback) and panic activation.

To enter the valet mode, change the setting of your vehicle's alarm system for deactivation mode. Refer to "Activating and deactivating the alarm system" 2-15. The security indicator light will continue to flash once every 3 seconds indicating that the system is in the valet mode.

To exit valet mode, change the setting of your vehicle's alarm system for activation mode. Refer to "Activating and deactivating the alarm system" 2-15.

■ Passive arming

When passive arming mode has been programmed by the dealer, arming of the system is automatically accomplished without using the remote transmitter. Note that in this mode, **DOORS MUST BE MANUALLY LOCKED.**

▼ To enter the passive mode

If you wish to program the passive arming mode, have it done by your SUBARU dealer.

▼ Arming the system

▲ CAUTION

In passive mode, the system will automatically activate the alarm but WILL NOT automatically lock the doors. In order to lock the doors you must either lock them as indicated in step 4 below or with the key once they have been closed. Failure to lock the doors manually will result in a higher security risk.

1. Turn the ignition switch to the "ON" position.

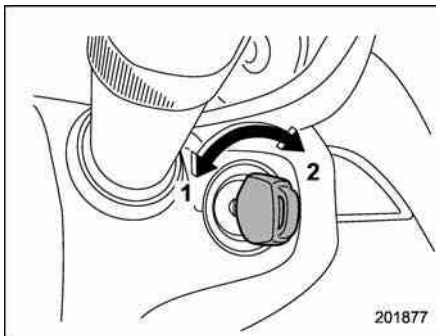

- 1) LOCK
- 2) ON

2. Turn the ignition switch from "ON" to

"LOCK" position and remove the key from the ignition switch.

3. Open the doors and get out of the vehicle.

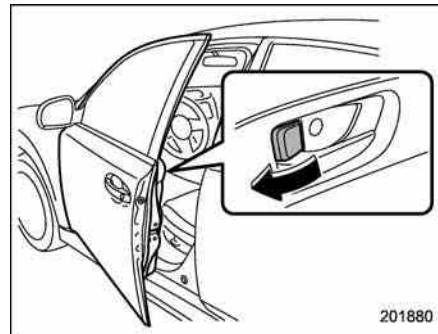

4. Before closing the doors, lock all doors with the inside door lock levers.
5. Close the doors. The system will automatically arm after 1 minute.

In the passive mode, the system can also be armed with the remote transmitter or with the power door locking switches. If the remote transmitter or power door locking switch is used to lock the vehicle, arming will take place immediately regardless of whether or not the passive mode has been selected.

▼ Disarming the system

To disarm the system, briefly press the “” button on the transmitter.

■ Tripped sensor identification

The security indicator light flashes when the alarm system has been triggered. Also, the number of flashes indicates the location of unauthorized intrusion or the severity of impact on the vehicle.

When the ignition switch is turned to the “ON” position, the indicator light will illuminate for 1 second and then flash as follows:

- When a door or rear gate (Outback) was opened: 5 times
- When the trunk (Legacy) was opened: 4 times
- When a strong impact or multiple impacts were sensed: twice (only models with shock sensors (dealer option))
- When a light impact was sensed: once (only models with shock sensors (dealer option))

■ Shock sensors (dealer option)

The shock sensors trigger the alarm system when they sense impacts applied to the vehicle and when any of their electric wires is cut. The alarm system

causes the horn to sound and the turn signal lights to flash for a short time when the sensed impact is weak, but it warns of a strong impact or multiple impacts by sounding the horn and flashing the turn signal lights, both lasting approximately 30 seconds.

If you desire, your SUBARU dealer can connect them and set them for activation or deactivation.

NOTE

- **The shock sensors are not always able to sense impacts caused by breaking in, and cannot sense an impact that does not cause vibration (such as breaking the glass using a rescue hammer).**
 - **The shock sensors may sense vibration like those shown in the following and trigger the alarm system. Select the settings of the alarm system and shock sensors appropriately depending on where you usually park your vehicle.**
- Examples:

- Vibration from construction site
- Vibration in multistory car park
- Vibration from trains
- **You can have the sensitivity of the shock sensors adjusted to your preference by your SUBARU dealer.**

Child safety locks



WARNING

Always turn the child safety locks to the “LOCK” position when children sit on the rear seat. Serious injury could result if a child accidentally opens the door and falls out.

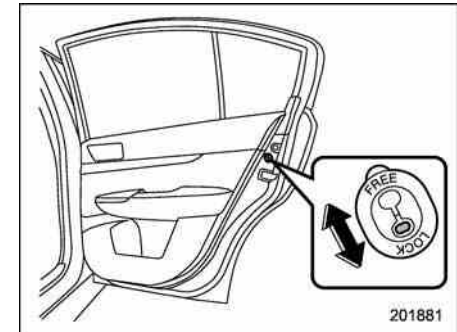

Each rear door has a child safety lock that prevents the door from being opened even if the inside door handle is pulled.

When the child safety lock lever is in the “LOCK” position, the door cannot be opened from inside regardless of the position of the inner door handle lock lever. The door can only be opened from

the outside.

Windows

⚠ WARNING

To avoid serious personal injury caused by entrapment, always conform to the following instructions without exception.

- When operating the power windows, be extremely careful to prevent anyone's fingers, arms, neck, head or other objects from being caught in the window.
- Always lock the passengers' windows using the lock switch when children are riding in the vehicle.
- Before leaving the vehicle, always remove the key from the ignition switch for safety and never allow an unattended child to remain in the vehicle. Failure to follow this procedure could result in injury to a child operating the power window.

The power windows operate only when the ignition switch is in the "ON" position.

■ Power window operation by driver

▼ Driver's side power window switches

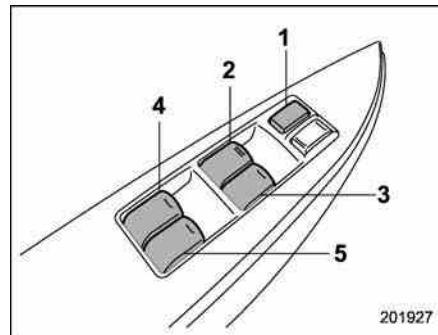

- 1) Lock switch
- 2) For driver's window
- 3) For front passenger's window
- 4) For rear left passenger's window
- 5) For rear right passenger's window

All door windows can be controlled by the power window switch cluster at the driver side door.

▼ Operating the driver's window

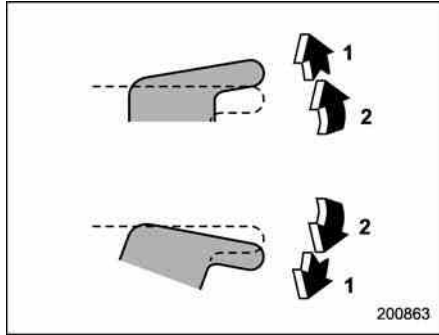

- 1) Automatically open/close
- 2) Open/close

To open:

Press the switch down lightly and hold it. The window will open as long as the switch is held.

This switch also has a one-touch auto down function that allows the window to be opened fully without holding the switch.

Press the switch down until it clicks and release it, and the window will fully open. To stop the window halfway, pull the switch up lightly.

To close:

Pull the switch up lightly and hold it. The window will close as long as the switch is held.

For some models, this switch also has a one-touch auto up function that allows the window to be closed fully without holding the switch.

Pull the switch up until it clicks and release it, and the window will fully close. To stop the window halfway, press the switch down lightly.

NOTE

If the vehicle's battery is disconnected due to situations such as battery or fuse replacement, the one-touch auto up/down function is deactivated. Initialize the power window to reactivate the one-touch auto up/down function. Refer to "Initialization of power window" 2-23.

▼ Anti-entrapment function (driver's door) (models with one-touch auto up function)

⚠ CAUTION

- Never attempt to test this function using fingers, hands or other parts of your body.
- The anti-entrapment function may not operate properly if some object gets trapped just before the window fully closes.

NOTE

- If a window detects an impact similar to that caused by trapping an object (for example, when the vehicle encounters a deep pothole), the anti-entrapment function may operate.
- The window cannot be operated for a few seconds after the anti-entrapment function operates.
- If the vehicle's battery is disconnected due to situations such as battery or fuse replacement, the anti-entrapment function is deactivated. Initialize the power window to reactivate the anti-entrapment function. Refer to "Initialization of power window" 2-23.

While closing with the one-touch auto up function, if the window senses a substantial enough object trapped between the window and the window frame, it automatically moves down slightly and stops.

▼ Operating the passengers' windows

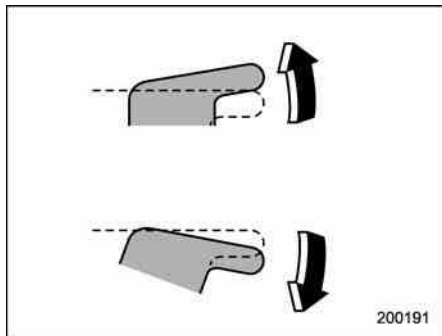

To open:

Press the appropriate switch down and hold it until the window reaches the desired position.

To close:

Pull the switch up and hold it until the window reaches the desired position.

▼ Locking the passengers' windows

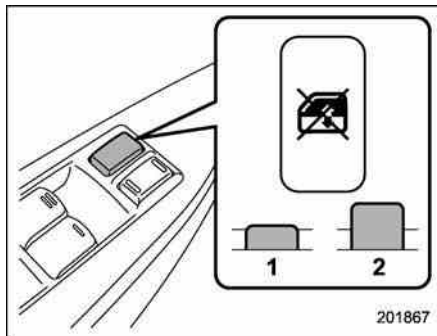

- 1) Lock
- 2) Unlock

To lock:

Press the lock switch. When the lock switch is in the lock position, the passengers' windows cannot be opened or closed.

To unlock:

Press the lock switch again.

■ Power window operation by passengers

▼ Passenger's side power window switches

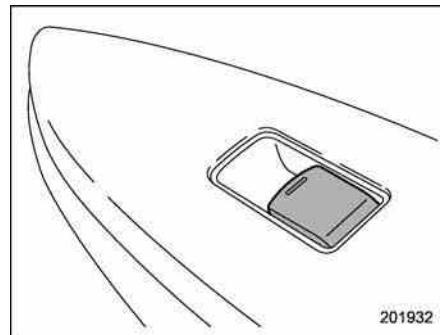

Each passenger window can be controlled by the power window switch located on the door.

▼ Operating the windows

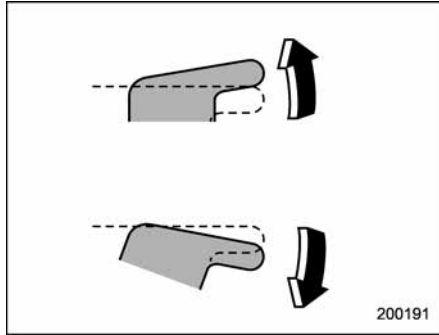

To open:

Press the switch down and hold it until the window reaches the desired position.

To close:

Pull the switch up and hold it until the window reaches the desired position.

When the lock switch on the power window switch cluster, located on the driver's side door, is in the lock position, the passengers' windows cannot be operated with the passengers' switches.

■ Initialization of power window

If the vehicle's battery is disconnected due to situations such as battery or fuse replacement, the following functions are deactivated.

- One-touch auto up/down function
- Anti-entrapment function (if equipped)

Initialize the power window in the following procedure to reactivate such functions.

1. Close the driver's door.
2. Turn the ignition switch to the "ON" position.
3. Open the driver's side window halfway by pushing down the power window switch.
4. Pull up the power window switch and close the window completely. Continue pulling up the switch for approximately 1 second after the window is closed completely.

Trunk lid (Legacy)



WARNING

- To prevent dangerous exhaust gas from entering the vehicle, always keep the trunk closed while driving.
- Help prevent children, adults or animals from locking themselves in the trunk. On hot or sunny days, the temperature in the trunk could quickly become high enough to cause death or serious heat-related injuries including brain damage to anyone locked inside, particularly for small children.
- When leaving the vehicle, close all windows and lock all doors. Also make certain that the trunk is closed.

■ To open and close the trunk lid from outside

The trunk lid can be opened using the remote keyless entry system. Refer to "Opening the trunk lid (Legacy)" 2-9.

To close the trunk lid, lightly press the

trunk lid down until the latch engages.

NOTE

- Do not leave your valuables in the trunk when you leave your vehicle.
- Even when the trunk lid cannot be opened using the remote keyless entry system, you can open the trunk lid by using the key. Refer to “Trunk lid (Legacy) – if the trunk lid cannot be opened” 9-19.

■ To open the trunk lid from inside

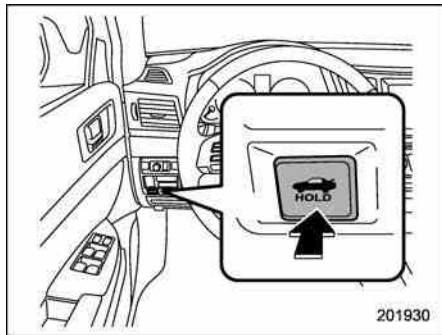

Press the trunk lid opener switch for more than 1 second.

▼ To lock and unlock the trunk lid opener switch

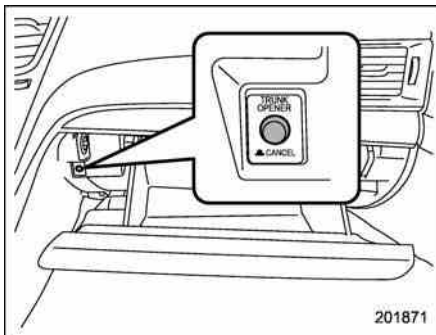

When you entrust your vehicle key to another person, you can lock the trunk lid opener switch to prevent items in the trunk from being stolen.

To lock the trunk lid opener switch, perform the following procedure.

1. Open the glove box. Refer to “Glove box” 6-6.
2. Press the trunk lid opener lock button.

To unlock the trunk lid opener switch, perform the same procedure again.

■ Internal trunk lid release handle

The internal trunk lid release handle is a device designed to open the trunk lid from inside the trunk. In the event children or adults become locked inside the trunk, the handle allows them to open the lid. The handle is located on the inside of the trunk lid.

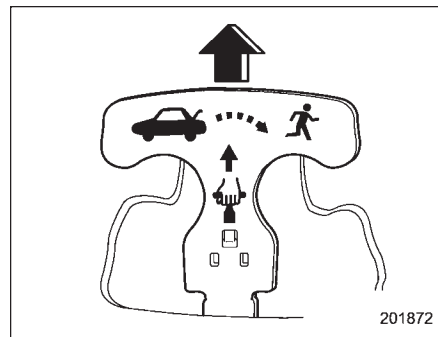

To open the trunk lid from inside the trunk, pull the yellow handle as indicated by the arrow on the handle. This operation unlocks the trunk lid. Then, push up the lid.

The handle is made of material that remains luminescent for approximately an hour in the dark trunk space after it is exposed to ambient light even for a short time.

⚠ WARNING

Never allow any child to get in the trunk and play with the release handle. If the driver starts the vehicle without knowing that a child is inside the trunk and the child opens the lid using the release handle, the child could fall out and be killed or seriously injured.

⚠ CAUTION

- Do not close the lid while gripping the release handle. The handle may be damaged.
- Do not use the handle as a hook to fasten straps or ropes to secure your cargo in the trunk. Such use may result in damage of the handle.
- Load the trunk so that cargo cannot strike the release handle. If the cargo hits the handle while the vehicle is being driven, the handle may be pulled and the trunk lid may open. That may cause cargo to fall out of the trunk, which could create a traffic safety hazard.

▼ Inspection

Perform the following steps at least twice a year to check the release handle for correct operation.

1. Open the trunk lid.

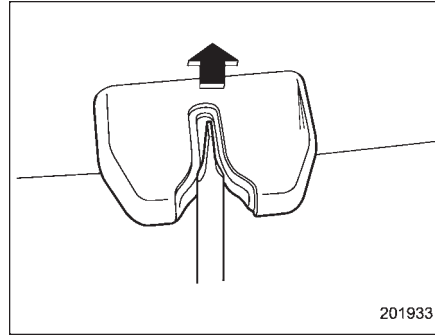

2. Use a flat-head screwdriver with a thin blade. Slide the flat-head screwdriver blade from the slit aperture of the lock assembly fully to the end until you hear a click.

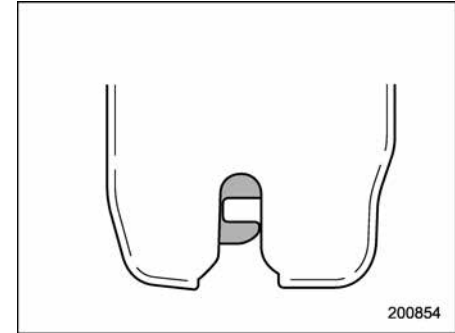

This places the latch in the locked position.

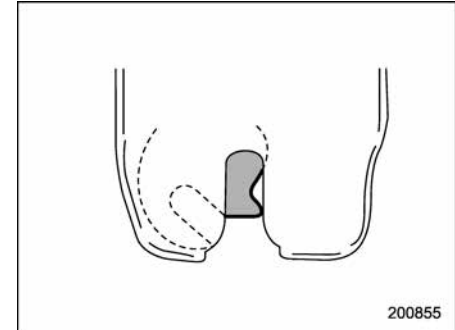

3. Move the release handle, from outside the vehicle, in the direction of the arrow to check if the latch is released.

If the latch is not released, contact your SUBARU dealer.

In that case, use the key to release the latch, then close the trunk lid.

Also, if the movement of the release handle feels restricted or not entirely smooth during operation, or the handle and/or handle base is cracked, contact your SUBARU dealer.

Rear gate (Outback)

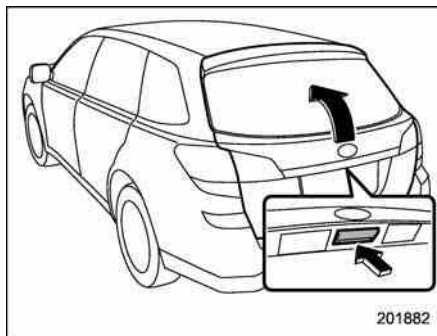

The rear gate can be locked and unlocked using any of the following systems.

- Power door locking switch: Refer to "Power door locking switches" 2-6.
- Remote keyless entry system: Refer to "Remote keyless entry system" 2-7.

To open:

First unlock the rear gate lock then push the rear gate opener button.

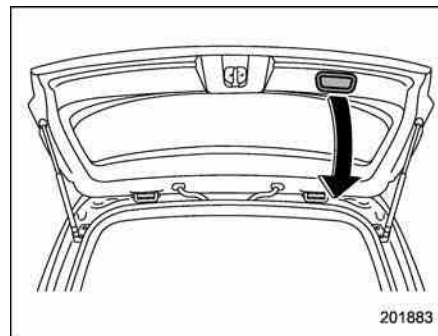

To close:

Lower the rear gate slowly and push down firmly until the latch engages.

The rear gate can be lowered easily if you pull it down holding the recessed grip.

**WARNING**

- To prevent dangerous exhaust gas from entering the vehicle, always keep the rear gate closed while driving.
- Do not attempt to shut the rear gate while holding the recessed grip. Also avoid closing the rear gate by pulling on the recessed grip from inside the cargo space. There is a danger of your hand being caught and injured.

**CAUTION**

- Do not jam a plastic bag in or place cellophane tape on the rear gate stays or scratch the stays while loading or unloading cargo. That could cause leakage of gas from the stays, which may result in their inability to hold the rear gate open.
- Be careful not to hit your head or face on the rear gate when opening or closing the rear gate and when loading or unloading cargo.

NOTE

If the rear gate cannot be unlocked due to a discharged vehicle battery, a malfunction in the door locking/unlocking system or other causes, you can unlock it by manually operating the rear gate lock release lever. For the procedure, refer to “Rear gate (Out-back) – if the rear gate cannot be unlocked” 9-20.

Moonroof (if equipped)**WARNING**

Never let anyone’s hands, arms, head or any objects protrude from the moonroof. A person could be seriously injured if the vehicle stops suddenly or turns sharply or if the vehicle is involved in an accident.

To avoid serious personal injury caused by entrapment, you must conform to the following instructions without exception.

- Before closing the moonroof, make sure that no one’s hands, arms, head or other objects will be accidentally caught in the moonroof.
- Before leaving the vehicle, always remove the key from the ignition switch for safety and never allow an unattended child to remain in the vehicle. Failure to follow this procedure could result in injury to a child operating the moonroof.

- Never try to check the anti-entrapment function by deliberately placing part of your body in the moonroof.

CAUTION

- Do not sit on the edge of the open moonroof.
- Do not operate the moonroof if falling snow or extremely cold conditions have caused it to freeze shut.
- The anti-entrapment function does not operate when the moonroof is being tilted down. Be sure to confirm that it is safe to do so before tilting the moonroof down.

The moonroof has both tilting and sliding functions.

The moonroof operates only when the ignition switch is in the "ON" position.

■ Moonroof switches

▼ Tilting moonroof

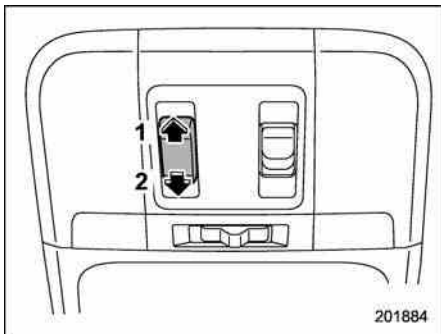

- 1) Raise
- 2) Lower

The raising function will only operate when the moonroof is fully closed. The lowering function will only operate when the moonroof is raised.

Press the rear side of the "UP/DOWN" switch to raise the moonroof.

Press the front side of the "UP/DOWN" switch to lower the moonroof.

Release the switch after the moonroof has been raised or has been lowered completely. Pressing the switch continuously may cause damage to the moonroof.

NOTE

One-touch operation does not take place when the moonroof is lowered. Press the switch continuously to lower the moonroof.

▼ Sliding moonroof

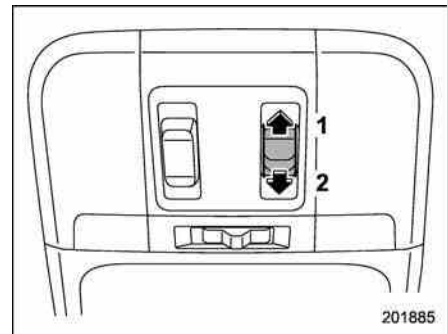

- 1) Open
- 2) Close

Press the "OPEN/CLOSE" switch rearward to open the moonroof. The sun shade will also be opened together with the moonroof. For Outback, the moonroof will stop at a position approximately 0.8 in (2 cm) away from the fully opened position. Press the switch again to open the moonroof completely.

Press the "OPEN/CLOSE" switch forward to close the moonroof.

To stop the moonroof at a selected mid-way position while opening or closing it, momentarily press the switch to the "OPEN" side or "CLOSE" side.

After washing the vehicle or after it rains, wipe away water on the roof prior to opening the moonroof to prevent drops of water from falling into the passenger compartment.

NOTE

- For the sake of safety, it is recommended that you avoid driving with the moonroof fully opened.
- If the moonroof cannot be closed through the switch operation because of system failure, it can be closed manually using a hex-head wrench. For the procedure, refer to "Moonroof – if moonroof cannot be closed" 9-20.

▼ Anti-entrapment function

When the moonroof senses a substantial enough object trapped between its glass and the vehicle's roof during closure, it automatically moves back to the fully open position and stops there. The anti-entrapment function may also be activated by a strong shock on the moonroof even when there is nothing trapped.

⚠ CAUTION

Never attempt to test this function using fingers, hands or other parts of your body.

■ Sun shade

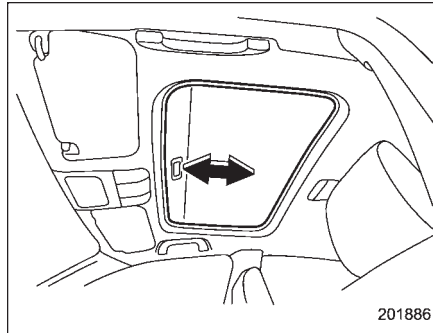

The sun shade can be slid forward or backward by hand while the moonroof is closed.

If the moonroof is opened, the sun shade also moves back.

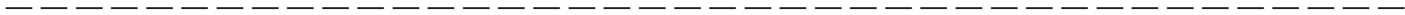
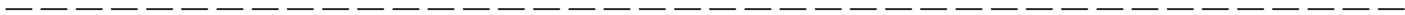
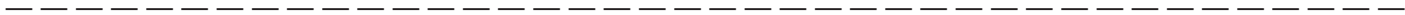
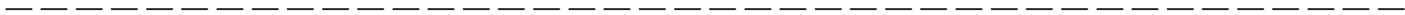
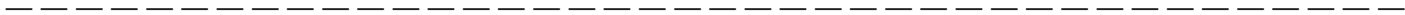

Ignition switch	3-3	AT OIL TEMP warning light (AT and CVT models)	3-14
LOCK.....	3-3	Low tire pressure warning light (U.S. spec. models)	3-15
Acc.....	3-4	ABS warning light.....	3-16
ON.....	3-4	Brake system warning light.....	3-17
START	3-4	Hill Holder indicator light	3-19
Key reminder chime	3-4	Low fuel warning light	3-19
Ignition switch light.....	3-4	Door open indicator light	3-19
Hazard warning flasher.....	3-5	Windshield washer fluid warning light	3-19
Meters and gauges.....	3-5	All-Wheel Drive warning light (AT and CVT models).....	3-20
Combination meter illumination	3-5	Vehicle Dynamics Control warning light/Vehicle Dynamics Control operation indicator light.....	3-20
Canceling the function for meter/gauge needle movement upon turning on the ignition switch.....	3-5	Vehicle Dynamics Control OFF indicator light.....	3-21
Speedometer.....	3-6	Security indicator light.....	3-21
Odometer.....	3-6	Select lever/gear position indicator.....	3-22
Double trip meter	3-6	Turn signal indicator lights.....	3-22
Tachometer.....	3-7	High beam indicator light.....	3-22
Fuel gauge.....	3-7	Cruise control indicator light.....	3-23
ECO gauge	3-8	Cruise control set indicator light	3-23
Warning and indicator lights	3-9	Headlight indicator light.....	3-23
Seatbelt warning light and chime	3-9	Front fog light indicator light (if equipped).....	3-23
SRS airbag system warning light.....	3-11	Clock	3-23
Front passenger's frontal airbag ON and OFF indicators.....	3-11	Multi function display	3-24
CHECK ENGINE warning light/Malfunction indicator light.....	3-12	Outside temperature indicator	3-24
Coolant temperature low indicator light/Coolant temperature high warning light	3-13	Average fuel consumption	3-25
Charge warning light	3-14	Current fuel consumption	3-26
Oil pressure warning light	3-14	Driving range on remaining fuel	3-26
Engine low oil level warning light	3-14	Light control switch.....	3-27
		Headlights	3-27

Instruments and controls

High/low beam change (dimmer).....	3-28
Headlight flasher	3-28
Daytime running light system	3-28
Turn signal lever	3-29
Illumination brightness control	3-29
Front fog light switch (if equipped)	3-30
Wiper and washer	3-30
Windshield wiper and washer switches	3-32
Rear window wiper and washer switch (Outback).....	3-33

Defogger and deicer.....	3-34
Mirrors	3-35
Type A inside mirror (if equipped)	3-35
Type B inside mirror (if equipped)	3-36
Auto-dimming mirror with compass (if equipped)	3-43
Auto-dimming mirror with compass and HomeLink® (if equipped).....	3-45
Outside mirrors	3-50
Tilt/telescopic steering wheel	3-52
Horn.....	3-52

Ignition switch

WARNING

- Never turn the ignition switch to “LOCK” while the vehicle is being driven or towed because that will lock the steering wheel, preventing steering control. And when the engine is turned off, it takes a much greater effort than usual to steer.
- Before leaving the vehicle, always remove the key from the ignition switch for safety and never allow an unattended child to remain in the vehicle. Failure to follow this procedure could result in injury to a child or others. Children could operate the power windows, the moon-roof or other controls or even make the vehicle move.

CAUTION

Do not attach a large key holder or key case to either key. If it banged against your knees or hands while you are driving, it could turn the ignition switch from the “ON” posi-

tion to the “Acc” or “LOCK” position, thereby stopping the engine. Also, if the key is attached to a keyholder or to a large bunch of other keys, centrifugal force may act on it as the vehicle moves, resulting in unwanted turning of the ignition switch.

The ignition switch has four positions: LOCK, Acc, ON and START.

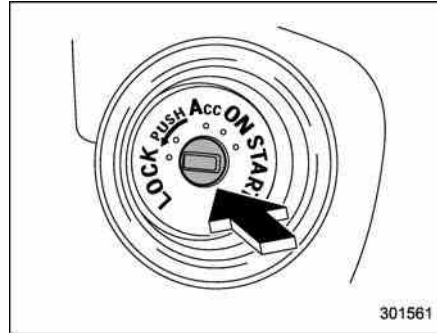

NOTE

- Keep the ignition switch in the “LOCK” position when the engine is not running.
- Using electrical accessories for a long time with the ignition switch in the “ON” or “Acc” position can cause the battery to go dead.

- If the ignition switch will not move from the “LOCK” position to the “Acc” position, turn the steering wheel slightly to the left and right as you turn the ignition switch.

■ LOCK

The key can only be inserted or removed in this position. The ignition switch will lock the steering wheel when you remove the key.

If turning the key is difficult, turn the steering wheel slightly to the right and left as you turn the key.

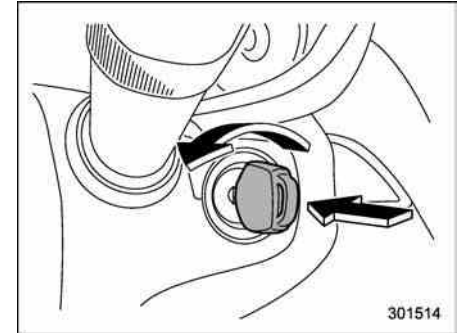

The key can be turned from “Acc” to “LOCK” only when the key is pushed in while turning it (all models) and the select lever is in the “P” position (AT and CVT models).

■ Acc

In this position the electrical accessories (radio, accessory power outlet, etc.) can be used.

■ ON

This is the normal operating position after the engine is started.

■ START

▲ CAUTION

Do not turn the ignition switch to the "START" position while the engine is running.

The engine is started in this position. The starter cranks the engine to start it. When the key is released (after the engine has started), the key automatically returns to the "ON" position.

If the engine does not start with your registered key, pull out the key once (at this time, the security indicator light will blink), wait for at least 10 seconds, reinsert the key in the ignition switch and then try to start the engine again.

NOTE

The engine may not start in the following cases:

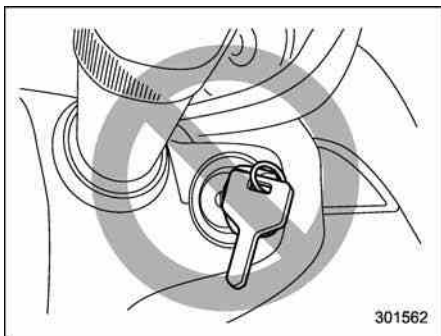

- The key grip is touching another key or a metallic key holder.

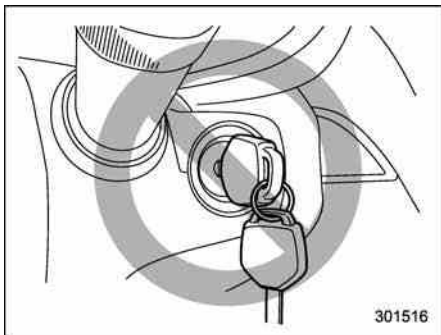

- The key is near another key that contains an immobilizer transponder.
- The key is near or touching another transmitter.

■ Key reminder chime

The reminder chime sounds when the driver's door opens and the key is in the "LOCK" or "Acc" positions. The chime stops when the ignition switch is turned to the "ON" position or the key is removed from the ignition switch.

■ Ignition switch light

For easy access to the ignition switch in the dark, the ignition switch light illuminates when driver's door is opened or when the driver's door is unlocked using the remote keyless entry transmitter.

The light remains illuminated for approximately 30 seconds and gradually turns off under the following conditions.

- When the driver's door is closed
- When the doors are unlocked using the remote keyless entry transmitter

The light gradually turns off under the following conditions.

- When the ignition switch is turned to the "ON" position
- When the doors are locked using the remote keyless entry transmitter

Hazard warning flasher

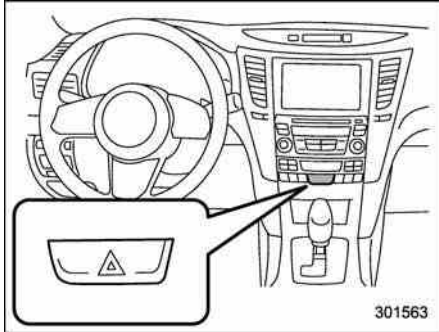

The hazard warning flasher is used to warn other drivers when you have to park your vehicle under emergency conditions. The hazard warning flasher works with the ignition switch in any position.

To turn on the hazard warning flasher, press the hazard warning button on the instrument panel. To turn off the flasher, press the button again.

NOTE

When the hazard warning flasher is on, the turn signals do not work.

Meters and gauges

NOTE

Liquid crystal displays are used in some of the meters and gauges in the combination meter. You will find their indications hard to see if you wear polarized glasses.

■ Combination meter illumination

When the ignition switch is turned to the "ON" position, the various parts of the combination meter are illuminated in the following sequence.

1. Warning lights, indicator lights, meter needles, gauge needles, odometer and trip meter back light illuminate.
2. Meter needles and gauge needles each show MAX position.
3. Meter needles and gauge needles each show MIN position.
4. Dials and indicators in meters and gauges light up.
5. Regular illumination (for driving) begins.

NOTE

The above sequence of operations may not take place if you quickly turn the ignition switch to start the engine. This is not a malfunction.

■ Canceling the function for meter/gauge needle movement upon turning on the ignition switch

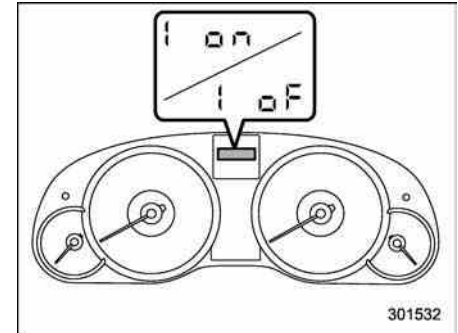

It is possible to activate or deactivate the movement of the meter needles and gauge needles that takes place when the ignition switch is turned to the "ON" position.

1. Turn the ignition switch to the "LOCK" or "Acc" position.
2. Press the trip knob to show "I ON" or "I OFF" on the trip meter display.

The display can be switched as shown in the following illustration by pressing the trip knob.

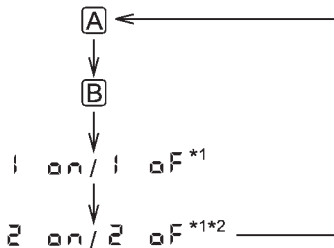

*1: "1 on" or "1 of" and "2 on" or "2 of" cannot be displayed when the ignition switch is in the "ON" position.

*2: MT models only

3. To change the current setting, press the trip knob for at least 2 seconds.

1 on : Activated

1 of : Deactivated

NOTE

- Your vehicle's initial movement setting of the meter/gauge needles has been set for activation "1 on" at the time of shipment from the factory.
- It is not possible to change the initial movement setting of the meter/gauge needles when the ignition switch is in

the "ON" position. Change the setting when the ignition switch is in the "LOCK" or "Acc" position.

■ Speedometer

The speedometer shows the vehicle speed.

■ Odometer

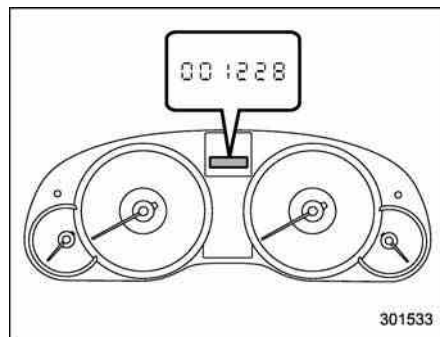

This meter displays the odometer when the ignition switch is in the "ON" position. The odometer shows the total distance that the vehicle has been driven.

If you press the trip knob when the ignition switch is in the "LOCK" or "Acc" position, the odometer/trip meter will light up. If you do not press the trip knob within 10 seconds of illumination of the odometer/

trip meter, the odometer/trip meter will turn off.

Also, if you open and close the driver's door within 10 seconds of illumination of the odometer/trip meter, the odometer/trip meter will turn off.

■ Double trip meter

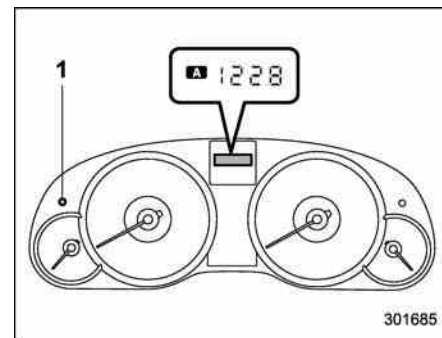

1) Trip knob

This meter displays the two trip meters when the ignition switch is in the "ON" position.

The trip meter shows the distance that the vehicle has been driven since you last set it to zero.

If you press the trip knob when the ignition switch is in the "LOCK" or "Acc" position, the odometer/trip meter will light up. It is

possible to switch between the A trip meter and B trip meter indications while the odometer/trip meter is lit up. If you do not press the trip knob within 10 seconds of illumination of the odometer/trip meter, the odometer/trip meter will turn off.

Also, if you open and close the driver's door within 10 seconds of illumination of the odometer/trip meter, the odometer/trip meter will turn off.

The display can be switched as shown in the following illustration by pressing the trip knob.

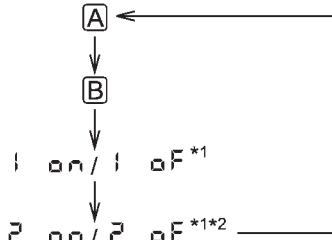

*1: "1 on" or "1 of" and "2 on" or "2 of" cannot be displayed when the ignition switch is in the "ON" position.

*2: MT models only

To set the trip meter to zero, select the A trip or B trip meter by pressing the knob and keep the knob pressed for more than 2 seconds.

CAUTION

To ensure safety, do not attempt to change the function of the indicator during driving, as an accident could result.

NOTE

If the connection between the combination meter and battery is broken for any reason such as vehicle maintenance or fuse replacement, the data recorded on the trip meter will be lost.

Tachometer

The tachometer shows the engine speed in thousands of revolutions per minute.

CAUTION

Do not operate the engine with the pointer of the tachometer in the red zone. In this range, fuel injection will be cut by the engine control module to protect the engine from overrevving. The engine will resume running normally after the engine speed is reduced below the red zone.

NOTE

To protect the engine while the select lever is in the "P" or "N" position (for AT and CVT models) or the shift lever is in the neutral position (for MT models), the engine is controlled so that the engine speed may not become too high even if the accelerator pedal is pressed hard.

Fuel gauge

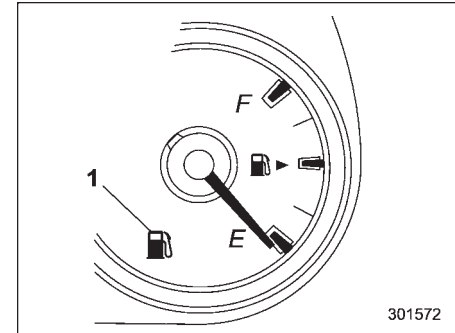

1) Low fuel warning light

The fuel gauge shows the approximate amount of fuel remaining in the tank. When the ignition switch is in the "LOCK" or "Acc" position, the fuel gauge shows "E" even if the fuel tank contains fuel.

The gauge may move slightly during braking, turning or acceleration due to fuel level movement in the tank.

If you press the trip knob while the ignition switch is in the "LOCK" or "Acc" position, the fuel gauge's dial will light up and the needle will indicate the amount of fuel remaining in the tank.

If, while the fuel gauge needle is indicating the amount of fuel remaining in the tank, you (a) do not press the trip knob for 10 seconds or (b) open and close the driver's door, the fuel gauge needle will drop to the "E" position and the dial and needle will turn off.

NOTE

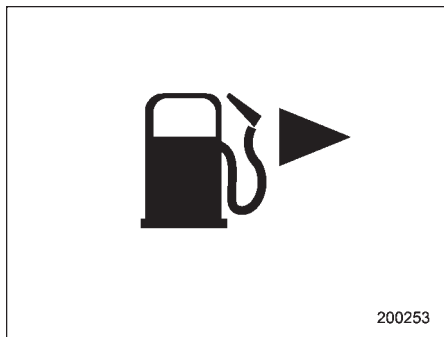

You will see the "🚰▶" sign in the fuel

gauge.

This indicates that the fuel filler door (lid) is located on the right side of the vehicle.

■ **ECO gauge**

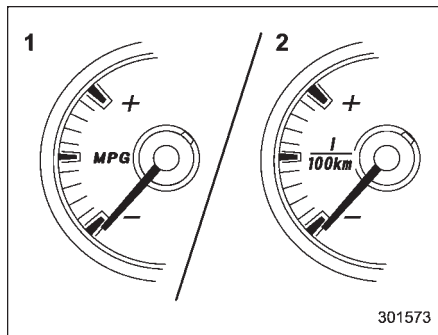

- 1) U.S. spec. models
- 2) Except U.S. spec. models

The ECO gauge shows the difference between the average rate of fuel consumption since the trip meter was last reset and the current rate of fuel consumption.

The ECO gauge indicates the current fuel efficiency as shown in the following chart.

Displayed unit	Needle position	
	"+" side	"-" side
MPG	Better	Poorer
l/100km	Poorer	Better







NOTE















- The ECO gauge shows only an approximate indication.
- After resetting the trip meter, the average rate of fuel consumption is not shown until driving 0.6 mile (1 km). Until that time, the ECO gauge does not operate.

Warning and indicator lights

Several of the warning and indicator lights illuminate momentarily and then go out when the ignition switch is initially turned to the "ON" position. This permits checking the operation of the bulbs.

Apply the parking brake and turn the ignition switch to the "ON" position. For the system check, the following lights illuminate and turn off after several seconds or after the engine has started:

- : Seatbelt warning light
(The seatbelt warning light turns off only when the driver fastens the seatbelt.)
- : Front passenger's seatbelt warning light
(The seatbelt warning light turns off only when the front seat passenger fastens the seatbelt.)
- : SRS airbag system warning light
- ON / : Front passenger's frontal airbag ON indicator light
- OFF / : Front passenger's frontal airbag OFF indicator light
- : CHECK ENGINE warning light/Malfunction indicator light

- : Coolant temperature high warning light
- : Charge warning light
- : Oil pressure warning light
- : Engine low oil level warning light
- : Windshield washer fluid warning light
- : AT OIL TEMP warning light
(AT and CVT models)
- ABS / : ABS warning light
- : Vehicle Dynamics Control warning light/Vehicle Dynamics Control operation indicator light
- : Vehicle Dynamics Control OFF indicator light
- BRAKE / : Brake system warning light
- : Hill Holder indicator light
- AWD: All-Wheel Drive warning light (AT and CVT models)
- : Low tire pressure warning light
(U.S. spec. models)
- : Low fuel warning light
- : Door open indicator light
- CRUISE: Cruise control indicator light
- : Cruise control set indicator light

- : Select lever/gear position indicator

If any lights fail to illuminate, it indicates a burned-out bulb or a malfunction of the corresponding system.

Consult your authorized SUBARU dealer for repair.

■ Seatbelt warning light and chime



Your vehicle is equipped with a seatbelt warning device at the driver's and front passenger's seat, as required by current safety standards.

With the ignition switch turned to the "ON" position, this device reminds the driver and front passenger to fasten their seatbelts by the warning lights in the locations indicated in the following illustration and a chime.

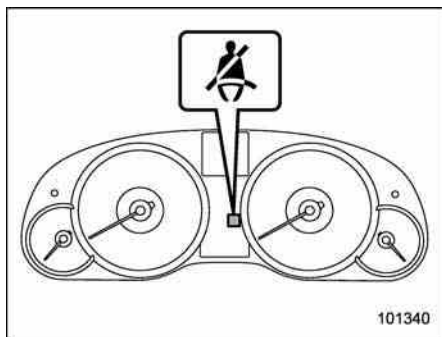

Driver's warning light

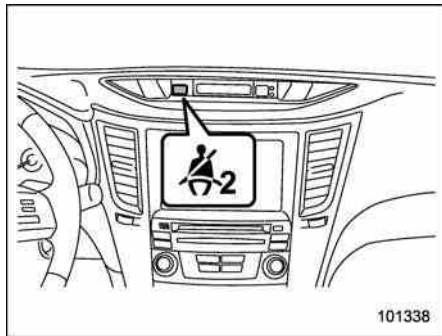

Front passenger's warning light

▼ Operation

If the driver and/or front passenger have/has not yet fastened the seatbelt(s) when

the ignition switch is turned to the "ON" position, the seatbelt warning light(s) will flash for 6 seconds, to warn that the seatbelt(s) is/are unfastened. If the driver's seatbelt is not fastened, a chime will also sound simultaneously.

NOTE

- If the driver's and/or front passenger's seatbelt(s) are/is still not fastened 6 seconds later, the seatbelt warning device operates as follows according to the vehicle speed.

- At speeds lower than approximately 9 mph (15 km/h)

The warning light(s) for unfastened seatbelt(s) will alternate between steady illumination and flashing at 15-second intervals. The chime will not sound.

- At speeds higher than approximately 9 mph (15 km/h)

The warning light(s) for unfastened seatbelt(s) will alternate between flashing and steady illumination at 15-second intervals and the chime will sound while the warning light(s) is/are flashing.

- It is possible to cancel the warning operation that follows the 6-second warning after turning ON the ignition switch. When the ignition switch is

turned ON next time, however, the complete sequence of the warning operation resumes. For further details about canceling the warning operation, please contact your SUBARU dealer.

If there is no passenger on the front passenger's seat, the seatbelt warning device for the front passenger's seat will be deactivated. The front passenger's occupant detection system monitors whether or not there is a passenger on the front passenger's seat.

Observe the following precautions. Failure to do so may prevent the device from functioning correctly or cause the device to fail.

- Do not install any accessory such as a table or TV onto the seatback.
- Do not store a heavy load in the seatback pocket.
- Do not allow the rear seat occupant to place his/her hands or legs on the front passenger's seatback, or allow him/her to pull the seatback.
- Do not use front seats with their backward-forward position and seatback not being locked into place securely. If any of them are not locked securely, adjust them again. For adjusting procedure, refer to "Manual seat" 1-3 (models equipped with manual seats only).

If the seatbelt warning device for the front passenger's seat does not function correctly (e.g., it is activated even when the front passenger's seat is empty or it is deactivated even when the front passenger has not fastened his/her seatbelt), take the following actions.

- Ensure that no article is placed on the seat other than a child restraint system and its child occupant.
- Ensure that there is no article left in the seatback pocket.
- Ensure that the backward-forward position and seatback of front passenger's seat are locked into place securely by moving the seat back and forth. (Models equipped with manual seats only)

If still the seatbelt warning device for front passenger's seat does not function correctly after taking relevant corrective actions described above, immediately contact your SUBARU dealer for an inspection.

■ SRS airbag system warning light



▲ WARNING

If the warning light exhibits any of the following conditions, there may be a malfunction in the seatbelt

pretensioners and/or SRS airbag system. Immediately take your vehicle to your nearest SUBARU dealer to have the system checked. Unless checked and properly repaired, the seatbelt pretensioners and/or SRS airbags will operate improperly (e.g. SRS airbags may inflate in a very minor collision or not inflate in a severe collision), which may increase the risk of injury.

- Flashing or flickering of the warning light
- No illumination of the warning light when the ignition switch is first turned to the "ON" position
- Continuous illumination of the warning light
- Illumination of the warning light while driving

■ Front passenger's frontal airbag ON and OFF indicators

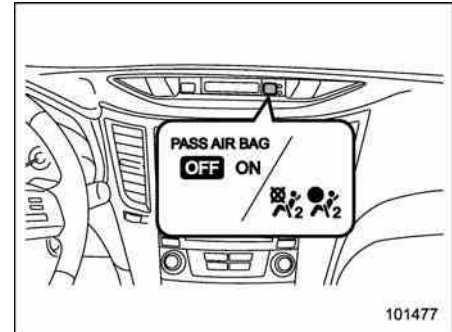

ON or : Front passenger's frontal airbag ON indicator

OFF or : Front passenger's frontal airbag OFF indicator

The front passenger's frontal airbag ON and OFF indicators show you the status of the front passenger's SRS frontal airbag. The indicators are located next to the clock in the center portion of the dashboard.

When the ignition switch is turned to the "ON" position, both the ON and OFF indicators illuminate for 6 seconds during which time the system is checked. Following the system check, both indicators turn off for 2 seconds. After that, one of the

indicators illuminates depending on the status of the front passenger's SRS frontal airbag determined by the SUBARU advanced frontal airbag system monitoring. If the front passenger's SRS frontal airbag is activated, the passenger's frontal airbag ON indicator will illuminate while the OFF indicator will remain off.

If the front passenger's SRS frontal airbag is deactivated, the passenger's frontal airbag ON indicator will remain off while the OFF indicator will illuminate.

With the ignition switch turned to the "ON" position, if both the ON and OFF indicators remain illuminated or off simultaneously even after the system check period, the system is malfunctioning. Contact your SUBARU dealer immediately for an inspection.

■ CHECK ENGINE warning light/Malfunction indicator light

CHECK
ENGINE



CAUTION

If the CHECK ENGINE warning light/malfunction indicator light illuminates while you are driving, have your vehicle checked/repared by your SUBARU dealer as soon as possible. Continued vehicle opera-

tion without having the emission control system checked and repaired as necessary could cause serious damage, which may not be covered by your vehicle's warranty.

If this light illuminates steadily or blinks while the engine is running, it may indicate that there is a problem or potential problem somewhere in the emission control system.

▼ If the light illuminates constantly

If the light illuminates constantly while driving or does not turn off after the engine starts, an emission control system malfunction has been detected.

You should have your vehicle checked by an authorized SUBARU dealer immediately.

NOTE

This light also illuminates when the fuel filler cap is not tightened until it clicks.

If you have recently refueled your vehicle, the cause of the CHECK ENGINE warning light/malfunction indicator light coming on could be a loose or missing fuel filler cap. Remove the cap and retighten it until it clicks. Make sure nothing is interfering with the sealing of the cap. Tightening the cap will not make the CHECK ENGINE

warning light/malfunction indicator light turn off immediately. It may take several driving trips. If the light does not turn off, take your vehicle to your authorized SUBARU dealer immediately.

▼ If the light is blinking

If the light is blinking while driving, an engine misfire condition has been detected which may damage the emission control system.

To prevent serious damage to the emission control system, you should conform to the following instructions.

- Reduce vehicle speed.
- Avoid hard acceleration.
- Avoid steep uphill grades.
- Reduce the amount of cargo, if possible.
- Stop towing a trailer as soon as possible.

The CHECK ENGINE warning light/malfunction indicator light may stop blinking and illuminate steadily after several driving trips. You should have your vehicle checked by an authorized SUBARU dealer immediately.

■ Coolant temperature low indicator light/Coolant temperature high warning light



CAUTION

- After turning the ignition switch to the “ON” position, if this indicator light/warning light behaves under any of the following conditions, the electrical system may be malfunctioning. Contact your SUBARU dealer immediately for an inspection.
 - It remains blinking in RED.
 - It remains illuminated in RED for more than 2 seconds.
 - It remains blinking in RED and BLUE alternately.
- While driving, if this indicator light/warning light behaves under any of the following conditions, take the specified appropriate measure listed below.
 - **Blinking in RED:**
Decelerate the vehicle. After the blinking RED light turns off, you can drive the vehicle normally.
 - **Illuminated in RED:**

Safely stop the vehicle as soon as possible, and refer to the emergency steps for the case of engine overheating. After that, have the system checked by your nearest SUBARU dealer. Refer to “Engine overheating” 9-13.

- **Blinking in RED and BLUE alternately:**
The electrical system may be malfunctioning. Contact your SUBARU dealer for an inspection.

This coolant temperature low indicator light/coolant temperature high warning light has the following three functions.

- Illumination in **BLUE** indicates insufficient warming up of the engine
- Blinking in **RED** indicates that the engine is close to overheating
- Illumination in **RED** indicates overheating condition of the engine

For the system check, this indicator light/warning light illuminates in **RED** for approximately 2 seconds when the ignition switch is turned to the “ON” position. After that, this indicator light/warning light changes to **BLUE** and maintains illumination in **BLUE**. This **BLUE** illuminated light

turns off when the engine is warmed up sufficiently.

If the engine coolant temperature increases over the specified range, the indicator light/warning light blinks in **RED**. At this time, decelerate the vehicle. After the blinking **RED** light turns off, you can drive the vehicle normally. However, if the indicator light/warning light often blinks in **RED**, the electrical system may be malfunctioning. Contact your SUBARU dealer for an inspection.

If the engine coolant temperature increases further, the indicator light/warning light illuminates in **RED** continuously. At this time, the engine may be overheating. Safely stop the vehicle as soon as possible, and refer to the emergency steps for the case of engine overheating. Refer to “Engine overheating” 9-13. After that, have the system checked by your nearest SUBARU dealer.

NOTE

If the engine is restarted after a certain driving condition, this indicator light/warning light may illuminate in **RED**. However, this is not a malfunction if the indicator light/warning light turns off after a short time.

■ Charge warning light



If this light illuminates when the engine is running, it may indicate that the charging system is not working properly.

If the light illuminates while driving or does not turn off after the engine starts, stop the engine at the first safe opportunity and check the alternator belt. If the belt is loose, broken or if the belt is in good condition but the light remains illuminated, contact your nearest SUBARU dealer immediately.

■ Oil pressure warning light



CAUTION

Do not operate the engine with the oil pressure warning light on. This may cause serious engine damage.

If this light illuminates when the engine is running, it may indicate that the engine oil pressure is low and the lubricating system is not working properly.

If the light illuminates while driving or does not turn off after the engine starts, stop the engine at the first safe opportunity and check the engine oil level. If the oil level is low, add oil immediately. If the engine oil is

at the proper level but the light remains illuminated, contact your nearest SUBARU dealer immediately.

■ Engine low oil level warning light



This light illuminates when the engine oil level decreases to the lower limit. The illuminating conditions and remaining oil level are shown in the following items.

2.5 L models:

- when the ignition switch is in the “ON” position but the engine is not running: approximately 1.9 US qt (1.8 liters, 1.6 Imp qt)
- while the engine is running: approximately 3.2 US qt (3.0 liters, 2.6 Imp qt)

3.6 L models:

- when the ignition switch is in the “ON” position but the engine is not running: approximately 4.0 US qt (3.8 liters, 3.3 Imp qt)
- while the engine is running: approximately 5.6 US qt (5.3 liters, 4.7 Imp qt)

If the engine low oil level warning light illuminates while driving, park the vehicle at a safe and level location, and then check the engine oil level. When the engine oil level is not within the normal range, refill with engine oil if necessary.

Refer to “Engine oil” 11-12.

If the warning light does not turn off after refilling with engine oil or the warning light illuminates even though the engine oil level is within the normal range, have the system checked by a SUBARU dealer.

NOTE

- **The engine low oil level warning light will not turn off immediately even if you replace or add engine oil. It will turn off only when the vehicle is idling and the engine is warmed up completely.**
- **When the vehicle is considerably inclined on an uphill or steep slope, the warning light may illuminate temporarily due to the movement of engine oil in the engine.**

■ AT OIL TEMP warning light (AT and CVT models)

AT OIL
TEMP

If this light illuminates when the engine is running, it may indicate that the transmission fluid temperature is too hot.

If the light illuminates while driving, immediately stop the vehicle in a safe place and let the engine idle until the warning light turns off.

▼ Transmission control system warning

If the "AT OIL TEMP" warning light flashes after the engine has started, it may indicate that the transmission control system is not working properly. Contact your nearest SUBARU dealer for service immediately.

■ Low tire pressure warning light (U.S. spec. models)

When the ignition switch is turned to the "ON" position, the low tire pressure warning light will illuminate for approximately 2 seconds to check that the tire pressure monitoring system (TPMS) is functioning properly. If there is no problem and all tires are properly inflated, the light will go out.

Each tire, including the spare (if provided), should be checked monthly when cold and inflated to the inflation pressure recommended by the vehicle manufacturer on the vehicle placard or tire inflation pressure label. (If your vehicle has tires of a different size than the size indicated on the vehicle placard or tire inflation pressure label, you should determine the proper tire inflation pressure for those tires.)

As an added safety feature, your vehicle

has been equipped with a tire pressure monitoring system (TPMS) that illuminates a low tire pressure telltale when one or more of your tires is significantly under-inflated. Accordingly, when the low tire pressure telltale illuminates, you should stop and check your tires as soon as possible, and inflate them to the proper pressure. Driving on a significantly under-inflated tire causes the tire to overheat and can lead to tire failure. Under-inflation also reduces fuel efficiency and tire tread life, and may affect the vehicle's handling and stopping ability.

Please note that the TPMS is not a substitute for proper tire maintenance, and it is the driver's responsibility to maintain correct tire pressure, even if under-inflation has not reached the level to trigger illumination of the TPMS low tire pressure telltale.

Your vehicle has also been equipped with a TPMS malfunction indicator to indicate when the system is not operating properly. The TPMS malfunction indicator is combined with the low tire pressure telltale. When the system detects a malfunction, the telltale will flash for approximately one minute and then remain continuously illuminated. This sequence will continue upon subsequent vehicle start-ups as long as the malfunction exists. When the

malfunction indicator is illuminated, the system may not be able to detect or signal low tire pressure as intended. TPMS malfunctions may occur for a variety of reasons, including the installation of replacement or alternate tires or wheels on the vehicle that prevent the TPMS from functioning properly. Always check the TPMS malfunction telltale after replacing one or more tires or wheels on your vehicle to ensure that the replacement or alternate tires and wheels allow the TPMS to continue to function properly.

Should the warning light illuminate steadily after blinking for approximately one minute, have the system inspected by your nearest SUBARU dealer as soon as possible.



WARNING

If this light does not illuminate briefly after the ignition switch is turned ON or the light illuminates steadily after blinking for approximately one minute, you should have your Tire Pressure Monitoring System checked at a SUBARU dealer as soon as possible.

If this light illuminates while driving, never brake suddenly and keep driving straight ahead while gradu-

ally reducing speed. Then slowly pull off the road to a safe place. Otherwise an accident involving serious vehicle damage and serious personal injury could occur.

If this light still illuminates while driving after adjusting the tire pressure, a tire may have significant damage and a fast leak that causes the tire to lose air rapidly. If you have a flat tire, replace it with a spare tire as soon as possible.

When a spare tire is mounted or a wheel rim is replaced without the original pressure sensor/transmitter being transferred, the Low tire pressure warning light will illuminate steadily after blinking for approximately one minute. This indicates the TPMS is unable to monitor all four road wheels. Contact your SUBARU dealer as soon as possible for tire and sensor replacement and/or system resetting. If the light illuminates steadily after blinking for approximately one minute, promptly contact a SUBARU dealer to have the system inspected.



CAUTION

The tire pressure monitoring system is NOT a substitute for manually checking tire pressure. The tire pressure should be checked periodically (at least monthly) using a tire gauge. After any change to tire pressure(s), the tire pressure monitoring system will not re-check tire inflation pressures until the vehicle is first driven more than 20 mph (32 km/h). After adjusting the tire pressures, increase the vehicle speed to at least 20 mph (32 km/h) to start the TPMS re-checking of the tire inflation pressures. If the tire pressures are now above the severe low pressure threshold, the low tire pressure warning light should turn off a few minutes later. Therefore, be sure to install the specified size for the front and rear tires.

■ ABS warning light



CAUTION

- If any of the following conditions occur, we recommend that you have the ABS system repaired at the first available opportunity by

your SUBARU dealer.

- The warning light does not illuminate when the ignition switch is turned to the “ON” position.
- The warning light illuminates when the ignition switch is turned to the “ON” position, but it does not turn off even when the vehicle speed exceeds approximately 12 km/h (8 mph).
- The warning light illuminates during driving.
- The warning light flashes.
- When the warning light is on (and brake system warning light is off), the ABS function shuts down; however, the conventional brake system continues to operate normally.
- When the warning light is flashing, the ABS system may be malfunctioning. However, the conventional brake system continues to operate normally.

The ABS warning light illuminates together with the brake system warning light if the EBD system malfunctions. For further details of the EBD system mal-

function warning, refer to “Brake system warning light” 3-17.

NOTE

If the warning light behavior is as described in the following conditions, the ABS system may be considered normal.

- The warning light illuminates right after the engine is started but turns off immediately, remaining off.
- The warning light remains illuminated after the engine has been started, but it turns off when the vehicle speed reaches approximately 8 mph (12 km/h).
- The warning light illuminates during driving, but it turns off immediately and remains off.

When driving with an insufficient battery voltage such as when the engine is jump started, the ABS warning light may illuminate. This is due to the low battery voltage and does not indicate a malfunction. When the battery becomes fully charged, the light will turn off.

■ Brake system warning light

BRAKE / (!)

WARNING

- Driving with the brake system warning light on is dangerous. This indicates your brake system may not be working properly. If the light remains illuminated, have the brakes inspected by a SUBARU dealer immediately.
- If at all in doubt about whether the brakes are operating properly, do not drive the vehicle. Have your vehicle towed to the nearest SUBARU dealer for repair.
- If the brake system warning light flashes, the electronic parking brake system may be malfunctioning. Immediately stop your vehicle in a safe location, use tire stops under the tires to prevent the vehicle from moving and contact your SUBARU dealer. For details, refer to “Electronic parking brake” 7-31.

NOTE

- When the ignition switch is turned to the “LOCK” position with the electronic parking brake applied, the brake system warning light remains illuminated for approximately 30 seconds and then turns off.
- When the electronic parking brake switch is pressed to apply the electronic parking brake while the ignition switch is in the “LOCK” position, the brake system warning light illuminates, remains illuminated for approximately 30 seconds and then turns off.
- Even if the brake system warning light flashes, if the warning light behavior is as described in the following examples, the electronic parking brake system is not malfunctioning.
 - The warning light turns off when the electronic parking brake is applied or released.
 - The warning light turns off when the ignition switch is turned to the “ON” position again.
- The brake system warning light may flash immediately after the engine is started. However, it is not malfunctioning if the warning light turns off after the electronic parking brake is released.
- The brake system warning light may

flash after the electronic parking brake is frequently applied and released. However, the electronic parking brake system is not malfunctioning if the light turns off for a short period of time.

This light has the following functions:

▼ **Parking brake warning**

The light illuminates with the parking brake applied while the ignition switch is in the "ON" position. It turns off when the parking brake is released.

▼ **Brake fluid level warning**

This light illuminates when the brake fluid level has dropped to near the "MIN" level of the brake fluid reservoir with the ignition switch in the "ON" position and with the parking brake released.

If the brake system warning light should illuminate while driving (with the parking brake released and with the ignition switch positioned in "ON"), it could be an indication of leaking of brake fluid or worn brake pads. If this occurs, immediately stop the vehicle at the nearest safe place and check the brake fluid level. If the fluid level is below the "MIN" mark in the reservoir, do not drive the vehicle. Have the vehicle towed to the nearest SUBARU dealer for repair.

▼ **Electronic Brake Force Distribution (EBD) system warning**

The brake system warning light also illuminates if a malfunction occurs in the EBD system. In that event, it illuminates together with the ABS warning light.

The EBD system may be malfunctioning if the brake system warning light and ABS warning light illuminate simultaneously during driving.

Even if the EBD system fails, the conventional braking system will still function. However, the rear wheels will be more prone to locking when the brakes are applied harder than usual and the vehicle's motion may therefore become somewhat harder to control.

If the brake system warning light and ABS warning light illuminate simultaneously, take the following steps:

1. Stop the vehicle in the nearest safe, flat place.
2. Shut down the engine, then restart it.
3. Release the parking brake. If both warning lights turn off, the EBD system may be malfunctioning.

Drive carefully to the nearest SUBARU dealer and have the system inspected.

4. If both warning lights illuminate again and remain illuminated after the engine has been restarted, shut down the engine

again, apply the parking brake, and check the brake fluid level. Refer to "Brake fluid"  11-25.

5. If the brake fluid level is not below the "MIN" mark, the EBD system may be malfunctioning. Drive carefully to the nearest SUBARU dealer and have the system inspected.

6. If the brake fluid level is below the "MIN" mark, DO NOT drive the vehicle. Instead, have the vehicle towed to the nearest SUBARU dealer for repair.

▼ **Electronic parking brake system warning**

The brake system warning light flashes when the electronic parking brake system is malfunctioning. If the warning light flashes, promptly park in a safe location as soon as possible and contact your SUBARU dealer.

The brake system warning light remains illuminated when the parking brake cannot be released even if the parking brake switch is pulled. For details, refer to "Electronic parking brake"  7-31.

▽ **Parking brake apply inhibit warning**

The brake system warning light flashes for 10 seconds and a chirp sound will be heard if the parking brake switch is operated when the parking brake cannot

be applied.

▽ Frequent operation warning

The brake system warning light flashes for 20 seconds and a chirp sound will be heard if the parking brake switch is operated too frequently. In this case, the operation of the parking brake switch is restricted to protect the electronic parking brake system.

NOTE

Wait until the warning light turns off.

▽ Emergency released warning

The brake system warning light flashes when the parking brake is automatically released in case of an emergency.

■ Hill Holder indicator light



WARNING

If the Hill Holder indicator light does not illuminate even when the Hill Holder switch is pressed to activate the Hill Holder function, the electronic parking brake system may be malfunctioning. Immediately stop the vehicle in a safe location and contact your SUBARU dealer.

The light illuminates when the Hill Holder switch is pressed to activate the Hill Holder function. For details about the Hill Holder function, "Hill Holder function" 7-32.

■ Low fuel warning light



The low fuel warning light illuminates when the tank is nearly empty approximately 2.6 US gal (10.0 liters, or 2.2 Imp gal). It only operates when the ignition switch is in the "ON" position.

NOTE

This light does not turn off unless the tank is replenished up to an internal fuel quantity of approximately 3.7 US gal (14 liters, 3.1 Imp gal).



CAUTION

Promptly put fuel in the tank whenever the low fuel warning light illuminates. Engine misfires as a result of an empty tank could cause damage to the engine.

■ Door open indicator light



When any of the doors, the rear gate (Outback) or the trunk lid (Legacy) is not fully closed, the door open indicator light illuminates. This function is effective even if the ignition switch is in the "LOCK" or "Acc" position or the key is removed from the ignition switch.

The open door is indicated by the corresponding part of the door open warning light.

Always make sure this light is not illuminated before you start to drive.

■ Windshield washer fluid warning light



This light illuminates when the fluid level in the windshield washer fluid tank decreases to the lower limit (approximately 0.6 US qt, 0.6 liter, 0.5 Imp qt).

■ All-Wheel Drive warning light (AT and CVT models) **AWD**

 **WARNING**

Continued driving with the AWD warning light flashing can lead to powertrain damage. If the AWD warning light flashes, promptly park in a safe place then check whether all four tires are the same diameter and whether any of the tires has a puncture or has lost air pressure for some other reason.

NOTE

If the temporary spare tire is used, the AWD warning light may flash. Use of the temporary spare tire should therefore be restricted to the minimum time necessary. Replace the temporary spare tire with a conventional tire as soon as possible.

This light flashes if the vehicle is driven with tires of different diameters fitted on its wheels or with the air pressure excessively low in any of its tires.

■ Vehicle Dynamics Control warning light/
Vehicle Dynamics Control operation indicator light 

▼ Vehicle Dynamics Control warning light

 **CAUTION**

The Vehicle Dynamics Control system provides its ABS control through the electrical circuit of the ABS system. Accordingly, if the ABS is inoperative, the Vehicle Dynamics Control system becomes unable to provide ABS control. As a result, the Vehicle Dynamics Control system becomes inoperative, causing the warning light to illuminate. Although both the Vehicle Dynamics Control and ABS systems are inoperative in this case, the ordinary functions of the brake system are still available. You will be safe while driving in this condition, but drive carefully and have your vehicle checked at a SUBARU dealer as soon as possible.

NOTE

- If the electrical circuit of the Vehicle Dynamics Control system itself malfunctions, the warning light only illuminates. At this time, the ABS (Anti-lock Brake System) remains fully operational.
- The warning light illuminates when the electronic control system of the ABS/Vehicle Dynamics Control system malfunctions.

The Vehicle Dynamics Control system is probably inoperative under any of the following conditions. Have your vehicle checked at a SUBARU dealer immediately.

- The warning light does not illuminate when the ignition switch is turned to the "ON" position.
- The warning light illuminates while the vehicle is running.

NOTE

If the warning light behavior is as described in the following examples, the Vehicle Dynamics Control system may be considered normal.

- The warning light illuminates right after the engine is started but turns off immediately and remains off.
- The warning light illuminates after the engine has started and turns off

while the vehicle is subsequently being driven.

- The warning light illuminates during driving, but turns off immediately and remains off.

▼ Vehicle Dynamics Control operation indicator light

The indicator light flashes during activation of the skid suppression function and during activation of the traction control function.

NOTE

- **The light may remain illuminated for a short period of time after the engine has been started, especially in cold weather. This does not indicate the existence of a problem. The light should turn off as soon as the engine has warmed up.**
- **The indicator light illuminates when the engine has developed a problem and the CHECK ENGINE warning light/malfunction indicator light is on.**

The Vehicle Dynamics Control system is probably malfunctioning under the following condition. Have your vehicle checked at a SUBARU dealer as soon as possible.

- The light does not turn off even after the lapse of several minutes (the engine has warmed up) after the engine has

started.

■ Vehicle Dynamics Control OFF indicator light



The light illuminates when the Vehicle Dynamics Control OFF switch is pressed to deactivate the Vehicle Dynamics Control system.

The Vehicle Dynamics Control system is probably malfunctioning under any of the following conditions. Have your vehicle checked at a SUBARU dealer immediately.

- The light does not illuminate when the ignition switch is turned to the "ON" position.
- The light does not turn off even after a period of approximately 2 seconds after the ignition switch has been turned to the "ON" position.

■ Security indicator light

This indicator light shows the status of the alarm system. It also indicates operation of the immobilizer system.

▼ Alarm system

It blinks to show the driver the operational status of the alarm system. For detailed information, refer to "Alarm system" 2-

15.

▼ Immobilizer system

This light blinks approximately 60 seconds after the ignition switch is turned from "ON" position to the "Acc" or "LOCK" position or immediately after the key is pulled out. Refer to "Immobilizer" 2-3.

If the indicator light does not flash, it may indicate that immobilizer system may be malfunctioning. Contact your nearest SUBARU dealer immediately.

In the event that an unauthorized key (for example, an unauthorized duplicate) is used, the security indicator light illuminates.

NOTE

Even if the security indicator light flashes irregularly or its fuse blows (the light does not flash if its fuse is blown), the immobilizer system will function normally.

■ Select lever/gear position indicator

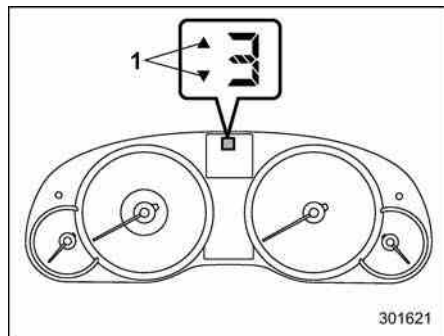

1) Upshift/downshift indicator (AT and CVT models)

This indicator shows the position of the shift lever (MT models) or select lever (AT and CVT models).

▼ Upshift/downshift indicator (AT and CVT models)

When the manual mode is selected, the gear position indicator (which shows the current gear selection) and the upshift/downshift indicator light up. Refer to "Selection of manual mode" 7-21.

▼ Gear position indicator setting (MT models)

The gear position indicator light can be activated or deactivated by performing the following procedure.

1. Turn the ignition switch to the "LOCK" position.
2. Press the trip knob to show "2 ON" or "2 OF" on the trip meter display.

The display can be switched as shown in the following illustration by pressing the trip knob.

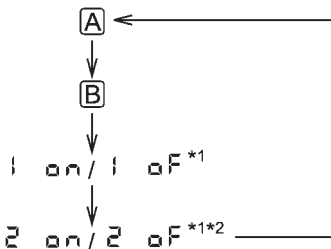

*1: "1 ON" or "1 OF" and "2 ON" or "2 OF" cannot be displayed when the ignition switch is in the "ON" position.

*2: MT models only

3. To change the current setting, press the trip knob for at least 2 seconds.

2 ON : Activated

2 OF : Deactivated

NOTE

- The initial setting for your vehicle of the gear position indicator has been set for activation "2 ON" at the time of shipment from the factory.
- It is not possible to change the setting of the gear position indicator when the ignition switch is in the "ON" position. Change the setting when the ignition switch is in the "LOCK" or "Acc" position.

■ Turn signal indicator lights ← →

These lights show the operation of the turn signal or lane change signal.

If the indicator lights do not blink or blink rapidly, the turn signal bulb may be burned out. Replace the bulb as soon as possible. Refer to "Replacing bulbs" 11-45.

■ High beam indicator light

This light shows that the headlights are in the high beam mode.

This indicator light also illuminates when the headlight flasher is operated.

■ Cruise control indicator light CRUISE

This light illuminates when the “CRUISE” main switch is pressed to activate the cruise control function.

NOTE

- If you press the main switch button while turning the ignition switch “ON”, the cruise control function is deactivated and the “CRUISE” indicator light flashes. To reactivate the cruise control function, turn the ignition switch back to the “Acc” or “LOCK” position, and then turn it again to the “ON” position.
- If this indicator light and the CHECK ENGINE warning light/malfunction indicator light flash simultaneously during driving, have the vehicle checked by your nearest SUBARU dealer.

■ Cruise control set indicator light SET

This light illuminates when vehicle speed has been set to use the cruise control function.

■ Headlight indicator light ☞☞☞

This indicator light illuminates under the following conditions.

- when the light switch is turned to the “☞☞☞” or “☞☞☞” position
- when the light switch is in the “AUTO” position and the headlights illuminate automatically

■ Front fog light indicator light (if equipped) ☞☞

This indicator light illuminates while the front fog lights are illuminated.

Clock

NOTE

Your SUBARU dealer can change the settings of activating/deactivating the automatic adjustment of the clock by the GPS (Global Positioning System) (for models with the genuine SUBARU navigation system). Contact your SUBARU dealer for details.

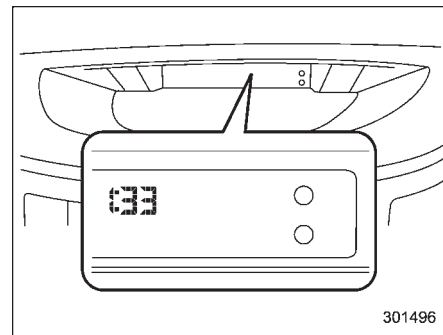

The clock shows the time while the ignition switch is in the “Acc” or “ON” position.

To adjust the time shown by the clock, press the “+” button or the “-” button. If you press the “+” button, the indicated time will change in one-minute increments. If you press the “-” button, the

indicated time will change in one-minute decrements. If you keep the button pressed, the rate at which the indicated time changes will speed up.

Multi function display

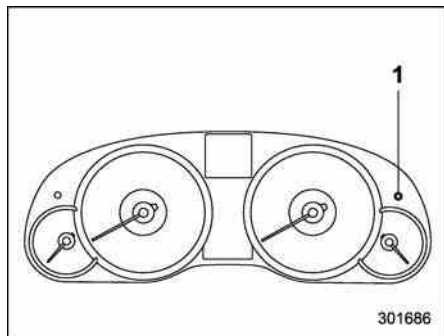
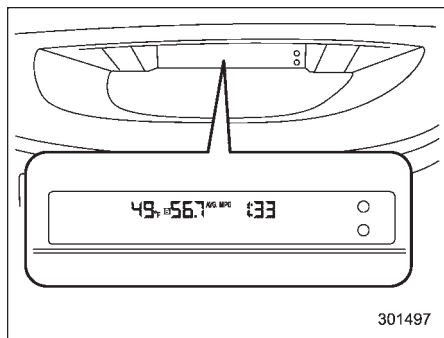

1) Multi function display switching knob

With the ignition switch in the "ON" position, each successive press of the multi function display switching knob

toggles the display in the following sequence.

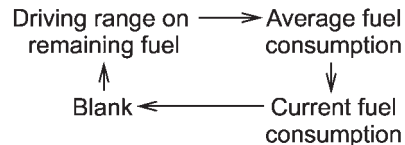

The outside temperature is always indicated on the display with the ignition switch in the "ON" position.

■ Outside temperature indicator

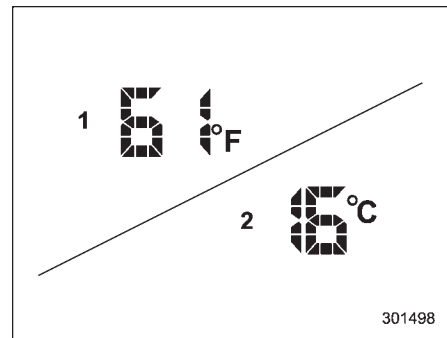

- 1) U.S. spec. models
- 2) Except U.S. spec. models

The outside temperature indicator shows the outside temperature in a range from

-22 to 122°F (-30 to 50°C).

The indicator can give a false reading under any of the following conditions:

- When there is too much sun.
- During idling; while running at low speeds in a traffic jam; when the engine is restarted immediately following a shut-down.
- When the actual outside temperature falls outside the specified indicator range.

▼ Road surface freeze warning indication

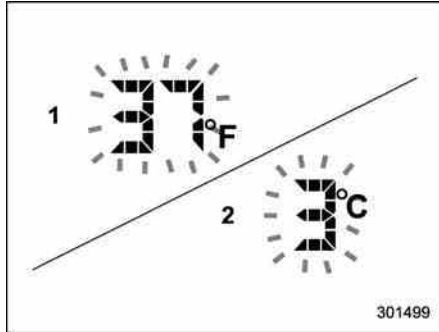

- 1) U.S. spec. models
- 2) Except U.S. spec. models

When the outside temperature drops to 37°F (3°C) or lower, the temperature indication flashes to show that the road

surface may be frozen.

If the outside temperature drops to 37°F (3°C) or lower while the display is giving an indication other than the outside temperature, the display switches to the outside temperature indication and flashes for 5 seconds before returning to its original indication.

If the display is already indicating an outside temperature of 37°F (3°C) or lower when the ignition switch is turned to the "ON" position, the indication does not flash.

NOTE

The outside temperature indication may differ from the actual outside temperature. The road surface freeze warning indication should be treated only as a guide. Be sure to check the condition of the road surface before driving.

■ Average fuel consumption

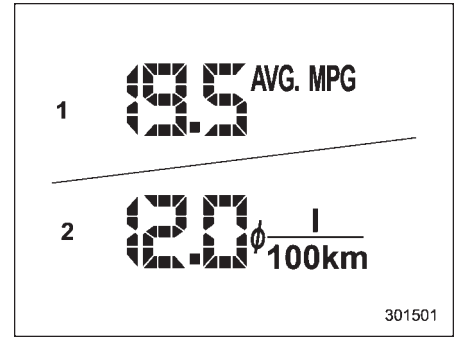

- 1) U.S. spec. models
- 2) Except U.S. spec. models

This indication shows the average rate of fuel consumption since the trip meter was last reset.

Pressing the trip knob toggles the indication between the average fuel consumption corresponding to the A trip meter indication and the average fuel consumption corresponding to the B trip meter indication.

When either of the trip meter indications is reset, the corresponding average fuel consumption value is also reset.

NOTE

• The indicated values vary in accordance with changes in the vehicle's running conditions. Also, the indicated values may differ slightly from the actual values and should thus be treated only as a guide.

• When either trip meter indication is reset, the average fuel consumption corresponding to that trip meter indication is not shown until the vehicle has subsequently covered a distance of 1 mile (or 1 km).

■ Current fuel consumption

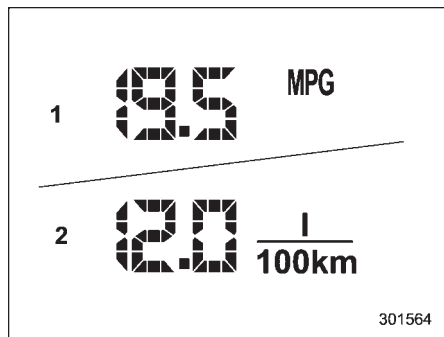

- 1) U.S. spec. models
- 2) Except U.S. spec. models

This indication shows the rate of fuel

consumption at the present moment.

■ Driving range on remaining fuel

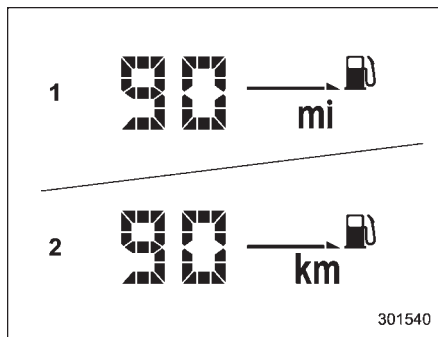

- 1) U.S. spec. models
- 2) Except U.S. spec. models

The driving range indicates the distance that can be driven taking into account the amount of fuel remaining in the tank and the average rate of fuel consumption.

When the low fuel warning light illuminates, the driving range indication flashes for 5 seconds. (The display first switches to the driving range indication if it was originally giving some other indication.)

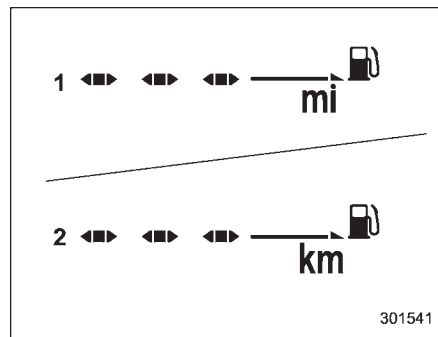

- 1) U.S. spec. models
- 2) Except U.S. spec. models

If the driving range is shown as "...", there is only a tiny amount of fuel left in the tank. You must refuel the vehicle immediately.

NOTE

The driving range on remaining fuel is only a guide. The indicated value may differ from the actual driving range on remaining fuel, so you must immediately fill the tank when the low fuel warning light illuminates.

Light control switch

The light control switch only operates when the key is inserted into the ignition switch.

Regardless of the position of the light control switch, the illuminated lights are turned off when the key is removed from the ignition switch.

NOTE

- Even if the key is removed from the ignition switch, the lights can be illuminated by operating the light control switch position from “OFF” to “

CAUTION

- Use of any lights for a long period of time while the engine is not running can cause the battery to discharge.
- Before leaving the vehicle, make sure that the light control switch is turned to the “OFF” position. If the vehicle is left unattended for

a long time with the light control switch set to a position other than “OFF”, the battery may be discharged.

Headlights

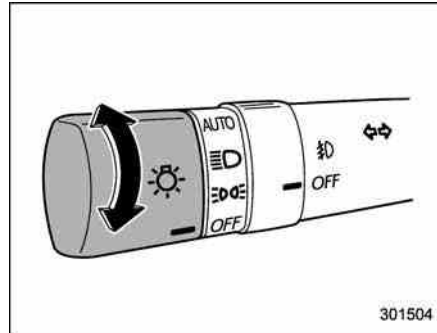

To turn on the headlights, turn the knob on the end of the turn signal lever.

first position

Instrument panel illumination, tail lights, front side marker lights and license plate lights are on.

second position

Headlights, instrument panel illumination, front side marker lights, tail lights and license plate lights are on.

AUTO: Auto on/off headlights

When the ignition switch is in the “ON” position, the headlights, instrument panel illumination, front side marker lights, tail lights and license plate lights are automatically on or off depending on the level of the ambient light.

NOTE

The sensitivity of the auto on/off headlights can be changed by your SUBARU dealer. Contact your SUBARU dealer for details.

▼ Sensor for the auto on/off headlights

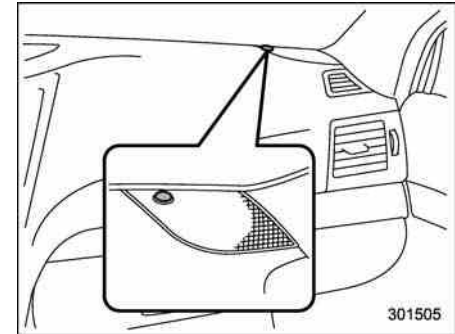

The sensor is on the instrument panel as shown in the illustration.

CAUTION

If any object is placed on or near the sensor, the sensor may not detect the level of the ambient light correctly and the auto on/off headlights may not operate properly.

High/low beam change (dimmer)

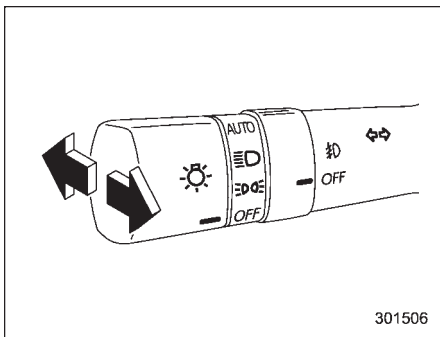

To change from low beam to high beam, push the turn signal lever forward. When the headlights are on high beam, the high beam indicator light “

To switch back to low beam, pull the lever back to the detent position.

Headlight flasher

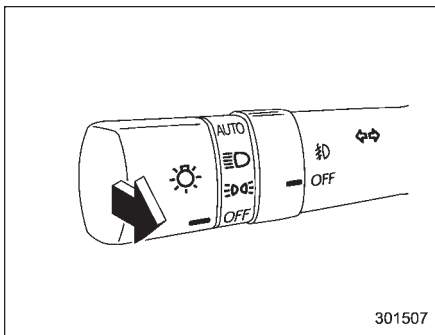

CAUTION

Do not hold the lever in the flashing position for more than just a few seconds.

To flash the headlights, pull the lever toward you and then release it. The high beam will stay on for as long as you hold the lever. The headlight flasher works even though the lighting switch is in the “OFF” position.

When the headlights are on high beam, the high beam indicator light “

Daytime running light system

WARNING

The brightness of the illumination of the high beam headlights is reduced by the daytime running light system. The light switch must always be turned to the “

The high beam headlights will automatically illuminate at reduced brightness when the engine has started, under the following conditions.

- The parking brake is fully released.
- The light switch is in the “OFF” or “

NOTE

When the light switch is in the “

Turn signal lever

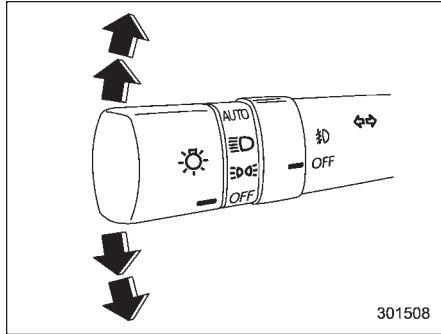

To activate the right turn signal, push the turn signal lever up. To activate the left turn signal, push the turn signal lever down. When the turn is finished, the lever will return automatically. If the lever does not return after cornering, return the lever to the neutral position by hand.

To signal a lane change, push the turn signal lever up or down slightly and hold it during the lane change. The turn signal indicator lights will flash in the direction of the turn or lane change. The lever will return automatically to the neutral position when you release it.

Illumination brightness control

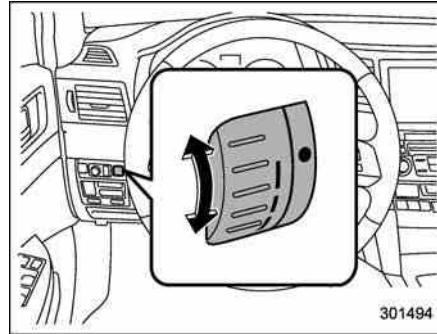

The illumination brightness of the clock display, audio, air conditioner, multi function display and meter/gauge dims under the following conditions.

- when the light switch is in the “ ☀ ” or “ ☀ ” position
- when the light switch is in the “AUTO” position and the headlights illuminate automatically

You can adjust the illumination brightness for better visibility.

To brighten, turn the control dial upward.
To darken, turn the control dial downward.

NOTE

- When the control dial is turned fully upward, the illumination brightness becomes the maximum and the automatic dimming function does not work at all.
- The brightness setting is not canceled even when the ignition switch is turned to the “LOCK” position.

Front fog light switch (if equipped)

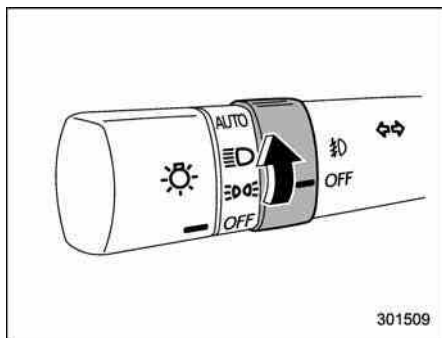

The front fog lights operate under the following conditions.

- when the light switch is in the “” position
- when the light switch is in the “AUTO” position and the headlights turn on automatically

However, the front fog lights turn off when the headlights are switched to high beam.

To turn on the front fog lights, turn the front fog light switch on the turn signal lever upward to the “” position. To turn off the front fog lights, turn the switch back down to the “OFF” position.

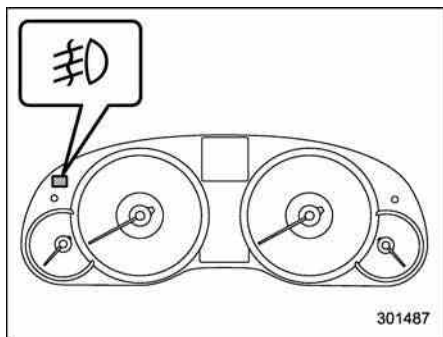

The indicator light located on the combination meter will illuminate when the front fog lights are on.

Wiper and washer

WARNING

In freezing weather, do not use the windshield washer until the windshield is sufficiently warmed by the defroster.

Otherwise the washer fluid can freeze on the windshield, blocking your view.

CAUTION

- Do not operate the washer continuously for more than 10 seconds, or when the washer fluid tank is empty. This may cause overheating of the washer motor. Check the washer fluid level frequently, such as at fuel stops.
- Do not operate the wipers when the windshield or rear window is dry. This may scratch the glass, damage the wiper blades and cause the wiper motor to burn out. Before operating the wiper on a dry windshield or rear window, always use the windshield washer.

- In freezing weather, be sure that the wiper blades are not frozen to the windshield or rear window before switching on the wipers. Attempting to operate the wiper with the blades frozen to the window glass could cause not only the wiper blades to be damaged but also the wiper motor to burn out. If the wiper blades are frozen to the window glass, be sure to operate the defroster, wiper deicer (if equipped) or rear window defogger before turning on the wiper.
- If the wipers stop during operation because of ice or some other obstruction on the window, the wiper motor could burn out even if the wiper switch is turned off. If this occurs, promptly stop the vehicle in a safe place, turn the ignition switch to the "LOCK" position and clean the window glass to allow proper wiper operation.
- Use clean water if windshield washer fluid is unavailable. In areas where water freezes in winter, use SUBARU Windshield Washer Fluid or the equivalent. Refer to "Windshield washer

fluid" 11-37.

Also, when driving the vehicle when there are freezing temperatures, use non-freezing type wiper blades.

- Do not clean the wiper blades with gasoline or a solvent, such as paint thinner or benzene. This will cause deterioration of the wiper blades.

NOTE

- The front wiper motor is protected against overloads by a circuit breaker. If the motor operates continuously under an unusually heavy load, the circuit breaker may trip to stop the motor temporarily. If this happens, park your vehicle in a safe place, turn off the wiper switch, and wait for approximately 10 minutes. The circuit breaker will reset itself, and the wipers will again operate normally.
- Clean your wiper blades and window glass periodically with a washer solution to prevent streaking, and to remove accumulations of road salt or road film. Keep the washer button depressed at least for 1 second so that washer solution will be sprinkled all over the windshield or rear window.

- Grease, wax, insects or other material on the windshield or the wiper blades results in jerky wiper operation and streaking on the glass. If you cannot remove those streaks after operating the washer or if the wiper operation is jerky, clean the outer surface of the windshield or rear window and the wiper blades using a sponge or soft cloth with a neutral detergent or mild abrasive cleaner. After cleaning, rinse the window glass and wiper blades with clean water. The glass is clean if no beads form on the glass when you rinse with water.
- If you cannot eliminate the streaking even after following this procedure, replace the wiper blades with new ones. For replacement instructions, refer to "Replacement of wiper blades" 11-39.

Windshield wiper and washer switches

The wiper operates only when the ignition switch is in the "ON" position.

Windshield wipers

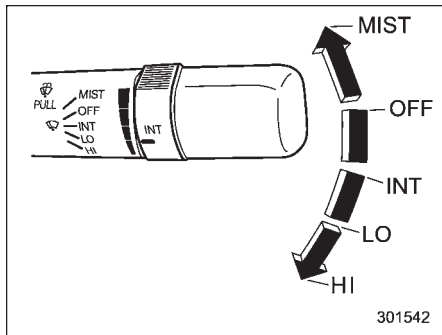

MIST : Mist (for a single wipe)

OFF : Off

INT: Intermittent

LO: Low speed

HI: High speed

To turn the wipers on, push the wiper control lever down.

To turn the wipers off, return the lever to the "OFF" position.

For a single wipe of the wipers, push the lever up. The wipers operate until you release the lever.

Wiper intermittent time control

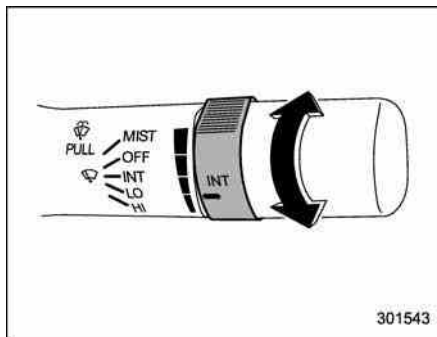

When the wiper switch is in the "INT" position, turn the dial to adjust the operating interval of the wiper. The operating interval can be adjusted in five steps from the shortest interval to the longest.

Windshield washer

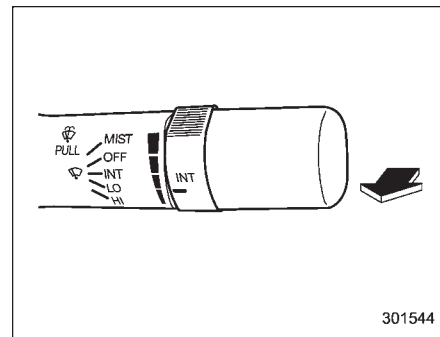

To wash the windshield, pull the wiper control lever toward you. The washer fluid sprays until you release the lever. The wipers operate while you pull the lever.

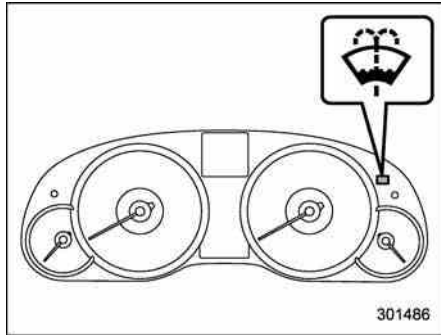
NOTE

The windshield washer fluid warning light illuminates when the washer fluid level in the tank has dropped to the lower limit. If the warning light illuminates, refill the tank with fluid. For the tank refilling method, refer to “Windshield washer fluid” 11-37.

■ Rear window wiper and washer switch (Outback)

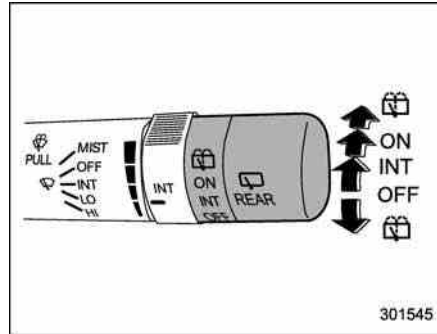

- Washer (accompanied by wiper operation)
- ON: Continuous
- INT: Intermittent
- OFF: Off
- Washer (accompanied by wiper operation)

▼ Rear wiper

To turn the rear wiper on, turn the knob on the end of the wiper control lever upward to the “INT” or “ON” position.

To turn the wiper off, return the knob on the end of the lever to the “OFF” position. With the switch turned to the “INT” position, the rear wiper will operate intermittently at intervals corresponding to the vehicle speed.

When you subsequently move the select

lever to the “R” position (AT and CVT models) or the shift lever to the reverse position (MT models), the rear wiper will switch to continuous operation. When you move the select lever/shift lever from the “R” (reverse) position to another position, the rear wiper will return to intermittent operation.

▼ Washer

To wash the rear window while the rear wiper is operating, turn the knob on the end of the wiper control lever upward to the position. The washer fluid sprays until you release the knob.

To wash the rear window when the rear wiper is not in use, turn the knob on the end of the wiper control lever downward to the position. The washer fluid sprays and the wiper operates until you release the knob.

Defogger and deicer

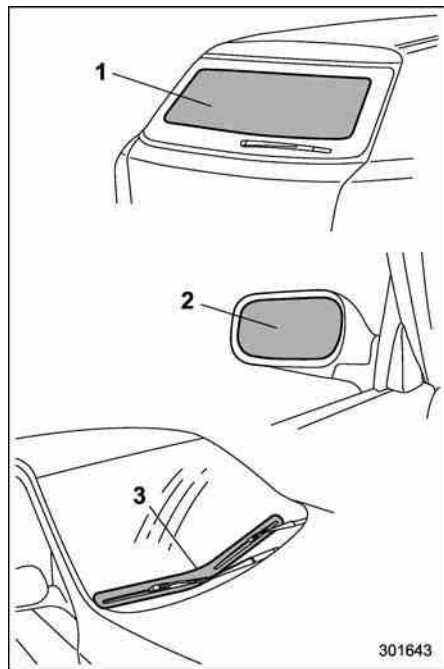

- 1) Rear window defogger
- 2) Outside mirror defogger (if equipped)
- 3) Windshield wiper deicer (if equipped)

The vehicle is equipped with a rear

window defogger. Some models are also equipped with an outside mirror defogger and/or windshield wiper deicer. The defogger and deicer system is activated only when the ignition switch is in the “ON” position.

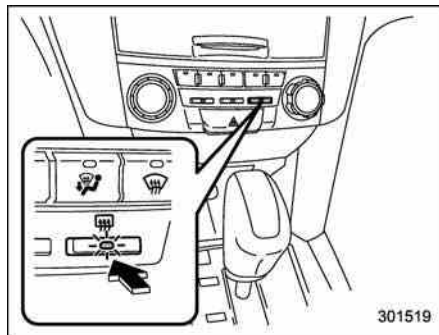

Control switch (type A)

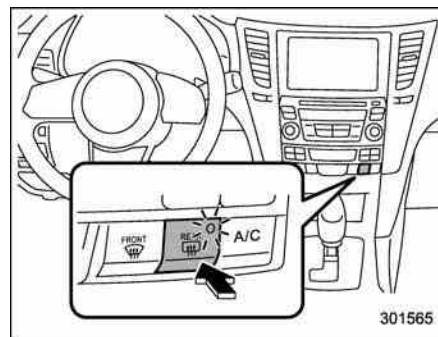

Control switch (type B)

To activate the defogger and deicer system, press the control switch. The rear window defogger, outside mirror defogger and windshield wiper deicer are activated simultaneously. The indicator light on the control switch illuminates while the defogger and deicer system is activated.

To turn them off, press the control switch again. They also turn off when the ignition switch is turned to the “Acc” or “LOCK” position.

The defogger and deicer system will automatically shut off after approximately 15 minutes. If the rear window and outside mirrors have been cleared and the windshield wiper blades have been deiced completely before that time, press the control switch to turn them off. If defrost-

ing, defogging or deicing is not complete, you have to press the control switch to turn them on again.

For models with the automatic climate control system, it is possible for a SUBARU dealer to set the defogger and deicer system for the continuous operation mode. Contact your SUBARU dealer for details.

CAUTION

- To prevent the battery from being discharged, do not operate the defogger and deicer system continuously for any longer than necessary.
- Do not use sharp instruments or window cleaner containing abrasives to clean the inner surface of the rear window. They may damage the conductors printed on the window.

NOTE

- Turn on the defogger and deicer system if the wipers are frozen to the windshield.
- If the windshield is covered with snow, remove the snow so that the windshield wiper deicer works effectively.
- While the defogger and deicer system is in the continuous operation mode, if the vehicle speed remains at 9 mph (15 km/h) or lower for 15 minutes, the windshield wiper deicer automatically stops operating, though the rear window defogger and outside mirror defogger maintain continuous operation in this condition.
- While the defogger and deicer system is in the continuous operation mode, if the battery voltage drops below the permissible level, continuous operation of the defogger and deicer system is canceled and the system stops operating.

Mirrors

Always check that the inside and outside mirrors are properly adjusted before you start driving.

■ **Type A inside mirror (if equipped)**

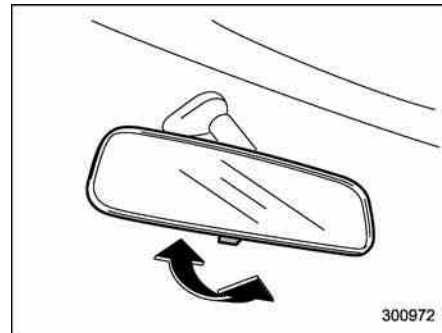

The mirror has a day and night position. Pull the tab at the bottom of the mirror toward you for the night position. Push it away for the day position. The night position reduces glare from headlights.

■ Type B inside mirror (if equipped)

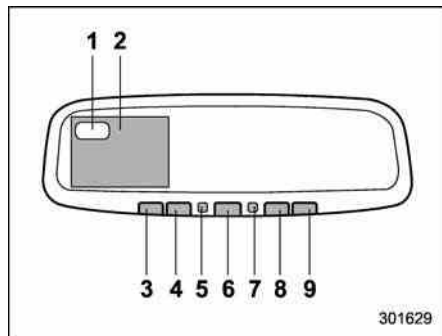

- 1) Electronic compass display
- 2) Rear view image display
- 3) HomeLink® button 1
- 4) HomeLink® button 2
- 5) Function indicator
- 6) HomeLink® button 3
- 7) Photosensor
- 8) Power button
- 9) Compass button

The mirror has the following features.

- Auto-dimming function for anti-glare capability
- Rear view image display
- Electronic compass display
- HomeLink® Wireless Control System

Using the power button and compass

button, you can display the various functions of the rear view image display and the electronic compass display based on how long you press the buttons.

Power button

Gear position	Period of time button is pressed	Function displayed
Except R (reverse)	Briefly	Auto-dimming function ON/OFF*
R (reverse)	Briefly	Rear view image display: ON/OFF* mode
	6 to 12 seconds	Enter the language selection mode
	12 to 15 seconds	Rear view image display: operational/non-operational mode

*: The setting returns to "ON" as a default setting every time the ignition switch is turned to the "OFF" position.

Compass button

Gear position	Period of time button is pressed	Function displayed
Except R (reverse)	Briefly	Electronic compass display ON/OFF
	3 to 6 seconds	Enter the compass zone setting mode
	6 to 9 seconds	Enter the compass calibration mode

▼ Auto-dimming function

The auto-dimming function is an anti-glare capability which automatically reduces glare coming from headlights of vehicles behind you.

By pressing the power button, the auto-dimming function is toggled on or off. When the auto-dimming function is on, the function indicator will illuminate in green.

Even with the mirror in anti-glare mode, the mirror surface turns bright if the transmission is shifted into the "R" (reverse) position. This is to ensure good rearward visibility during reversing.

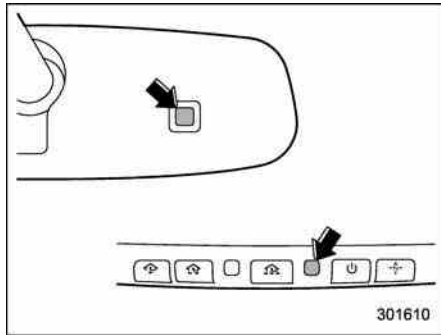

The mirror has a photosensor attached on both the front and back sides. During nighttime driving, these sensors detect distracting glare from vehicle headlights behind you and automatically dim the mirror to eliminate glare and preserve your vision. For this reason, use care not to cover the sensors with stickers, or other similar items. Periodically wipe the sensors clean using a piece of dry soft cotton cloth or an applicator.

NOTE

When cleaning the mirror, use a paper towel or similar item dampened with glass cleaner. Do not spray glass cleaner directly on the mirror surface. By doing so, the sprayed glass cleaner could enter the inside of the mirror

housing. That may cause a malfunction in the mirror.

▼ Rear view image display

When the ignition switch is in the “ON” position and the transmission is in the “R” (reverse) position, the rear view camera automatically displays the rear view image behind the vehicle on the inside mirror.

Also, the following help lines are indicated as a guide to help you realize the actual distance from the display.

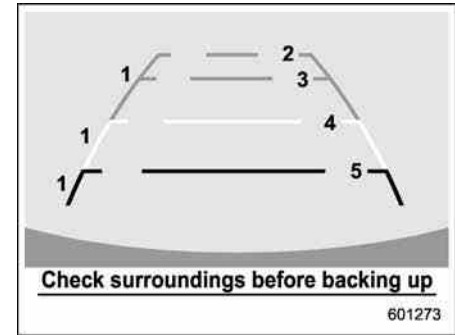

- 1) Vehicle width line (oblique vertical line)
- 2) Approx. 10 feet (3 m) from the bumper (green horizontal line)
- 3) Approx. 6.5 feet (2 m) from the bumper (green horizontal line)
- 4) Approx. 3 feet (1 m) from the bumper (yellow horizontal line)
- 5) Approx. 1.5 feet (0.5 m) from the bumper (red horizontal line)

By pressing the power button while the transmission is in the “R” (reverse) position, the rear view image display toggles to the on or off mode.

Once the rear view image display is set to the off mode, the display stays in the off mode, with the function indicator in orange, every time the transmission is shifted into the “R” (reverse) position.

If the ignition switch is turned to the “OFF” position, the display setting returns to the on mode as a default setting the next time the ignition switch is turned to the “ON” position.

▽ Language mode change

The language mode of the captions on the rear view image display is selectable in English or French in the following ways.

1. Press and hold the power button for 6 to 12 seconds while the transmission is in the “R” (reverse) position, and then release it. The display will enter the language selection mode.
2. Briefly press the power button to toggle the captions on the display in English or French.
3. By releasing the power button for 5 seconds, the display blinks one time to show that the language mode is selected.

▽ Non-operational mode

The rear view image display can be set as non-operational. After setting the display to the non-operational mode, the display does not show the rear view image even if the ignition switch is reset (turning the ignition switch to the “ON” position after turning it to the “OFF” position).

To set the display to the non-operational

mode, press and hold the power button for 12 to 15 seconds while the transmission is in the “R” (reverse) position, and then release it. The display is now in the non-operational mode. After the display has been set to the non-operational mode, the function indicator will illuminate in orange while the transmission is in the “R” (reverse) position.

To return the display to the operational mode, press and hold the power button for 12 to 15 seconds again.

For precautions about the rear view camera and the rear view image, refer to “Rear view camera” 6-19.

▼ Electronic compass display

By briefly pressing the compass button, the compass display is toggled on or off. When the compass display is on, an illuminated compass reading will appear on the mirror.

Using the electronic compass properly, the following compass zone adjustment and compass calibration will be necessary.

▽ Compass zone adjustment

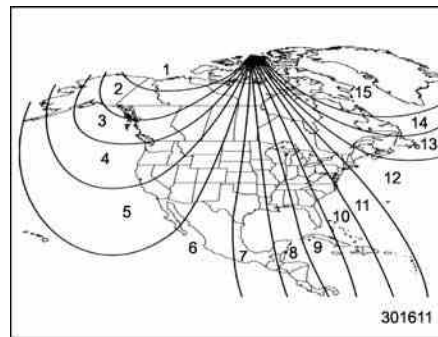

Compass calibration zones

1. Refer to the “Compass calibration zones” map shown above to verify that the compass zone setting is correct for your geographical location.
2. Press and hold the compass button for 3 to 6 seconds, and then release it. The zone number will be shown on the electronic compass display.
3. Press the compass button repeatedly until the correct zone number for your location is displayed.
4. Releasing the button for 3 seconds will exit the zone setting mode.

▽ Compass calibration

1. For optimum calibration, switch off all nonessential electrical accessories (rear window defogger, heater/air conditioning system, spotlight, etc.) and ensure all doors are shut.
2. Drive to an open, level area away from large metallic objects or structures and make certain the ignition switch is in the "ON" position.
3. Press and hold the compass button for 6 to 9 seconds, and then release it. The compass will enter the calibration mode, then "C" and the direction will be displayed.
4. Drive slowly in a circle until "C" disappears from the display. Driving in two or three circles might be necessary. The compass is now calibrated.
5. Further calibration may be necessary should outside influences cause the compass to read inaccurately. You will notice any outside influence if the compass tends to read in only one particular direction. Should you encounter this situation, return to step 1 of the above procedure and recalibrate the compass.

▼ HomeLink® Wireless Control System

The HomeLink® Wireless Control System can be used to activate remote control devices such as gate operators, garage door openers, door locks, home lighting and security systems.

There are three HomeLink® buttons on the mirror, each of which can be programmed for operation of one desired device. For details on the device types which can be operated by this system, consult the HomeLink® website at: www.homelink.com or call 1-800-355-3515.

Note the following information about this system.

If your vehicle is equipped with the HomeLink® Wireless Control System, it complies with Part 15 of the Federal Communications Commission Rules in the U.S. and the RSS-210 of Industry Canada in Canada. Its operation is subject to the following two conditions:

(1) this device may not cause harmful interference, and (2) this device must accept any interference received, including interference that may cause undesired operation.

Changes and modifications to this system

by anyone other than an authorized service facility could void authorization to use this equipment.

HomeLink® and the HomeLink® house are registered trademarks of Johnson Controls, Inc.



WARNING

- **When programming the HomeLink® Wireless Control System, you may be operating a garage door opener or other device. Make sure that people and objects are out of the way of the garage door or other device to prevent potential harm or damage.**
- **Do not use the HomeLink® Wireless Control System with a garage door opener that lacks the safety stop and reverse feature as required by applicable safety standards. A garage door opener which cannot detect an object, signaling the door to stop and reverse, does not meet these safety standards. Using a garage door opener without these features increases risk of serious injury or death. For more information, consult the HomeLink®.**

website at www.homelink.com or call 1-800-355-3515.

 **CAUTION**

When programming the HomeLink® Wireless Control System to operate a garage door opener or an entrance gate, unplug the device's motor from the outlet during programming to prevent motor burnout.

NOTE

- After programming your HomeLink® Wireless Control System for the desired devices, retain the hand-held transmitters for further programming or device testing in the event of a problem.
- It is recommended that you insert a new battery in the hand-held transmitter of a device to ensure correct programming.

▽ Garage door opener programming in the U.S.A.

NOTE

When programming the HomeLink® Wireless Control System for a garage door opener, it is suggested that you

park the vehicle outside the garage.

1. Unplug the motor of the garage door opener from the outlet.

NOTE

If any of the HomeLink® buttons are already programmed for other devices, skip step 2 because it clears the memory of all three buttons.

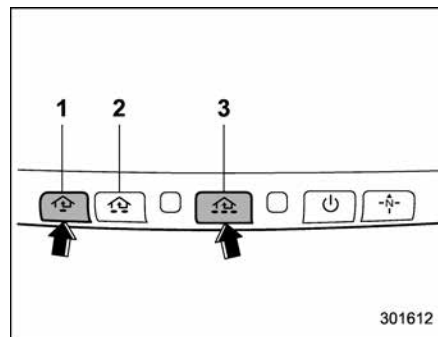

- 1) HomeLink® button 1
- 2) HomeLink® button 2
- 3) HomeLink® button 3

2. Press and hold the two outer HomeLink® buttons (button 1 and button 3) until the indicator light begins to flash (after approximately 20 seconds). Then release both buttons.

3. Hold the end of the garage door opener's hand-held transmitter between 1 and 3 inches (25 and 76 mm) away from the HomeLink® button you wish to program.

4. Simultaneously press and hold both the hand-held transmitter button and the desired HomeLink® button. DO NOT release the buttons until step 5 has been completed.

NOTE

Some gate operators and garage door openers may require you to replace this programming step 4 with procedures in “Programming for entrance gates and garage door openers in Canada” 3-42.

5. Hold down both buttons until the HomeLink® indicator light flashes, first slowly then rapidly. When the indicator light flashes rapidly, both buttons may be released. (The rapidly flashing light indicates successful programming of the new frequency signal.)

6. Press and hold the programmed button and check the HomeLink® indicator light. If the indicator light stays on continuously, your garage door opener should activate and the programming is completed.

If the indicator light flashes rapidly for 2 seconds and then stays on continuously, your garage door opener may be protected by a rolling code feature. In this case you need to perform the additional steps that are described in “Programming rolling-code-protected garage door openers in the U.S.A.” 3-41.

▽ **Programming rolling-code-protected garage door openers in the U.S.A.**

If your garage door opener has a rolling code feature, program the HomeLink® Wireless Control System for it by following steps 1 through 5 in “Garage door opener programming in the U.S.A.” 3-40. Then continue with the following steps.

NOTE

The assistance of a second person may make the programming quicker and easier.

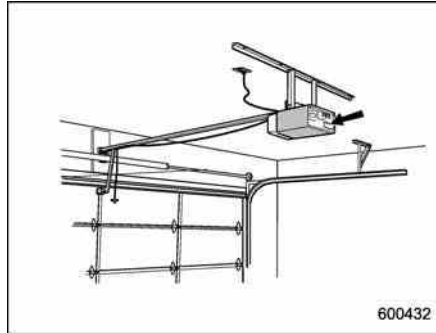

1. Locate the training button on the garage door opener motor head unit. The exact location and color of the button may vary by brand of garage door opener. If it is difficult to locate the training button, refer to your garage door opener’s instruc-

tion manual.

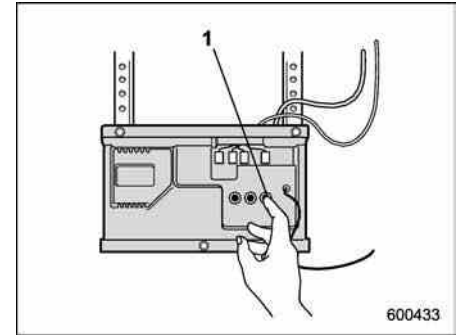

1) Training button

2. Press the training button on the garage door opener motor head unit (which activates the “training light” on the unit). Proceed to step 3 within 30 seconds.

3. Inside the vehicle, firmly press, hold for 2 seconds and release the HomeLink® button that was programmed in the previous section. Press and release the button a second time to complete the programming procedure.

NOTE

Some garage door openers may require you to do the above press-hold-release sequence a third time to complete the programming.

4. The garage door opener should now recognize the HomeLink® Wireless Control System and your garage door opener should activate when the HomeLink® button is pressed.

▽ Programming for entrance gates and garage door openers in Canada

1. Unplug the motor of the entrance gate or garage door opener from the outlet.

NOTE

If any of the HomeLink® buttons are already programmed for other devices, skip step 2 because it clears the memory of all three buttons.

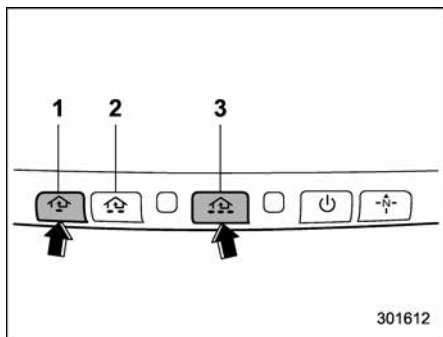

- 1) HomeLink® button 1
- 2) HomeLink® button 2
- 3) HomeLink® button 3

2. Press and hold the two outer HomeLink® buttons (button 1 and button 3) until the HomeLink® indicator light begins to flash (after approximately 20 seconds). Then release both buttons.

3. Hold the end of the entrance gate's/garage door opener's hand-held transmitter between 1 and 3 inches (25 and 76 mm) away from the HomeLink® button you wish to program.

4. Press and hold the desired HomeLink® button.

5. Press and release ("cycle") the hand-held transmitter button every 2 seconds until step 6 is complete.

6. When the indicator light flashes slowly and then rapidly after several seconds, release both buttons.

7. Plug the motor of the entrance gate/garage door opener to the outlet.

8. Test your entrance gate/garage door opener by pressing the programmed HomeLink® button.

▽ Operating the HomeLink® Wireless Control System

Once programmed, the HomeLink® Wireless Control System can be used to remote-control the devices to which its buttons are programmed. To activate a device, simply press the appropriate button. The indicator light illuminates, indicating that the signal is being transmitted.

▽ Programming other devices

To program other devices such as door locks, home lighting and security systems, contact HomeLink® at www.homelink.com or call 1-800-355-3515.

▽ Reprogramming a single HomeLink® button

1. Press and hold the HomeLink® button you wish to reprogram. DO NOT release the button until step 4 has been completed.

2. When the HomeLink® indicator light

begins to flash slowly (after approximately 20 seconds), position the hand-held transmitter of the device between 1 to 3 inches (25 to 76 mm) away from the HomeLink® button you wish to program.

3. Press and hold the hand-held transmitter button. The HomeLink® indicator light will flash, first slowly and then rapidly.
4. When the indicator light begins to flash rapidly, release both buttons.

The programming for the previous device is now erased and the new device can be operated by pressing the HomeLink® button.

▽ Erasing HomeLink® button memory

NOTE

- Performing this procedure erases the memory of all the preprogrammed buttons simultaneously. The memory of individual buttons cannot be erased.
- It is recommended that upon the sale of the vehicle, the memory of all programmed HomeLink® buttons be erased for security purposes.

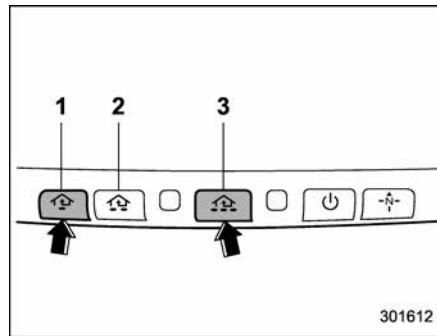

- 1) HomeLink® button 1
- 2) HomeLink® button 2
- 3) HomeLink® button 3

1. Press and hold the two outer buttons (button 1 and button 3) until the indicator light begins to flash (after approximately 20 seconds).
2. Release both buttons.

▽ In case a problem occurs

If you cannot activate a device using the corresponding HomeLink® button after programming, contact HomeLink® at www.homelink.com or call 1-800-355-3515 for assistance.

■ Auto-dimming mirror with compass (if equipped)

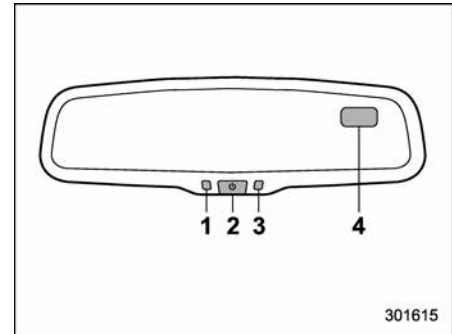

- 1) LED
- 2) Switch
- 3) Sensor
- 4) Compass display

The auto-dimming mirror has an anti-glare feature which automatically reduces glare coming from headlights of vehicles behind you. It also contains a built-in compass.

- By pressing and holding the switch for less than 3 seconds, the automatic dimming function is toggled on or off. When the automatic dimming function is on, the LED indicator will illuminate.

Even with the mirror in anti-glare mode, the mirror surface turns bright if the transmission is shifted into reverse. This

is to ensure good reward visibility during reversing.

- By pressing and releasing the switch for 3 seconds, the compass display is toggled on or off. When the compass is on, an illuminated compass reading will appear in the upper right corner of the mirror.

When cleaning the mirror, use a paper towel or similar material dampened with glass cleaner. Do not spray glass cleaner directly on the mirror as that may cause the liquid cleaner to enter the mirror housing and damage the mirror.

▼ Photosensors

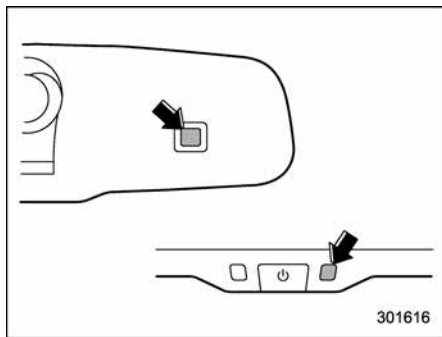

The mirror has a photosensor attached on the front and back sides. During nighttime driving, these sensors detect distracting

glare from vehicle headlights behind you and automatically dim the mirror to eliminate glare and preserve your vision. For this reason, use care not to cover the sensors with stickers, or other similar items. Periodically wipe the sensors clean using a piece of dry soft cotton cloth or an applicator.

▼ Compass zone adjustment

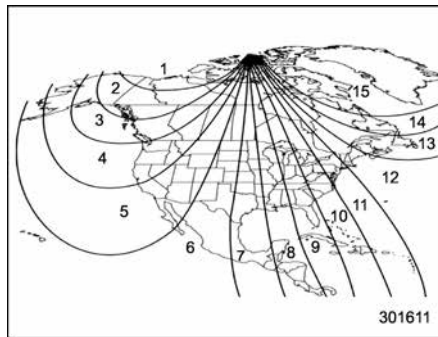

Compass calibration zones

1. Refer to the "Compass calibration zones" map shown above to verify that the compass zone setting is correct for your geographical location.
2. Press and hold the switch for 6 seconds until the zone selection comes up (a number will be displayed in the mirror compass window).

3. Press the switch repeatedly until the correct zone setting for your location is displayed.

4. Releasing the button for 10 seconds will exit the zone setting mode.

▼ Compass calibration

1. If a "C" is displayed in the compass window, the compass needs to be calibrated.

2. Drive the vehicle in a circle at 5 mph (8 km/h) or less until the display reads a direction.

3. You can also calibrate the compass by driving your vehicle on your everyday routine. The compass will be calibrated once it has tracked a complete circle.

4. To recalibrate your compass, push and hold the switch for 9 seconds until a "C" appears in the compass window.

5. Calibrate the compass according to step 2 or step 3.

■ Auto-dimming mirror with compass and HomeLink® (if equipped)

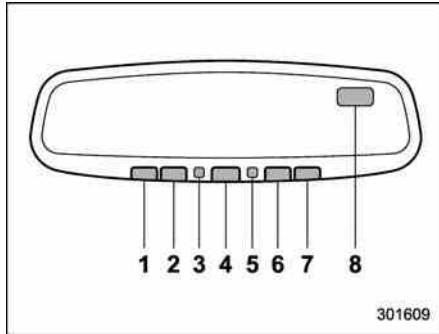

- 1) HomeLink® button 1
- 2) HomeLink® button 2
- 3) LED
- 4) HomeLink® button 3
- 5) Sensor
- 6) Automatic dimming on/off button
- 7) Compass display button
- 8) Compass display

The auto-dimming mirror has an anti-glare feature which automatically reduces glare coming from headlights of vehicles behind you. It also contains a built-in compass and HomeLink® wireless control system.

- By pressing the automatic dimming on/off button, the automatic dimming function is toggled on or off. When the automatic

dimming function is on, the LED indicator will illuminate.

Even with the mirror in the automatic dimming mode, the mirror surface turns bright if the transmission is shifted into reverse. This is to ensure good rearward visibility during reversing.

- By pressing the compass display button, the compass display is toggled on or off. When the compass is on, an illuminated compass reading will appear in the upper right corner of the mirror.

When cleaning the mirror, use a paper towel or similar material dampened with glass cleaner. Do not spray glass cleaner directly on the mirror as that may cause the liquid cleaner to enter the mirror housing and damage the mirror.

▼ Photosensors

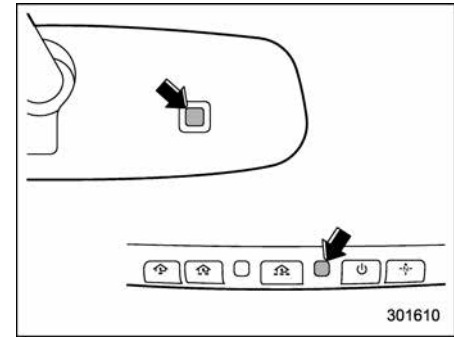

The mirror has a photosensor attached on both the front and back sides. During nighttime driving, these sensors detect distracting glare from vehicle headlights behind you and automatically dim the mirror to eliminate glare and preserve your vision. For this reason, use care not to cover the sensors with stickers, or other similar items. Periodically wipe the sensors clean using a piece of dry soft cotton cloth or an applicator.

▼ **Compass zone adjustment**

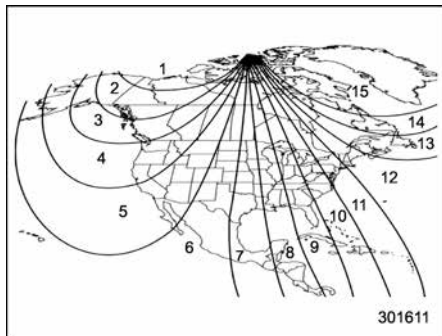

Compass calibration zones

1. Refer to the “Compass calibration zones” map shown above to verify that the compass zone setting is correct for your geographical location.
2. Press and hold the compass display button for 3 seconds until the zone selection comes up (a number will be displayed in the mirror compass window).
3. Press the compass display button repeatedly until the correct zone setting for your location is displayed.
4. Releasing the button for 5 seconds will exit the zone setting mode.

▼ **Compass calibration**

1. If a “C” is displayed in the compass window, the compass needs to be calibrated.
2. Drive the vehicle in a circle at 5 mph (8 km/h) or less until the display reads a direction.
3. You can also calibrate the compass by driving your vehicle on your everyday routine. The compass will be calibrated once it has tracked a complete circle.
4. To recalibrate your compass, push and hold the compass display button for 9 seconds until a “C” appears in the compass window.
5. Calibrate the compass according to step 2 or step 3.

▼ **HomeLink® Wireless Control System**

The HomeLink® Wireless Control System can be used to activate remote control devices such as gate operators, garage door openers, door locks, home lighting and security systems.

There are three HomeLink® buttons on the mirror, each of which can be programmed for operation of one desired device. For details on the device types which can be operated by this system, consult the HomeLink® website at:

www.homelink.com or call 1-800-355-3515.

Note the following information about this system.

If your vehicle is equipped with the HomeLink® Wireless Control System, it complies with Part 15 of the Federal Communications Commission Rules in the U.S. and the RSS-210 of Industry Canada in Canada. Its operation is subject to the following two conditions:

(1) this device may not cause harmful interference, and (2) this device must accept any interference received, including interference that may cause undesired operation.

Changes and modifications to this system by anyone other than an authorized service facility could void authorization to use this equipment.

HomeLink® and the HomeLink® house are registered trademarks of Johnson Controls, Inc.



WARNING

- **When programming the HomeLink® Wireless Control System, you may be operating a garage door opener or other device. Make sure that people**

and objects are out of the way of the garage door or other device to prevent potential harm or damage.

- Do not use the HomeLink® Wireless Control System with a garage door opener that lacks the safety stop and reverse feature as required by applicable safety standards. A garage door opener which cannot detect an object, signaling the door to stop and reverse, does not meet these safety standards. Using a garage door opener without these features increases risk of serious injury or death. For more information, consult the HomeLink® website at www.homelink.com or call 1-800-355-3515.

CAUTION

When programming the HomeLink® Wireless Control System to operate a garage door opener or an entrance gate, unplug the device's motor from the outlet during programming to prevent motor burnout.

NOTE

- After programming your HomeLink® Wireless Control System for the desired devices, retain the hand-held transmitters for further programming or device testing in the event of a problem.
- It is recommended that you insert a new battery in the hand-held transmitter of a device to ensure correct programming.

▽ Garage door opener programming in the U.S.A.

NOTE

When programming the HomeLink® Wireless Control System for a garage door opener, it is suggested that you park the vehicle outside the garage.

1. Unplug the motor of the garage door opener from the outlet.

NOTE

If any of the HomeLink® buttons are already programmed for other devices, skip step 2 because it clears the memory of all three buttons.

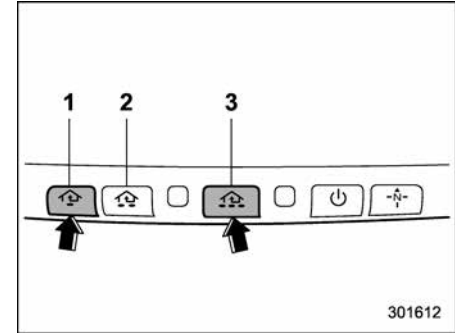

- 1) HomeLink® button 1
- 2) HomeLink® button 2
- 3) HomeLink® button 3

2. Press and hold the two outer HomeLink® buttons (button 1 and button 3) until the indicator light begins to flash (after approximately 20 seconds). Then release both buttons.

3. Hold the end of the garage door opener's hand-held transmitter between 1 and 3 inches (25 and 76 mm) away from the HomeLink® button you wish to program.

4. Simultaneously press and hold both the hand-held transmitter button and the desired HomeLink® button. DO NOT release the buttons until step 5 has been completed.

NOTE

Some gate operators and garage door openers may require you to replace this programming step 4 with procedures in “Programming for entrance gates and garage door openers in Canada” 3-49.

5. Hold down both buttons until the HomeLink® indicator light flashes, first slowly then rapidly. When the indicator light flashes rapidly, both buttons may be released. (The rapidly flashing light indicates successful programming of the new frequency signal.)

6. Press and hold the programmed button and check the HomeLink® indicator light. If the indicator light stays on continuously, your garage door should activate and the programming is completed.

If the indicator light flashes rapidly for 2 seconds and then stays on continuously, your garage door opener may be protected by a rolling code feature. In this case you need to perform the additional steps that are described in “Programming rolling-code-protected garage door openers in the U.S.A.” 3-48.

▽ **Programming rolling-code-protected garage door openers in the U.S.A.**

If your garage door opener has a rolling code feature, program the HomeLink® Wireless Control System for it by following steps 1 through 5 in “Garage door opener programming in the U.S.A.” 3-47. Then continue with the following steps.

NOTE

The assistance of a second person may make the programming quicker and easier.

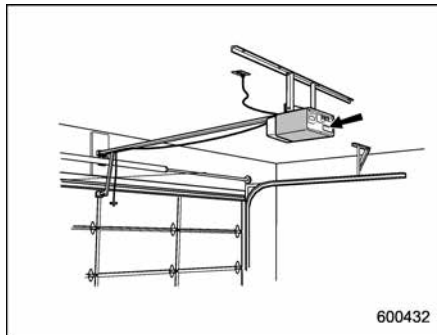

1. Locate the training button on the garage door opener motor head unit. The exact location and color of the button may vary by brand of garage door opener. If it is difficult to locate the training button, refer to your garage door opener’s instruc-

tion manual.

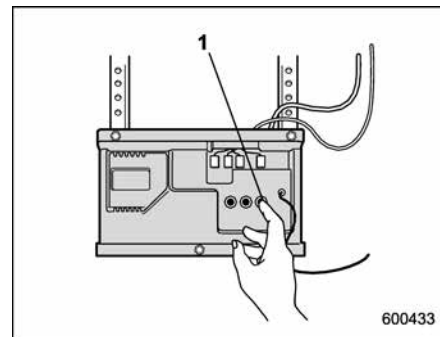

1) Training button

2. Press the training button on the garage door opener motor head unit (which activates the “training light” on the unit). Proceed to step 3 within 30 seconds.

3. Inside the vehicle, firmly press, hold for 2 seconds and release the HomeLink® button that was programmed in the previous section. Press and release the button a second time to complete the programming procedure.

NOTE

Some garage door openers may require you to do the above press-hold-release sequence a third time to complete the programming.

4. The garage door opener should now recognize the HomeLink® Wireless Control System and your garage door opener should activate when the HomeLink® button is pressed.

▽ Programming for entrance gates and garage door openers in Canada

1. Unplug the motor of the entrance gate or garage door opener from the outlet.

NOTE

If any of the HomeLink® buttons are already programmed for other devices, skip step 2 because it clears the memory of all three buttons.

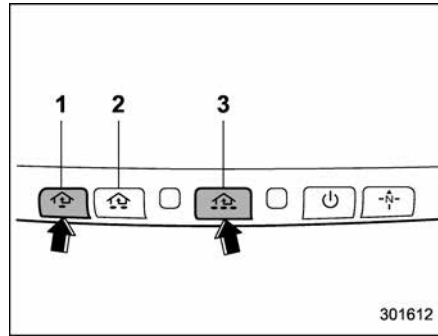

- 1) HomeLink® button 1
- 2) HomeLink® button 2
- 3) HomeLink® button 3

2. Press and hold the two outer HomeLink® buttons (button 1 and button 3) until the HomeLink® indicator light begins to flash (after approximately 20 seconds). Then release both buttons.

3. Hold the end of the entrance gate's/ garage door opener's hand-held transmitter between 1 and 3 inches (25 and 76 mm) away from the HomeLink® button you wish to program.

4. Press and hold the desired HomeLink® button.

5. Press and release ("cycle") the hand-held transmitter button every 2 seconds until step 6 is complete.

6. When the indicator light flashes slowly and then rapidly after several seconds, release both buttons.

7. Plug the motor of the entrance gate/ garage door opener to the outlet.

8. Test your entrance gate/garage door opener by pressing the programmed HomeLink® button.

▽ Operating the HomeLink® Wireless Control System

Once programmed, the HomeLink® Wireless Control System can be used to remote-control the devices to which its buttons are programmed. To activate a device, simply press the appropriate button. The indicator light illuminates, indicating that the signal is being transmitted.

▽ Programming other devices

To program other devices such as door locks, home lighting and security systems, contact HomeLink® at www.homelink.com or call 1-800-355-3515.

▽ Reprogramming a single HomeLink® button

1. Press and hold the HomeLink® button you wish to reprogram. DO NOT release the button until step 4 has been completed.

2. When the HomeLink® indicator light

begins to flash slowly (after approximately 20 seconds), position the hand-held transmitter of the device between 1 to 3 inches (25 to 76 mm) away from the HomeLink® button you wish to program.

3. Press and hold the hand-held transmitter button. The HomeLink® indicator light will flash, first slowly and then rapidly.
4. When the indicator light begins to flash rapidly, release both buttons.

The programming for the previous device is now erased and the new device can be operated by pressing the HomeLink® button.

▽ Erasing HomeLink® button memory

NOTE

- **Performing this procedure erases the memory of all the preprogrammed buttons simultaneously. The memory of individual buttons cannot be erased.**
- **It is recommended that upon the sale of the vehicle, the memory of all programmed HomeLink® buttons be erased for security purposes.**

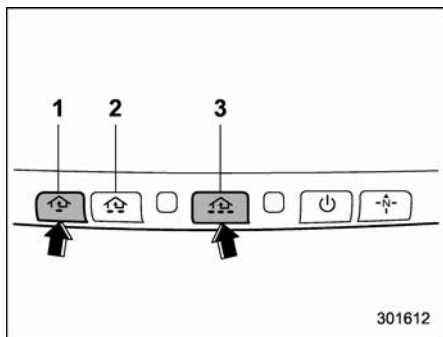

- 1) HomeLink® button 1
- 2) HomeLink® button 2
- 3) HomeLink® button 3

1. Press and hold the two outer buttons (button 1 and button 3) until the indicator light begins to flash (after approximately 20 seconds).
2. Release both buttons.

▽ In case a problem occurs

If you cannot activate a device using the corresponding HomeLink® button after programming, contact HomeLink® at www.homelink.com or call 1-800-355-3515 for assistance.

■ Outside mirrors

▼ Convex mirror (passenger side)



Objects look smaller in a convex mirror and farther away than when viewed in a flat mirror. Do not use the convex mirror to judge the distance of vehicles behind you when changing lanes. Use the inside mirror (or glance backwards) to determine the actual size and distance of objects that you view in convex mirror.

▼ Remote control mirror switch

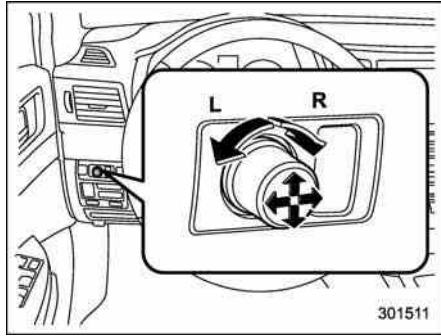

The remote control mirrors operate only when the ignition switch is in the "ON" or "Acc" position.

1. Turn the knob to the "L" side to adjust the left-hand mirror or to the "R" side to adjust the right-hand mirror.
2. Move the knob in the direction you want to move the mirror.
3. Return the knob to the neutral position to prevent unintentional operation.

The mirrors can also be adjusted manually.

▼ Power folding mirror switch (if equipped)

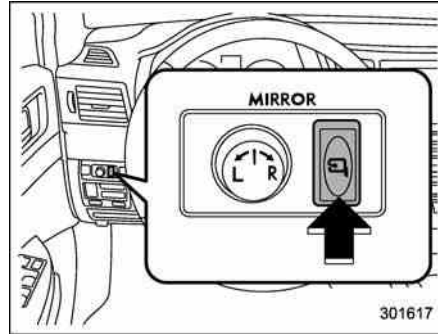

The power folding mirror switch operates only when the ignition switch is in the "ON" or "Acc" position.

To fold the outside mirrors, push the power folding mirror switch. To unfold the mirrors, push the switch again.

NOTE

- When the temperature is low, the outside mirrors may stop during operation. Push the switch again. When the outside mirrors do not work by operating the switch, move the outside mirrors several times manually. This makes it possible to operate them by switch operation.
- When you operate the power folding

mirror switch continuously, it may not work. This is not a malfunction. Operate after waiting for a short period of time.

- When you unfold the outside mirrors manually, the mirrors may become wobbly. Be sure to unfold the mirrors by operating the switch. If the outside mirrors are still wobbly, fold the mirrors again and then unfold them by operating the switch again.

Tilt/telescopic steering wheel

 **WARNING**

Do not adjust the steering wheel tilt/telescopic position while driving. This may cause loss of vehicle control and result in personal injury.

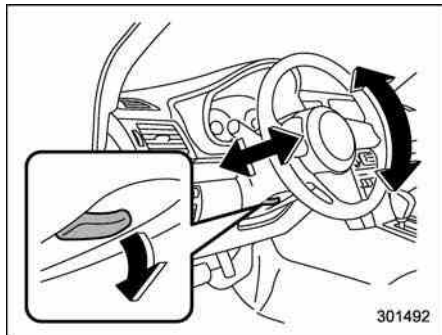

1. Adjust the seat position. Refer to “Front seats” 1-2.
2. Pull the tilt/telescopic lock lever down.
3. Move the steering wheel to the desired level.
4. Pull the lever up to lock the steering wheel in place.
5. Make sure that the steering wheel is securely locked by moving it up and down,

and forward and backward.

Horn

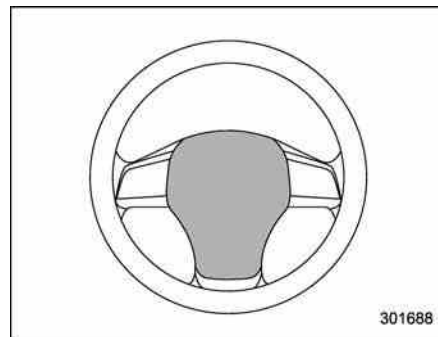

To sound the horn, push the horn pad.



Ventilator control	4-2	Operating tips for heater and air conditioner	4-8
Center ventilators.....	4-2	Cleaning ventilator grille	4-8
Side ventilators	4-2	Efficient cooling after parking in direct sunlight.....	4-8
Climate control panel	4-3	Lubrication oil circulation in the refrigerant circuit.....	4-9
Type A	4-3	Checking air conditioning system before summer season	4-9
Type B	4-4	Cooling and dehumidifying in high humidity and low temperature weather condition.....	4-9
Automatic climate control system (type B)	4-5	Air conditioner compressor shut-off when engine is heavily loaded.....	4-9
Temperature sensors.....	4-5	Refrigerant for your climate control system	4-9
Manual climate control	4-6	Air filtration system	4-9
Airflow mode selection	4-6	Replacing an air filter.....	4-10
Temperature control	4-7		
Fan speed control	4-7		
Air conditioner control	4-7		
Air inlet selection	4-7		
Defrosting	4-8		

Ventilator control

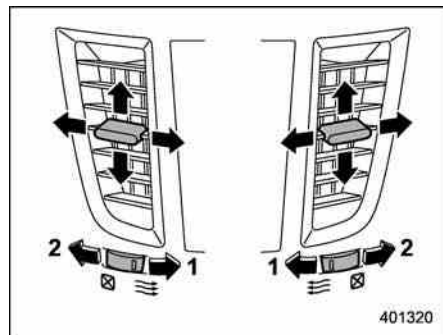
■ Center ventilators





- 1) Open
- 2) Close

Move the tab to adjust the flow direction.
To open the ventilator, turn the center grille open/close wheel to the “” position.
To close it, turn the wheel to the “” position.

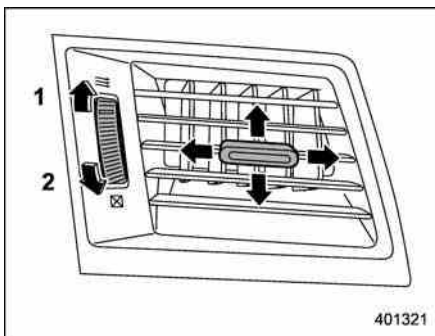
■ Side ventilators



- 1) Open
- 2) Close

Move the tab to adjust the flow direction.
To open the ventilator, turn the side grille open/close wheel upward to the “” position.
To close it, turn the wheel downward to the “” position.

Climate control panel

■ Type A

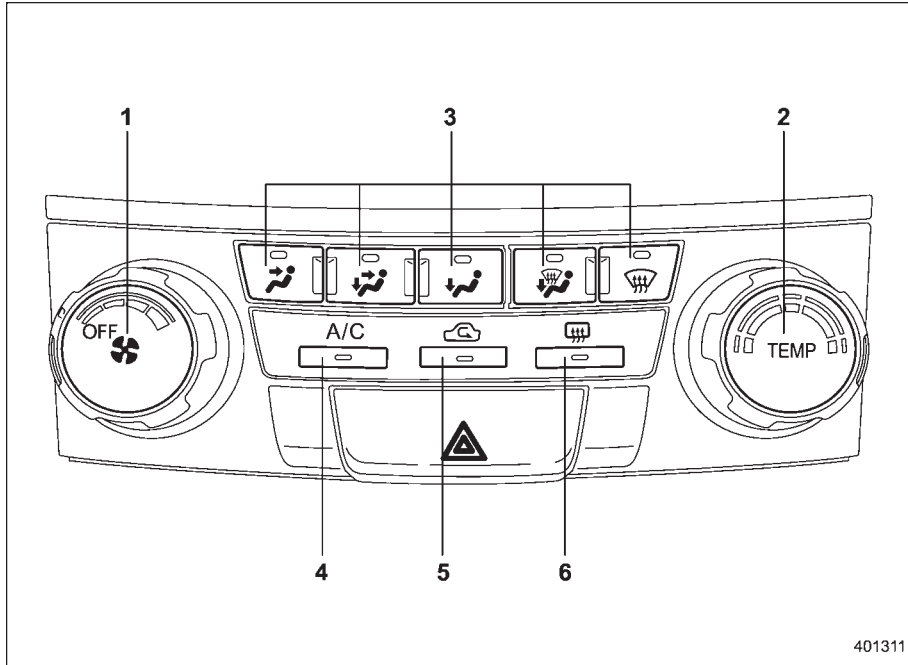

- 1) Fan speed control dial (Refer to “Fan speed control” 4-7.)
- 2) Temperature control dial (Refer to “Temperature control” 4-7.)
- 3) Airflow control buttons (Refer to “Airflow mode selection” 4-6.)
- 4) Air conditioner button (Refer to “Air conditioner control” 4-7.)
- 5) Air inlet selection button (Refer to “Air inlet selection” 4-7.)
- 6) Rear window defogger button (Refer to “Defogger and deicer” 3-34.)

401311

■ Type B

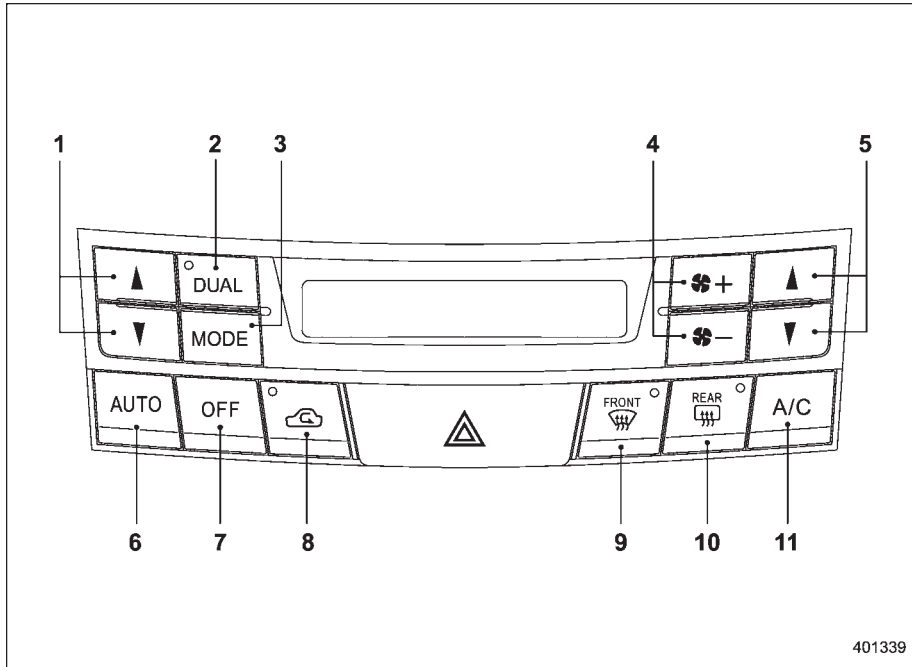

- 1) Temperature control button (driver's side) (Refer to "Temperature control" ¶4-7.)
- 2) Dual mode button (Refer to "Automatic climate control system (type B)" ¶4-5 and "Temperature control" ¶4-7.)
- 3) Airflow mode selection button (Refer to "Airflow mode selection" ¶4-6.)
- 4) Fan speed control button (Refer to "Fan speed control" ¶4-7.)
- 5) Temperature control button (front passenger's side) (Refer to "Temperature control" ¶4-7.)
- 6) AUTO button (Refer to "Automatic climate control system (type B)" ¶4-5.)
- 7) OFF button (Refer to "Automatic climate control system (type B)" ¶4-5.)
- 8) Air inlet selection button (Refer to "Air inlet selection" ¶4-7.)
- 9) Defroster button (Refer to "Airflow mode selection" ¶4-6 and "Defrosting" ¶4-8.)
- 10) Rear window defogger button (Refer to "Defogger and deicer" ¶3-34.)
- 11) Air conditioner button (Refer to "Air conditioner control" ¶4-7.)

Automatic climate control system (type B)

NOTE

- Operate the automatic climate control system when the engine is running.
- The blower fan rotates at a low speed when the engine coolant temperature is low.
- For efficient defogging or dehumidifying in cold weather, press the "A/C" button.

When the automatic climate control mode is selected, the following items are automatically controlled.

- Outlet air temperature
- Fan speed
- Airflow distribution
- Air inlet control
- Air conditioner compressor operation

To activate this mode, perform the following procedure.

1. Set the preferred temperature using the temperature control button.
2. Press the "AUTO" button. The FULL AUTO mode is selected and the "FULL AUTO" indicator light on the display illuminates.

NOTE

- When the "DUAL" button is pressed, separate temperature settings for the driver's side and passenger's side can be enabled (DUAL mode). To cancel the DUAL mode, press the "DUAL" button again. The temperature setting for the passenger's side becomes the same as the setting for the driver's side.
 - If you operate any of the buttons on the control panel other than the "OFF" button, rear window defogger button and temperature control buttons during FULL AUTO mode operation, the "FULL" indicator light on the control panel will turn off and the "AUTO" indicator light will remain illuminated. You can then manually control the system as desired. To change the system back to the FULL AUTO mode, press the "AUTO" button.
3. To turn off the climate control system, press the "OFF" button.

Temperature sensors

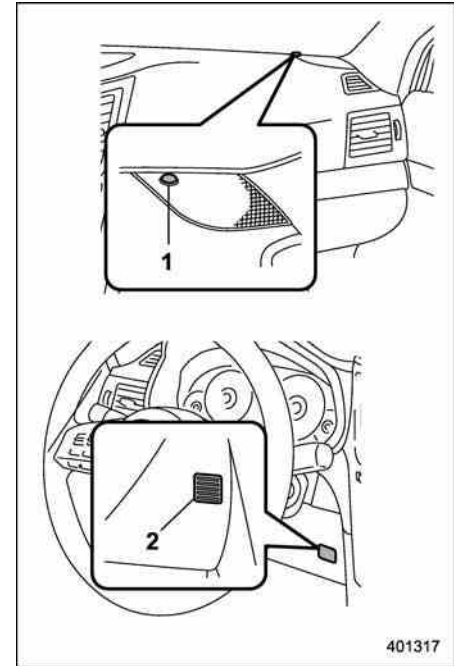

- 1) Solar sensor
- 2) Interior air temperature sensor

The automatic climate control system employs several sensors. These sensors are delicate. If they are treated incorrectly

and become damaged, the system may not be able to control the interior temperature correctly. To avoid damaging the sensors, observe the following precautions:

- Do not subject the sensors to impact.
- Keep water away from the sensors.
- Do not cover the sensors.

The sensors are located as follows:

- Solar sensor: beside the speaker grille on the dashboard
- Interior air temperature sensor: on the side of the driver-side part of the center panel
- Outside temperature sensor: behind front grille.

Manual climate control

■ Airflow mode selection

Select the preferred airflow mode by performing the following procedure.

- Press the preferred airflow control button (type A)
- Press the airflow mode selection button or defroster button (type B)

Airflow modes are as follows.

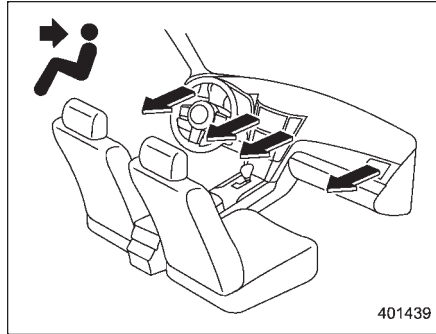

(Ventilation): Instrument panel outlets

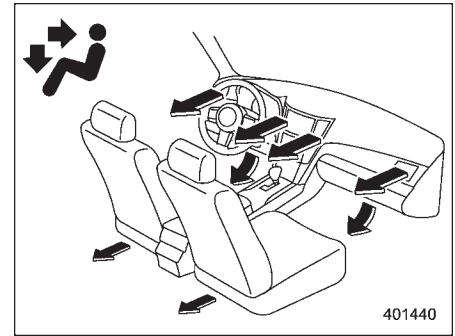

(Bi-level): Instrument panel outlets and the foot outlets

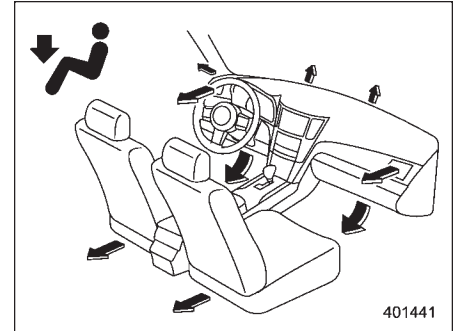

(Heat): Foot outlets, both side outlets of the instrument panel and some through windshield defroster outlets (A small amount of air flows to the windshield and

both side windows to prevent fogging.)

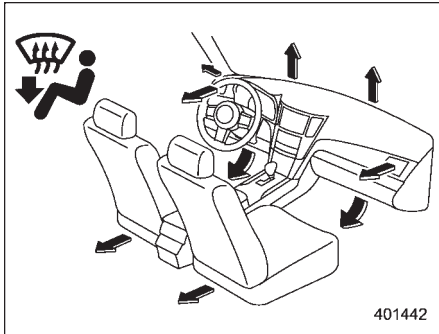

(Heat-def): Windshield defroster outlets, foot outlets and both side outlets of the instrument panel

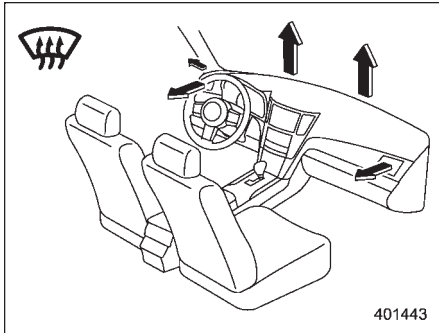

(Defrost): Windshield defroster outlets and both side outlets of the instrument panel

■ Temperature control

▼ Type A

Turn the temperature control dial over a range from the blue side (cool) to red side (warm) to regulate the temperature of airflow from the air outlets.

▼ Type B

To increase the temperature setting, press the “▲” side of the temperature control button. To decrease the temperature setting, press the “▼” side of the temperature control button.

Each temperature setting is shown on the display. When “LO” is shown, the system provides maximum cooling performance. When “HI” is shown, the system provides maximum heating performance.

NOTE

When the “DUAL” button is pressed, separate temperature settings for the driver’s side and passenger’s side can be enabled (DUAL mode). To cancel the DUAL mode, press the “DUAL” button again. The temperature setting for the passenger’s side becomes the same as the setting for the driver’s side.

■ Fan speed control

The fan operates only when the ignition

switch is in the “ON” position. Select the preferred fan speed by turning the fan speed control dial (type A), or by pressing the fan speed control buttons (type B).

■ Air conditioner control

The air conditioner operates only when the engine is running.

Press the air conditioner button while the fan is in operation to turn on the air conditioner. When the air conditioner is on, the indicator light on the air conditioner button (type A)/“A/C” indicator light (type B) illuminates.

To turn off the air conditioner, press the button again. The indicator light will turn off.

NOTE

For efficient defogging or dehumidifying in cold weather, turn on the air conditioner.

■ Air inlet selection

Select the air inlet by pressing the air inlet selection button.

ON position (recirculation): Interior air is recirculated inside the vehicle. Press the air inlet selection button to the ON position for fast cooling with the air conditioner or when driving on a dusty road. When the

ON position is selected, the indicator light on the air inlet selection button illuminates.

OFF position (outside air): Outside air is drawn into the passenger compartment. Press the air inlet selection button to the OFF position when the interior has cooled to a comfortable temperature and the road is no longer dusty. The indicator light will turn off.



WARNING

Continued operation in the ON position may fog up the windows. Switch to the OFF position as soon as the outside dusty condition clears.

Defrosting

Select the desired “” mode or “” mode to defrost or dehumidify the windshield and front door windows by performing the following procedures.

For type A: Press the airflow control button and select the “” mode or “” mode.

For type B: Press the airflow mode selection button to select the “” mode or press the defroster button to select the “” mode.

NOTE

When the “” mode or “” mode is selected, the air conditioner compressor automatically operates to more quickly defog the windshield. At the same time, the air inlet selection is automatically set to the outside air mode. For details, refer to “Airflow mode selection” 4-6.

Operating tips for heater and air conditioner

■ Cleaning ventilator grille

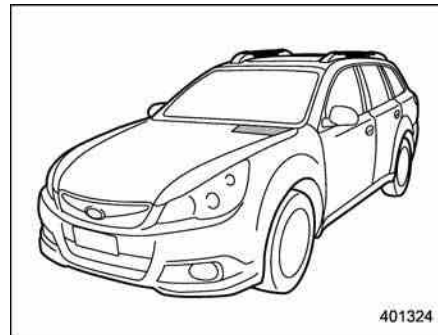

Always keep the front ventilator inlet grille free of snow, leaves, or other obstructions to ensure efficient heating and defrosting. Since the condenser is located in front of the radiator, this area should be kept clean because cooling performance is impaired by any accumulation of insects and leaves on the condenser.

■ Efficient cooling after parking in direct sunlight

After parking in direct sunlight, drive with the windows open for a few minutes to allow outside air to circulate into the

heated interior. This results in quicker cooling by the air conditioner. Keep the windows closed during the operation of the air conditioner for maximum cooling efficiency.

■ Lubrication oil circulation in the refrigerant circuit

Operate the air conditioner compressor at a low engine speed (at idle or low driving speeds) a few minutes each month during the off-season to circulate its oil.

■ Checking air conditioning system before summer season

Check the air conditioner unit for refrigerant leaks, hose conditions, and proper operation each spring. Have the air conditioning system checked by your SUBARU dealer.

■ Cooling and dehumidifying in high humidity and low temperature weather condition

Under certain weather conditions (high relative humidity, low temperatures, etc.) a small amount of water vapor emission from the air outlets may be noticed. This condition is normal and does not indicate any problem with the air conditioning

system.

■ Air conditioner compressor shut-off when engine is heavily loaded

To improve acceleration and gas mileage, the air conditioner compressor is designed to temporarily shut off during air conditioner operation whenever the accelerator is fully depressed such as during rapid acceleration or when driving on a steep upgrade.

■ Refrigerant for your climate control system

Your air conditioner uses ozone friendly refrigerant HFC134a. Therefore, the method of adding, changing or checking the refrigerant is different from the method for CFC12 (freon). Consult your SUBARU dealer for service. Repairs needed as a result of using the wrong refrigerant are not covered under warranty.

Air filtration system

Your vehicle's air conditioning system is equipped with an air filtration system. Replace the air filter element according to the replacement schedule shown in the following table. This schedule should be followed to maintain the filter's dust collection ability. Under extremely dusty conditions, the filter should be replaced more frequently. Have your filter checked or replaced by your SUBARU dealer. For replacement, use only a genuine SUBARU air filter kit.

Replacement schedule:

Every 15 months or 15,000 miles (24,000 km) whichever comes first



CAUTION

Contact your SUBARU dealer if the following occurs, even if it is not yet time to change the filter.

- Reduction of the airflow through the vents.
- Windshield gets easily fogged or misted.

NOTE

The filter can influence the air conditioning, heating and defroster performance if not properly maintained.

■ Replacing an air filter

1. Remove the glove box.
 - (1) Open the glove box.

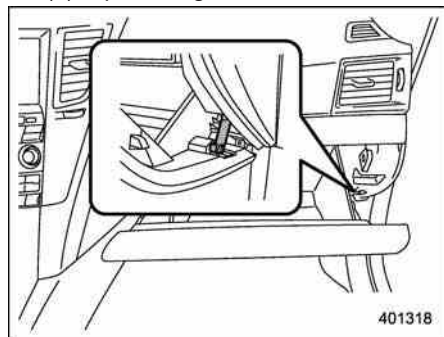

- (2) Remove the damper shaft from the glove box.

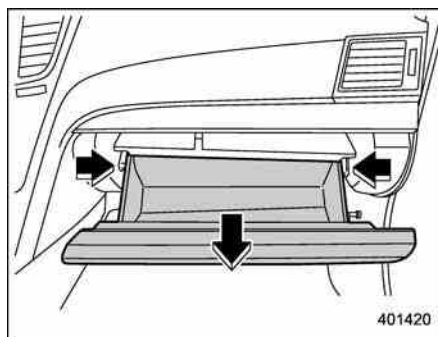

- (3) Pull out the glove box.

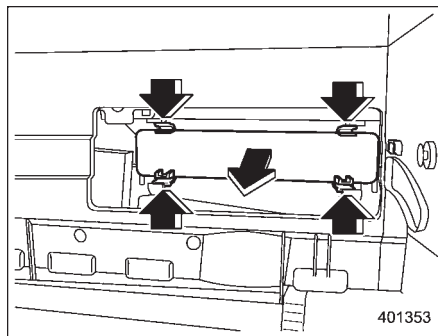

2. Remove the cover of the air filter.

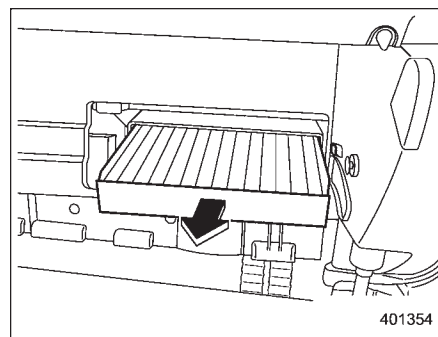

3. Remove the air filter.

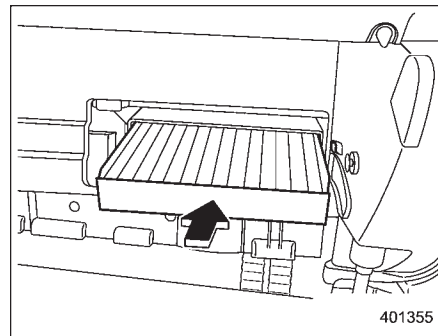

4. Replace the air filter element with a new one.
5. Reinstall the cover of the air filter.

CAUTION

The arrow mark on the filter must point UP.

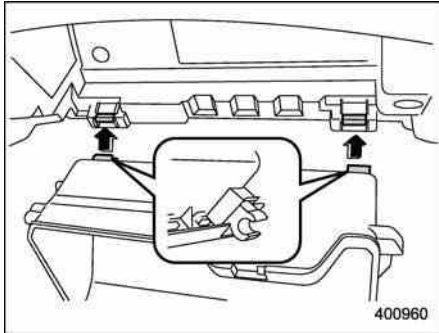

6. Reinstall the glove box, and connect the damper shaft.
7. Close the glove box.
8. LABEL installation
 - (1) Fill out the information on the service label (small).

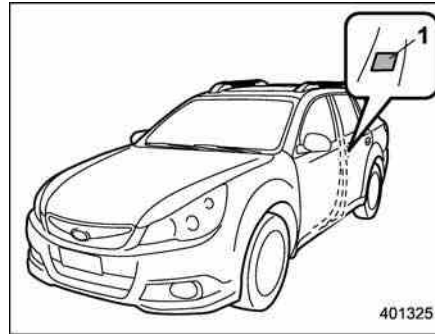

- 1) Service label
- (2) Attach the service label to the driver's side door pillar.

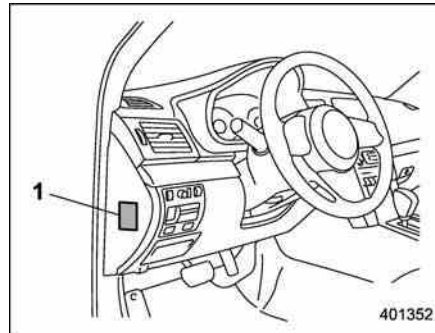

- 1) Caution label
- (3) Attach the caution label on the

driver's side of the instrument panel as shown in the illustration.

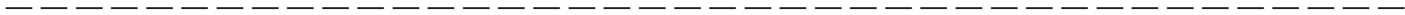
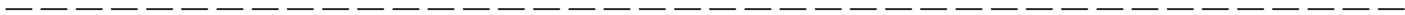
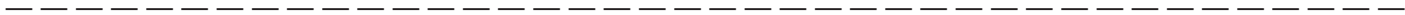
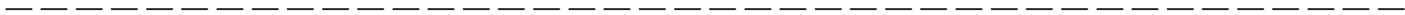
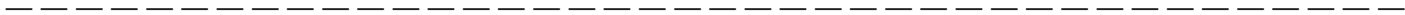

Antenna system	5-3	CD player operation	5-23
Printed antenna.....	5-3	Play file	5-23
FM reception.....	5-3	How to insert a CD	5-24
Installation of accessories	5-3	How to play back a CD	5-24
Audio set	5-4	To select a track from the beginning	5-24
Type A audio set (if equipped)	5-5	Fast-forwarding and rewinding	5-25
Type B audio set (if equipped)	5-6	Repeating	5-26
Type C audio set (if equipped)	5-7	Random playback	5-27
Power and audio controls	5-8	Scan	5-28
Power switch and volume control	5-8	Display selection (type A and B audio)	5-28
Sound controls and audio settings	5-8	Folder selection	5-28
Adjustable level of each mode	5-11	How to eject a CD from the player	5-29
FM/AM radio operation	5-12	When the following messages are displayed.....	5-29
FM selection (type A and B audio)	5-12	Auxiliary input jack	5-30
AM selection (type A and B audio).....	5-12	Precautions to observe when handling a compact disc	5-31
FM/AM selection (type C audio)	5-12	USB storage device / iPod® operations (type B and C audio)	5-33
Tuning	5-12	Play file	5-33
HD Radio® Technology (Digital AM and FM Radio) (type C audio)	5-15	Connectable USB storage device	5-33
RDS text display	5-17	Connectable iPod® models.....	5-33
Station preset	5-18	Connecting USB storage device / iPod®	5-34
Satellite radio operation (if equipped)	5-19	How to play back.....	5-35
Sirius XM Satellite Radio Activation (for U.S.A. only)	5-19	To select a track from the beginning	5-35
Satellite radio reception.....	5-19	To select a chapter from the beginning when connecting iPod®	5-35
Displaying satellite radio ID of tuner	5-20	Fast-forwarding and rewinding	5-35
Band selection	5-20	Repeating	5-36
Channel and category selection.....	5-21	Random playback	5-36
Channel preset.....	5-22	SCAN (only when connecting USB storage device)	5-37
When the following messages are displayed (type C audio)	5-22		

Selecting category (only when connecting iPod®)	5-37
Display selection (type B audio)	5-39
Folder selection (only when connecting USB storage device)	5-39
Selection from list (only when connecting USB storage device) (type C audio)	5-39
Setting the playing speed (only when the audiobook is playing) (type C audio)	5-39
When the following messages are displayed	5-39
Audio control buttons	5-41
MODE button	5-41
“^” and “v” switch	5-42
Volume control switch	5-43
MUTE button (if equipped)	5-43
Bluetooth® audio (type B and C audio)	5-43
Media format	5-44
Setting Bluetooth® audio (type B audio)	5-44
Setting Bluetooth® audio (type C audio)	5-45
Bluetooth® audio operation	5-48
Hands-free system (if equipped)	5-49
Tips for the Hands-free system	5-49
Certification for the Hands-free system	5-50
Safety precautions	5-52
Using the Hands-free system	5-52
Bluetooth® setting	5-67

Antenna system

■ Printed antenna

CAUTION

Do not use sharp instruments or window cleaner containing abrasives to clean the inner surface of the window on which the antenna is printed. Doing so may damage the antenna printed on the window.

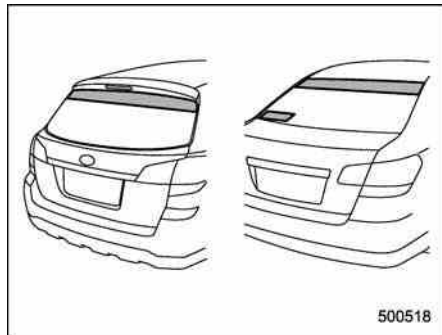

The antenna is printed on the inner surface of the rear window glass.

NOTE

Antenna performance will deteriorate significantly if you apply tinting film or

any other material over the antenna portion of the rear window glass.

■ FM reception

Although FM is normally static free, reception can be affected by the surrounding area, atmospheric conditions, station strength and transmitter distance. Buildings or other obstructions may cause momentary static, flutter or station interference. If reception continues to be unsatisfactory, switch to a stronger station.

Installation of accessories

Always consult your SUBARU dealer before installing a citizen band radio or other transmitting device in your vehicle. Such devices may cause the electronic control system to malfunction if they are incorrectly installed or if they are not suited for the vehicle.

Audio set

Your SUBARU may be equipped with one of the following audio sets. See the pages indicated in this section for operating details.

NOTE

If a cell phone is placed near the audio set, it may cause the audio set to emit noise when the phone receives calls. This noise does not indicate an audio set malfunction. Note that a cell phone should be placed as far as possible from the audio set.

■ Type A audio set (if equipped)

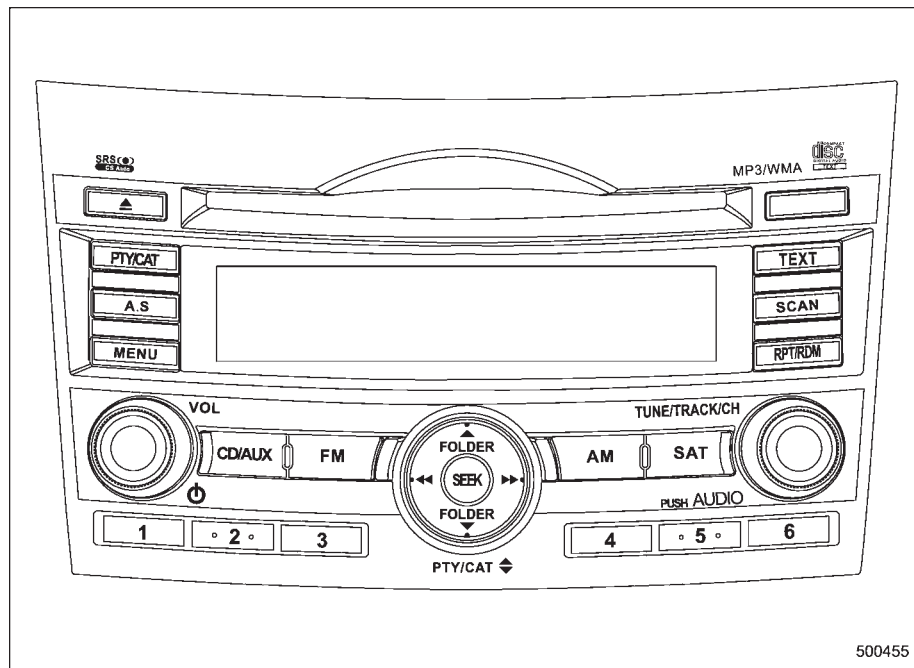

500455

The audio set will operate only when the ignition switch is in the “Acc” or “ON” position.

- Power and sound controls: refer to page 5-8
- Radio operation: refer to page 5-12
- Satellite radio operation (if equipped): refer to page 5-19
- CD (compact disc) player operation: refer to page 5-23
- Auxiliary input jack: refer to page 5-30

■ Type B audio set (if equipped)

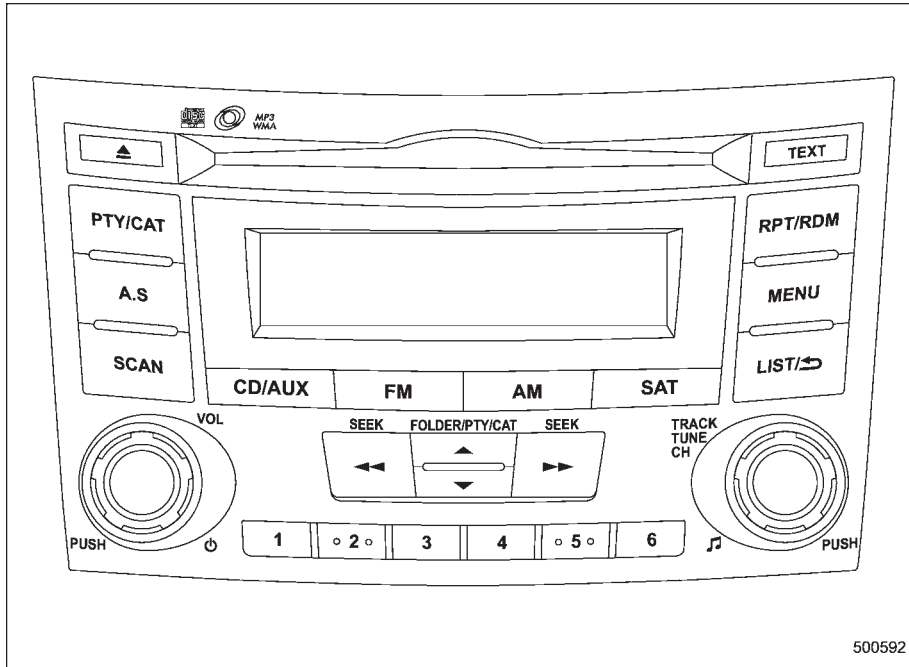

500592

The audio set will operate only when the ignition switch is in the "Acc" or "ON" position.

- Power and audio controls: refer to page 5-8
- Radio operation: refer to page 5-12
- Satellite radio operation (if equipped): refer to page 5-19
- CD (compact disc) player operation: refer to page 5-23
- Auxiliary input jack: refer to page 5-30
- USB storage device/iPod® operation: refer to page 5-33
- Bluetooth® audio: refer to page 5-43
- Hands-free system: refer to page 5-49

■ Type C audio set (if equipped)

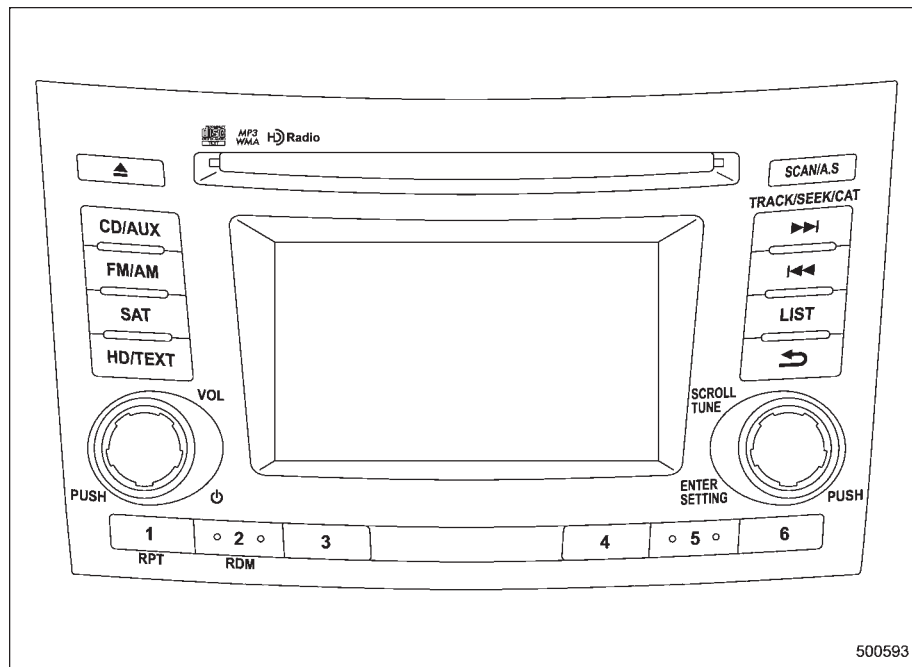

The audio set will operate only when the ignition switch is in the “Acc” or “ON” position.



- Power and audio controls: refer to page 5-8
- Radio operation: refer to page 5-12
- Satellite radio operation (if equipped): refer to page 5-19
- CD (compact disc) player operation: refer to page 5-23
- Auxiliary input jack: refer to page 5-30
- USB storage device/iPod® operation: refer to page 5-33
- Bluetooth® audio: refer to page 5-43
- Hands-free system: refer to page 5-49

NOTE

HD Radio Technology should be included as a feature in the type C audio.

Power and audio controls

■ Power switch and volume control

Type A audio	
Type B audio	
Type C audio	

The dial is used for both power (ON/OFF) and volume control. The radio is turned ON and OFF by pushing the dial, and the volume is controlled by turning the dial.

■ Sound controls and audio settings

NOTE

● **SPEED VOLUME CONTROL (SVC)** is a function that automatically adjusts the volume according to the vehicle speed. As the vehicle speed increases, the audio volume automatically increases to match the vehicle speed, in

order to create a pleasant listening environment even as the driving noise increases.

● For type A audio, SRS CS Auto is equipped. SRS CS Auto creates a 5.1ch equivalent surround field using 4 speakers that are installed in the vehicle.

● For type B audio, SRS TruBass and FOCUS are equipped.



● SRS Sound features:

(1) Sound originating from door mount speakers can be heard at ear level (built in SRS FOCUS effect) (type B audio).

(2) Ultra rich bass sound can be obtained from standard door mount speakers (built in SRS TruBass effect) (type B audio).

(3) Surround sound can be obtained from 2-channel stereo sources such as CD, MP3 and FM (built in SRS Circle Surround II effect) (type A audio).

(4) SRS CS Auto can position the center channel image in the center of the vehicle's windshield. This eliminates the need for a center speaker (built in SRS Circle Surround II phantom center and SRS FOCUS effects) (type A audio).

● CS Auto, SRS, “” and “”

symbol are trademarks of SRS Labs, Inc.

● CS Auto technology is incorporated under license from SRS Labs, inc.

● TruBass, FOCUS, SRS and “” symbol are trademarks of SRS Labs, Inc.

● TruBass and FOCUS technologies are incorporated under license from SRS Labs, Inc.

SRS 
CS Auto

SRS 
TruBass

SRS 
FOCUS

▼ **Tone and balance control (type A and B audio)**

“TUNE” dial:

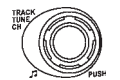
Type A audio	
Type B audio	

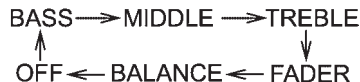

Each brief press of the “TUNE” dial changes the control modes in the following sequence.



Choose the preferred level for each mode by turning the “TUNE” dial.

The control function returns to the tune/track/channel control mode after approximately 5 seconds.

▼ **Other settings (type A and B audio)**

Type A audio	
Type B audio	

Each brief press of the “MENU” button changes the control modes in the following sequence.

Type A audio:

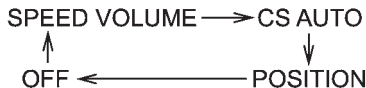

Type B audio:

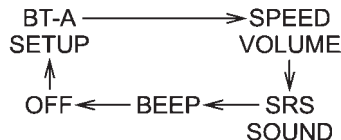

Choose the preferred settings for each mode by turning the “TUNE” dial.

The control function returns to the tune/track/channel control mode after approximately 5 seconds.

▽ **Position setting (type A audio)**

Position setting is used to adjust the sound to the best condition for the selected seating position.

ALL: The sound is adjusted to the best for all seating positions.

FR: The sound is adjusted to the best for the front passenger.

FL: The sound is adjusted to the best for the driver.

▼ **Audio settings (type C audio)**

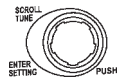
“SETTING” dial	
----------------	---

1. Press the “SETTING” dial to display the “Setting” menu.
2. Turn the “SETTING” dial clockwise or counterclockwise to select the preferred menu. The menu list is as follows.



Page	Menu
1	Screen OFF
	Bass
	Middle
	Treble
	Fader
2	Balance
	SVC
	AUX Vol.
	Brightness
	Contrast
3	HD

3. Press the “SETTING” dial to enter the selected menu.
4. Choose the preferred settings for the selected menu by turning the “SETTING” dial.
5. Press the “SETTING” dial.

NOTE

- Press the  button to return to the last mode.
- The screen will turn off if you enter the “Screen OFF” menu.
- The screen will be displayed if you perform either of the following procedures after turning the screen off in the

“Screen OFF” menu.

- Shifting the shift lever/select lever into the “R” position
 - Pressing the “SETTING” dial
 - Pressing the “FM/AM” button
 - Pressing the “CD/AUX” button
 - Pressing the “SAT” button
 - Pressing the talk switch 
 - Pressing the OFF hook switch 
- If a phone call is received on a cell phone that is connected to the Hands-free system, the audio screen will be displayed.

■ Adjustable level of each mode



Mode		Range of levels (displayed)	Initial setting	Turn counterclockwise	Turn clockwise
Volume	Volume control	0 to 40	15 (type A and B audio)/16 (type C)	For less volume	For more volume
	AUX volume control* (type A and B audio)	0 to 40	15	For less volume	For more volume
	AUX volume control (type C audio)	LOW, MID, HIGH	MID	From HIGH to MID, MID to LOW, LOW to HIGH	From LOW to MID, MID to HIGH, HIGH to LOW
Tone and balance	Bass control	-8 to +8	0	For less bass sound	For more bass sound
	Midrange control	-8 to +8	0	For less midrange sound	For more midrange sound
	Treble control	-8 to +8	0	For less treble sound	For more treble sound
	Fader	R9 to F9	0	Front attenuated	Rear attenuated
	Balance	L9 to R9	0	Right channel attenuated	Left channel attenuated
Other settings	SPEED VOLUME	OFF to 2	OFF	For less auto volume change	For more auto volume change
	CS Auto (type A audio)	OFF to 2	OFF	From 2 to 1, 1 to OFF	From OFF to 1, 1 to 2
	POSITION (type A audio)	ALL, FR, FL	ALL	From FL to FR, FR to ALL	From ALL to FR, FR to FL
	SRS Sound (type B audio)	OFF to ON	OFF	OFF	ON
	Beep (type B audio)	OFF to ON	ON	OFF	ON
	Brightness (type C audio)	-8 to +8	0	For less brightness	For more brightness
	Contrast (type C audio)	-8 to +8	0	For less contrast	For more contrast
	HD Radio (type C audio)	OFF to ON	ON	OFF	ON

*For type A audio, only when an AUX audio product is connected.

FM/AM radio operation

Press the “FM” or “AM” button (type A and B audio)/“FM/AM” button (type C audio) when the radio is off to turn on the radio.

■ FM selection (type A and B audio)

Type A audio	
Type B audio	

Press the “FM” button when the radio is on to select the preferred reception mode. Each brief press of the “FM” button changes the radio in the following sequence starting from the last FM radio band that you selected.

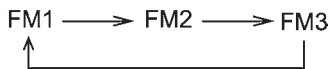

Type A audio:

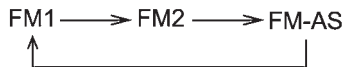

Type B audio:



■ AM selection (type A and B audio)

Type A audio	
Type B audio	

▼ Type A audio

Press the “AM” button when the radio is on to select AM reception starting from the last radio band and the last frequency interval that you selected.

▼ Type B audio

Each time the “AM” button is briefly pressed the radio changes in the following sequence starting from the last radio band that you selected.

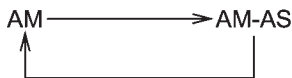

■ FM/AM selection (type C audio)

“FM/AM” button	
----------------	---

Press the “FM/AM” button when the radio

is on to select the preferred reception mode.

Each brief press of the “FM/AM” button changes the radio in the following sequence starting from the last radio band with you selected.

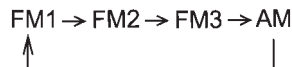

■ Tuning

▼ Manual tuning

“TUNE” dial:

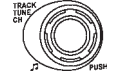
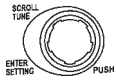
Type A audio	
Type B audio	
Type C audio	

Turn the “TUNE” dial clockwise to increase the tuning frequency and turn the “TUNE” dial counterclockwise to decrease it.

Each time the dial is turned, the frequency

interval can be changed between 10 kHz in the AM mode and 0.2 MHz in the FM mode.

▼ **Stereo indicator (type A and B audio)**

The stereo indicator “ST” will illuminate when an FM stereo broadcast is received.

▼ **Seek tuning (SEEK)**

Type A audio:

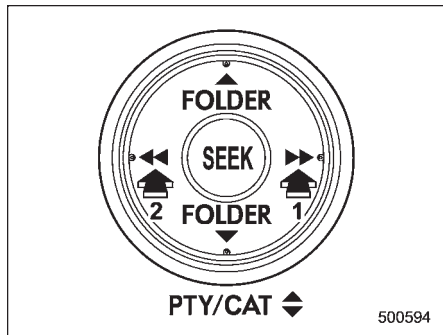

- 1) Seek up
- 2) Seek down

Type B audio:

Seek up	
Seek down	

Type C audio:

Seek up	
Seek down	

If you press the indicated button briefly, the radio will automatically search for a receivable station and stop at the first one it finds. This function may not be available when radio signals are weak. When this happens, perform manual tuning to select the preferred station.

▼ **Scan tuning (SCAN)**

Type A audio	
Type B audio	
Type C audio	

If you press the “SCAN” button, the radio will switch to the scan mode. In this mode, the radio scans through the radio band until a station is found. The radio will briefly stop at the station while displaying the frequency, after which scanning will continue until the entire band has been scanned.

Press the “SCAN” button again to cancel the SCAN mode. If you press the “SCAN” button while the radio is stopped at a station, the radio stays stopped at that station. If you press the button while the radio is scanning, the radio stops at the next receivable station (type A and C audio)/The radio stops at a frequency when the “SCAN” button is pressed (type B audio).

Automatic tuning may not function prop-

erly if the station reception is weakened by distance from the station or proximity to tall buildings and hills.

▼ **PTY (Program type) group tuning (only FM reception) (type A and B audio)**

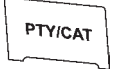
Type A audio	
Type B audio	

Press the “PTY/CAT” button to change to the PTY selection mode. At this time, the PTY group that you are currently listening to will be displayed for 10 seconds. In PTY selection mode, “PTY SEL” is displayed on the screen.

▽ **PTY (Program type) group selection**

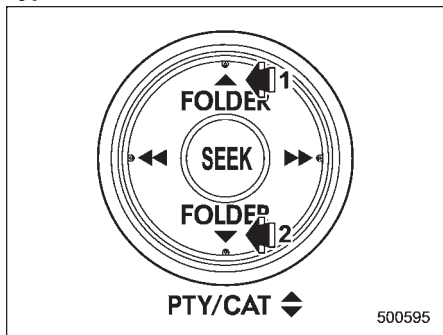

In the PTY selection mode, press the following button to change the PTY group by one step at a time.

Type A audio:



- 1) PTY group up by one step
- 2) PTY group down by one step

Type B audio:

PTY group up by one step	
PTY group down by one step	

This operation only changes the display. It does not change the station that is currently being received.

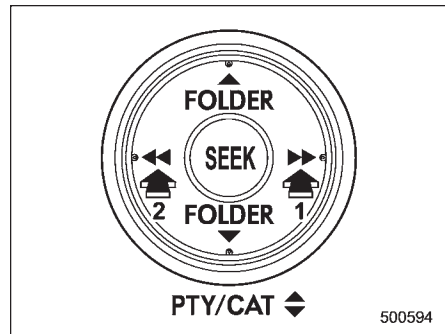

▽ **Seek in PTY (Program type) group**

Type A audio:



- 1) Seek up
- 2) Seek down

Type B audio:

Seek up	
Seek down	

In the PTY selection mode, when the desired PTY group has been selected, pressing the “SEEK” button “▶▶” or “◀◀” seeks within that PTY group. In this case, “PTY SEEK” is displayed on the screen. The control function returns to the normal

mode after approximately 10 seconds.

■ HD Radio® Technology (Digital AM and FM Radio) (type C audio)



▼ HD Radio Technology Information

▽ What is HD Radio® Technology and how does it work?

HD Radio™ Technology is the digital evolution of analog AM/FM radio. Your radio product has a special receiver which allows it to receive digital broadcasts (where available) in addition to the analog broadcasts it already receives. Digital broadcasts have better sound quality than analog broadcasts as digital broadcasts provide free, crystal clear audio with no

static or distortion. For more information, and a guide to available radio stations and programming, please visit www.hdradio.com.

▽ Using HD Radio® Technology

As a consumer works through the analog radio stations, (where applicable) the radio receiver will automatically tune from an analog signal to a digital signal within five seconds. An orange HD logo indicator will be seen on the screen when in digital.

NOTE

The HD logo will first appear in a gray color indicating the station is indeed (an analog and) a digital station. Once the digital signal is acquired, the logo will be a bright orange color.

▽ Benefits of HD Radio® Technology

1. **Information:** The song title, artist name and music genre will appear on the screen when available by the radio station.
2. **Multicast:** On the FM radio frequency most digital stations have “multiple” or supplemental programs on one FM station. When the consumer pushes the multicast button, they will move between the multiple unique program content.
3. **Clear Reception:** Unlike analog radio signals, digital signals do not pass along

static, hiss or pops.

▽ HD Radio® Technology Troubleshooting

1. **Station blending:** When acquiring a radio station, as usual, the radio will play content in analog. If the radio verifies the broadcast is an HD Radio Technology station, it will then shift or blend smoothly to a digital signal within five seconds. Depending on the station quality, the consumer may hear a slight sound change when the station switches from the analog to digital signal.

2. **Reception area:** Topography of the earth can affect radio signals. For example, when a vehicle is behind a hill or large building from the radio tower location analog reception will be poor and it is highly likely that HD Radio reception will not occur. When a consumer is on the multicast or supplemental programming (HD2/HD3/HD4) and the reception is weak or lost, this will result in a “mute” condition. On the main or HD1 program, a weak or lost digital signal will result in the playing of an analog signal until a digital signal is available.

3. **Station issues:** In order to provide the best experience, a contact form has been developed to report any radio station issues found while listening to a broad-

5-16 Audio

cast. Every radio station is independently owned and operated. These stations are responsible for ensuring all audio streams and data fields are accurate. The form can be found at www.ibequity.com/automotive/report_radio_station_experiences.

Experience	Cause	Action
Mismatch of time alignment- Customer may hear a short period of programming re-played or an echo, stutter or skip.	The radio stations analog and digital volume is not properly aligned or the station is in ballgame mode.	None, radio broadcast issue. Consumer can contact the radio station.
Sound fades, blending in and out.	Radio is shifting between analog and digital audio.	Reception issue, may clear-up as you continue to drive. HD Radio off button can force radio in an analog audio.
Audio mute condition when on an HD2/HD3 multicast channel, had been playing.	The radio does not have access to digital signals at the moment.	This is normal behavior, wait until the digital signal has returned. If out of coverage area, seek a new station.
Audio mute delay when selecting HD2/HD3 multicast channel preset.	The digital multicast content is not available until HD Radio broadcast can be decoded and make the audio available. This takes up to seven seconds.	This is normal behavior, wait for the audio availability.
Text information does not match the present song audio.	Data service issue by the radio broadcaster.	Broadcaster should be notified. Complete the form: www.ibequity.com/automotive/report_radio_station_experiences .
No text information shown for the present selected frequency.	Data service issue by the radio broadcaster.	Broadcaster should be notified. Complete the form: www.ibequity.com/automotive/report_radio_station_experiences .

▼ Other information

HD Radio Technology manufactured under license from iBiquity Digital Corporation. U.S. and Foreign Patents. HD Radio® and the HD, HD Radio, and “Arc” logos are proprietary trademarks of iBiquity Digital Corp.

▼ HD Radio selection

Press the  button while receiving FM radio (except analog broadcast). The next channel of the station that is being received will play.

▼ Mode selection

Turn the “SETTING” dial and select the HD Radio ON mode (hybrid mode) or OFF mode (analog mode). For details, refer to “Audio settings (type C audio)” 5-9.

NOTE



Depending on the broadcasting area, the digital signal may not be received in an area where the analog signal can be properly received, or the system frequently switches the channels between the digital and analog signals. However, this does not indicate a malfunction. If this frequent switching between digital and analog causes annoyance, set the radio to the analog mode (HD Radio off mode) that provides the same radio broadcasting quality as a con-

ventional radio.

▼ HD Radio indicator

The  indicator illuminates while the digital broadcast is received during the HD Radio ON mode.

■ RBDS text display

Type A audio	
Type B audio	
Type C audio	

▼ Type A and B audio

If the PS (Program Service Name) and/or RT (Radio Text) are available, pressing the “TEXT” button changes the display among PS, RT and frequency. The initial setting is “PS”.

NOTE

- The maximum number of characters that can be displayed for PS is 8.
- The maximum number of characters that can be displayed for RT is 64.
- If RT is 16 characters or longer, press and hold the “TEXT” button in

order to change the page.

▼ Type C audio

Press and hold the “HD/TEXT” button to show the next page when the text is not fully displayed while the PSD (Program Service Data) or RT (Radio Text) service is received.

NOTE

- When the HD Radio function is turned on, PSD provides additional information about the broadcast. Text data such as “Title” and “Artist” is displayed on the screen. To display text data other than that which is currently being displayed, turn the “SETTING” dial.
- When the HD Radio function is turned off (HD Radio off mode), the radio text is displayed on the screen while receiving the broadcasting station within RBDS (Radio Broadcast Data System).
- The maximum number of characters that can be displayed is 128.

■ Station preset

▼ How to preset stations

1. Select the preferred reception mode.
2. Select the preferred station.
3. Press and hold one of the preset buttons (from to) to store the frequency. If the button is pressed briefly, the preceding selection will remain in the memory.

NOTE

- Up to six stations for each reception mode may be preset.
- If the connection between the radio and battery is broken for any reason such as vehicle maintenance or radio removal, all stations stored in the preset buttons are cleared. If this occurs, it is necessary to reset the preset buttons.
- If a cell phone is placed near the radio, it may cause the radio to emit noise when a phone call is received. This noise does not indicate a radio malfunction.
- For type C audio, if you press and hold a preset button while receiving a broadcasting station with SPS (Supplemental Program Service), the station will be stored in the memory for that

preset button.

▼ Selecting preset stations



1. Select the preferred reception mode.
2. Press the preferred preset button (from to) briefly.

NOTE

For type C audio, if the preset button which stores a broadcasting station with SPS (Supplemental Program Service) while the HD Radio OFF mode is selected, “No digital data available” will be displayed and the volume will be reduced to zero.

▼ Auto-store

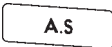
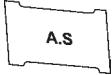
Auto-store button:

Type A audio	
Type B audio	
Type C audio	

Using the Auto-store function, you can automatically store 6 stations on the

current waveband by pressing and holding the Auto-store button. Use Auto-store to quickly find the strongest stations, for example when traveling through different reception areas.

NOTE

- When you use Auto-store, the new stations replace any stations previously stored.
- Interrupting Auto-store: If you accidentally press the Auto-store button, you can cancel the Auto-store function before it has been completed as follows.
 - Switch to the other source mode.
 - Switch to the other band.
 - Press the Auto-store button.
 - Press the “SCAN” button (type A and B audio).
 - Press the “SEEK” button.
 - Press any of the preset buttons.
 - Turn the “TUNE” dial.
 - Turn off the audio system.
 - Turn off the ignition switch.
- When you use the Auto-store function while selecting the FM mode, even if you have selected the FM1 or FM2 station, the new stations are stored in the FM3 (type A and C audio)/FM-AS (type B audio) station memory.
- For type B audio, when you use the

Auto-store function while selecting the AM mode, even if you have selected the “AM” station, the new stations are stored in the AM-AS station memory.

- If it is only possible to receive less than 6 stations, the available stations are stored from preset 1 in order by frequency and the unused preset buttons are not registered to a station.
- For type A and C audio, the previously registered station memories of the unused preset buttons are cleared.
- For type B audio, the previously registered station memories of the unused preset buttons are not cleared.
- If no stations can be received, the previously stored stations are not replaced.
- After pressing the Auto-store button, if more than 1 station is stored, the radio receives the station stored in preset 1.
- After pressing the Auto-store button, if no stations are stored, the radio receives the band and station that the radio received before pressing the button.

Satellite radio operation (if equipped)

To receive satellite radio, it is necessary to install the SUBARU genuine satellite receiver for some models, and to enter into a contract with a satellite radio network service such as “Sirius XM™ satellite radio” (for U.S.A. only). For details, please contact your SUBARU dealer.

■ Sirius XM™ Satellite Radio Activation (for U.S.A. only)

Models with Sirius XM™ are eligible for a 3-month complimentary subscription to the Sirius XM™ Satellite Radio service.

▼ Activation process

If you would like to activate your Satellite Radio online, please visit <http://www.siriusxm.com/activationhelp> and follow the step-by-step instructions for easy activation.

■ Satellite radio reception

Satellite radio signals are best received in areas with a clear view of the open sky. In areas where there are tall buildings, trees, tunnels or other structures that may obstruct the signal of the satellites, there may be signal interruptions. Other circum-

stances that may result in signal loss include driving near a wall, steep cliff, hill or driving on the lower level of a multi-tiered road or inside of a parking garage.

To help reduce this condition, satellite radio providers have installed ground-based repeaters in heavily populated areas. However, you may still experience reception problems in some areas.

▼ Sirius XM™ satellite radio reception tips (for U.S.A. only — if equipped)

The Sirius XM™ satellite radio receiver that is fitted to your vehicle receives the necessary signals from two specially designated satellites that are in a geostationary orbit over the equator. One satellite covers the east coast and the other covers the west coast. Both of them direct their signals north. These signals are then relayed throughout the radio reception area by a network of ground repeater stations. The satellite radio signals are transmitted as “line of sight” signals. The line of sight signals can be blocked by objects such as buildings, but the network of repeater stations allows signal coverage within urban areas such as cities.

You may experience problems in receiving Sirius XM™ satellite radio signals in the following situations.

- If you are driving northward in a coastal area

Because the satellite radio antenna is located on the windshield, the signal comes from the south and may not be able to reach the antenna in some circumstances when you are driving north.

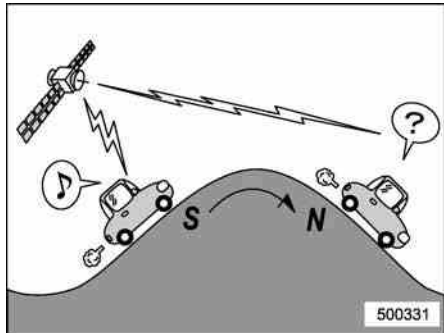

- If you are driving in a tunnel or a covered parking area
- If you are driving beneath the top level of a multi-level freeway
- If you drive under a bridge
- If you are driving next to a tall vehicle (such as a truck or a bus) that blocks the signal
- If you are driving in a valley where the surrounding hills or peaks block the signal from the south

- If you are driving on a mountain road where the southern direction is blocked by mountains

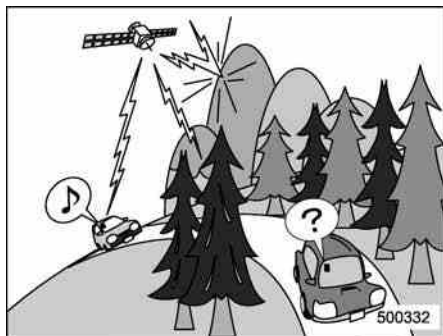

- If you are driving in an area with tall trees that block the signal (10 m or more), for example on a road that goes through a dense forest
- The signal can become weak in some areas that are not covered by the repeater station network.

Please note that these may be other unforeseen circumstances when there are problems with the reception of Sirius XM™ satellite radio signals.

■ Displaying satellite radio ID of tuner

When you activate satellite radio, you should have your satellite radio tuner ID ready because each tuner is identified by its unique satellite radio tuner ID.

The satellite radio ID will be needed when you activate satellite radio and receive satellite radio customer support.

For details, contact your SUBARU dealer.

■ Band selection

Type A audio	SAT
Type B audio	SAT
Type C audio	SAT

Press the “SAT” button when the radio is off to turn on the radio.

Press the “SAT” button when the radio is on to select SAT1, SAT2 or SAT3 reception.

■ **Channel and category selection**

▼ **Channel selection by operating the dial**

“TUNE” dial:

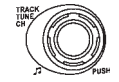
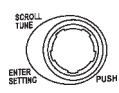
Type A audio	
Type B audio	
Type C audio	

Turn the “TUNE” dial clockwise to select the next channel and turn the “TUNE” dial counterclockwise to select the previous channel.

▼ **Channel selection by pressing the button (type A audio)**

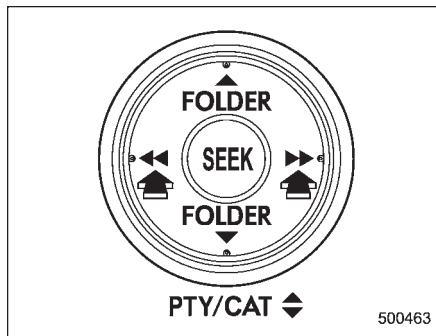

When in the SAT mode, briefly press the “SEEK” button “◀◀” or “▶▶” to select the channel.

▼ **Skip channel selection (type A and B audio)**

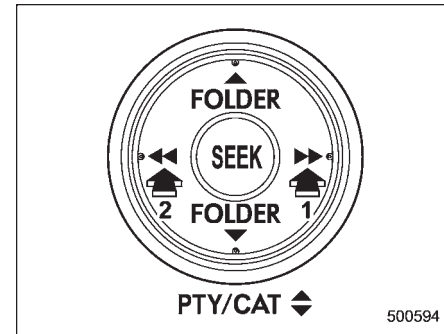

When in the SAT mode, press and hold the following buttons to change to the channel selection mode.

Type A audio:





- 1) Change the channel up by 10 channels
- 2) Change the channel down by 10 channels

Type B audio:

Change the channel up by 10 channels	
Change the channel down by 10 channels	

▼ **Category selection (type C audio)**

Change the category up by one step	
Change the category down by one step	

To activate the category search mode, press the “◀◀” or “▶▶” button. When in the category search mode, press the “◀◀” or “▶▶” button to change the category up or down.

When a category is selected, turning the “TUNE” dial selects channels only within the selected category.

The control function returns to the normal mode after approximately 6 seconds.

▼ **Channel scan (type C audio)**

“SCAN/A.S” button	
-------------------	---

Press the “SCAN/A.S” button to change the radio to the SCAN mode. In this mode, under the selected category, the radio scans through the channel until a station is found. The radio will stop at the station for 5 seconds while displaying the channel number, after which scanning will continue until the entire channel has been scanned.

Press the “SCAN/A.S” button again to cancel the SCAN mode and to stop on any displayed channel.

■ **Channel preset**

▼ **How to preset channels**

1. Press the “SAT” button to select SAT1, SAT2 and SAT3 reception.
2. Select the desired channel.
3. Press and hold one of the preset buttons (from to) to store the channel. If the button is pressed briefly, the preceding selection will remain in the memory.

NOTE

- Up to six SAT1, SAT2 and SAT3 channels each may be preset.
- If the connection between the radio and battery is broken for any reason such as vehicle maintenance or radio removal, all channels stored in the preset buttons are cleared. If this occurs, it is necessary to reset the preset channels.

▼ **Selecting preset channels**

1. Press the “SAT” button to select SAT1, SAT2 or SAT3 reception.
2. Press the preferred preset button (from to) briefly.

■ **When the following messages are displayed (type C audio)**

If one of the following messages is displayed when receiving XM signals, determine the cause based on the following information. If you cannot clear these messages, contact your SUBARU dealer.

Message	Status
CHECK ANTENNA	The antenna cannot be detected because it has become disconnected, etc.
NO SIGNAL	There is no reception because the system cannot obtain signals that are strong enough.
LOADING	The system temporarily cannot be used because it is currently receiving signals or is decoding.
CHANNEL OFF AIR	The channel that has been selected is currently off air.
CHAN UNAVAILABLE	The service cannot currently be used.
CH UNAUTHORIZED	A channel for which you do not have a subscription has been selected.

CD player operation

CAUTION

This is a class I laser product. Use of controls or adjustments or performance of procedures other than those specified herein may result in hazardous radiation exposure. Do not open covers and do not attempt to repair this unit by yourself. Refer servicing to qualified personnel.

NOTE

- Make sure to always insert a disc with the label side up. If a disc is inserted with the label side down, the player displays “CHECK DISC”. Refer to “When the following messages are displayed” 5-29.
- If a disc is inserted during a radio broadcast, the disc will interrupt the broadcast.
- After the last track finishes, the disc will automatically return to track 1 (the first track on the disc) and will automatically play back.
- The player is designed to be able to play music CD-Rs and music CD-RWs, but it may not be able to play certain ones.

- Mini CDs (i.e., 8 cm/3 inch CDs) are not supported, and if inserted, they will be immediately ejected.
- Audio data recorded in the MP3/WMA/AAC formats may not be played depending on the data recording condition.
- CDs that can be played back are accompanied by the following restrictions.
 - Maximum number of folders: 255
 - Maximum number of files in a folder: 255
 - Maximum number of files on a CD: 999 (type A audio)/510 (type B audio)/512 (type C audio)
 - Maximum number of layers: 8 (including the root folder)

■ Play file

NOTE

- Copyright protected MP3/WMA/AAC files will not be played by the system. The player will automatically skip to the next file (track).
- WMA9 Lossless, WMA9 Professional and WMA9 voice cannot be played.

MP3:

- Based on MPEG 1, 2 and 2.5 Layer 3 (type A and B audio)
- Based on MPEG 1, 2 and 2.5 Layer 2 and 3 (type C audio)
- Sampling rate (kHz): 48, 44.1, 32, 24, 22.05, 16, 12, 11.025, 8
- Bit rate (kbps): 8 to 320 (type A and B audio)
- Bit rate (kbps): 32 to 320 (type C audio)
- Supports variable bit rates

WMA (type B audio):

- Based on Windows Media Audio 9
- Sampling rate (kHz): 48, 44.1, 32
- Bit rate (kbps): 32 to 192

WMA (type C audio):

- Based on Windows Media Audio 7, 8 and 9
- Sampling rate (kHz): 48, 44.1, 32
- Bit rate (kbps): 32 to 192

AAC (type B audio):

- Based on MPEG4 AAC
- Sampling rate (kHz): 48, 44.1, 32, 24, 22.05, 16, 12, 11.025, 8
- Bit rate (kbps): 24 to 320
- Number of channels: 1 to 2ch

AAC (type C audio):

- Based on MPEG2 AAC and MPEG4 AAC
- Sampling rate (kHz): 48, 44.1, 32, 24, 22.05, 16, 12, 11.025, 8
- Bit rate (kbps): 24 to 320
- Number of channels: 1 to 2ch

How to insert a CD

While the ignition switch is in the “Acc” or “ON” position, hold a disc with a finger in the center hole while gripping the edge of the disc, then insert it in to the slot (with the label side up) and the player will automatically pull the disc into position.

NOTE

DO NOT INSERT TWO DISCS INTO THE DISC INSERTION SLOT AT A TIME.

How to play back a CD

When there is no CD inserted

Insert a CD by referring to “How to insert a CD” 5-24.

When a CD is loaded, the player will start playback of the CD, beginning with the first track.

When CD is in the player (type A)

When the  button is pressed, the player will start playback.

When CD is in the player (type B and C)

Type B audio	
Type C audio	

Each brief press of the “CD/AUX” button changes the modes in the following sequence.

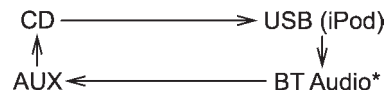

*: For type B audio, “BT-A” is displayed.

When the CD mode is selected, the player will start playback.

To select a track from the beginning

NOTE

With an MP3, WMA or AAC:

- Skipping past the last track/file will take you back to the first track/file in the folder.

- Skipping past the first track/file will take you to the last track/file in the folder.

▼ By using the dial (type A and B audio)

“TRACK” dial:

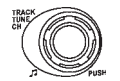

Type A audio	
Type B audio	

Turn the “TRACK” dial clockwise to skip to the beginning of the next track/file. Each time the dial is turned, the indicated track/file number will increase.



Turn the “TRACK” dial counterclockwise to skip to the beginning of the current track/file. Each time the dial is turned, the indicated track/file number will decrease.

▼ By using the button (type B and C audio)

Type B audio:

Forward direction	
Backward direction	

Type C audio:

Forward direction	
Backward direction	

Press the “▶▶” button briefly to skip to the beginning of the next track/file. Each time the button is briefly pressed, the indicated track/file number will increase.

Press the “◀◀” button briefly to skip to the beginning of the current track/file. Each time the button is briefly pressed, the indicated track/file number will decrease.

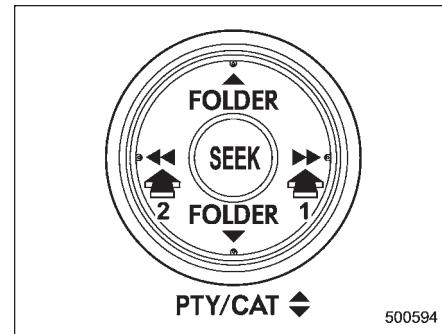

■ Fast-forwarding and rewinding

Type A audio:





- 1) Fast-forwarding
- 2) Rewinding

Type B audio:

Fast-forwarding	
Rewinding	

Type C audio:

Fast-forwarding	
Rewinding	

Press and hold the “▶▶” button to fast-forward the track/file. Release the button to stop fast-forwarding.

Press and hold the “◀◀” button to rewind the track/file. Release the button to stop rewinding.



NOTE

- If you fast-forward to the end of the last track/file, fast-forwarding will stop and the player will start playback beginning with the first track/file. For an MP3, WMA or AAC folder, the player will start playback beginning with the first track/file of the next folder.

- If you rewind to the beginning of the first track/file, rewinding will stop and the player will start playback. For an MP3, WMA or AAC folder, the player will start playback beginning with the first track/file of the current folder.

Repeating

Repeat button:

Type A audio	
Type B audio	
Type C audio	

To repeat a track/file, briefly press the repeat button while the track/file is playing. Each time you briefly press the repeat button, the mode changes in the following sequences.

Type A and B audio:

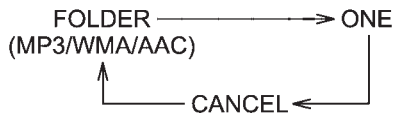

Type C audio:

**NOTE**

- The “TRACK RPT” (type A and B audio)/“ONE” (type C audio) indication refers to the repeat playback of a single track. It repeats the track that is playing.

- The “FOLDER RPT” (type A and B audio)/“FOLDER” (type C audio) indication refers to the repeat playback of a folder. It repeats the all of the tracks in the folder. It is possible to select the function when the MP3/WMA/AAC format track is playing.

To cancel the track/file repeat-play mode, briefly press the repeat button and select CANCEL. The “RPT” indication will turn off, and the normal playback mode will be resumed.



NOTE

The repeat-play mode will be cancelled if you perform any of the following steps:

- Press the “▲” button.
- Press the “SCAN” button.
- Turn the “TUNE” dial during repeat playback of a single track (type C audio).

■ Random playback

Random button:

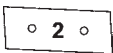
Type A audio*1	
Type B audio*1	
Type C audio*2	

*1: Press and hold the button.

*2: Press the button briefly.

To play back a track/file(s) at random, press the random button.

Each time you press the button, the mode changes in the following sequences.

Type A audio:

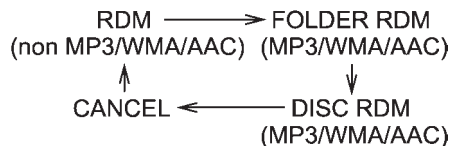

Type B audio:



Type C audio:



NOTE

- The “RDM” indication refers to the random playback of the tracks. It randomly repeats the tracks on the CD. It is possible to select the function when formats other than the MP3/WMA/AAC format CD is playing.
- The “FOLDER RDM” (type A and B audio)/“FOLDER” (type C audio) indication refers to the random playback in the folder. It randomly repeats the tracks in the folder. It is possible to select the function when an MP3/WMA/AAC format track is playing.
- The “DISC RDM” (type A audio)/“ALL RDM” (type B audio)/“ALL” (type C audio) indication refers to the random playback of a disc. It randomly repeats the tracks on the CD. It is possible to select the function when

an MP3/WMA/AAC format track is playing.

To cancel the random playback mode, press the random button and select CANCEL.

The “RDM” indication will turn off, and the normal playback mode will be resumed.

NOTE

Random playback will be cancelled if you perform any of the following steps:

- Press the “▲” button.
- Press the “SCAN” button.
- Press the “▼” or “▲” side of the “FOLDER” button when an MP3/WMA/AAC format track is playing (type A and B audio).
- Turn the “TUNE” dial during random playback of the disc (type C audio).

▼ **Type A and B audio**

Press the following buttons briefly.

Type A audio:

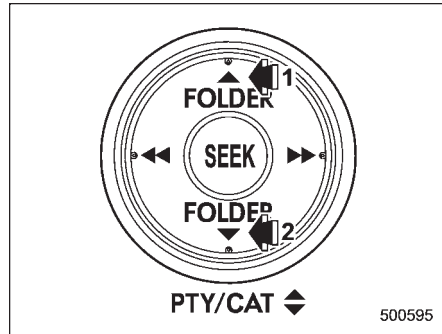

- 1) To select the next folder
- 2) To go back to the previous folder

Type B audio:

To select the next folder	
To go back to the previous folder	

▼ **Type C audio**



Turn the “TUNE” dial clockwise to select the next folder. Turn the dial counter-clockwise to go back to the previous folder.

■ **How to eject a CD from the player**

When a disc is being played back or when a disc is in the player, press the eject button . The disc will be ejected.

NOTE

- **Avoid driving the vehicle with a CD sticking out. The CD may fall out due to vibration.**
- **If you do not remove the ejected disc within approximately 15 seconds (type A and B audio)/20 seconds (type C audio), a disc protection function will operate, automatically reloading the disc. In this case, the disc is not played.**

■ **When the following messages are displayed**

If one of the following messages is displayed while operating the CD player, determine the cause based on the following information. If you cannot clear those messages, please contact your SUBARU dealer.

▼ **When “PUSH EJECT” is displayed**

Press the button to eject the disc. Check the disc for damage or deformation, and also check that the correct disc is inserted. Do not try to eject the disc forcibly. Mini CDs (i.e., 8 cm/3 inch CDs) are not supported, and if inserted, they will be immediately ejected. If the disc cannot be ejected or this message remains displayed, please contact your SUBARU dealer.

▼ **When “CHECK DISC” is displayed**

Press the button to eject the discs. Check that the disc is not damaged or scratched, and also check that the disc is inserted correctly. This message may appear when using some CD-RW discs. Check that the disc type (i.e., 8 cm/3 inch CDs are not supported) and data format are correct. This player can only play CD-DA, MP3, WMA and AAC data formats. If the disc cannot be ejected or this message remains displayed, please contact

your SUBARU dealer.

▼ **When “No audio file” is displayed (type C audio)**

Press the  button to eject the disc. This message appears when a CD has been loaded that does not contain any playable files. Insert a CD that contains playable files.

Auxiliary input jack

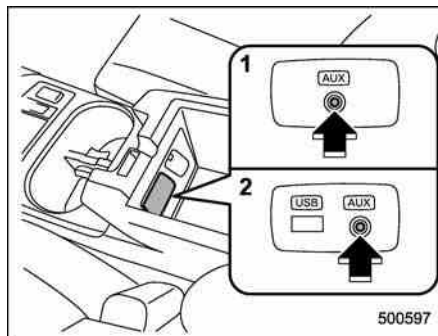



- 1) Models without Hands-free system
- 2) Models with Hands-free system

You can connect an external audio device to the vehicle's audio system and play back audio via the vehicle's speakers.

An auxiliary (AUX) input jack is equipped in the center console. A stereo mini pin plug (3.5 ϕ) can be inserted in this jack. The connection cable is available at electrical appliance or similar stores.

To use the AUX input jack:

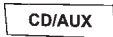
1. Connect a portable audio player to the AUX input jack.

Type A audio	
Type B audio	
Type C audio	

2. Press the AUX input selection button “CD/AUX” on the audio control panel to select the AUX mode. For type B and C audio, refer to “When CD is in the player (type B and C)”  5-24.

3. Play back the portable audio player. Refer to the instruction manual of the portable audio player.

NOTE

- **The output sound of the portable audio player is not loud, and the sound via the vehicle's speakers that are connected to the vehicle audio set is very low. If you turn up the volume of the audio set, the volume becomes louder. However, when you change the player to the other portable audio player, the sound may become a lot louder. Turn down the volume when you change between them.**
- **In some cases, when the sound**

volume of the portable audio player is low, the sound quality may become impaired when you turn up the volume of the vehicle audio system. In this case, adjust the sound volume of the portable audio player.

- In some cases, noise occurs because of a bad connection between the portable player and the audio system. Try cleaning the stereo jack and audio plug.
- If noise is not reduced, check for disconnection of the cord or a malfunction of the portable player.

Precautions to observe when handling a compact disc

Use only compact discs (CDs, CD-Rs and CD-RWs) that have the mark shown in the following illustration. Also, some compact discs cannot be played.



COMPACT
disc
DIGITAL AUDIO



COMPACT
disc
Recordable



COMPACT
disc
ReWritable

500090

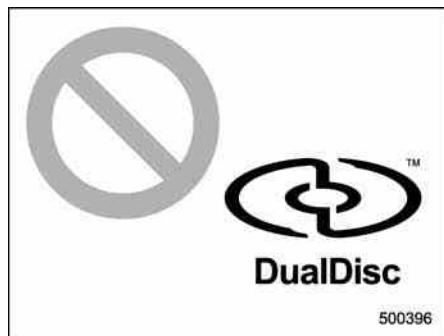

- You cannot use a DualDisc in the CD player. If you insert a DualDisc into the player, the disc may not come out again, possibly causing the player to malfunction.
- In cold and/or rainy weather, dew can form inside the CD player, preventing normal operation. If this happens, eject the CD and wait for the player to dry out.
- Skipping may occur when the CD player is subjected to severe vibration (for example, when the vehicle is driven on a rough surface).
- To remove a disc from the case, press the center of the case and hold both edges of the disc. If the disc surface is touched directly, contamination could cause poor tone quality. Do not touch the disc surface.
- Use a clean disc whenever possible. If

there are deposits, wipe the disc surface from the center outward with a dry, soft cloth. Be sure not to use a rough cloth, thinner, benzine, alcohol, etc.

- Do not use any disc that is scratched, deformed, or cracked. Also, do not use any disc that has a non-standard shape (for example, a heart shape). Malfunctions or problems might result.
- A disc is vulnerable to heat. Never keep it either in places exposed to direct sunlight, near heaters or in vehicles parked in the sun or on hot days.

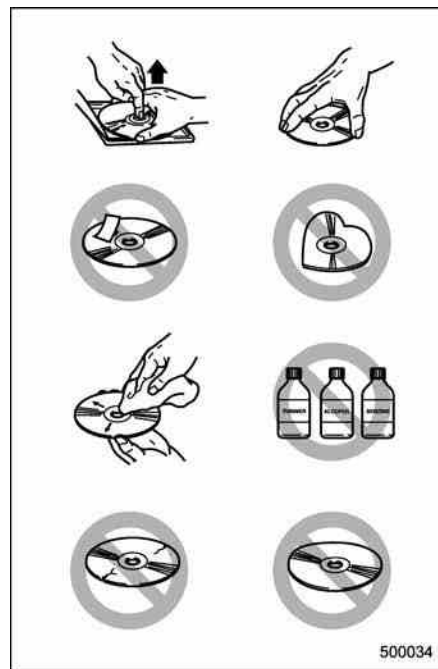

USB storage device / iPod® operations (type B and C audio)

■ Play file

Refer to "Play file" 5-23.

■ Connectable USB storage device

Mass storage class USB memory can be connected. USB storage devices that can be played back are accompanied by the following restrictions.

- Maximum directory layers: 8 layers (including the ROOT)
- Maximum number of files in a folder: 255
- Maximum number of folders: 512 (type B audio)/255 (type C audio) (including the ROOT)
- Maximum number of files on the device: 130,560 (type B audio)/2,500 (type C audio)

NOTE

- HUB class USB memory cannot be played.
- ATAPI subclass USB cannot be played.
- High Speed USB 2.0 cannot be played.

- A USB memory that is powered by a source other than the USB power supply (for example, an AC power adapter, etc.) cannot be operated.
- A USB memory that is connected to the memory card reader or multi card reader cannot be operated.
- If the USB memory consists of two drives or more, the system will recognize only one of the drives after connecting the USB memory.
- The contents stored on the USB memory may not be played in the same order as they appear on a personal computer.
- A personal computer cannot be used even if it is connected to the system using a USB cable.
- If the USB memory has a security function, the contents stored on the USB memory cannot be played by the system.
- A USB memory and an iPod® cannot be connected to the system at the same time.

■ Connectable iPod® models

Type B audio:

	Model	Firmware version
iPod®	5G	1.3
	5.5G	1.3
	classic 1G	2.0.4
	classic 2G	
	nano 2G	1.1.3
	nano 3G	1.1.3
	nano 4G	1.0.4
	nano 5G	1.0.2
	touch 1G	3.1.2
touch 2G	3.1.2	
iPhone®	1G	3.1.2
	3G	3.1.2
	3G S	3.1.2

Type C audio:

	Model	Firmware version
iPod®	5G	1.2.1~1.3
	classic	1.0.0~1.1.2
	nano	1.3.1
	nano 2G	1.1.3
	nano 3G	1.0.0~1.1.3
	nano 4G	1.0.0~1.0.3
	touch	1.1~2.2.1
iPhone®	1G	3.1.3
	3G	4.2.1
	3G S	4.2.1
	4	4.2.1

**CAUTION**

Do not connect an iPod® other than the previously stated models. Doing so may result in a malfunction or, depending on conditions, cause a fire.

NOTE

- iPod® is a registered trademark of Apple Inc.
- You are only permitted to personally copy and play copyright-free material

or material that is legally permitted to be copied and played by using an iPod® and iTunes. Copyright infringement is prohibited by law.

- To check the firmware version of an iPod®, connect it to a computer and check the device manager. For further information, see the User's Guide that comes with the iPod®.
- To update the firmware version of an iPod®, visit the Apple Inc. website.
- Depending on the model and firmware version of an iPod®, it may not work properly or not operate at all.

■ Connecting USB storage device / iPod®

**WARNING**

Do not operate an iPod® while driving. Doing so may distract your attention from driving and could lead to an accident.

**CAUTION**

- If the data stored on an iPod® is deleted while it is connected to the in-vehicle system, the data cannot be recovered.

- Do not store an iPod® in the vehicle. If an iPod® is left in the vehicle for a long period of time, it may be deformed, discolored or damaged by high temperature.

NOTE

- Even if a USB storage device or iPod® is connected, it cannot be played unless the USB/iPod® mode is selected.
- Movies stored on a USB storage device or an iPod® cannot be played while the storage device or iPod® is connected to the system.
- While an iPod® is connected, the iPod® cannot be operated using the click wheel on the iPod® (except some models).
- When using an iPod® by connecting it to in-vehicle equipment, the order of the list items displayed on the in-vehicle equipment may be different from that on the iPod®. However, this does not indicate a malfunction.
- An iPod® battery that is connected to in-vehicle equipment will be charged when the ignition switch is in the "ON" or "Acc" position. However, activation of the iPod® may be delayed if the battery charge of the iPod® is low.
- If an iPod® does not activate after

operation, disconnect the connection cable from the iPod® and reset it. For the resetting procedure, see the User's Guide of the iPod®.

- If an iPod® and the connection cable are connected improperly, the iPod® cannot be powered on or will not be recognized by in-vehicle equipment. In this case, disconnect the connection cable from the iPod®, and then connect it again.

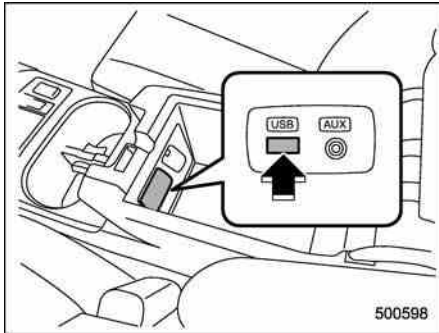

The USB connector is located in the center console. Use the connector to connect a USB storage device/iPod®.

■ How to play back

NOTE

- Depending on the number of files stored on the iPod® and the firmware version, the iPod® may not activate smoothly after operation or not work properly.
- Do not disconnect the connector from the iPod® during iPod® operation.

▼ Type B audio

1. Connect a USB storage device/iPod®.
2. Press the  button. Each time you briefly press the button, the mode changes as follows.

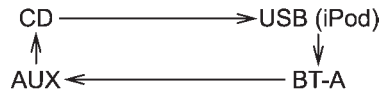

When the USB/iPod® mode is selected, the player will start playback of the USB storage device/iPod®.

▼ Type C audio

▽ When a USB storage device/iPod® is not connected

Connect a USB storage device/iPod®. Then the player will start playback of the USB storage device/iPod®.

▽ When a USB storage device/iPod® is already connected

Press the  button. Each time you briefly press the button, the mode changes as follows.

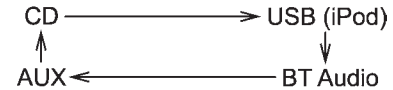

When the USB/iPod® mode is selected, the player will start playback of the USB storage device/iPod®.

■ To select a track from the beginning

Select a track in the same way as for a CD. For details, refer to "To select a track from the beginning" 5-24.

■ To select a chapter from the beginning when connecting iPod®

When playing podcasts or audiobooks, select a chapter in the same way as for a CD. For details, refer to "To select a track from the beginning" 5-24.

■ Fast-forwarding and rewinding

Fast-forwarding and rewinding are operated in the same way as for a CD. For

details, refer to “Fast-forwarding and rewinding” 5-25.

NOTE

When connecting iPod®:

- When the end of a track is reached while fast-forwarding, fast-forwarding ends and play begins from the beginning of the next track.
- When the beginning of a track is reached while rewinding, rewinding ends and play begins from the beginning of the track.



Repeating

▼ When connecting USB storage device

Repeating is operated in the same way as for a CD. For details, refer to “Repeating” 5-26.

▼ When connecting iPod®

Repeat button:

Type B audio	
Type C audio	

Each time you briefly press the repeat button, the mode changes in the following sequence.

Type B audio:



Type C audio:

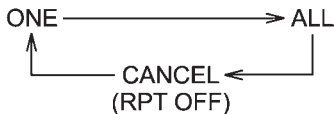



NOTE

- The “ALL RPT” (type B audio)/“ALL” (type C audio) indication refers to the repeat playback of all tracks in the entire iPod® (type B audio)/playing list (type C audio).
- The “SONG RPT” (type B audio)/“ONE” (type C audio) indication refers to the repeat playback of a single track. It repeats the track that is playing.
- When an audiobook is playing, the mode does not change even if you press the repeat button. For type C audio, refer to “Setting the playing speed (only when the audiobook is playing) (type C audio)” 5-39.

Random playback

Random button:

Type B audio*1	
Type C audio*2	

*1: Press and hold the button.
*2: Press the button briefly.

To playback a track at random, press the random button while the track is playing.

Each time you press the button, the mode changes in the following sequences.

When connecting USB storage device (type B audio):

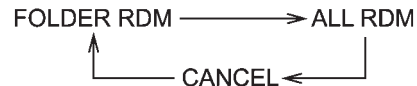

When connecting USB storage device (type C audio):



When connecting iPod® (type B audio):



When connecting iPod® (type C audio):



NOTE

- The “FOLDER RDM” (type B audio)/ “Folder” (type C audio) indication refers to the random playback in the folders. It randomly repeats all of the tracks in the folder.
- The “ALL RDM” (type B audio)/“All” (type C audio) indication refers to the random playback on the entire USB storage device. It randomly repeats all of the tracks on the USB storage device.
- The “ALBUM RDM” (type B audio)/ “Album” (type C audio) indication refers to the shuffle playback of the album. It sequentially plays back all of the tracks on the album.
- The “SONG RDM” (type B audio)/ “Track” (type C audio) indication refers to the shuffle playback on the entire iPod®. It randomly repeats all of the

tracks on the iPod®.

- When an iPod® is connected, the files are played back at random by the shuffle function of the iPod®. Therefore, iPod® operation may be different depending on the model of the connected iPod®. Visit the Apple Inc. website for details.
- When an audiobook or a podcast is playing, the mode does not change even if you press the random button.

To cancel the random playback mode, press the random button and select CANCEL. The “RDM” indication will turn off, and the normal playback mode will resume.

■ SCAN (only when connecting USB storage device)

Scan is operated in the same way as for a CD. For details, refer to “Scan” 5-28.

NOTE

When an iPod® is connected, you cannot select the SCAN mode.

■ Selecting category (only when connecting iPod®)

▼ Type B audio

“LIST” button	
“TUNE” dial	

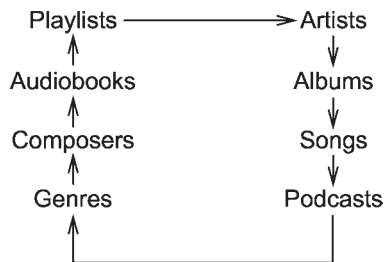

When the “LIST” button is pressed briefly, the iPod® menu is displayed.

Each time you turn the “TUNE” dial clockwise, the displayed category changes in the following sequence. Each time you turn the dial counterclockwise, the displayed category changes in the opposite sequence.



To select the category, press the dial. To close the iPod® menu, press and hold the “LIST” button. To return to the previous screen, briefly press the “LIST” button.

▼ Type C audio

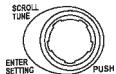
“LIST” button	
“BACK” button	
“TUNE” dial	

When the “LIST” button or “BACK” button is pressed briefly, the iPod® menu is displayed as follows.

	1st layer	2nd layer	3rd layer	4th layer	5th layer
Now playing	—	—	—	—	—
Playlists	—	Playlists List	Songs List	—	—
Artists	—	Artists List	Albums List	Songs List	—
Albums	—	Albums List	Songs List	—	—
Songs	—	Songs List	—	—	—
Podcasts	—	Podcasts List	Songs List	—	—
Genres	—	Genres List	Artists List	Albums List	Songs List
Composers	—	Composers List	Albums List	Songs List	—
Audiobooks	—	Audiobooks List	—	—	—
Shuffle Songs	—	—	—	—	—

Turn and press the “TUNE” dial to select the category. To return to the upper layer, press the “BACK” button. To return to the 1st layer, press the “LIST” button.

■ Display selection (type B audio)

If you press the  button during playback, the indication will change to the next one in the following sequence.

For USB storage device:



For iPod®:

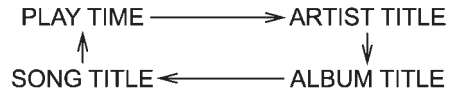

▼ Page scroll

Refer to “Page (track/folder title) scroll” 5-28.



■ Folder selection (only when connecting USB storage device)

Refer to “Folder selection” 5-28.

NOTE

When an iPod® is connected, you cannot select a folder.

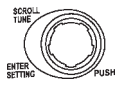
■ Selection from list (only when connecting USB storage device) (type C audio)

“TUNE” dial	
“BACK” button	

You can select folder/track/file(s) from the list. Turn and press the “TUNE” dial to select the folder/track/file. To return to the upper layer, press the “BACK” button.

■ Setting the playing speed (only when the audiobook is playing) (type C audio)

Each time you briefly press the “RPT” button while the audiobook is playing, the playing speed changes in the following sequence.

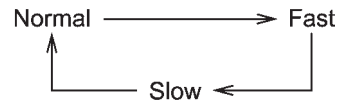

■ When the following messages are displayed

If one of the following messages is displayed while connecting the USB storage device/iPod®, determine the cause based on the following information. If you cannot clear those messages, please contact your SUBARU dealer.

Message	Cause	Action
"CHECK DEVICE"	<ul style="list-style-type: none"> ● When there is a short in the USB bus ● When an incompatible device (for example a USB mouse) is connected ● When an incompatible iPod® is connected ● When a connected iPod® is frozen ● When a transmission malfunction occurs ● When an iPod® confirmation malfunction occurs ● When a HUB class USB storage device is connected 	Disconnect the USB storage device/iPod® and check it.
"NO DEVICE" (type B audio) "No USB" (type C audio) "No iPod" (type C audio)	<ul style="list-style-type: none"> ● No USB storage devices/iPod® are connected. ● An incompatible USB storage device/iPod® is connected. 	Connect a supported USB storage device/iPod®.
"NO FILE" (type B audio) "No song" (type C audio)	There are no playable audio files on the connected USB storage device.	Connect a USB storage device that has playable audio files stored on it.
"NO MUSIC" (type B audio) "No Songs" (type C audio)	There are no playable audio files on the connected iPod®.	Connect an iPod® that has playable audio files stored on it.

Audio control buttons

NOTE

For models with the genuine SUBARU navigation system, refer to the Owner's Manual supplement for the navigation system.

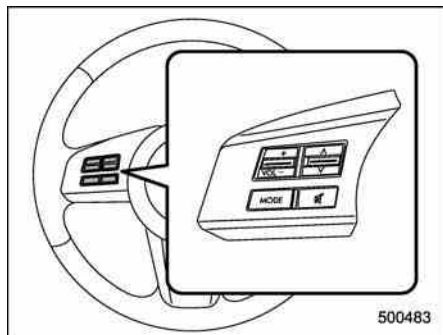

Models without Hands-free system

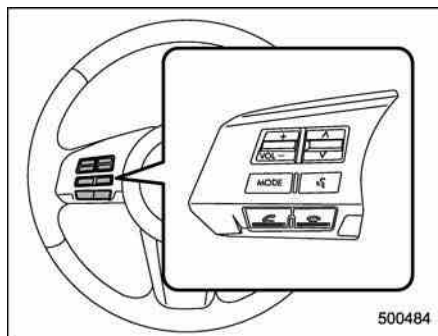

Models with Hands-free system

These buttons are located on the spokes of the steering wheel. They allow the driver to control audio functions without taking his/her hands off the steering wheel.

MODE button

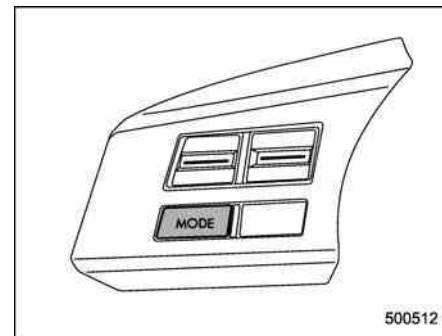

This button is used to select the desired audio mode. Each time it is pressed, the mode changes to the next one in the following sequence.

Type A audio:

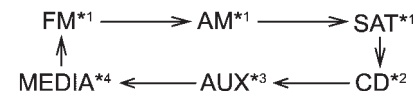

*1: The frequency last received in the selected waveband will be displayed.

*2: Only when a CD is in the player.

*3: Only when an auxiliary audio product is connected.

*4: Only when an iPod is connected using the iPod adapter that is available as a dealer option.

Type B audio:

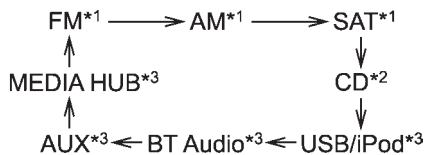

*1: The frequency last received in the selected waveband will be displayed.

*2: Only when a CD is in the player.

*3: Only when the device is connected.

Type C audio:

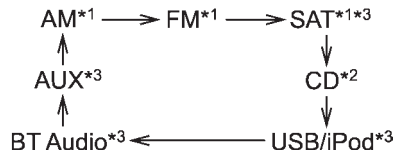

*1: The frequency last received in the selected waveband will be displayed.

*2: Only when a CD is in the player.

*3: Only when the device is connected.

▼ Type B audio

Press and hold this button if you wish to immediately cut the volume to zero.

The audio display will show “MUTE”.

If you press and hold the button again, the original sound volume will return and

“MUTE” turns off.

■ “^” and “v” switch

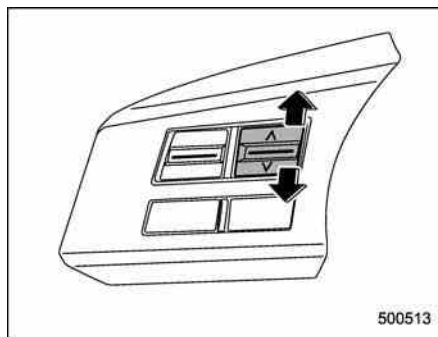

▼ With radio mode selected

Press the switch to the “^” or “v” side briefly to skip to a preset channel. Press and hold the switch to the “^” or “v” side to seek the next receivable station and stop at it.

That station’s frequency will be indicated on the audio display.

▼ With CD/USB/Bluetooth® audio mode selected

Press the switch to the “^” side briefly to skip forward in the track/file order. Press the switch to the “v” side briefly to skip backward in the track/file order.

The track/file number will be shown on the audio display.

For type B and C audio, when the MP3/WMA/AAC format track is playing, press and hold the switch to the “^” side to select the next folder. Press and hold the switch to the “v” side to go back to the previous folder.

▼ With iPod® mode selected (type B and C audio)

Press the switch to the “^” side to skip forward in the track/file order. Press the switch to the “v” side to skip backward in the track/file order. The track/file number will be shown on the audio display.

▼ With SAT mode selected (type C audio)

Press the switch to the “^” or “v” side briefly. The radio will seek the next preset channel and stop at it.

Press and hold the switch to the “^” or “v” side. The radio will seek the next receivable channel and stop at it.

The channel will be shown on the audio display.

■ Volume control switch

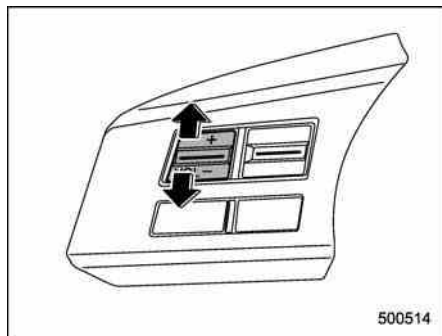

Press the switch to the “+” side to increase the volume. Press the switch to the “-” side to reduce the volume.

A number indicating the volume will be shown on the audio display.

■ MUTE button (if equipped)

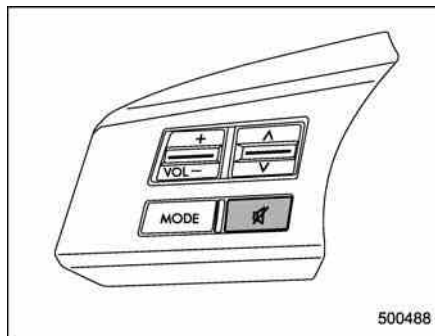

Press this button if you wish to immediately cut the volume to zero.

The audio display will show “MUTE”.

If you press the button again, the original sound volume will return and “MUTE” turns off.

Bluetooth® audio (type B and C audio)

NOTE

For models with the genuine SUBARU navigation system, refer to the Owner's Manual supplement for the navigation system.



NOTE

The Bluetooth word mark and logo are registered trademarks of Bluetooth SIG, Inc.

This function enables you to play back audio sources from Bluetooth® audio devices. You need to register the Bluetooth® audio device in the system before using it.

NOTE

● The Bluetooth® audio function may not operate properly under the following conditions.

- The device is turned off.
- The battery of the device has run down.
- The device is not connected to the system.
- The device is behind the seat or in the glove box.
- A metal material is covering or touching the device.

● Depending on the type of device that is used, operation and sound volume may be different from normal use of those devices.

● The sound quality may degrade due to the influence of the device that is connected to the system or the circumstances of the Bluetooth network.

● When another Bluetooth® device is simultaneously connected, noise may be heard.

■ Media format

Bluetooth® audio devices cannot be connected if they are not compatible with the following Bluetooth® profiles.

● A2DP (Advanced Audio Distribution Profile)

● AVRCP (Audio/Video Remote Control Profile)

■ Setting Bluetooth® audio (type B audio)

1. Select “BT-A SETUP” by pressing the “MENU” button.
2. Perform the following procedure by operating the “TUNE” dial while “BT-A” is displayed.

NOTE

You cannot set Bluetooth® audio while driving.

▼ Registering (pairing) device**NOTE**

Only one device can be registered.

1. Select the “PAIR AUDIO” menu.
 - If a device is already registered, “MEMORY FULL” is displayed and the mode changes to the Bluetooth® audio setting mode.
2. After the passkey is shown on the display, input the passkey into the device.
 - If the registering procedure is finished, “PAIRED” and the name of the device are displayed.
 - If the registering procedure was not successful, “FAILED” is displayed.

After the name of the device or “FAILED” is displayed, the mode changes to the Bluetooth® audio setting mode.

NOTE

After the ignition switch is turned to the “LOCK” position, the registered device is not automatically connected to the system even if the ignition switch is turned to the “Acc” or “ON” position.

▼ Selecting device

1. Select the “SELECT AUDIO” menu.
 - If no devices are registered, “EMPTY” is displayed and the mode changes to the Bluetooth® audio setting mode.
2. Select the “CONFIRM” menu.
 - Then the name of the selected device is displayed.
 - If the device is connected, “SELECTED” is displayed and the mode changes to the Bluetooth® audio setting mode.
 - If the device cannot be connected, “FAILED” is displayed and the selecting procedure was not successful.

▼ Setting passkey

1. Select the “SET PASSKEY” menu.
 - After the currently set passkey is displayed, a new passkey can be

entered.

- Input the new passkey (a 4 - 8 digit number) by operating the "TUNE" dial.
- Select the "CONFIRM" menu.
 - The new passkey is displayed, the passkey is changed and the mode changes to the **Bluetooth**® audio setting mode.

▼ Deleting device

- Select the "DELETE AUDIO" menu.
 - If no devices are registered, "EMPTY" is displayed and the mode changes to the **Bluetooth**® audio setting mode.
- Select the "CONFIRM" menu.
 - "DELETED" is displayed and the mode changes to the **Bluetooth**® audio setting mode.

■ Setting Bluetooth® audio (type C audio)

- Press the  button to select the "BT Audio" mode.

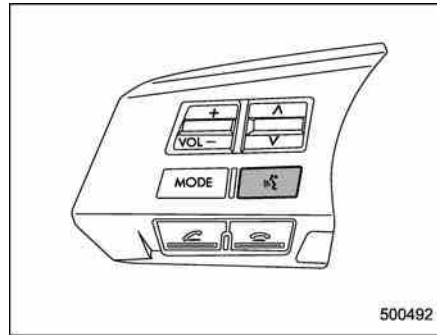



Talk switch

- Press the talk switch .

NOTE

If a device and a cell phone are already registered, "BT" menu will be displayed. Then perform the following procedure.

- Press the talk switch  and say "Setup".
- Press the talk switch  again and say "Bluetooth audio setup". The "BT Audio Setup" will then be displayed.
- After the "BT Audio Setup" menu is displayed, select the following menus by using the voice command system or by operating the "TUNE" dial.

NOTE

- You cannot set Bluetooth® audio while driving.
- After the ignition switch is turned to the "LOCK" position, the registered device/cell phone may be automatically connected to the system if the ignition switch is turned to the "Acc" or "ON" position.
- When a cell phone is already connected, the system will disconnect the phone to setup a new device. You may need to reconnect the phone after setup is complete.
- Up to 2 devices (excluding cell phones for Hands-free system) can be registered.
- Up to 6 devices (including cell phones for Hands-free system) can be registered.



▼ By using voice command system

NOTE





If no devices are registered, you can only select from the following menu.

- "Pair audio player" (refer to "Registering (paring) device" 5-46)
- "Set passkey" (refer to "Selecting device" 5-46)

▽ Registering (paring) device





1. Press the talk switch  and say "Pair audio player".
2. Press the talk switch  and say the name of the device to be registered.
3. Press the talk switch .
4. Say "Confirm" to register the device, or say "Go back" to go back.
5. After saying "Confirm", the passkey will be shown on the display. Then input the passkey into the device.
 - If the registering procedure is finished, "Audio Players Paired." will be displayed.
 - If the registering procedure was not successful, "Unable to pair audio players." will be displayed.

▽ Selecting device

1. Press the talk switch  and say "Select audio player".
2. Press the talk switch .
3. Say the name of the registered device, or "List audio players" and select the registered device (for details, refer to "List audio player function" 5-46).
4. Press the talk switch  and say "Confirm".
5. Press the talk switch  and say "From car" or "From audio".

6. Press the talk switch .
7. Say "Confirm" to select the device, or say "Go back" to go back.
 - If the device is connected, "Selected" will be displayed.
 - If the device cannot be connected, "Failed" will be displayed.



▽ Changing the registered name

1. Press the talk switch  and say "Change name".
2. Press the talk switch .
3. Say the name of the registered device, or "List audio players" and select the registered device (for details, refer to "List audio player function" 5-46).
4. Press the talk switch .
5. Say "Confirm" to select the device, or say "Go back" to go back.
6. After saying "Confirm", press the talk switch .
7. Say a new name to be registered.
8. Press the talk switch .
9. Say "Confirm" to change the name, or say "Go back" to go back.
 - If the name is changed, "Name changed." will be displayed.



▽ List audio player function

The names of the registered devices are



spoken by using the list audio player function. To use the list audio player function, perform the following procedure.

1. Press the talk switch  and say "List audio player".
 - The names will then be spoken.
2. Press the talk switch  while the name is being spoken to select the device.
 - After the talk switch is pressed, "Audio player selected." will be displayed.
3. Press the talk switch  and say the following words.
 - "Select audio player" (refer to "Selecting device" 5-46)
 - "Change name" (refer to "Changing the registered name" 5-46)
 - "Delete audio player" (refer to "Deleting device" 5-47)

▽ Setting passkey

1. Press the talk switch  and say "Set passkey".
2. Press the talk switch  and say the new passkey (a 4 - 8 digit number).
3. Press the talk switch .
4. Say "Confirm" to set the passkey, or say "Go back" to go back.
 - If the passkey is set, the new passkey will be displayed.

▽ Deleting device

1. Press the talk switch  and say "Delete audio player".
2. Press the talk switch .
3. Say the name of the device, or "List audio player" and select the device (for details, refer to "List audio player function" [☞ 5-46](#)).
4. Press the talk switch .
5. Say "Confirm" to delete the device, or say "Go back" to go back.
 - If the device is deleted, "Deleted." will be displayed.

▼ By operating the dial

Select the menu by turning and pressing the "TUNE" dial.

NOTE

- **Select the "Go Back" menu to go back to the previous menu.**
- **If no devices are registered, you can only select from the following menu.**
 - "Pair Audio Players" to register the device (refer to "Registering (paring) device" [☞ 5-47](#))
 - "Set Passkey" to set a new passkey (refer to "Setting passkey" [☞ 5-48](#))

▽ Registering (paring) device

1. Select the "Pair Audio Players" menu.
2. Select the "Record Name" menu.
3. Say the name of the device to be registered.
4. Select the "Confirm pair audio?" menu.
 - The passkey will then be shown on the display.
5. Input the passkey into the device.
 - If the registering procedure is finished, "Audio Players Paired." will be displayed.
 - If the registering procedure was not successful, "Unable to pair audio players." will be displayed.

▽ Selecting device

1. Select the "Select Audio Player" menu.
2. Select the preferred device.
3. Select the "Confirm select audio player?" menu.
4. Select the "From Car" menu or "From Audio Player" menu.
5. Select the "Confirm select audio player?" menu.
 - If the device is connected, "Selected" will be displayed.
 - If the device cannot be connected, "Failed" will be displayed.

▽ Changing the registered name

1. Select the "Change Name" menu.
2. Select the preferred device.
3. Select the "Record Name" menu.
4. Say the new name.
5. Select the "Confirm name change?" menu.
 - If the name is changed, "Device name has been changed." will be displayed.

▽ List audio player function

For details about the list audio player function, refer to "List audio player function" [☞ 5-46](#).

1. Select the "List Audio Players" menu.
 - The names will then be spoken.
2. Press the talk switch  while the name is being spoken to select the device.
 - After the talk switch is pressed, "Audio player selected." will be displayed.
3. Select from the following menu.
 - "Select Audio Player" (refer to "Selecting device" [☞ 5-47](#))
 - "Change name" (refer to "Changing the registered name" [☞ 5-47](#))
 - "Delete Audio Player" (refer to "Deleting device" [☞ 5-48](#))

▽ Setting passkey

1. Select the “Set Passkey” menu.
2. Press the “TUNE” dial.
3. Input the new passkey (a 4 - 8 digit number) by turning and pressing the “TUNE” dial.
4. After inputting the new passkey, press the “TUNE” dial again.
 - If the passkey is set, the new passkey will be displayed.

▽ Deleting device

1. Select the “Delete Audio Player” menu.
2. Select the preferred device.
3. Select the “Confirm delete audio Player?” menu.
 - If the device is deleted, “Audio player has been deleted.” will be displayed.

■ Bluetooth® audio operation

NOTE

Depending on the connected device, it may not activate as per the following items or not work smoothly. Refer to the instruction manual of the connected device.

▼ How to play back

Type B audio	CD/AUX
Type C audio	CD/AUX

Press the “CD/AUX” button and select the “BT-A” (type B audio)/“BT Audio” (type C audio) mode.

▼ To select a track from the beginning

Select a track in the same way as for a CD. Refer to “To select a track from the beginning” 5-24.

▼ Repeating (type B audio)

Repeating is operated in the same way as for a CD. Refer to “Repeating” 5-26. Each time you briefly press the  button, the mode changes in the following sequence.

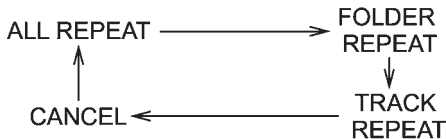

▼ Random playback (type B audio)

Random playback is operated in the same way as for a CD. Refer to “Random

playback” 5-27. Each time you press and hold the  button, the mode changes in the following sequence.

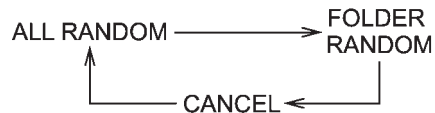

▼ Display selection (type B audio)

Select an indication in the same way as for a CD. Refer to “Display selection (type A and B audio)” 5-28. Each time you briefly press the  button, the indication changes in the following sequence.

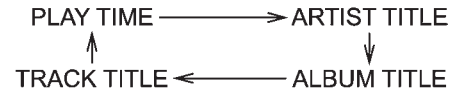

▼ Fast-forwarding and rewinding (type C audio)

Fast-forwarding and rewinding are operated in the same way as for a CD. Refer to “Fast-forwarding and rewinding” 5-25.

▼ Folder selection

Select a folder in the same way as for a CD. Refer to “Folder selection” 5-25.

Hands-free system (if equipped)

NOTE

- For models with the genuine SUBARU navigation system, refer to the Owner's Manual supplement for the navigation system.
- When selling your vehicle, make sure that you initialize the Hands-free system to prevent personal data from being improperly accessed.

The Hands-free system operates while the ignition switch is in the "Acc" or "ON" position.

■ Tips for the Hands-free system

▼ Bluetooth®

It is possible to connect a cell phone to the in-vehicle equipment through the **Bluetooth®** format (wireless) to make a phone call from the in-vehicle equipment or take an incoming phone call.

Since the **Bluetooth®** format is wireless, a connection between the in-vehicle equipment and the cell phone can be made without placing them in close vicinity of each other. The cell phone can be used with it left in the breast pocket or bag.

NOTE

- The Hands-free system may not operate properly under the following conditions.
 - The cell phone is turned off.
 - The cell phone is not in the phone call area.
 - The battery of the cell phone has run down.
 - The cell phone is not connected to the Hands-free system.
 - The cell phone is behind the seat or in the glove box.
 - A metal material covers or touches the cell phone.
- Depending on the type of cell phone that is used, the screen on the cell phone may remain illuminated while the ignition switch is in the "ON" position. If this occurs, turn the illumination off by adjusting the cell phone settings.
 - Depending on the setting of the cell phone, the dial lock function may be activated after making a call. Deactivate the automatic dial lock function of the cell phone before using the Hands-free system.
 - Depending on the type of cell phone that is used, operation and the sound volume may be different from those of cell phones currently used.

- When the ignition switch is turned to the "LOCK" position during a call, the call may be disconnected or continued on the cell phone depending on the type of cell phone that is used. Note that operation of the cell phone may be necessary if the call is continued on the cell phone.
- Do not speak at the same time as the other party during a call. If you and the party speak at the same time, it may be difficult for the other party to hear your voice and vice versa. This is normal.
- The receiver sound volume should be set as low as possible. Otherwise, the party you are calling may notice an undesirable echo sound.
- Speak clearly and loudly.
- Your voice may be difficult to be heard by the party under the following conditions.
 - Driving on a rough road.
 - Driving at a high speed.
 - Driving with a window open.
 - When air from the ventilator blows directly towards the microphone.
 - When the sound coming from the ventilator is loud.
 - When the cell phone is too close to the microphone.

- The sound quality may degrade due to the influence of the cell phone that is connected to the system or the circumstances of the Bluetooth network.

- When another Bluetooth® device is simultaneously connected, noise may be heard in the voice coming from the hands-free phone.

▼ Corresponding profiles for the cell phone

- HFP (Hands Free Profile): Ver. 1.0
- OPP (Object Push Profile): Ver. 1.1

■ Certification for the Hands-free system



CAUTION

FCC WARNING

Changes or modifications not expressly approved by the party responsible for compliance could void the user's authority to operate the equipment.

FCC ID: ACJ932C5ZZZ035

IC ID: 216J-C5ZZZ035

Made in Japan

NOTE

This device complies with Part 15 of the FCC Rules and Industry Canada licence-exempt RSS standard(s). Operation is subject to the following two conditions: (1) this device may not cause harmful interference, and (2) this device must accept any interference, including interference that may cause undesired operation of this device.

NOTE

This equipment has been tested and found to comply with the limits for a Class B digital device, pursuant to Part 15 of the FCC Rules. These limits are designed to provide reasonable protection against harmful interference in a residential installation. This equipment may cause harmful interference to radio communications, if it is not installed and used in accordance with the instructions. However, there is no guarantee that interference will not occur in a particular installation. If this equipment does cause harmful interference to radio or television reception, which can be determined by turning the equipment off and on, the user is encouraged to try to correct the interference by one or more of the following measures.

- Reorient or relocate the receiving antenna.

- Increase the separation between the equipment and receiver.

- Connect the equipment into an outlet on a circuit different from that to which the receiver is connected.

- Consult the dealer or an experienced radio/TV technician for help.

- Changes or modifications not expressly approved by the party responsible for compliance could void the user's authority to operate the equipment.

- This equipment complies with FCC/IC radiation exposure limits set forth for an uncontrolled equipment and meets the FCC radio frequency (RF) Exposure Guidelines in Supplement C to OET65 and RSS-102 of the IC radio frequency (RF) Exposure rules. This equipment has very low levels of RF energy that it deemed to comply without maximum permissive exposure evaluation (MPE). But it is desirable that it should be installed and operated keeping the radiator at least 20 cm or more away from person's body (excluding extremities: hands, wrists, feet and ankles).

- **This transmitter must not be co-located or operated in conjunction with any other antenna or transmitter.**

▼ Mexico models

▽ Type B audio

Este equipo opera a título secundario, consecuentemente, debe aceptar interferencias perjudiciales incluyendo equipos de la misma clase y puede no causar interferencias a sistemas operando a título primario.

500612

Módulo Bluetooth instalado en el interior de la radio

COFETEL RCPCLPF10-1252

Clarion

PF-3380I-A

500614

▽ Type C audio

- **Certificación para la unidad del teléfono manos libres**

Este equipo tiene instalado una unidad de manos libres Bluetooth® (Tipo: C5ZZZ0000042). C5ZZZ0000042 cumple con la LEY FEDERAL DE TELECOMUNICACIONES.
No. de certificación es COFETEL: RCPAC507-889-A5.

Este equipo opera a título secundario, consecuentemente, debe aceptar interferencias perjudiciales incluyendo equipos de la misma clase y puede no causar interferencias a sistemas operando a título primario.

500621

- **Certificación para la unidad del teléfono manos libres**

Este equipo tiene instalado una unidad de manos libres Bluetooth® (Tipo: C5ZZZ0000043). C5ZZZ0000043 cumple con la LEY FEDERAL DE TELECOMUNICACIONES.

No. de certificación es COFETEL: RCPAC507-889-A6.

Este equipo opera a título secundario, consecuentemente, debe aceptar interferencias perjudiciales incluyendo equipos de la misma clase y puede no causar interferencias a sistemas operando a título primario.

500623

■ Safety precautions

▲ WARNING

- For safety reasons, avoid operating the cell phone while driving.
- Do not make a phone call while driving. When you have an incoming call, stop the vehicle in a safe location before taking the incoming phone call. When you have to absolutely take a phone call, tell the caller "I'll call you back". And then call the caller back after stopping the vehicle in a safe location.

• Part 15 FCC Rules

FCC Warning:

Any unauthorized changes of modifications to this equipment would void the user's authority to operate this device.

▲ CAUTION

- Do not leave the cell phone in the vehicle. The temperature in the vehicle may become extremely high and cause a malfunction of the cell phone.

- When using the cell phone, be careful not to get it close to the in-vehicle equipment. Getting it too close to the in-vehicle equipment may result in deterioration in tone quality or a poor connecting condition.
- In the frequency band used by this equipment, along with industrial, scientific and medical equipment such as a microwave oven, radio stations (a license is required) to be used by the production line in the factory to identify movable bodies, specific small power radio stations (a license is not required) and amateur radio stations (a license is required) are being operated. (These three types of radio stations are hereinafter referred to as "other radio stations".) Before using this equipment, be sure to check to see if "other radio stations" are being operated in the vicinity. If there is detrimental radio interference from this equipment to "other radio stations", move the equipment to another location as soon as possible to avoid radio interference. The frequency band used

by this equipment is in the 2.4 GHz zone. The FH-SS modulation is employed as a modulation method. The expected inflicting interference distance is less than 33 ft (10 m). This equipment uses a full band and can avoid a band used by a movable body identification device.

■ Using the Hands-free system

▼ Turning on/off the Hands-free mode

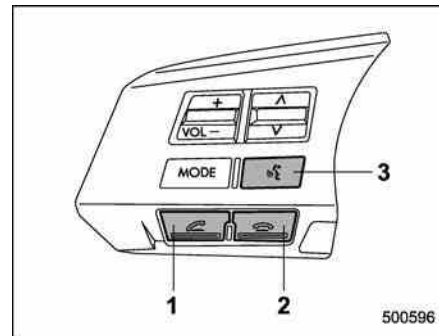

- 1) OFF hook switch
- 2) ON hook switch
- 3) Talk switch

To turn on the Hands-free mode, press the OFF hook switch . To turn off the

Hands-free mode, press the ON hook switch .



▼ **Preparation for using the Hands-free system**

Before using the Hands-free system, it is necessary to register a cell phone in the system. Perform the following procedure to register a cell phone.

NOTE



- Up to 5 cell phones can be registered (for type B audio).
- Up to 6 cell phones (including Bluetooth® audio devices) can be registered (for type C audio).
- When the ignition switch is turned to the “Acc” or “ON” position, the registered cell phone may be automatically connected to the system.

▽ **Registering by operating dial “TUNE” dial:**

Type B audio	
Type C audio	

Select the menus by operating the “TUNE” dial.

Type B audio:

1. Press the OFF hook switch .
2. Select “ENGLISH”/“FRANÇAIS” by operating the “TUNE” dial.
 - “WELCOME!” will then be displayed.
3. Press the “TUNE” dial or the talk switch .
4. Select the “RECORD NAME” menu, or press the talk switch .
5. Say the name to be registered.
6. Select the “CONFIRM” menu.
 - After “CAR M_MEDIA” is displayed, a pass key will be displayed.
7. Input the displayed pass key into the cell phone while “PKY: ****” is displayed.

Type C audio:

1. Press the OFF hook switch .
 - If no cell phone is registered, “Welcome!!” is shown on the screen. In this case, perform the procedure after step 4.
2. Select the “Setup” menu.
3. Select the “Phone Setup” menu.
4. Select the “Pair Phone” menu.
5. Select the “Record Name” menu.
6. Say the name to be registered.

7. Select the “Confirm pair phone?” menu.

8. Select the “Phone Only” menu to register only a cell phone, or select “Int. Audio” menu to register internal audio in addition to the cell phone.





9. After “Car Multi-Media” is displayed, a pass key will be displayed.



10. Input the displayed pass key into the cell phone while “Passkey: ****” is displayed.

▽ **Registering by using voice command system (type C audio)**

NOTE

If no cell phone is registered, when the OFF hook switch  is pressed, “Welcome!!” is shown on the screen. In this case, perform the procedure after step 4.

1. Select a mode other than “BT Audio” mode.
2. Press the talk switch  and say “Setup”.
3. Press the talk switch  and say “Phone Setup”.
4. Press the talk switch  and say “Pair Phone”.
5. Press the talk switch  and say the name to be registered.

6. Press the talk switch  and say "Confirm".
7. Press the talk switch .
8. Say "Phone Only" to register only a cell phone, or say "Internal Audio" to register internal audio in addition to the cell phone.
9. Press the talk switch  and say "Confirm pair phone?".
 - After "Car Multi-Media" is displayed, a pass key will be displayed.
10. Input the displayed pass key into the cell phone while "Passkey: *****" is displayed.

▼ Menu list of the Hands-free system

Turn the "TUNE" dial to select a menu, and then press the dial to enter the selected menu.

▽ **Type B audio**

First menu	Second menu	Third menu	Details	Page
PHONE BOOK*	ADD ENTRY	BY VOICE	Adding a new number by voice	5-62
		BY PHONE	Adding a new number by cell phone	5-62
		MANUAL INPUT	Adding a new number by inputting manually	5-63
		CALL HISTORY	Adding a new number from the call history	5-63
		GO BACK		
	LIST NAMES	—	Showing the list of the names registered in the phonebook	5-64
	CHANGE NAME	—	Changing a name registered in the phonebook	5-64
	SET SPD DIAL	—	Registering a speed dial	5-65
	DELETE ENTRY	—	Deleting phonebook data	5-65
	DEL SPD DIAL	—	Deleting a registered speed dial	5-65
GO BACK	—			
REDIAL	DIAL	—	Dialing a number stored in the outgoing call history memory	5-66
	STORE	—	Adding a new number stored in the outgoing call history memory	5-63
	DELETE	—	Deleting a number stored in the outgoing call history memory	5-65
	GO BACK	—		
CALLBACK	DIAL	—	Dialing a number stored in the incoming call history memory	5-66
	STORE	—	Adding a new number stored in the incoming call history memory	5-64
	DELETE	—	Deleting a number stored in the incoming call history memory	5-66
	GO BACK	—		

*: If a cell phone is not registered, the menu described in the chart is not indicated.

First menu	Second menu	Third menu	Details	Page
SETUP	SECURITY	SET PIN	Setting a PIN code	5-67
		PHBK LOCK ^{*1}	Locking the phonebook	5-67
		PHBK UNLOCK ^{*1}	Unlocking the phonebook	5-68
		GO BACK		
	PHONE SETUP	PAIR PHONE	Registering a new cell phone ^{*2}	5-53
		SELECT PHONE	Selecting a cell phone to be used	5-68
		CHANGE NAME	Changing the registered name of the cell phone	5-68
		LIST PHONES	Showing the list of the registered cell phones	5-69
		SET PASSKEY	Changing the pass key	5-69
		DELETE	Deleting the registered cell phone	5-69
		GO BACK		
	SYSTEM SETUP	GUIDANCE VOL	Setting the volume of the voice guidance	5-70
		INITIALIZE	Initialization	5-70
		SEL LANGUAGE	Selecting the language (using the Hands-free system)	5-70
		GO BACK		
GO BACK	—			

*1: If a PIN code is not registered, the menu described in the chart is not available.

*2: Up to 5 cell phones can be registered.

▽ **Type C audio**

First menu	Second menu	Third menu	Details	Page
Phonebook*	Add Entry	By Voice	Adding a new number by voice	5-62
		By Phone	Adding a new number by cell phone	5-62
		Manual Input	Adding a new number by inputting manually	5-63
		Call History	Adding a new number from the call history	5-63
		Go Back		
	Change Name	—	Changing a name registered in the phonebook	5-64
	List Names	—	Showing the list of the names registered in the phonebook	5-64
	Speed Dial	—	Registering a speed dial	5-65
	Delete Entry	—	Deleting phonebook data	5-65
	Delete Speed Dial	—	Deleting a registered speed dial	5-65
Go Back	—			
Redial*	Dial	—	Redialing	5-66
	Store	—	Adding a new number stored in the outgoing call history memory	5-63
	Delete	—	Deleting a number stored in the outgoing call history memory	5-65
	Go Back	—		
CallBack*	Dial	—	Dialing a number stored in the incoming call history memory	5-66
	Store	—	Adding a new number stored in the incoming call history memory	5-64
	Delete	—	Deleting a number stored in the incoming call history memory	5-66
	Go Back	—		

*: If a cell phone is not registered, the menu described in the chart is not indicated.

First menu	Second menu	Third menu	Details	Page
Setup	Security ^{*1}	Set PIN	Setting a PIN code	5-67
		Phonebook Lock	Locking the phonebook	5-67
		Phonebook Unlock	Unlocking the phonebook	5-68
		Go Back		
	Phone setup	Pair Phone	Registering a new cell phone ^{*3}	5-53
		Select Phone ^{*1}	Selecting a cell phone to be used	5-68
		Change Phone Name ¹	Changing the registered name of the cell phone	5-68
		List Phones ^{*1}	Showing the list of the registered cell phones	5-69
		Set Passkey	Changing the pass key	5-69
		Delete Phone ^{*1}	Deleting the registered cell phone	5-69
		Handsfree Power ^{*1}	Turning the Hands-free power ON/OFF	5-69
		Go Back		
	BT Audio Setup ^{*1}	Pair Audio Players	Registering an audio player (device) ^{*3}	5-47
		Select Audio Player ^{*2}	Selecting the registered audio player (device)	5-47
		Change Name ^{*2}	Changing the name of the registered audio player (device)	5-47
		List Audio Players ^{*2}	Speaking the names of the registered audio players (devices)	5-47
		Set Passkey	Setting a new passkey for the registered audio player (device)	5-48
		Delete Audio Player ^{*2}	Deleting the registered audio player (device)	5-48
		Go Back		

*1: If a cell phone is not registered, the menu described in the chart is not indicated.

*2: If a device is not registered, the menu described in the chart is not indicated.

*3: Up to 6 cell phones and Bluetooth[®] audio devices can be registered.

First menu	Second menu	Third menu	Details	Page
Setup	System setup*	Guidance Volume	Setting the volume of the voice guidance	5-70
		Device Name	Showing the device name and BD address of the audio	5-70
		Reset Settings	Initialization	5-70
		Go Back		
	Go Back	—		

*: If a cell phone is not registered, the menu described in the chart is not indicated.

▼ Voice command system

NOTE

Press the talk switch  and say "Help" to listen to the help guidance.

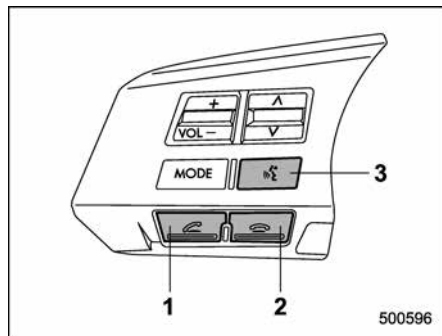

- 1) OFF hook switch
- 2) ON hook switch
- 3) Talk switch

To turn on the voice command system, press the talk switch  briefly. To turn off the voice command system, wait for 5 seconds without using the voice command system.

The commands available for the voice command system are listed in the following charts.

▼ Type B audio

	Command	
	English	Français
1	0 (zero, oh)	0 (zéro)
2	1 (one)	1 (un)
3	2 (two)	2 (deux)
4	3 (three)	3 (trois)
5	4 (four)	4 (quatre)
6	5 (five)	5 (cinq)
7	6 (six)	6 (six)
8	7 (seven)	7 (sept)
9	8 (eight)	8 (huit)
10	9 (nine)	9 (neuf)
11	* (star)	* (étoile)
12	# (pound)	# (carré, dièse)
13	+ (plus)	+ (plus)
14	callback	rappel
15	redial	recomposer
16	dial by number	composer par numéro
17	dial by name	composer par nom
18	phonebook	registre

19	setup	réglages
20	phone book add entry	ajouter l'entrée dans le registre
21	phone book change name	modifier le nom dans le registre
22	phone book delete entry	supprimer l'entrée du registre
23	phone book list names	lister les noms du registre
24	phone book set speed dial	configurer composition abrégée pour le registre
25	phone book delete speed dial	supprimer composition abrégée pour le registre
26	phone book unlock	déverrouiller le registre
27	cancel	annuler
28	help	aide
29	repeat	répéter
30	go back	retourner
31	dial	composer
32	previous	précédent
33	delete	supprimer
34	store	enregistrer
35	confirm	confirmer
36	phone setup	réglages du téléphone

37	security	sécurité
38	pair phone	jumeler le téléphone
39	change name	modifier le nom
40	select phone	sélectionner le téléphone
41	list phones	lister les téléphones
42	set pass key	configurer le passe-partout
43	add entry	ajouter l'entrée
44	delete entry	supprimer l'entrée
45	delete speed dial	supprimer composition abrégée
46	by voice	vocalement
47	by phone	par téléphone
48	call history	historique d'appels
49	set speed dial	configurer composition abrégée
50	incoming	entrant
51	outgoing	sortant
52	list names	lister les noms
53	set PIN	configurer NIP
54	phone book lock	verrouiller le registre

▽ **Type C audio**

	Command	
	English	Français
1	0 (zero, oh)	0 (zéro)
2	1 (one)	1 (un)
3	2 (two)	2 (deux)
4	3 (three)	3 (trois)
5	4 (four)	4 (quatre)
6	5 (five)	5 (cinq)
7	6 (six)	6 (six)
8	7 (seven)	7 (sept)
9	8 (eight)	8 (huit)
10	9 (nine)	9 (neuf)
11	* (star)	* (étoile)
12	# (pound)	# (dièse)
13	+ (plus)	+ (plus)
14	add entry	ajouter entrée
15	Bluetooth Audio setup	configuration Audio Bluetooth
16	BT-A setup	configuration Audio Bluetooth
17	BT-Audio setup	configuration Audio Bluetooth
18	by phone	par téléphone
19	by voice	par la voix

20	call history	historique des appels
21	call transfer	transfert d'appel
22	callback	rappel automatique
23	cancel	annuler
24	change name	changer nom
25	confirm	valider
26	delete	supprimer
27	delete audio	supprimer audio
28	delete audio player	supprimer lecteur audio
29	delete entry	supprimer entrée
30	delete phone	supprimer téléphone
31	delete speed dial	supprimer composition rapide
32	dial	composer
33	dial by name	composer par nom
34	dial by number	composer par numéro
35	from audio	depuis audio
36	from car	depuis voiture
37	go back	retour
38	hands free power	alimentation mains libres
39	help	aide
40	incoming	appel d'arrivée

41	internal audio	audio interne
42	list audio players	lister lecteurs audio
43	list names	lister noms
44	list phones	lister téléphones
45	mute	sourdine
46	next	suivant
47	outgoing	appel de départ
48	pair audio player	jumeler lecteur audio
49	pair phone	jumeler téléphone
50	phone book add entry	annuaire ajouter entrée
51	phone book change name	annuaire changer nom
52	phone book delete entry	annuaire supprimer entrée
53	phone book list names	annuaire lister noms
54	phone book lock	annuaire bloquer
55	phone book set speed dial	annuaire définir composition rapide
56	phone book unlock	annuaire débloquent
57	phone only	téléphone uniquement
58	phone setup	configuration téléphone

59	phonebook	annuaire
60	phonebook delete speed dial	annuaire supprimer composition rapide
61	previous	précédent
62	redial	recomposer
63	repeat	répéter
64	security	sécurité
65	select audio player	sélectionner lecteur audio
66	select phone	sélectionner téléphone
67	send	envoyer
68	set pass key	définir mot de passe
69	set PIN	définir NIP
70	set speed dial	définir composition rapide
71	setup	configurer
72	store	enregistrer
73	turn on	activer
74	turn off	désactiver

▼ Updating phonebook data



NOTE

• The maximum number of phonebook entries that can be registered in

the phonebook is 50 (type B audio)/20 (type C audio).

• After registering phonebook data, you can add a phone number to the speed dial memory. For details, refer to “Registering speed dial” 5-64.

▽ Registering by voice

1. Select the “BY VOICE” menu.
2. Press the talk switch .
3. Say the phone number to be registered.
4. Select the “CONFIRM” menu.
5. Perform either of the following procedures.
 - Select the “RECORD NAME” menu by operating the “TUNE” dial.
 - Press the talk switch .
6. Say the name (voice tag) to be registered.
7. Select the “CONFIRM” menu.
 - The phone number is then registered and “STORED” (type B audio)/“Phone number stored.” (type C audio) is displayed.

▽ Registering by phone

1. Select the “BY PHONE” menu.
2. Select the “CONFIRM” (type B audio)/“Confirm Transfer phonebook entry?” (type C audio) menu.

3. Transfer the data from the cell phone. For details about transferring the data, refer to the instruction manual of the cell phone.

NOTE

For type C audio, you can select the data to be registered by performing either of the following procedures until the preferred data is displayed.

- Press the talk switch  and saying "Previous" or "Next".
- Operate the "TUNE" dial.

4. Select the phone number to be registered by operating the "TUNE" dial.
5. Perform either of the following procedures.
 - Select the "RECORD NAME" menu by operating the "TUNE" dial.
 - Press the talk switch .
6. Say the name (voice tag) to be registered.
7. Select the "CONFIRM" menu.
 - The phone number is then registered and "STORED" (type B audio)/"Phone number stored." (type C audio) is displayed.

▽ Registering by inputting manually

1. Select the "MANUAL INPUT" menu by operating the "TUNE" dial.

2. Input the phone number to be registered.
3. Perform either of the following procedures.
 - Select the "RECORD NAME" menu by operating the "TUNE" dial.
 - Press the talk switch .
4. Say the name (voice tag) to be registered.
5. Select the "CONFIRM" menu.
 - The phone number is then registered and "STORED" (type B audio)/"Phone number stored." (type C audio) is displayed.

NOTE

While inputting the phone numbers, if "GO BACK" is chosen using the "TUNE" dial, the character that was input last is deleted.

▽ Registering from call history

1. Select the "CALL HISTORY" menu.
2. Select one of the following menus.
 - "INCOMING" or "OUTGOING" (type B audio)
 - "Incoming Call History" or "Outgoing Call History" (type C audio)
3. Select the phone number by operating the "TUNE" dial.

4. Select the "CONFIRM" menu (type B audio).
5. Perform either of the following procedures.
 - Select the "RECORD NAME" menu by operating the "TUNE" dial.
 - Press the talk switch .
6. Say the name (voice tag) to be registered.
7. Select the "CONFIRM" menu.
 - The phone number is then registered and "STORED" (type B audio)/"Phone number stored." (type C audio) is displayed.

▽ Registering from redial

1. Select the "REDIAL" menu.
2. Select the phone number by operating the "TUNE" dial.
3. Select the "STORE" menu.
4. Select the "CONFIRM" (type B audio)/"Confirm store number?" (type C audio) menu.
5. Perform either of the following procedures.
 - Select the "RECORD NAME" menu by operating the "TUNE" dial.
 - Press the talk switch .
6. Say the name (voice tag) to be registered.

7. Select the “CONFIRM” menu.
 - The phone number is then registered and “STORED” (type B audio)/“Phone number stored.” (type C audio) is displayed.



▽ Registering from call back

1. Select the “CALLBACK” menu.
2. Select the phone number by operating the “TUNE” dial.
3. Select the “STORE” menu.
4. Select the “CONFIRM” (type B audio)/“Confirm store number?” (type C audio) menu.
5. Perform either of the following procedures.
 - Select the “RECORD NAME” menu by operating the “TUNE” dial.
 - Press the talk switch .
6. Say the name (voice tag) to be registered.
7. Select the “CONFIRM” menu.
 - The phone number is then registered and “STORED” (type B audio)/“Phone number stored.” (type C audio) is displayed.

▽ Registering speed dial

1. After registering phonebook data, perform either of the following procedures.
 - Select the “SPEED DIAL” menu by

operating the “TUNE” dial.

- Press the talk switch  and say “SET SPEED DIAL”.
2. Press the preset button (from  to ) to which you want to register the phone number.

NOTE

If the number to be used is already registered in speed dial, “OVERWRITE?” will be displayed. Select the “CONFIRM” menu to overwrite, or select the “GO BACK” menu to cancel.

▽ List names function

The voice tags registered in the phonebook are spoken by using the list names function. To use the list names function, perform the following procedure.

1. Select the “LIST NAMES” menu.
2. Choose the registered data by performing either of the following procedures.
 - Press the talk switch .
 - Operate the “TUNE” dial (type B audio only).

After “SELECTED” is displayed, you can choose the following menus.



- “DIAL” to make a phone call
- “CHANGE NAME” to change the name (voice tag)

- “SET SPD DIAL”/“SET SPEED DIAL”/“Speed Dial” to set the speed dial
- “DELETE ENTRY” to delete the name (voice tag) from the phonebook
- “GO BACK” to go back to the menu mode
- “HELP” to listen to the help guidance (only when using the voice command system)

NOTE

- After “LIST NAMES” is selected, if the OFF hook switch  is pushed, the selected number is called.
- After “LIST NAMES” is selected, if no operation is performed, the memories are displayed and voice tags are spoken. After all memories/voice tags are displayed/spoken, “END OF LIST” is displayed and the mode changes to the “PHONE BOOK” menu mode.

▽ Changing voice tag





1. Select the “PHONE BOOK” menu.
2. Select the “CHANGE NAME” menu.
3. Select the phone number by performing one of the following procedures.
 - Operate the “TUNE” dial.
 - Press the talk switch  and say the voice tag.
 - Press the talk switch , say “List

Names” and use the list names function.

4. Select the “CONFIRM” (type B audio)/ “Confirm name change?” (type C audio) menu (only after saying the voice tag).
 - Then the selected phone number/ name is displayed.
5. Perform either of the following procedures.
 - Select the “RECORD NAME” menu by operating the “TUNE” dial.
 - Press the talk switch .
6. Say the new voice tag.
7. Select the “CONFIRM” (type B audio)/ “Confirm name change?” (type C audio) menu.
 - Then “CHANGED” (type B audio)/ “Name successfully changed.” (type C audio) is displayed.

▽ Set speed dial



1. Perform either of the following procedures.
 - Select the “SET SPD DIAL” menu (type B audio) / “Speed Dial” menu (type C audio) by operating the “TUNE” dial.
 - Press the talk switch  and say “SET SPEED DIAL”.
2. Select the phone number by performing one of the following procedures.

- Operate the “TUNE” dial.
 - Press the talk switch  and say the voice tag.
 - Press the talk switch , say “List Names” and use the list names function (type C audio).
3. Select the “CONFIRM” (type B audio)/ “Confirm Name?” (type C audio) menu (only after saying the voice tag).
 4. Press the preset button (from  to ) to which you want to register the phone number.

NOTE



If the number to be used is already registered in speed dial, “OVERWRITE?” will be displayed. Select the “CONFIRM” (type B audio)/ “Confirm Overwrite speed dial?” (type C audio) menu to overwrite, or select the “GO BACK” menu to cancel.

▽ Deleting the phonebook data

1. Select the “DELETE ENTRY” menu.
2. Select the phone number by performing either of the following procedures.
 - Operate the “TUNE” dial.
 - Press the talk switch  and say the voice tag.
 - Press the talk switch  and use the list names function (type C audio).

3. Select the “CONFIRM” (type B audio)/ “Confirm delete entry?” (type C audio) menu.
 - Then “DELETED” (type B audio)/ “Phonebook entry deleted.” (type C audio) is displayed and the selected phonebook data is deleted.

▽ Deleting the speed dial

1. Select the “DEL SPD DIAL”/“DELETE SPEED DIAL” menu.
2. Press the preset button (from  to ) to which you want to delete the speed dial.
3. Select the “CONFIRM” (type B audio)/ “Confirm delete speed dial entry?” (type C audio) menu.
 - Then “DELETED” (type B audio)/ “Speed dial entry * deleted.” (type C audio) is displayed and the selected speed dial is deleted.

▽ Deleting the redial data

1. Select the “REDIAL” menu.
2. Select the phone number by operating the “TUNE” dial.
3. Select the “DELETE” menu.
4. Select the “CONFIRM” (type B audio)/ “Confirm delete number?” (type C audio) menu.
 - Then “DELETED” is displayed and



the selected redial data is deleted.

▽ Deleting the callback data



1. Select the "CALLBACK" menu.
2. Select the phone number by operating the "TUNE" dial.
3. Select the "DELETE" menu.
4. Select the "CONFIRM" (type B audio)/ "Confirm delete number?" (type C audio) menu.
 - Then "DELETED" is displayed and the selected callback data is deleted.

▼ Making a phone call

▽ Making a phone call by saying name

1. Press the talk switch .
2. Say "DIAL BY NAME".
3. Press the talk switch  again.
4. Say the preferred name (voice tag) to be called. For type C audio, you can use the list names function.
5. Select the "DIAL" menu, or press the OFF hook switch .

▽ Making a phone call by saying number



1. Press the talk switch .
2. Say "DIAL BY NUMBER".
3. Press the talk switch  again.

4. Say the preferred phone number to be called.

5. Select the "DIAL" menu, or press the OFF hook switch .

▽ Making a phone call from speed dial

It is possible to select a phone number from speed dial registered with the in-vehicle equipment to make a phone call.

1. Select the top menu (phone menu).
2. Press the preset button (from  to ) to which the preferred number is registered.
3. Press the OFF hook switch .

NOTE

When a preset button for which numbers are not registered is pressed, an error message is indicated on the audio screen.

▽ Redial

1. Select the "REDIAL" menu.
2. Select the preferred number by turning the "TUNE" dial.
3. Perform either of the following procedures.
 - Press the OFF hook switch .
 - Select the "DIAL" menu.



▽ Callback

1. Select the "CALLBACK" menu.
2. Select the preferred number by turning the "TUNE" dial.
3. Perform either of the following procedures.
 - Press the OFF hook switch .
 - Select the "DIAL" menu.

▽ Making a phone call from list name

It is possible to select a phone number from the list name registered with the in-vehicle equipment to make a phone call. For details, refer to "List names function" 5-64.

▽ Top redial

1. Select the top menu (phone menu).
2. Press the OFF hook switch  and load the outgoing call history.
3. Select the preferred number by turning the "TUNE" dial.
4. Perform either of the following procedures.
 - Press the OFF hook switch .
 - Select the "DIAL" menu.

▼ Taking a phone call and declining an incoming call

To take a phone call: Press the OFF hook switch .

To put an incoming call on hold (only if the cell phone has this function): Press the ON hook switch  briefly.

To decline an incoming call (only if the cell phone has this function): Press and hold the ON hook switch .

▼ Ending a call

Press the ON hook switch .

▼ Volume control

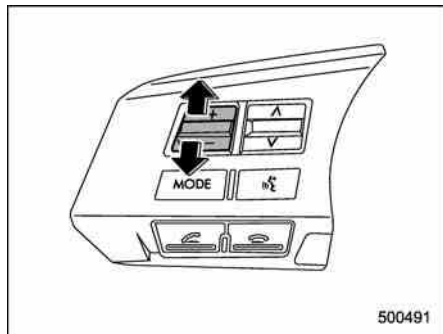

You can adjust the phone call volume, the voice volume and the voice guidance volume. Refer to “Volume control switch” 5-43.

▽ Adjustable level of each volume

Volume	Range	Initial setting
Phone call	0 to 14	7
Voice	0 to 14	7
Voice guidance	0 to 6 ^{*1} 1 to 7 ^{*2}	3 ^{*1} 4 ^{*2}

*1: type B audio

*2: type C audio

■ Bluetooth® setting

▼ Security setting

After selecting the “SECURITY” menu, perform the following procedure.

▽ Setting PIN code

The PIN code is a 4-digit number and is used when locking the phonebook.

1. Select the “SET PIN” menu.
2. Input the current PIN code by performing one of the following procedures.
 - Operate the “TUNE” dial.
 - Press the talk switch  and say the number.
3. Select the “CONFIRM” (type B audio)/“Confirm PIN?” (type C audio) menu.
4. Input the new PIN code by performing one of the following procedures.
 - Operate the “TUNE” dial.

– Press the talk switch  and say the number.

5. Select the “CONFIRM” (type B audio)/“Confirm PIN?” (type C audio) menu.

▽ Locking the phonebook

1. Select the “PHBK LOCK”/“PHONEBOOK LOCK” menu.

NOTE

If the phonebook is locked, “LOCKED” (type B audio)/“The phonebook is locked.” (type C audio) is displayed and the mode changes to the security mode.

2. Input the PIN code by performing one of the following procedures.
 - Operate the “TUNE” dial.
 - Press the talk switch  and say the number.
3. Select the “CONFIRM” (type B audio)/“Confirm PIN?” (type C audio) menu.
 - If the inputted PIN code is correct, “LOCKED” (type B audio)/“The phonebook is locked.” (type C audio) will be displayed and the phonebook is locked.

NOTE

While the phonebook is locked, if the operation restricted menu is selected, “PHBK LOCK” (type B audio)/“Phonebook locked!” (type C audio) is displayed.

▽ Unlocking the phonebook

1. Select the “PHBK UNLOCK”/“PHONEBOOK UNLOCK” menu.

NOTE

If the phonebook is not locked, “UNLOCK” (type B audio)/“The phonebook is unlocked.” (type C audio) is displayed and the mode changes to the security mode.

2. Input the PIN code by performing one of the following procedures.
 - Operate the “TUNE” dial.
 - Press the talk switch  and say the number.
3. Select the “CONFIRM” (type B audio)/“Confirm PIN?” (type C audio) menu.
 - If the inputted PIN code is correct, “UNLOCKED” (type B audio)/“The phonebook is unlocked.” (type C audio) will be displayed and the phonebook is unlocked.

▼ Phone setup



After selecting the “PHONE SETUP” menu, perform the following procedure.

▽ Pairing phone

Refer to “Preparation for using the Hands-free system” 5-53.

▽ Selecting phone

To select the registered cell phone for connecting to the in-vehicle equipment, perform the following procedure.



1. Select the “SELECT PHONE” menu.
 - If no cell phones are registered, “EMPTY” (type B audio)/“No Phones have been paired.” (type C audio) is displayed and the mode changes to the “PHONE SETUP” mode.
2. Select the cell phone by performing one of the following procedures.
 - Operate the “TUNE” dial.
 - Press the talk switch  and say the voice tag.
 - Press the talk switch  and use the list phones function (refer to “List phones function” 5-69.)
3. Select the “CONFIRM” (type B audio)/“Confirm Phone selection?” (type C audio) menu (only after saying the voice tag).
 - “SELECTED” (type B audio)/“Phone is selected.” (type C audio) is

displayed, the selected cell phone is connected to the in-vehicle equipment and the mode changes to the “PHONE SETUP” mode.

NOTE

For type B audio, if the cell phone cannot be connected to the in-vehicle equipment, “FAILED” is displayed and the mode changes to the “PHONE SETUP” mode.



▽ Changing the voice tag of the cell phone

1. Select the “CHANGE NAME” (type B audio)/“Change Phone Name” (type C audio) menu.
 - If no cell phones are registered, “EMPTY” (type B audio)/“No Phones have been paired.” (type C audio) is displayed and the mode changes to the “PHONE SETUP” mode.
2. Select the cell phone by performing one of the following procedures.
 - Operate the “TUNE” dial.
 - Press the talk switch  and say the voice tag.
 - Press the talk switch  and use the list phones function (refer to “List phones function” 5-69.)
3. Register the voice tag. For details,

refer to “Preparation for using the Hands-free system” 5-53.

▽ List phones function

The cell phone voice tags saved in the cell phone list are displayed by using the list phones function.

1. Select the “LIST PHONES” menu.
 - If no cell phones are registered, “EMPTY” (type B audio)/“No Phones have been paired.” (type C audio) is displayed and the mode changes to the “PHONE SETUP” mode.
2. Registered cell phones are displayed in the saved order. While displayed, if the “TUNE” dial is turned, the next registered cell phone is displayed. Press the ON hook button  to close the Hands-free menu.
3. Select a cell phone by performing either of the following procedures.
 - Operate the “TUNE” dial.
 - Press the talk switch .
4. After “SELECTED” (type B audio)/“Phone is selected.” (type C audio) is displayed, you can select the following menus.
 - “SELECT PHONE” to connect the selected cell phone
 - “CHANGE NAME” (type B audio)/

“Change Phone Name” (type C audio) to change the voice tag

- “DELETE” (type B audio)/“Delete Phone” (type C audio) to delete the selected cell phone from the list
- “GO BACK” to go back to the “PHONE SETUP” mode



▽ Setting passkey

1. Select the “SET PASSKEY” menu.
 - After the currently set passkey is displayed, a new passkey can be entered.
2. Input the new passkey by performing one of the following procedures.
 - Operate the “TUNE” dial.
 - Press the talk switch  and say the passkey.
3. Select the “CONFIRM” (type B audio)/“Confirm passkey?” (type C audio) menu.
 - The new passkey is displayed, the passkey is changed and the mode changes to the “PHONE SETUP” mode.

▽ Deleting registered cell phone from the list

1. Select the “DELETE” (type B audio)/“Delete Phone” (type C audio) menu.
2. Select a cell phone to be deleted by performing one of the following proce-

dures.

- Operate the “TUNE” dial.
 - Press the talk switch  and say the voice tag.
 - Press the talk switch  and use the list phones function.
3. Select the “CONFIRM” (type B audio)/“Confirm delete phone?” (type C audio) menu.

- “DELETED” (type B audio)/“Phone has been deleted.” (type C audio) is displayed, the data is deleted and the mode changes to the “PHONE SETUP” mode.

▽ Turning the Hands-free power on/off (type C audio)

You can turn the Hands-free power on or off. If the Hands-free power is ON, the registered cell phones are automatically connected to the system when the ignition switch is turned to the “Acc” or “ON” position.

1. Select the “Hands-free Power”/“Handsfree Power” menu.
2. To turn off the Hands-free power when the Hands-free power is ON, perform either of the following procedures.
 - Press the talk switch  and say “Turn off”.
 - Select “Turn off” by operating the

“TUNE” dial.

To turn on the Hands-free power when the Hands-free power is OFF, perform either of the following procedures.

- Press the talk switch  and say “Turn on”.
- Select “Turn on” by operating the “TUNE” dial.

▼ System setup

After selecting the “SYSTEM SETUP” menu, perform the following procedure. You can select the following menus only by operating the “TUNE” dial.

▽ Setting guidance volume

To set the guidance volume, perform the following procedure.

1. Select the “GUIDANCE VOL” (type B audio)/“Guidance Volume” (type C audio) menu.
2. Set the guidance volume by operating the “TUNE” dial.

▽ Initializing the registered data

To initialize the registered data, perform the following procedure.

1. Select the “INITIALIZE” (type B audio)/“Reset Settings” (type C audio) menu.
2. Select the “CONFIRM” (type B audio)/

“Confirm reset settings?” (type C audio) menu.

- “INITIALIZED” (type B audio)/“Settings have been reset.” (type C audio) is displayed, the registered data is initialized and the mode changes to the last mode.

▽ Selecting language

To select the language, perform the following procedure.

Type B audio:

1. Select the “SEL LANGUAGE” menu.
2. Select the desired language by operating the “TUNE” dial.

Type C audio:

“HD/TEXT” button	
------------------	---

1. Press and hold the “HD/TEXT” button to select “Select Langu” menu.
2. Select the preferred language by operating the “TUNE” dial.

▽ Device name function (type C audio)

Select the “Device Name” menu to show the device name and BD address of the audio.

Interior light	6-2	Ashtray (if equipped)	6-12
Dome light	6-2	Coat hook	6-13
Map light.....	6-2	Shopping bag hook	6-13
Cargo area light (Outback).....	6-3	Legacy	6-13
Sun visors	6-4	Outback	6-14
Sun visor extension plate	6-4	Floor mat	6-14
Vanity mirror with light	6-5	Cargo area cover (Outback – if equipped)	6-15
Storage compartment	6-5	Using the cover	6-15
Glove box	6-6	To remove the cover housing.....	6-16
Center console box	6-6	Stowage of the cargo area cover	6-16
Overhead console	6-8	To install the cover housing	6-17
Pocket (if equipped)	6-8	Convenient tie-down hooks (Outback)	6-17
Cup holder	6-8	Under-floor storage compartment	6-18
Front passenger's cup holder	6-9	Rear view camera (if equipped)	6-19
Rear passenger's cup holder	6-9	How to use the rear view camera	6-20
Bottle holders	6-9	Viewing range on the screen	6-21
Accessory power outlets	6-10	Help line.....	6-22

Interior light

When leaving your vehicle, make sure the lights are turned off to avoid battery discharge.

■ Dome light

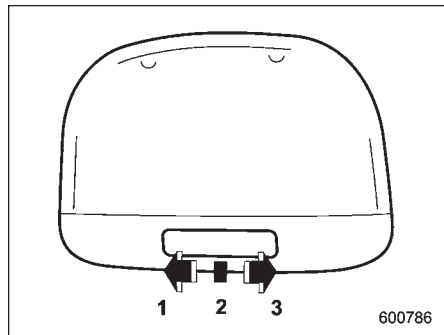

- 1) ON
- 2) DOOR
- 3) OFF

The dome light switch has three positions:

ON: The light remains on continuously.

OFF: The light remains off.

DOOR: The dome light illuminates automatically in the following cases.

- Any of the doors or the rear gate (Outback) is opened.

- The doors or the rear gate (Outback) are unlocked using the remote keyless entry transmitter.
- The ignition switch is turned from the "Acc" position to the "LOCK" position.

The automatically illuminated dome light remains on for several seconds and then gradually turns off after all doors and the rear gate (Outback) are closed. While the light is on, if any of the following operations are performed, the dome light turns off immediately.

- The ignition switch is turned from the "LOCK" position to "Acc" or "ON" position.
- All doors and the rear gate (Outback) are locked using the remote keyless entry transmitter.

The setting of the period for which the light remains on (OFF delay timer) can be changed by a SUBARU dealer. Contact your SUBARU dealer for details.

■ Map light

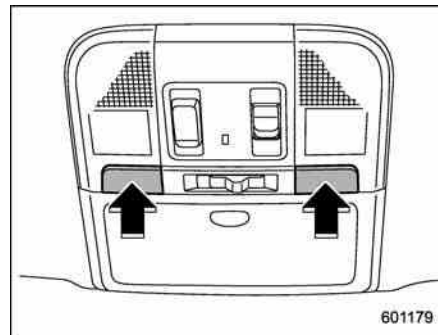

Models with moonroof

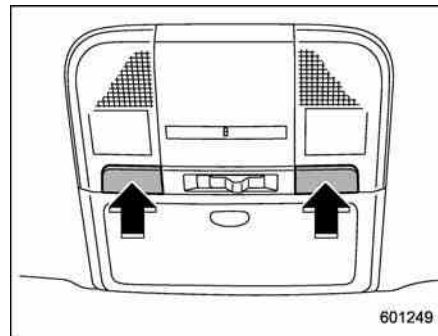

Models without moonroof

To turn on the map light, press the switch. To turn it off, press the switch again.

When leaving the vehicle, make sure the lights are turned off to avoid battery discharge.

▼ Door interlock switch

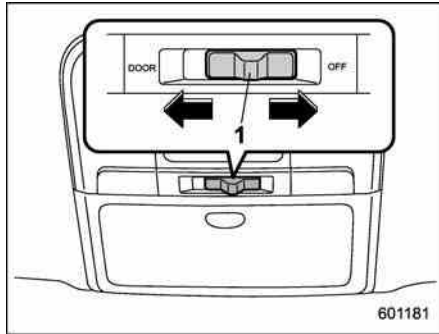

1) Door interlock switch

Although the map light switches are in the OFF position (manually off), the map lights can be set to illuminate automatically in conjunction with a door opening, etc. by use of the door interlock switch. The door interlock switch has the following positions.

OFF: The map lights do not illuminate automatically in conjunction with a door opening. But, the lights can be turned on manually by pressing the map light switches.

DOOR: The map lights illuminate automatically in the following cases.

- Any of the doors (other than the rear gate or trunk lid) is opened. The map lights do not illuminate when only the rear gate is opened.
- The doors are unlocked using the remote keyless entry transmitter.
- The ignition switch is turned from the "Acc" position to the "LOCK" position.

The automatically illuminated map lights remain on for several seconds and then gradually turn off after all doors are closed. While the lights are on, if any of the following operations are performed, the map lights turn off immediately.

- The ignition switch is turned from the "LOCK" position to the "Acc" or "ON" position.
- All doors are locked using the remote keyless entry transmitter.

The setting of the period for which the lights remain on (OFF delay timer) can be changed by a SUBARU dealer. Contact your SUBARU dealer for details.

■ Cargo area light (Outback)

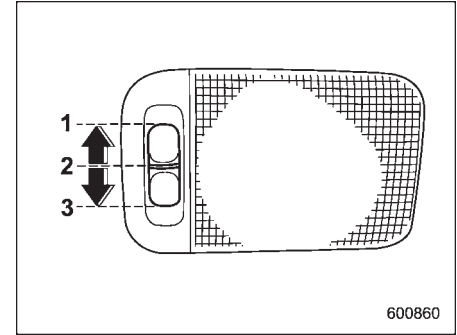

- 1) DOOR
- 2) OFF
- 3) ON

The cargo area light switch has the following positions.

DOOR: The light illuminates only when the rear gate is opened.

OFF: The light remains off.

ON: The light remains on continuously.

The automatically illuminated cargo area light remains on for several seconds and then gradually turns off after the rear gate is closed. While the light is on, if any of the following operations are performed, the cargo area light turns off immediately.

6-4 Interior equipment

- The ignition switch is turned from the “LOCK” position to the “Acc” or “ON” position.
- The rear gate is locked using the remote keyless entry transmitter.

The setting of the period for which the lights remain on (OFF delay timer) can be changed by a SUBARU dealer. Contact your SUBARU dealer for details.

Sun visors

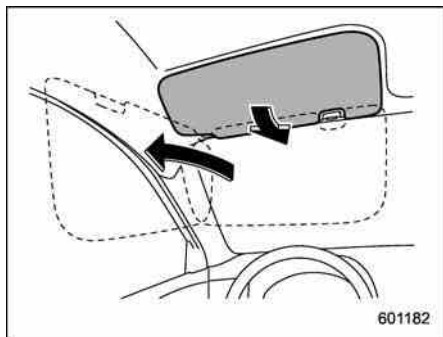

To block out glare, swing down the visors.
To use the sun visor at a side window, swing it down and move it sideways.

■ Sun visor extension plate

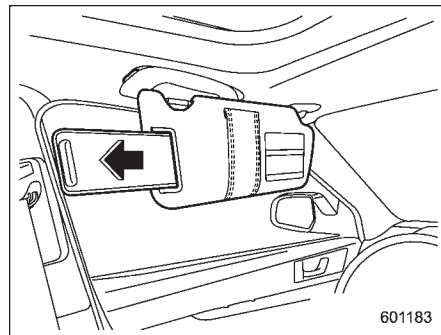

With the sun visor positioned over the side window, you can use the sun visor extension plate to prevent glare through the gap between the sun visor and center pillar. To use the extension plate, pull it toward the rear of the vehicle. When you have finished using it, stow it by pushing it toward the front of the vehicle.

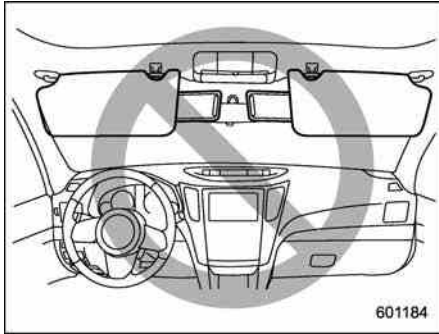

CAUTION

Do not pull out the extension plate with the sun visor positioned over the windshield. The extension plate would obstruct your view of the rearview mirror.

■ Vanity mirror with light

CAUTION

Keep the vanity mirror cover closed while the car is being driven to avoid being blinded by glare.

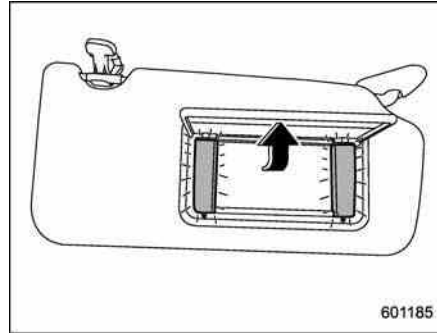

To use the vanity mirror, swing down the sun visor and open the vanity mirror cover. The lights beside the vanity mirror illuminate when the mirror cover is opened.

NOTE

Use of the vanity mirror light for a long period of time while the engine is not running can cause battery discharge.

Storage compartment

CAUTION

- Always keep the storage compartment closed while driving to reduce the risk of injury in the event of sudden stops or an accident.
- Do not store spray cans, containers with flammable or corrosive liquids or any other dangerous items in the storage compartment.

■ Glove box

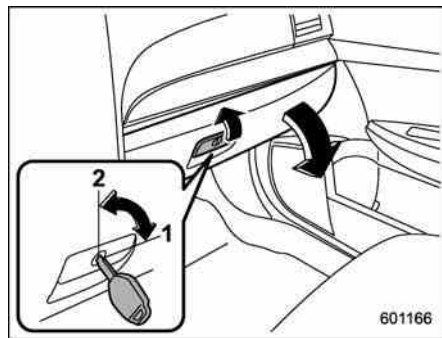

- 1) Lock
- 2) Unlock

To open the glove box, pull the handle. To close it, push the lid firmly upward.

To lock the glove box, insert the key and turn it clockwise. To unlock the glove box, insert the key and turn it counterclockwise.

■ Center console box

▼ Center console box (front)

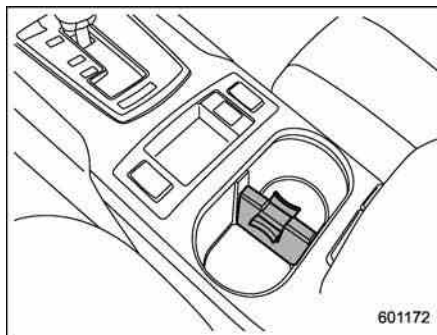

If you remove the divider plate from the dual cup holders, you can use the center console box as a storage space.

To use as storage space:

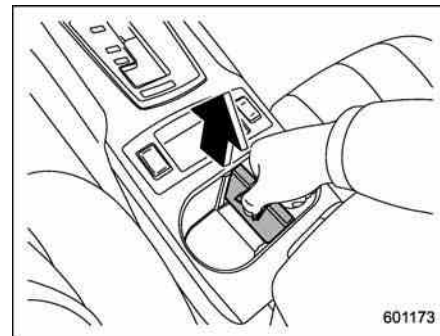

Pull out the divider plate of the dual cup holder.

To use again as cup holders:

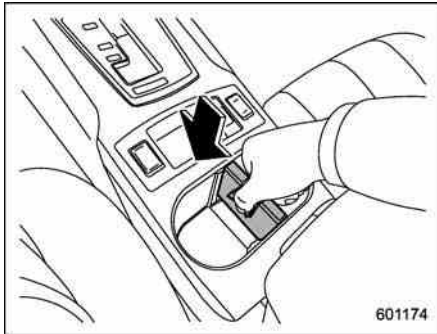

Insert the divider plate into the console box.

▼ Center console box (rear)

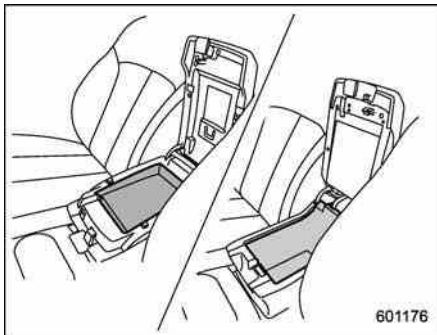

The center console box has a two-layer structure consisting of an upper compart-

ment and a lower compartment.

▽ Upper compartment

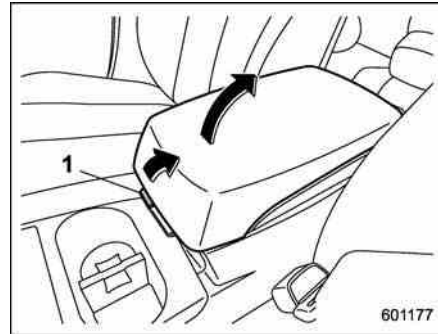

- 1) Upper compartment lock release

Pull up the upper compartment lock release to open the upper compartment.

▽ Lower compartment

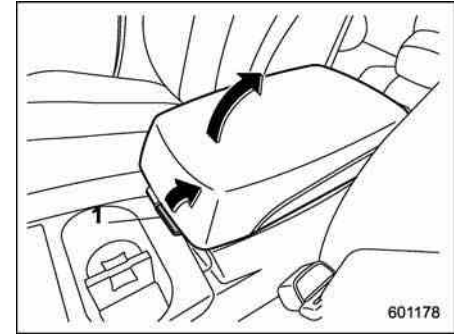

- 1) Lower compartment lock release

Pull up the lower compartment lock release to open the lower compartment.

Overhead console

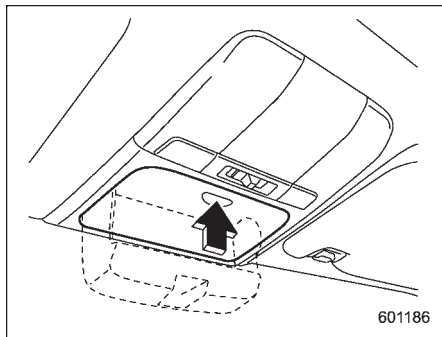

To open the console, push on the lid lightly and it will automatically open.

CAUTION

When your vehicle is parked in the sun or on a warm day, the inside of the overhead console heats up. Avoid storing plastic or other heat-vulnerable or flammable articles such as a lighter in the overhead console.

Pocket (if equipped)

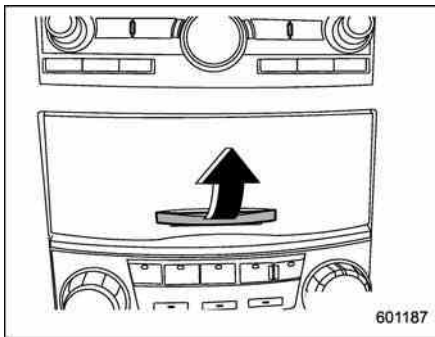

CAUTION

Do not use the pocket as an ashtray or leave a lighted cigarette in the pocket. This could cause a fire.

To use the pocket, open the lid.

Cup holder

CAUTION

- Do not pick up a cup from the cup holder or put a cup in the holder while you are driving, as this may distract you and lead to an accident.
- Take care to avoid spills. Beverages, if hot, might burn you or your passengers. Spilled beverages may also damage upholstery or carpets.

■ Front passenger's cup holder

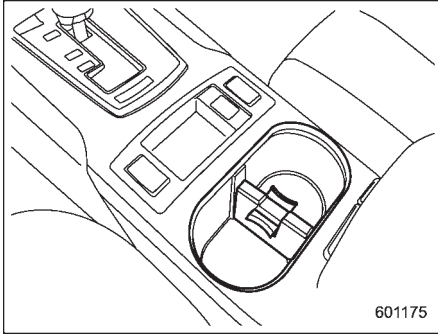

601175

The dual cup holder is built into the center console.

■ Rear passenger's cup holder



601188

A dual cup holder is built in the armrest.

⚠ CAUTION

When a cup containing a beverage is in the cup holder, do not fold down or recline any seat. Otherwise, the beverage could spill while driving and, if the beverage is hot, it could scald you.

Bottle holders

⚠ CAUTION

- Do not pick up a bottle from the bottle holder or put a bottle in the holder while you are driving, as this may distract you and lead to an accident.
- When placing a beverage in a door pocket, make sure it is capped. Otherwise, the beverage could spill when opening/closing the door or while driving and, if the beverage is hot, it could scald you.

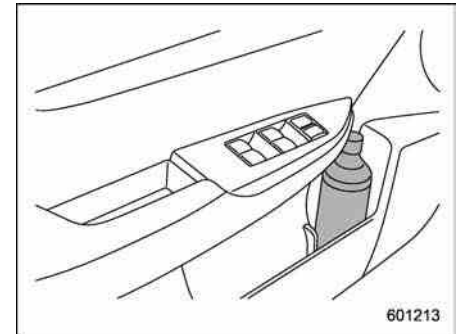

601213

The door pocket equipped on each door

6-10 Interior equipment

trim can be used to hold beverage bottles and other items.

Accessory power outlets

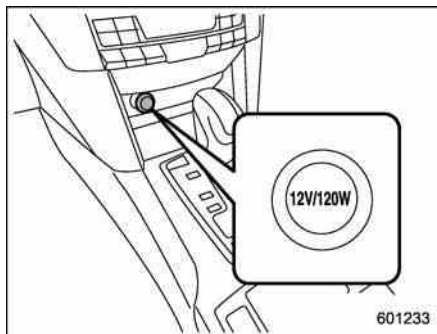

Power outlet below the climate control

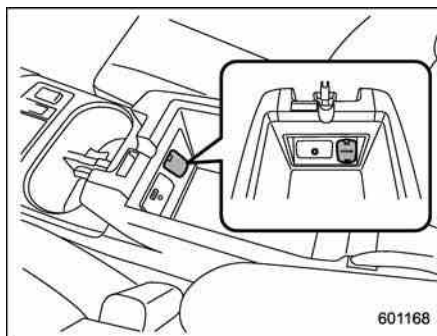

Power outlet in the center console

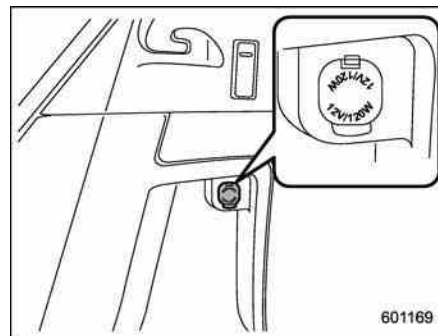

Power outlet in the cargo area (Outback)

Accessory power outlets are provided below the climate control, in the center console and in the cargo area. Electrical power (12V DC) from the battery is available at any of the outlets when the ignition switch is in either the "Acc" or "ON" position.

You can use an in-vehicle electrical appliance by connecting it to an outlet.

The maximum power rating of an appliance that can be connected is **120W**. Do not use an appliance which exceeds the indicated wattage for each outlet.

When using appliances connected to two or more outlets simultaneously, the total power consumed by them must not exceed 120W.

CAUTION

- Do not attempt to use a cigarette lighter in the accessory power outlet.
- Do not place any foreign objects, especially metal ones such as coins or aluminum foil, into the accessory power outlet. That could cause a short circuit. Always put the cap on the accessory power outlet when it is not in use.
- Use only electrical appliances which are designed for 12V DC.

The maximum power rating of an appliance that can be connected is 120W. Do not use an appliance which exceeds the indicated wattage for each outlet.

When using appliances connected to two or more outlets simultaneously, the total power consumed by them must not exceed 120W. Overloading the accessory power outlet can cause a short circuit. Do not use double adapters or more than one electrical appliance.

- If the plug on your electric appliance is either too loose or too

tight for the accessory power outlet, this can result in a poor contact or cause the plug to get stuck. Only use plugs that fit properly.

- Use of an electric appliance in the accessory power outlet for a long period of time while the engine is not running can cause battery discharge.
- Before driving your vehicle, make sure that the plug and the cord on your electrical appliance will not interfere with your shifting gears and operating the accelerator and brake pedals. If they do, do not use the electrical appliance while driving.

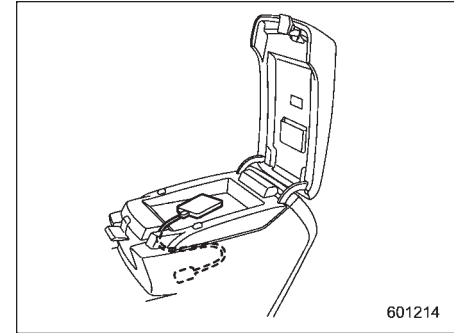

601214

Upper compartment

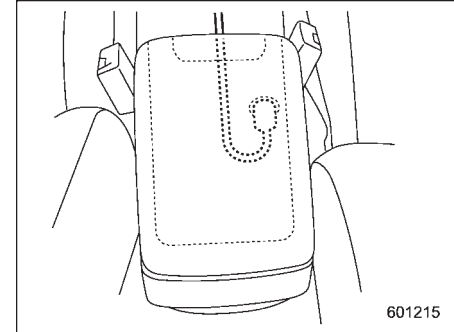

601215

Lower compartment

NOTE

When the lid of the center console is closed, a gap remains between the center console and the lid to allow the

power outlet in the center console to be used. Pass the cord of the electrical appliance through this gap.

Ashtray (if equipped)

 **CAUTION**

- Do not use ashtrays as waste receptacles or leave a lighted cigarette in an ashtray. This could cause a fire.
- Always extinguish matches and cigarettes before putting them into the ashtray, and then close the ashtray securely. If you keep the ashtray open, the fire of the cigarette may spread to another cigarette butt and start a fire.
- Do not put flammable material in the ashtray.
- Do not leave a lot of cigarette butts in the ashtray.

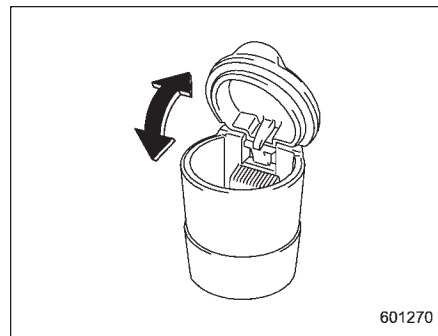

The portable ashtray can be installed in each cup holder. For the locations of the cup holders, refer to “Cup holder” ¶ 6-8. When using the ashtray, open the lid of the ashtray. When removing the ashtray from a cup holder, pull the ashtray upwards. Fully close the lid after using the ashtray to help reduce residual smoke.

NOTE

Particles of ash and tobacco will accumulate around the hinges of the ashtray’s inner lid. Clean them off using a toothbrush or another narrow-ended implement.

Coat hook

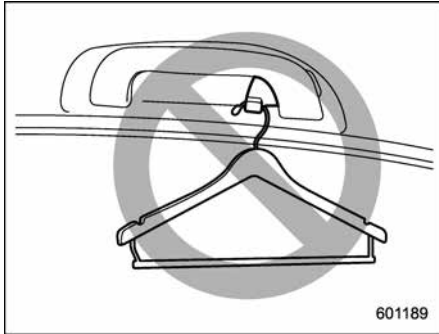

601189

! WARNING

Do not hang coat hangers or other hard or pointed objects on the coat hooks. If such items were hanging on the coat hooks during deployment of the SRS curtain airbags, they could cause serious injuries by coming off the coat hooks and being thrown through the cabin or by preventing correct airbag deployment. Before hanging clothing on the coat hooks, make sure there are no pointed objects in the pockets. Hang clothing directly on the coat hooks without using hangers.

! CAUTION

Never hang anything on the coat hook that might obstruct the driver's view or that could cause injury in sudden stops or in a collision. And do not hang items on the coat hook that weigh 11 lbs (5 kg) or more.

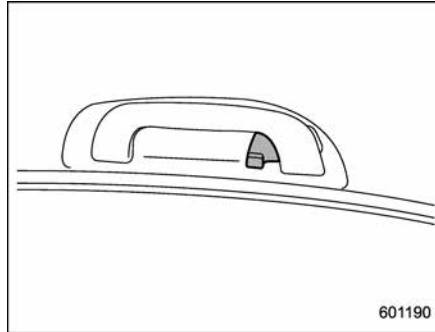

601190

The coat hook is attached to each rear passenger's hand grip.

Shopping bag hook

! CAUTION

Do not hang items on the shopping bag hook that weigh 11 lbs (5 kg) or more.

■ Legacy

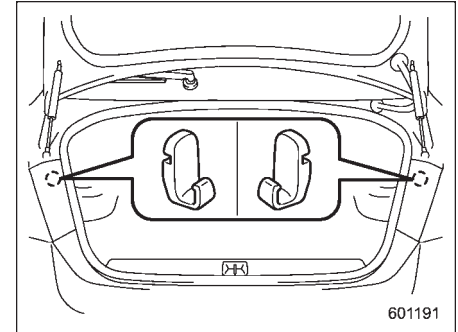

601191

A shopping bag hook is attached to each inner side wall of the trunk near the trunk lid opening.

■ Outback

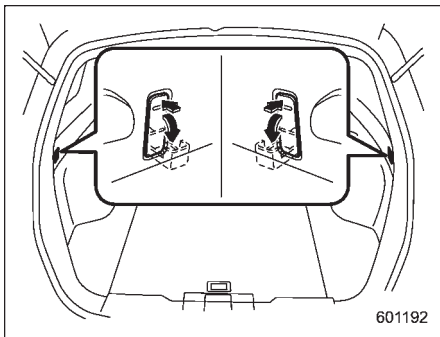

A shopping bag hook is attached to each side of the cargo area.

To use the hook, push the upper portion and the shopping bag hook will appear.

Floor mat

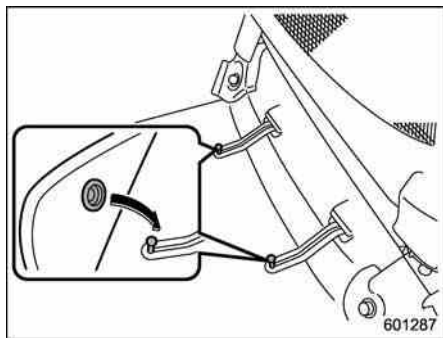

Retaining pins are located on the driver's side floor.

The floor mat should be properly secured using the built-in grommets, by placing the grommets over the pins and pushing them downward.

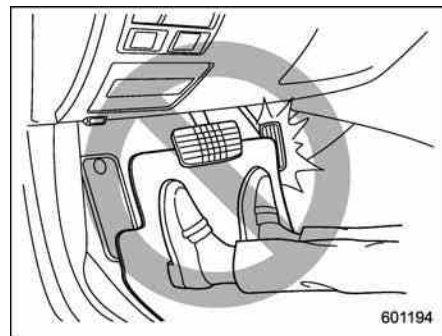

CAUTION

If the floor mat slips forward and interferes with the movement of the pedals during driving, it could cause an accident. Observe the following precautions to prevent the floor mat from slipping forward.

- Be sure to use a genuine SUBARU floor mat designed with grommets in the correct locations.
- Make sure that the driver's floor mat is placed back in its proper location and is correctly secured on its retaining pins.

- Do not use more than one floor mat.

Cargo area cover (Outback – if equipped)

The cargo area cover is provided for covering the cargo area and to protect its contents from direct sunlight. This cover is detachable to make room for additional cargo.

■ Using the cover

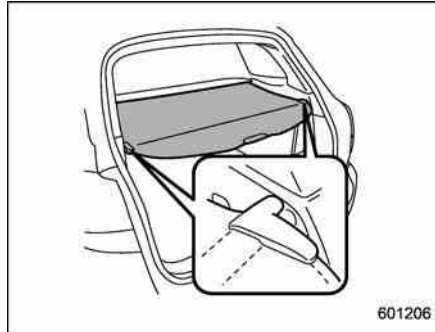

To extend the cover, pull the end of the cover out of the housing, then insert its hooks into the catches as shown. To rewind it, unhook it from the catches and it will rewind automatically. You should hold on to the cover and guide it back into the cover housing while it is rewinding.

WARNING

Do not place anything on the extended cover. Putting excessive weight on the extended cover can break it and an object on the cover could tumble forward in the event of a sudden stop or collision. This could cause serious injury.

CAUTION

- Be careful not to scratch the rear gate stays while extending and rewinding the cover. Scratches on the stays could cause leakage of gas from the stays, which may result in their inability to hold the rear gate open.
- When reclining the rear seatback, move the front cover backward so that the cover is not damaged.

■ To remove the cover housing

1. Rewind the cover.

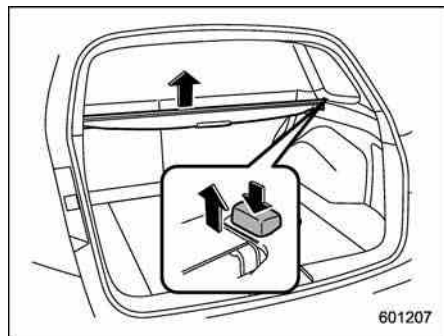

2. Hold down the button on the right-hand rear quarter panel and lift up the right-hand cover housing.
3. Remove the cover housing.

■ Stowage of the cargo area cover

The cargo area cover can be stowed in under the cargo floor.

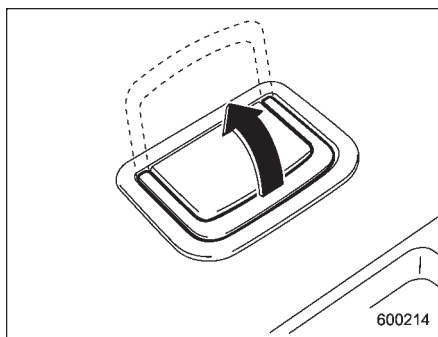

1. To open the lid, pull the handle up.

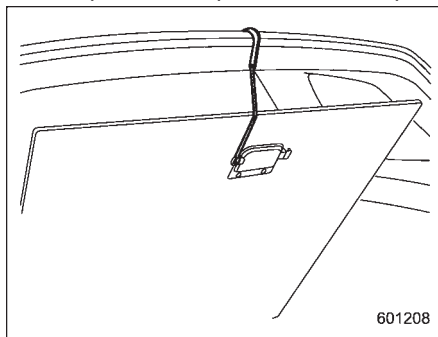

2. To keep the lid open, hang the hook (provided on the back of the lid) on the rear edge of the roof.

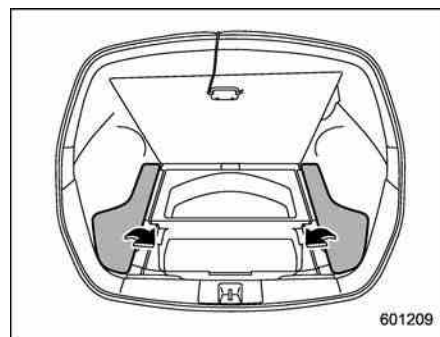

3. Remove the left and right parts of the cargo floor lid.

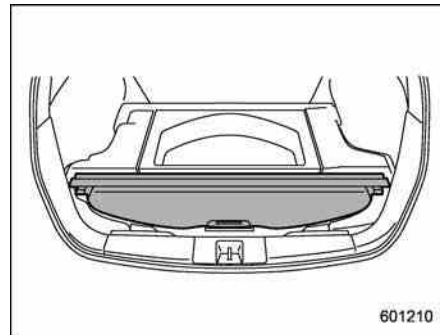

4. Stow the cover housing in the cargo area end.

■ To install the cover housing

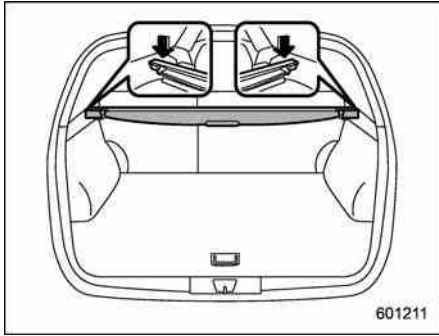

1. To install the cover housing, insert both ends of the cover housing into the retainers.

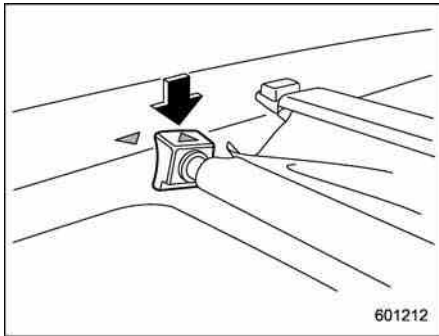

2. Make sure to fix the front part of the

cargo area cover behind the rear seat.

Convenient tie-down hooks (Outback)

CAUTION

The convenient tie-down hooks are designed only for securing light cargo that exceeds the capacity of the hooks. Never try to secure cargo that exceeds the capacity of the hooks. The maximum load capacity is 44 lbs (20 kg) per hook.

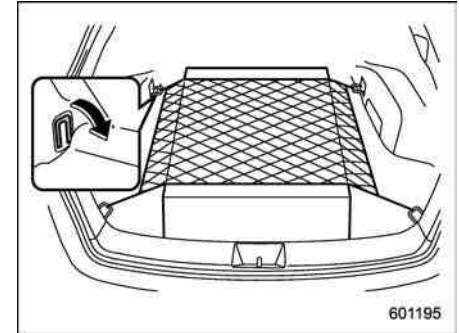

The cargo area is equipped with four tie-down hooks so that cargo can be secured with a luggage net or ropes.

When using the tie-down hooks, turn them down out of the storing recesses. When not in use, put the hooks up into the

storing recesses.

Under-floor storage compartment

The subfloor storage compartment is located under the floor of the trunk or cargo area and can be used to store small items. To open the lid, pull the tab or handle up.

NOTE

When storing a flat tire, put the sub-floor storage in the trunk or cargo area.



CAUTION

- Always keep the lid of the sub-floor storage compartment closed while driving to reduce the risk of injury in the event of sudden stop or an accident.
- Do not store spray cans, containers with flammable or corrosive liquids or any other dangerous items in the subfloor storage compartment.

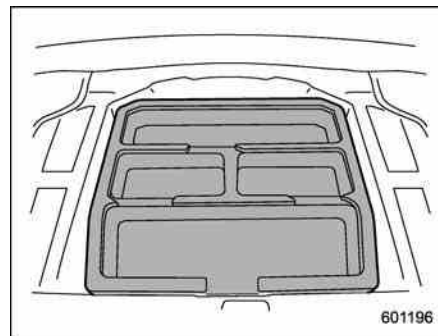

Legacy

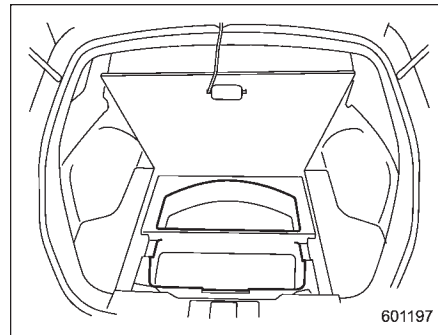

Outback

Hang the hook provided on the underside of the lid on the rear edge of the roof to keep the lid open.

Rear view camera (if equipped)

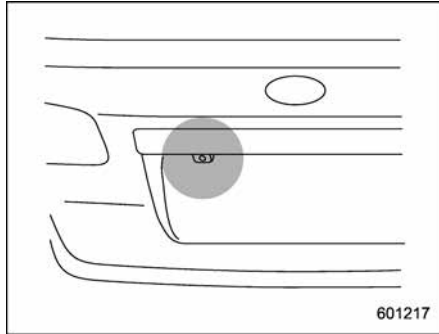

Legacy

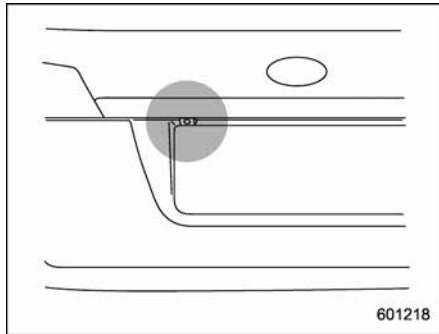

Outback

A rear view camera is attached to the trunk lid (Legacy) or rear gate (Outback). When the ignition switch is "ON" and the shift lever (MT models) or select lever (AT or CVT models) is set to "R", the rear view camera automatically displays the rear view image behind the vehicle on the audio/navigation monitor or on the inside mirror depending on the model.

WARNING

- Since the rear view camera uses a wide-angle lens, the image on the monitor is different from the actual view in terms of distance.
- Since the range of the image on the monitor is limited, you should always check the rear view and the surrounding area with your eyes and mirrors, and move backward at a slow speed. Moving backward only by checking the rear view image from the camera could cause an accident.
- Do not disassemble or modify the camera, switch or wiring. If smoke comes out or you smell a strange odor, stop using the rear view camera immediately. Contact your SUBARU dealer for an inspection. Continued use

may result in accident, fire or electric shock.

CAUTION

- If your vehicle is washed with a high-pressure washer, do not allow water to contact the camera directly. Entry of water in the camera lens may result in condensation, malfunction, fire or electric shock.
- Since the camera is a precision device, do not subject it to strong impacts. Otherwise, malfunction, fire or electric shock may occur.
- If mud or snow sticks to or is frozen on the camera, you must be very careful removing it. Otherwise, damage done to the camera may cause a fire or electric shock. Pour water or lukewarm water over the camera to remove mud and ice, and wipe it with a soft, dry cloth.
- Do not put a flame close to the camera or wiring. Otherwise, damage or fire may occur.
- When replacing the fuse, be sure to use a fuse with the specified rating. Use of a fuse with a

different rating may result in a malfunction.

- If the rear view camera is used for a long time while the engine is not operated, the battery may become completely discharged.

NOTE

- Do not wipe the camera with alcohol, benzene or paint thinner. Otherwise, discoloration may occur. To remove contamination, wipe the camera with a cloth moistened with a diluted neutral detergent and then wipe it with a soft, dry cloth.
- When waxing the vehicle, be careful not to apply the wax to the camera. If it comes in contact with the camera, moisten a clean cloth with a diluted neutral detergent to remove the wax.
- The camera lens has hard coating to help prevent scratches. However, when washing the vehicle or cleaning the camera lens, be careful not to scratch the camera lens. Do not use a washing brush directly on the camera lens. The monitor screen may be adversely affected.
- Strong light shined on the camera lens may develop white light stripes around the light source. This is not a

malfunction.

- Under fluorescent lighting, the display may flicker. However, this is not a malfunction.
- The image of the rear view camera may be slightly different from the actual color of the objects.

■ How to use the rear view camera

When the shift lever or select lever is set to "R", the rear view camera automatically displays the rear view image from the vehicle. When the lever is set to other positions, the image before setting to "R" is displayed.

1. Set the ignition switch to "ON".
2. Set the shift lever or select lever to "R".

NOTE

- For models with the genuine SUBARU navigation system, the image of the rear view camera has priority over other screen displays. To operate other screens, set the shift lever (MT models) or select lever (AT and CVT models) to a position other than "R".
- The image of the rear view camera is horizontally reversed as is the case with the vehicle rearview mirror or the side view mirror.

- It may be difficult to see the image of the rearview camera in the following cases. This is not a malfunction of the camera.

- The vehicle is in a dark place (at night, in a tunnel, etc.).
- The vehicle is in an extremely hot or cold place.
- An object (such as raindrops, snow, dirt, etc.) that disturbs the view of the rear view camera sticks to the lens of the camera.
- Strong light shined directly on the camera lens (occasionally, there are vertical lines on the screen).

■ Viewing range on the screen

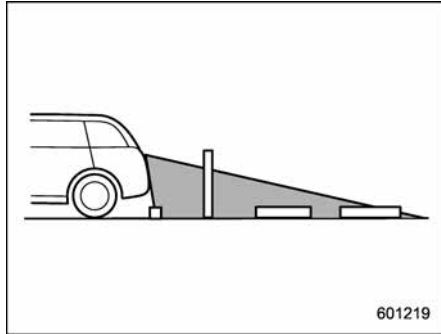

601219

Range of view

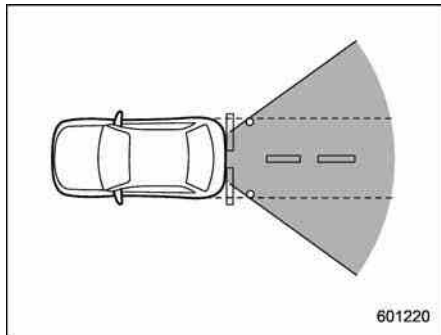

601220

Range of view

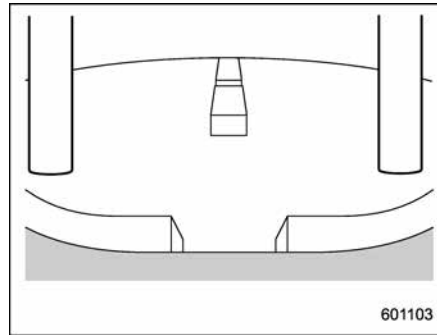

601103

Image from camera

The area from the rear end of the bumper can be viewed. Areas at both ends of the bumper and areas just under the bumper cannot be viewed.

Also, the image from the rear view camera looks shorter than the actual distance.



CAUTION

The range that can be viewed with the rear view camera is limited. Always be sure to check with your eyes when moving backward and proceed slowly.

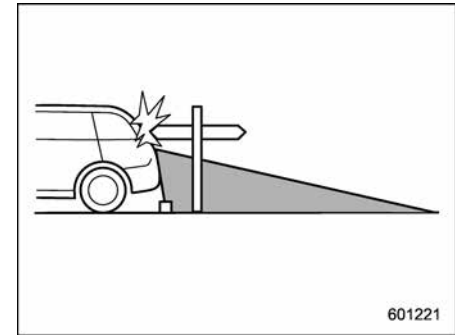

601221

Range of view

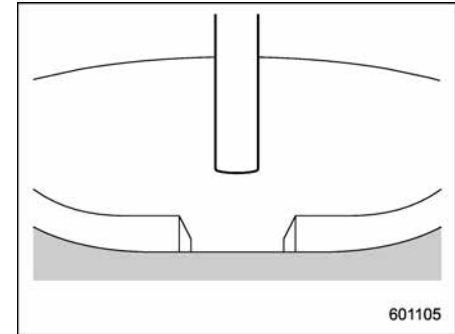

601105

Image from camera

The area above the camera cannot be viewed. If there is an object that has a wide projection on its upper part such as a sign pole behind the vehicle, the projec-

tion cannot be seen on the screen.

CAUTION

The range that can be viewed with the rear view camera is limited. Always be sure to check with your eyes when moving backward and proceed slowly.

Help line

The help line (distance marker and vehicle width line) is a guide to help you realize the actual distance from the screen.

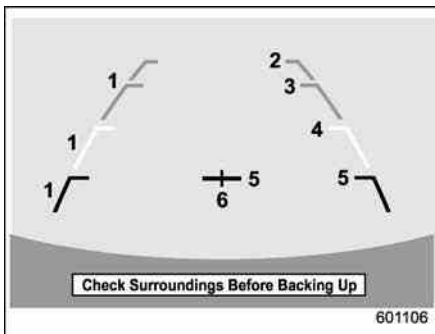

Help lines displayed on the navigation monitor

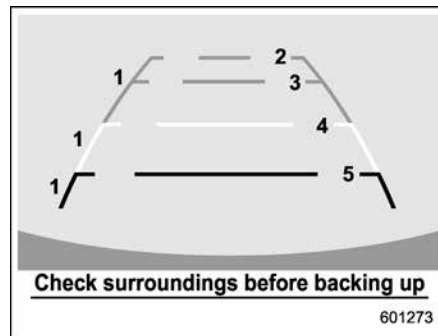

Help lines displayed on the inside mirror

- 1) Vehicle width line (oblique vertical line)
- 2) Approx. 10 feet (3 m) from the bumper (green horizontal line)
- 3) Approx. 6.5 feet (2 m) from the bumper (green horizontal line)
- 4) Approx. 3 feet (1 m) from the bumper (yellow horizontal line)
- 5) Approx. 1.5 feet (0.5 m) from the bumper (red horizontal line)
- 6) Vehicle centerline

When the shift lever or select lever is set to position "R", the monitor screen displays the help lines together with the rear view image.

CAUTION

- When moving backward, always check the back with your eyes

without relying on the help lines.

- The actual position may be different from the indication of the help lines.
- Differences may occur due to number of passengers or loaded cargo.
- When the vehicle is on a slope or when the vehicle is inclined against the road, the indication is different from the actual position.

▼ Difference between screen and actual road

The distance markers show the distance for a level road when the vehicle is not loaded. It may be different from the actual distance depending on the loading conditions or road conditions.

▽ When there is an upward slope at the back

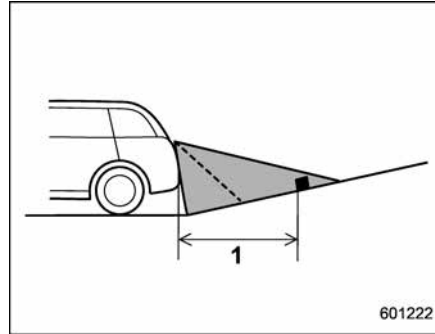

1) 3 feet (1 m)

The distance on the screen looks farther than the actual distance.

▽ When there is a downward slope at the back

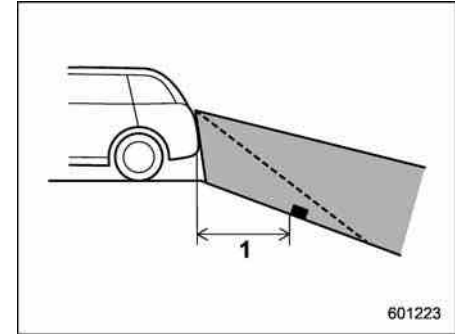

1) 3 feet (1 m)

The distance on the screen looks nearer than the actual distance.

NOTE

When cargo is loaded, the rear view distance on the screen looks farther than the actual distance as in an upward slope.

▼ Feature of distance marker

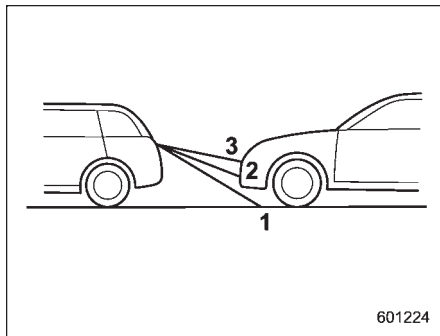

- 1) 3 feet (1 m) line
- 2) 6.5 feet (2 m) line
- 3) 10 feet (3 m) line

The distance marker shows the distance on the road. If there is a car or other object close behind, distance cannot be correctly displayed.

Fuel	7-2	Shift lock function	7-20
Fuel requirements	7-2	Selection of manual mode.....	7-21
Fuel filler lid and cap.....	7-3	Driving tips.....	7-22
State emission testing (U.S. only).....	7-6	Power steering.....	7-23
Preparing to drive	7-7	Braking	7-23
Starting the engine.....	7-8	Braking tips.....	7-23
MT models	7-8	Brake system	7-23
AT and CVT models.....	7-9	Disc brake pad wear warning indicators	7-24
Stopping the engine.....	7-10	ABS (Anti-lock Brake System).....	7-24
Remote engine start system (dealer option).....	7-10	ABS system self-check	7-25
Starting your vehicle	7-10	ABS warning light.....	7-25
Remote start safety features	7-11	Electronic Brake Force Distribution (EBD) system	7-25
Entering the vehicle while it is running via remote start.....	7-11	Steps to take if EBD system malfunctions	7-25
Remote start confirmation transmitter feature	7-12	Vehicle Dynamics Control system.....	7-26
Entering the vehicle following remote engine start shutdown.....	7-13	Vehicle Dynamics Control system monitor.....	7-28
Pre-heating or pre-cooling the interior of the vehicle	7-13	Vehicle Dynamics Control OFF switch	7-28
Service mode	7-13	Tire pressure monitoring system (TPMS) (if equipped)	7-29
Remote transmitter program	7-13	Parking your vehicle	7-30
System maintenance	7-14	Electronic parking brake	7-31
Manual transmission.....	7-15	Parking tips	7-34
Selecting reverse gear.....	7-16	Cruise control	7-35
Shifting speeds	7-16	To set cruise control	7-35
Driving tips	7-17	To temporarily cancel the cruise control.....	7-36
Automatic transmission/Continuously variable transmission	7-17	To turn off the cruise control.....	7-36
Select lever.....	7-18	To change the cruising speed	7-37
		Cruise control indicator light.....	7-38
		Cruise control set indicator light	7-38

Fuel



CAUTION

Use of a fuel which is low in quality or use of an inappropriate fuel additive may cause engine damage.

■ Fuel requirements

▼ Non-turbo models

The non-turbo engine is designed to operate using **unleaded** gasoline with an octane rating of **87 AKI (90 RON) or higher**.

▼ Turbo models

The engine is designed to operate at maximum performance using **premium unleaded** gasoline with an octane rating of **93 AKI (98 RON) or higher**. If 93 AKI (98 RON) fuel is not readily available in your area, unleaded gasoline with an octane rating of 91 AKI (95 RON) may be used with no detriment to engine durability or driveability. However, you may notice a slight decrease in maximum engine performance while using 91 AKI (95 RON) fuel. Use of 91 AKI (95 RON) fuel will not affect your warranty coverage. If premium unleaded gasoline is not

available, regular unleaded gasoline with an octane rating of 87 AKI (90 RON) or higher may be temporarily used. For optimum engine performance and driveability, it is required that you use premium grade unleaded gasoline.

NOTE

Be sure to use premium unleaded gasoline of 91 AKI (95 RON) or higher for a turbo engine model. If other gasoline (lower than 91 AKI (95 RON)) is used, knocking, reduced output and poor accelerator response will result.

▼ Fuel octane rating

This octane rating is the average of the Research Octane and Motor Octane numbers and is commonly referred to as the Anti Knock Index (AKI).

Using a gasoline with a lower octane rating can cause persistent and heavy knocking, which can damage the engine. Do not be concerned if your vehicle sometimes knocks lightly when you drive up a hill or when you accelerate. See your dealer or a qualified service technician if you use a fuel with the specified octane rating and your vehicle knocks heavily or persistently.

▼ Unleaded gasoline

The neck of the fuel filler pipe is designed to accept only an unleaded gasoline filler nozzle. Under no circumstances should leaded gasoline be used because it will damage the emission control system and may impair driveability and fuel economy.

▼ California fuel

If your vehicle was certified to California Emission Standards as indicated on the underhood tune-up label, it is designed to optimize engine and emission control system performance with gasoline that meets the clean burning low-sulfur California gasoline specifications. If you live in any other state than California, your vehicle will operate on gasoline meeting Federal specifications. Gasoline sold outside California is permitted to have higher sulfur levels, which may affect the performance of your vehicle's catalytic converter and may produce a sulfur exhaust odor or smell. SUBARU recommends that you try a different brand of unleaded gasoline having lower sulfur to determine if the problem is fuel related before returning your vehicle to an authorized dealer for service. The CHECK ENGINE warning light/malfunction indicator light may also turn on. If this occurs, return to your authorized SUBARU dealer for diagnosis. If it is determined that the condition is

caused by the type of fuel used, repairs may not be covered by your warranty.

▼ MMT

Some gasoline contains an octane-enhancing additive called MMT (Methylcyclopentadienyl Manganese Tricarbonyl). If you use such fuels, your emission control system performance may deteriorate and the CHECK ENGINE warning light/malfunction indicator light may turn on. If this happens, return to your authorized SUBARU Dealer for service. If it is determined that the condition is caused by the type of fuel used, repairs may not be covered by your warranty.

▼ Gasoline for cleaner air



CAUTION

Do not let fuel spill on the exterior surfaces of the vehicle. Fuels containing alcohol may cause paint damage, which is not covered under the SUBARU Limited Warranty.

Your use of gasoline with detergent additives will help prevent deposits from forming in your engine and fuel system. This helps keep your engine in tune and your emission control system working properly, and is a way of doing your part for cleaner air. If you continuously use a

high quality fuel with the proper detergent and other additives, you should never need to add any fuel system cleaning agents to your fuel tank.

Many gasolines are now blended with materials called oxygenates. Use of these fuels can also help keep the air cleaner. Oxygenated blend fuels, such as MTBE (Methyl Tertiary Butyl ether) or ethanol (ethyl or grain alcohol) may be used in your vehicle, but should contain no more than 15% MTBE or 10% ethanol for the proper operation of your SUBARU.

In addition, some gasoline suppliers are now producing reformulated gasolines, which are designed to reduce vehicle emissions. SUBARU approves the use of reformulated gasoline.

If you are not sure what the fuel contains, you should ask your service station operators if their gasolines contain detergents and oxygenates and if they have been reformulated to reduce vehicle emissions.

As additional guidance, only use fuels suited for your vehicle as explained in the following.

- Fuel should be unleaded and have an octane rating no lower than that specified in this manual.

- Methanol (methyl or wood alcohol) is sometimes mixed with unleaded gasoline. Methanol can be used in your vehicle **ONLY** if it does not exceed 5% of the fuel mixture **AND** if it is accompanied by sufficient quantities of the proper cosolvents and corrosion inhibitors required to prevent damage to the fuel system. Do not use fuel containing methanol **EXCEPT** under these conditions.

- If undesirable driveability problems are experienced and you suspect they may be fuel related, try a different brand of gasoline before seeking service at your SUBARU dealer.

- Fuel system damage or driveability problems which result from the use of improper fuel are not covered under the SUBARU Limited Warranty.

■ Fuel filler lid and cap

▼ Refueling

Only one person should be involved in refueling. Do not allow others to approach the area of the vehicle near the fuel filler pipe while refueling is in progress.

Be sure to observe any other precautions that are posted at the service station.

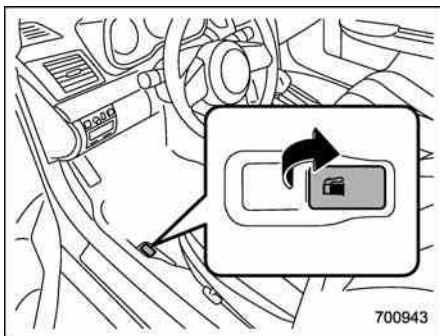

1. To open the fuel filler lid, pull the lid release lever up. The lever is on the floor at the left of the driver's seat.

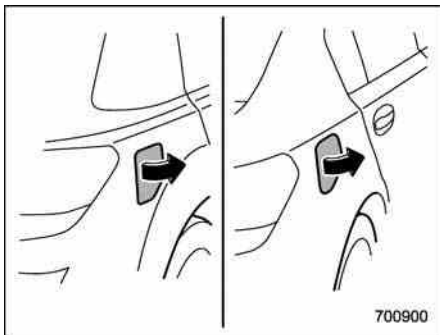

2. Open the fuel filler lid.

WARNING

Before opening the fuel filler cap, first touch the vehicle body or a metal portion of the fuel pump or similar object to discharge any static electricity that may be present on your body. If your body is carrying an electrostatic charge, there is a possibility that an electric spark could ignite the fuel, which could burn you. To avoid acquiring a new static electric charge, do not get back into the vehicle while refueling is in progress.

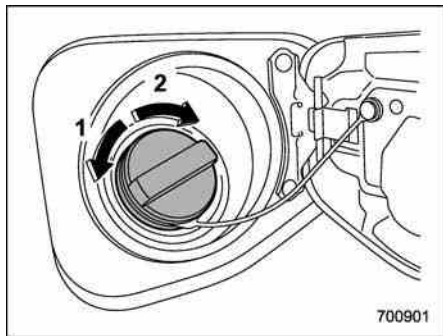

- 1) Open
- 2) Close

3. Remove the fuel filler cap by turning it

slowly counterclockwise.

WARNING

- Gasoline vapor is highly flammable. Before refueling, always first stop the engine and close all vehicle doors and windows. Make sure that there are no lighted cigarettes, open flames or electrical sparks in the adjacent area. Refueling must be performed outside. Quickly wipe up any spilled fuel.
- When opening the cap, grasp it firmly and turn it slowly to the left. Do not remove the cap quickly. Fuel may be under pressure and spray out of the fuel filler neck, especially in hot weather. If you hear a hissing sound while you are removing the cap, wait for the sound to stop and then slowly open the cap to prevent fuel from spraying out and creating a fire hazard.

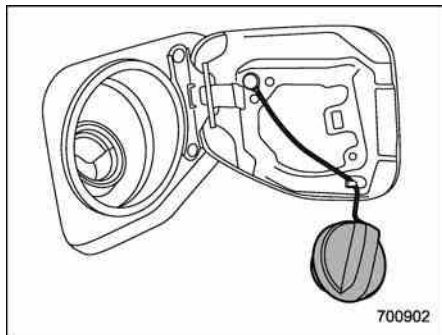

4. Hook the cord that is attached to the fuel filler cap onto the hook inside the fuel filler lid.

WARNING

- When refueling, insert the fuel nozzle securely into the fuel filler pipe. If the nozzle is lifted or not fully inserted, its automatic stopping mechanism may not function, causing fuel to overflow the tank and creating a fire hazard.
- Stop refueling when the automatic stop mechanism on the fuel nozzle activates. If you continue to add fuel, temperature changes or other conditions may cause fuel to overflow from

the tank and create a fire hazard.

5. Stop filling the tank after the fuel filler pump automatically turns off. Do not add any more fuel.

CAUTION

Make sure that the cap is tightened until it clicks to prevent fuel spillage in the event of an accident.



6. Put the cap back on, turn it clockwise until you hear a clicking noise. Be certain not to catch the tether under the cap while tightening.

7. Close the fuel filler lid completely. If you spill any fuel on the painted surface, rinse it off immediately. Otherwise, the painted surface could be damaged.

NOTE



200253

- You will see the “” sign in the fuel gauge. This indicates that the fuel filler door (lid) is located on the right side of the vehicle.
- If the fuel filler cap is not tightened until it clicks or if the tether is caught under the cap, the CHECK ENGINE warning light/malfunction indicator light may illuminate. Refer to “CHECK ENGINE warning light/Malfunction indicator light”  3-12.

CAUTION

- Never add any cleaning agents to the fuel tank. The addition of a cleaning agent may cause da-

mage to the fuel system.

- After refueling, turn the cap to the right until it clicks to ensure that it is fully tightened. If the cap is not securely tightened, fuel may leak out while the vehicle is being driven or fuel spillage could occur in the event of an accident, creating a fire hazard.
- Do not let fuel spill on the exterior surfaces of the vehicle. Because fuel may damage the paint, be sure to wipe off any spilled fuel quickly. Paint damage caused by spilled fuel is not covered under the SUBARU Limited Warranty.
- Always use a genuine SUBARU fuel filler cap. If you use the wrong cap, it may not fit, and your fuel tank and emission control system may be damaged. It could also lead to fuel spillage and a fire.
- Immediately put fuel in the tank whenever the low fuel warning light illuminates. Engine misfires as a result of an empty tank could cause damage to the engine.

State emission testing (U.S. only)

WARNING

Testing of an All-Wheel Drive model must NEVER be performed on a single two-wheel dynamometer. Attempting to do so will result in uncontrolled vehicle movement and may cause an accident or injuries to persons nearby.

CAUTION

- At state inspection time, remember to tell your inspection or service station in advance not to place your SUBARU AWD vehicle on a two-wheel dynamometer. Otherwise, serious transmission damage will result.
- Resultant vehicle damage due to improper testing is not covered under the SUBARU Limited Warranty and is the responsibility of the state inspection program or its contractors or licensees.

California and a number of federal states have Inspection/Maintenance programs to

inspect your vehicle's emission control system. If your vehicle does not pass this test, some states may deny renewal of your vehicle's registration.

Your vehicle is equipped with a computer that monitors the performance of the engine's emission control system. Certified emission inspectors will inspect the On-Board Diagnostic (OBDII) system as part of the state emission inspection process. The OBDII system is designed to detect engine and transmission problems that might cause the vehicle emissions to exceed allowable limits. OBDII inspections apply to all 1996 model year and newer passenger cars and trucks. Over 30 states plus the District of Columbia have implemented emission inspection of the OBDII system.

- The inspection of the OBDII system consists of a visual operational check of the "CHECK ENGINE" warning light/malfunction indicator light (MIL) and an examination of the OBDII system with an electronic scan tool.
- A vehicle passes the OBDII system inspection if proper operation of the "CHECK ENGINE" warning light is observed, there are no stored diagnostic trouble codes, and the OBDII readiness monitors are all complete.

- A vehicle fails the OBDII inspection if the “**CHECK ENGINE**” warning light is not properly operating (light is illuminated or is not working due to a burned out bulb) or there is one or more diagnostic trouble codes stored in the vehicle’s computer.
- A state emission inspection may reject (not pass or fail) a vehicle if the number of OBDII system readiness monitors “**NOT READY**” is greater than one. If the vehicle’s battery has been recently replaced or disconnected, the OBDII system inspection may indicate that the vehicle is not ready for the emission test. Under this condition, the vehicle driver should be instructed to drive his/her vehicle for a few days to reset the readiness monitors and return for an emission re-inspection.
- Owners of rejected or failing vehicles should contact their SUBARU Dealer for service.

Some states still use dynamometers in their emission inspection program. A dynamometer is a treadmill or roller-like testing device that allows your vehicle’s wheels to turn while the vehicle remains in one place. Prior to your vehicle being put on a dynamometer, tell your emission inspector not to place your SUBARU AWD vehicle on a two-wheel dynamometer. **Otherwise, serious transmission damage will result.**

The U.S. Environmental Protection Agency (EPA) and states using two-wheel dynamometers in their emission testing program have EXEMPTED SUBARU AWD vehicles from the portion of the testing program that involves a two-wheel dynamometer. There are some states that use four-wheel dynamometers in their testing program. When properly used, this equipment should not damage a SUBARU AWD vehicle.

Under no circumstances should the rear wheels be jacked off the ground, nor should the driveshaft be disconnected for state emission testing.

Preparing to drive

You should perform the following checks and adjustments every day before you start driving.

1. Check that all windows, mirrors, and lights are clean and unobstructed.
2. Check the appearance and condition of the tires. Also check tires for proper inflation.
3. Look under the vehicle for any sign of leaks.
4. Check that the hood, trunk (Legacy) and rear gate (Outback) are fully closed.
5. Check the adjustment of the seat.
6. Check the adjustment of the inside and outside mirrors.
7. Fasten your seatbelt. Check that your passengers have fastened their seatbelts.
8. Check the operation of the warning and indicator lights when the ignition switch is turned to the “ON” position.
9. Check the gauges, indicator and warning lights after starting the engine.

NOTE

Engine oil, engine coolant, brake fluid, washer fluid and other fluid levels should be checked daily, weekly or at fuel stops.

Starting the engine



Do not operate the starter motor continuously for more than 10 seconds. If the engine fails to start after operating the starter for 5 to 10 seconds, wait for 10 seconds or more before trying again.

■ MT models

1. Apply the parking brake.
 2. Turn off unnecessary lights and accessories.
 3. Depress the clutch pedal to the floor and shift the shift lever into neutral. Hold the clutch pedal to the floor while starting the engine. The starter motor will only operate when the clutch pedal is depressed fully to the floor.
 4. Turn the ignition switch to the "ON" position and check the operation of the warning and indicator lights. Refer to "Warning and indicator lights" 3-9.
 5. Turn the ignition switch to the "START" position **without** depressing the accelerator pedal. Release the key immediately after the engine has started.
- If the engine does not start, perform the

following procedure.

(1) Turn the ignition switch to the "LOCK" position and wait for at least 10 seconds. After checking that the parking brake is applied, turn the ignition switch to the "START" position while depressing the accelerator pedal slightly (approximately a quarter of the full stroke). Release the accelerator pedal as soon as the engine starts.

(2) If this fails to start the engine, turn the ignition switch back to the "LOCK" position and wait for at least 10 seconds. Then fully depress the accelerator pedal and turn the ignition switch to the "START" position. If the engine starts, quickly release the accelerator pedal.

(3) If this does not start the engine, turn the ignition switch again to the "LOCK" position. After waiting for 10 seconds or longer, turn the ignition switch to the "START" position without depressing the accelerator pedal.

(4) If the engine still refuses to start, contact your nearest SUBARU dealer for assistance.

6. Confirm that all warning and indicator lights have turned off after the engine has started. The fuel injection system automatically lowers the idle speed as the engine warms up.

NOTE (2.5 L non-turbo models)

To protect the engine while the shift lever is in the neutral position, the engine is controlled so that the engine speed may not become too high even if the accelerator pedal is depressed hard.

■ AT and CVT models



CAUTION

If you restart the engine while the vehicle is moving, shift the select lever into the “N” position. Do not attempt to place the select lever of a moving vehicle into the “P” position.

1. Apply the parking brake.
2. Turn off unnecessary lights and accessories.
3. Shift the select lever to the “P” or “N” position (preferably “P” position). The starter will only operate when the select lever is at the “P” or “N” position.

4. Turn the ignition switch to the “ON” position and check the operation of the warning and indicator lights. Refer to “Warning and indicator lights” 3-9.

5. Turn the ignition switch to the “START” position **without** depressing the accelerator pedal. Release the key immediately after the engine has started.

If the engine does not start, perform the following procedure.

(1) Turn the ignition switch to the “LOCK” position and wait for at least 10 seconds. After checking that the parking brake is applied, turn the ignition switch to the “START” position while depressing the accelerator pedal slightly (approximately a quarter of the full stroke). Release the accelerator pedal as soon as the engine starts.

(2) If this fails to start the engine, turn the ignition switch back to the “LOCK” position and wait for at least 10 seconds. Then fully depress the accelerator pedal and turn the ignition switch to the “START” position. If the engine starts, quickly release the accelerator pedal.

(3) If this fails to start the engine, turn the ignition switch again to the “LOCK” position. After waiting for 10 seconds or longer, turn the ignition switch to the “START” position without depressing

the accelerator pedal.

(4) If the engine still refuses to start, contact your nearest SUBARU dealer for assistance.

6. Confirm that all warning and indicator lights have turned off after the engine has started. The fuel injection system automatically lowers the idle speed as the engine warms up.

While the engine is warming up, make sure that the select lever is at the “P” or “N” position and that the parking brake is applied.

NOTE (2.5 L non-turbo and 3.6 L models)

To protect the engine while the select lever is in the “P” or “N” position, the engine is controlled so that the engine speed may not become too high even if the accelerator pedal is depressed hard.

Stopping the engine

 **WARNING**

Do not stop the engine when the vehicle is moving. This will cause loss of power to the power steering and the brake booster, making steering and braking more difficult. It could also result in accidental activation of the “LOCK” position on the ignition switch, causing the steering wheel to lock.

The ignition switch should be turned off only when the vehicle is stopped and the engine is idling.

Remote engine start system (dealer option)

 **WARNING**

- Do not remote start a vehicle in an enclosed environment (e.g. closed garage). Prolonged operation of a motor vehicle in an enclosed environment can cause a harmful build-up of Carbon Monoxide. Carbon Monoxide is harmful to your health. Exposure to high levels of Carbon Monoxide can cause headaches, dizziness or in extreme cases unconsciousness and/or death.
- Before performing any servicing of the vehicle, temporarily place the remote engine start system in service mode to prevent the system from unexpectedly starting the engine.

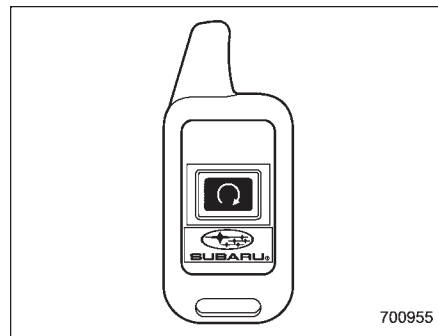

■ Starting your vehicle

NOTE

All vehicle doors, the engine hood and trunk / rear gate must be closed prior to activating the remote engine start system. Any open entry point will prevent starting or cause the system to shut down.

The remote engine start function is activated by pressing the “Q” button twice within 3 seconds on your remote engine start transmitter. Upon successful activation the remote start confirming transmitter button will flash once* and the vehicle will honk the horn and flash the side marker lights, tail lights and front position lights once. The system will check certain

preconditions before starting, and if all safety parameters are correct, the engine will start within 5 seconds. Upon successful engine start, the remote start confirmation transmitter button will flash twice every 5 seconds* and the vehicle will honk the horn and flash the side marker lights, tail lights and the front position lights once, then the lights will illuminate and remain illuminated, indicating that the engine is running. While the vehicle is operating via the remote engine start function, the power window features will be disabled. Also, the system has a timer and will shut down after 15 minutes if you do not operate the vehicle. Press and hold the "Ⓞ" button for 2 seconds to turn the engine off. The remote start confirmation transmitter button will flash three times* indicating that the engine has shut down. If the starter cranks but does not start or starts and stalls, the remote engine start system will power off and then attempt to start the engine an additional three times unless the remote engine start system determines that a vehicle malfunction is preventing the system from starting. If the engine does not start after additional attempts, the remote engine start system will abort and return to a non-activate state.

*: Provided that the remote engine start

transmitter is within the operating range of the system.

■ Remote start safety features

For safety and security reasons, the system will fail to start and honk the horn twice or shut down the engine during remote start operation if any of the following occur:

- Any of the doors or the trunk / rear gate are open / opened (*the vehicle's horn will honk six times and the side marker lights, tail lights and the front position lights will flash six times indicating that a vehicle door or trunk / rear gate was open when the remote engine start system was activated).
- The brake pedal is depressed
- The key was already in the ignition switch
- The engine hood is opened
- The remote start system "Service mode" is engaged
- The vehicle's engine idle speed has reached a level over 3,500 RPM
- The alarm is triggered by opening a door or the rear gate.
- The select lever is not in the "P" position (AT and CVT models)

In addition to the items above, if the

vehicle's engine management system determines there is a safety risk due to a vehicle related problem, the vehicle will shut down and the vehicle's horn will honk three times.

NOTE

- **If the alarm system is armed at the time of remote engine start activation (the security indicator light on the combination meter is flashing), the alarm system will remain armed throughout the remote start run cycle.**
- **If the alarm system is disarmed at the time of remote engine start activation (the security indicator light on the combination meter is not flashing), the alarm system will remain disarmed throughout the remote start run cycle.**

■ Entering the vehicle while it is running via remote start

1. Unlock the vehicle doors using the remote keyless entry system. If the vehicle's doors are unlocked manually using the key, the vehicle's alarm system will trigger (if the alarm system is armed prior to activating the remote engine start system) and the engine will turn off. Inserting the key into the ignition switch and turning it to the "ON" position or pressing the unlock button "Ⓞ" on the

7-12 Starting and operating

remote keyless entry transmitter will disarm the alarm system. Refer to “Alarm system” 2-15.

2. Enter the vehicle.

3. The engine will shut down when any door or trunk/rear gate is opened.

4. Insert the key into the ignition switch and turn to the “START” position to restart the engine.

■ Remote start confirmation transmitter feature

Your remote engine start transmitter is equipped with a unique bidirectional confirmation feature. This feature will allow the transmitter’s backlit button to display the status of the system under the condition that the vehicle and transmitter are within the operational range of the system. Typical transmitter button flash sequences are outlined in the following chart.

Transmitter flash sequence	Feature description
Flashes when button is pressed	Indicates that the system is transmitting an RF signal.
Two long flashes following remote start activation (transmitter button is pressed two times within 3 seconds)	Indicates that the transmitter did not receive the remote start activation confirmation from the vehicle system. The transmitter will automatically send one additional remote start activation attempt. This usually occurs when the operational range is at its limit or has been exceeded.
One flash following remote start activation (transmitter button is pressed two times within 3 seconds)	Indicates that the engine is running via remote start. If the transmitter is moved outside of the operating range of the system, this sequence will timeout after the normal 15-minute vehicle run cycle.
2 flashes every 5 seconds	Indicates that the engine is running via remote start. If the transmitter is removed outside of the operating range of the system, this sequence will timeout after the normal 15-minute vehicle run cycle.
3 flashes	Indicates that the engine has turned off due to a remote start system 15-minute timeout, vehicle safety parameter or normal shutdown.

■ Entering the vehicle following remote engine start shutdown

An alarm trigger may occur if the vehicle is opened by the remote keyless entry transmitter within a few seconds immediately following remote engine start shutdown.

■ Pre-heating or pre-cooling the interior of the vehicle

Models with automatic climate control system:

After the system starts the engine, the automatic climate control system will activate the "FULL AUTO" mode and heat or cool the interior to the predetermined median (room) temperature. No pre-setting of controls is necessary.

Models without automatic climate control system:

Before exiting the vehicle, set the temperature controls to the desired setting and operation. After the system starts the engine, the heater or air conditioning will activate and heat or cool the interior to your setting.

■ Service mode

In service mode, the remote engine start function is temporarily disabled to prevent the system from unexpectedly starting the engine while being serviced.

To engage or disengage service mode:

1. Enter the vehicle and close all vehicle doors and the trunk/rear gate.
2. Verify that the select lever is in the "P" position (AT and CVT models)
3. Depress and hold the brake pedal
4. Turn the ignition switch to the "ON" position
5. Press and release the remote engine start transmitter "Ⓚ" button three times. The system will honk the vehicle's horn each time the button is pressed.
6. The system will pause for 1 second then honk the vehicle's horn three times to indicate that the service mode has been engaged or honk one time to indicate that the service mode has been disengaged.

NOTE

When taking your vehicle in for service, it is recommended that you inform the service personnel that your vehicle is equipped with a remote engine start system.

■ Remote transmitter program

New transmitters can be programmed to the remote engine start system in the event that a transmitter is lost, stolen, damaged or additional transmitters are desired (the system will accept up to eight transmitters). New remote engine start transmitters can be programmed according to the following procedure.

1. Open the driver's door (the driver's door must remain opened throughout the entire process).
2. Depress and hold the brake pedal.
3. Turn the ignition switch to "ON" then "LOCK", back to "ON" then "LOCK", then back to "ON" again and leave the ignition "ON" throughout the programming process.
4. The system will flash the side marker lights, tail lights and front position lights and honk the horn three times, indicating that the system has entered the transmitter learn mode.
5. Press and release the "Ⓚ" button on the transmitter that you want to program.
6. The system will flash the side marker lights, tail lights and front position lights and honk the horn one time, indicating that the system has learned the transmitter. Upon successful programming, the remote start confirmation transmitter button

will flash one time.

7. Repeat step 5 for any additional transmitters (the system will accept up to eight transmitters).

8. The system will exit the transmitter learn mode if the key is turned to the "LOCK" position, the door is closed or after 2 minutes.

■ System maintenance

NOTE

In the event that the vehicle's battery is replaced, discharged or disconnected, it will be necessary to start the vehicle a minimum of one time using the key prior to activating the remote engine start system. This is required to allow the vehicle electronic systems to re-synchronize.

▼ Changing the batteries



CAUTION

- Do not let dust, oil or water get on or in the remote engine start transmitter when replacing the battery.
- Be careful not to damage the printed circuit board in the remote engine start transmitter when replacing the battery.

- Be careful not to allow children to touch the battery and any removed parts; children could swallow them.
- There is a danger of explosion if an incorrect replacement battery is used. Replace only with the same or equivalent type of battery.
- Batteries should not be exposed to excessive heat such as sunshine, fire or the like.

The two 3-volt lithium batteries (model CR-2032) supplied in your remote engine start transmitter should last approximately one year, depending on usage. When the batteries begin to weaken, you will notice a decrease in range (distance from the vehicle that your remote control operates). Follow the instructions below to change the remote engine start transmitter batteries.

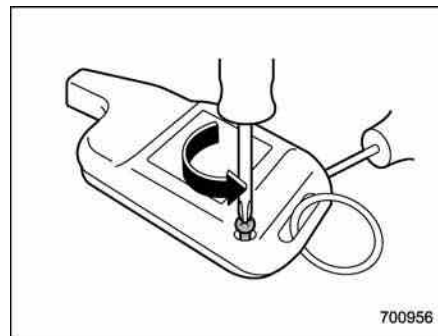

1. Remove the small Phillips type screw located on the back side lower left corner of the transmitter.
2. Carefully pry the remote engine start transmitter halves apart using a small flat-head screwdriver.

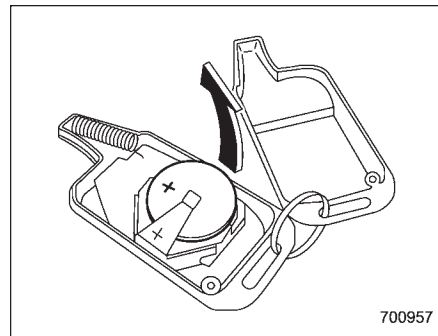

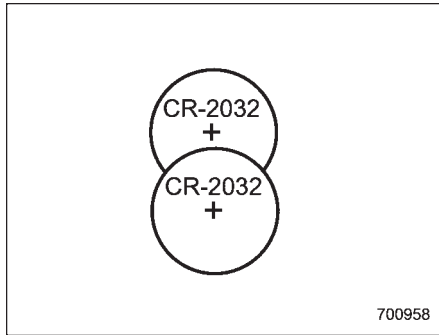

3. Remove the circuit board from the bottom half of the case and remove the batteries and replace with new ones. Be sure to observe the (+) sign on the old batteries before removing them to ensure that the new batteries are inserted properly (battery "+" should be pointed away from the transmitter circuit board on both batteries).

4. Carefully snap the case halves back together, reinstall the Phillips type screw and test the remote engine start system.

NOTE

- This device complies with Part 15 of the FCC Rules and with RSS-210 of Industry Canada. Operation is subject to the following two conditions: (1) This device may not cause harmful inter-

ference, and (2) this device must accept any interference received, including interference that may cause undesired operation.

Changes or modifications not expressly approved by the party responsible for compliance could void the user's authority to operate the equipment and void warranty.

- To comply with the FCC RF exposure compliance requirements, no change to the antenna or the device is permitted. Any change to the antenna or the device could result in the device exceeding the RF exposure requirements and void user's authority to operate the device.

Manual transmission



WARNING

- Do not drive the vehicle with the clutch disengaged (i.e., when the clutch pedal is depressed) or with the shift lever in the neutral position. Engine braking has no effect in either of these conditions and the risk of an accident is consequently increased.
- Do not engage the clutch (i.e., release the clutch pedal) suddenly when starting the vehicle. By doing so the vehicle might unexpectedly accelerate or the transmission could malfunction.

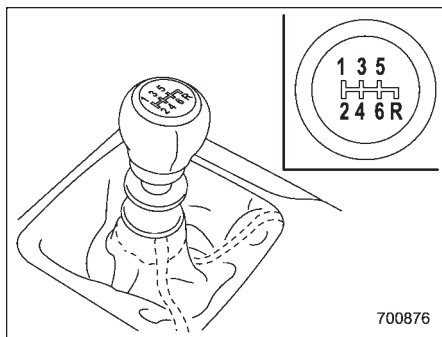

The manual transmission is a fully synchromeshed, 6-forward-speed and 1-reverse-speed transmission.

The shift pattern is shown on the shift lever knob.

■ Selecting reverse gear

⚠ CAUTION

Shift into reverse ONLY when the vehicle has completely stopped. It may cause damage to the transmission to try shifting into reverse when the vehicle is moving.

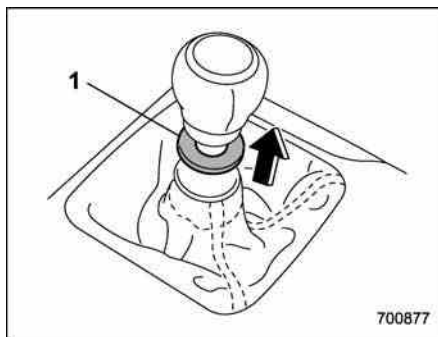

1) Slider

You must raise the slider and hold it in that position before you can move the shift lever to the “R” position.

To change gears, fully depress the clutch pedal, move the shift lever, and gradually let up on the clutch pedal.

If it is difficult to shift into gear, put the transmission in neutral, release the clutch pedal momentarily, and then try again.

■ Shifting speeds

▼ Recommended shifting speeds

The best compromise between fuel economy and vehicle performance during normal driving is ensured by shifting up at the speeds listed in the following table.

Shift up	mph (km/h)
1st to 2nd	15 (24)
2nd to 3rd	25 (40)
3rd to 4th	40 (64)
4th to 5th	45 (72)
5th to 6th	50 (80)

▼ Maximum allowable speeds

⚠ WARNING

When shifting down a gear, ensure that the vehicle is not travelling at a speed exceeding the Maximum Allowable Speed for the gear which is about to be selected. Failure to observe this precaution can lead to engine over-revving and this in turn can result in engine damage.

In addition, sudden application of engine brakes when the vehicle is travelling on a slippery surface can lead to wheel locking; as a consequence, control of the vehicle may be lost and the risk of an accident increased.

The following table shows the maximum speeds that are possible with each different gear. The tachometer’s needle will

enter the red area if these speeds are exceeded.

With the exception of cases where sudden acceleration is required, the vehicle should not be driven with the tachometer's needle inside the red area. Failure to observe this precaution can lead to excessive engine wear and poor fuel economy.

Gear	Legacy		Outback
	Non-turbo models	Turbo models	
1st	32 (52)	35 (56)	32 (52)
2nd	57 (92)	62 (100)	57 (92)

NOTE

Never exceed posted speed limits.

■ Driving tips

Do not drive with your foot resting on the clutch pedal and do not use the clutch to hold your vehicle at a standstill on an upgrade. Either of those actions may cause clutch damage.

Do not drive with your hand resting on the shift lever. This may cause wear on the transmission components.

When it is necessary to reduce vehicle speed due to slow traffic, turning corners,

or driving up steep hills, downshift to a lower gear before the engine starts to labor.

On steep downgrades, downshift the transmission to 5th, 4th, 3rd or 2nd gear as necessary; this helps to maintain a safe speed and to extend brake pad life.

In this way, the engine provides a braking effect. Remember, if you "ride" (over use) the brakes while descending a hill, they may overheat and not work properly.

The engine may, on rare occasions, knock when the vehicle rapidly accelerates or rapidly pulls away from a standstill. This phenomenon does not indicate a problem.

Automatic transmission/Continuously variable transmission

The automatic transmission is electronically controlled and provides 5 forward speeds and 1 reverse speed. The continuously variable transmission is electronically controlled and provides an infinite number of forward speeds and 1 reverse speed.

Both the automatic transmission and continuously variable transmission have a manual mode.



WARNING

Do not shift from the "P" or "N" position into the "D" or "R" position while depressing the accelerator pedal. This may cause the vehicle to jump forward or backward.



CAUTION

- Shift into the "P" or "R" position only after the vehicle is completely stopped. Shifting while the vehicle is moving may cause damage to the transmission.
- Do not race the engine for more

than 5 seconds in any position except the “N” or “P” position when the brake is applied or when chocks are used in the wheels. This may cause the transmission fluid to overheat.

- Avoid shifting from one of the forward driving positions into the “R” position or vice versa until the vehicle has completely stopped. Such shifting may cause damage to the transmission.
- When parking the vehicle, first securely apply the parking brake and then place the select lever in the “P” position. Avoid parking for a long time with the select lever in any other position as doing so could result in a dead battery.

NOTE

- For AT models, when the engine coolant temperature is still low, the transmission will upshift to higher engine speeds than when the coolant temperature is sufficiently high in order to shorten the warm-up time and improve driveability. The gearshift timing will automatically shift to the nor-

mal timing after the engine has warmed up.

- Immediately after transmission fluid is replaced, you may feel that the transmission operation is somewhat unusual. This results from invalidation of data which the on-board computer has collected and stored in memory to allow the transmission to shift at the most appropriate times for the current condition of your vehicle. Optimized shifting will be restored as the vehicle continues to be driven for a while.
- When driving a vehicle that is equipped with CVT under continuous heavy load conditions such as towing a camper or climbing a long, steep hill, the engine speed or the vehicle speed may automatically be reduced. This is not a malfunction. This phenomenon results from the engine control function maintaining the cooling performance of the vehicle. The engine and vehicle speed will return to a normal speed when the engine is able to maintain the optimum cooling performance after the heavy load decreases. Driving under a heavy load must be performed with extreme care. Do not try to pass a vehicle in front when driving on an uphill slope while towing.
- The continuously variable transmission is a chain type system that

provides superior transmission efficiency for maximum fuel economy. At times, depending on varying driving conditions, a chain operating sound may be heard that is characteristic of this type of system.

■ Select lever

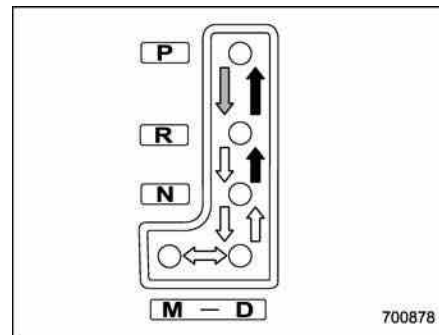

- ➡ : With the brake pedal depressed, shift while pressing the button in
- ➡ : Shift while pressing the button in
- ↔ : Shift without pressing the button

The select lever has four positions, “P”, “R”, “N”, “D” and also has a manual gate for using the manual mode.

▼ P (Park)

This position is for parking the vehicle and starting the engine.

In this position, the transmission is mechanically locked to prevent the vehicle from rolling freely.

When you park the vehicle, first apply the parking brake, then shift into the “P” position. Do not hold the vehicle with only the transmission.

To shift the select lever from the “P” to any other position, you should depress the brake pedal fully then move the select lever. This prevents the vehicle from lurching when it is started.

NOTE

To protect the engine while the “P” position is selected, the engine is controlled such that the engine speed may not become too high even if the accelerator pedal is depressed hard.

▼ R (Reverse)

This position is for backing the vehicle.

To shift from the “N” to “R” position, stop the vehicle completely then move the lever to the “R” position.

▼ N (Neutral)

This position is for restarting a stalled engine.

In this position the wheels and transmission are not locked. In this position, the

transmission is neutral; the vehicle will roll freely, even on the slightest incline unless the parking brake or foot brake is applied. Avoid coasting with the transmission neutral.

During coasting, there is no engine braking effect.

NOTE

- **To protect the engine while the “N” position is selected, the engine is controlled such that the engine speed may not become too high even if the accelerator pedal is depressed hard.**
- **If the select lever is in the “N” position when you stop the engine for parking, you may not subsequently be able to move it to the “R” and “P” positions. If this happens, turn the ignition switch to the “ON” position. You will then be able to move the select lever to the “P” position.**



WARNING

Do not drive the vehicle with the select lever in the “N” (neutral) position. Engine braking has no effect in this condition and the risk of an accident is consequently increased.

▼ D (Drive)

This position is for normal driving. The transmission automatically shifts into a suitable gear according to the vehicle speed and the acceleration you require.

When more acceleration is required in this position, depress the accelerator pedal fully to the floor and hold that position. The transmission will automatically downshift. When you release the pedal, the transmission will return to the original gear position.

To use the manual mode, move the lever from this position into the manual gate.

NOTE (AT models only)

Automatic downshifts to 4th or 3rd may occur even when driving on a level road depending on conditions, such as how hard you depress the brake pedal.

▽ While climbing a grade

When driving up a hill, undesired upshift is prevented from taking place when the accelerator is released. This minimizes the chance of subsequent downshifting to a lower gear when accelerating again. This prevents repeated upshifting and downshifting resulting in a smoother operation of the vehicle.

NOTE

The transmission may downshift, depending on the way the accelerator pedal is depressed to accelerate the vehicle again.

■ Shift lock function

The shift lock function helps prevent the improper operation of the select lever.

- The select lever cannot be operated unless the ignition switch is turned to the "ON" position and the brake pedal is depressed.
- The select lever cannot be moved from the "P" position to any other position before the brake pedal is depressed. Depress the brake pedal first, and then operate the select lever.
- Only the "P" position allows you to turn the key from the "Acc" position to the "LOCK" position and remove the key from the ignition key cylinder.
- If the ignition switch is turned to the "LOCK" position while the select lever is in the "N" position, the select lever may not be moved to the "P" position after a period of time. Therefore, move the select lever to the "P" position with the brake pedal depressed soon after the ignition switch is turned to the "LOCK" position.

▼ Shift lock release

If the select lever cannot be operated, turn the ignition switch back to the "ON" position then move the select lever to the "P" position with the select lever button pressed and brake pedal depressed.

If the select lever does not move after performing the above procedure, perform the following steps.

● When the select lever cannot be shifted from "P" to "N":

Refer to "Shift lock release using the shift lock release button" 7-20.

● When the select lever cannot be shifted from "N" to "R", "P":

Within 60 seconds after placing the ignition switch in the "Acc" position, move the select lever to the "P" position with the select lever button pressed and brake pedal depressed.

If you must perform the above procedure, the shift lock system (or the vehicle control system) may be malfunctioning. Contact a SUBARU dealer for an inspection as soon as possible.

If the select lever does not move after performing the above procedure, refer to "Shift lock release using the shift lock release button" 7-20.

▼ Shift lock release using the shift lock release button

Perform the following procedure to release the shift lock.

1. Apply the parking brake and stop the engine.

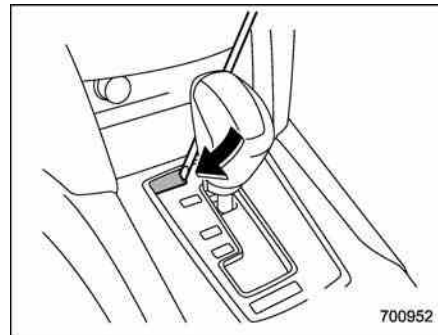

2. Remove the shift lock cover using a flat-head screwdriver.

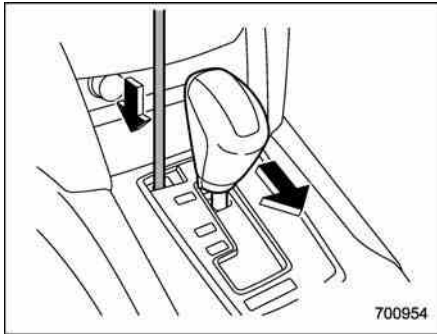

3. While depressing the brake pedal, insert the electronic parking brake release tool into the hole, press the shift lock release button using the tool, and then move the select lever.

NOTE

To prevent damage to the shift lock cover, cover the tip of the flat-head screwdriver with vinyl tape or a cloth before removing the cover.

If the select lever does not move after performing the above procedure, the shift lock system may be malfunctioning. Contact a SUBARU dealer for an inspection as soon as possible.

■ Selection of manual mode

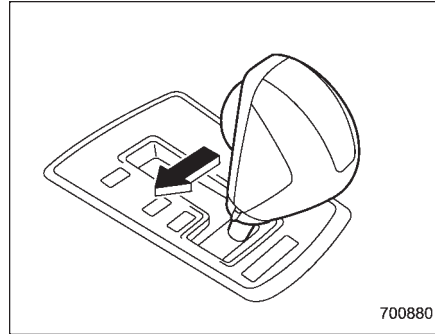

With the vehicle either moving or stationary, move the select lever from the “D” position to the “M” position to select the manual mode.

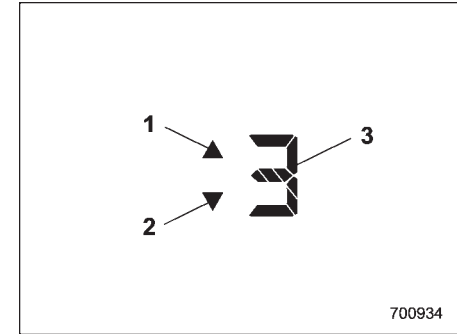

- 1) Upshift indicator
- 2) Downshift indicator
- 3) Gear position indicator

When the manual mode is selected, the gear position indicator and upshift indicator and/or downshift indicator on the combination meter illuminate. The gear position indicator shows the currently selected gear in the 1st-to-5th-gear range (AT models) or 1st-to-6th gear range (CVT models). The upshift and downshift indicators show when a gearshift is possible. When the upshift indicator “ \triangle ” is on, upshifting is possible. When the downshift indicator “ ∇ ” is on, downshifting is possible. When both indicators are on, upshifting and downshifting are both possible. When the vehicle stops (for example, at traffic signals), the downshift indicator

turns off.

Gearshifts can be performed using the paddle shift switch behind the steering wheel.

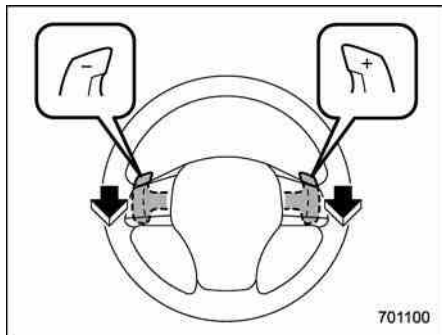

Pull the “+” of the paddle shift to upshift one level. Also pull the “-” of the paddle shift to downshift one level.

To deselect the manual mode, return the select lever to the “D” position from the “M” position.

While driving with the select lever in the “D” position, if you change gears by paddle shifting, the gear position indicator light illuminates and shows the current gear condition.

CAUTION

Do not place or hang anything on the paddle shift levers. Doing so may result in accidental gear shifting.

NOTE

Please read the following points carefully and bear them in mind when using the manual mode.

- If you attempt to shift down when the engine speed is too high, i.e., when a downshift would push the tachometer needle beyond the red zone, beeps will be emitted to warn you that the downshift is not possible.
- If you attempt to shift up when the vehicle speed is too low, the transmission will not respond.
- You can perform a skip-shift (for example, from 4th to 2nd) by operating the paddle switch twice in rapid succession.
- The transmission automatically selects 1st gear when the vehicle stops moving.
- If the temperature of the transmission fluid becomes too high, the “AT OIL TEMP” warning light will illuminate. Immediately stop the vehicle in a safe

place and let the engine idle until the warning light turns off.

Driving tips

- On a road surface where there is a risk of wheelspin (for example, a snow- or gravel-covered road), you can pull away from a standstill safely and easily by first selecting the 2nd gear of the manual mode.
- Always apply the foot or parking brake when the vehicle is stopped in the “D” or “R” position.
- Always apply the parking brake when parking your vehicle. Do not hold the vehicle with only the transmission.
- Do not keep the vehicle in a stationary position on an uphill grade by using the “D” position. Use the brake instead.
- The engine may, on rare occasions, knock when the vehicle rapidly accelerates or rapidly pulls away from a standstill. This phenomenon does not indicate a malfunction.
- A slight reduction in output torque may occur in the models with a 2.5 L turbo or 3.6 L engine before the engine warms up.

Power steering

CAUTION

Do not hold the steering wheel at the fully locked position left or right for more than 5 seconds. This may damage the power steering pump.

The power steering system operates only when the engine is running.

If you lose power steering assist because the engine stops or the system fails to function, you can steer but it will take much more effort.

NOTE

Right after the engine has been started and before it has warmed up, you may hear a noise coming from areas adjacent to the power steering pump which is located at the right-front area of the engine compartment. This noise is normal. It does not indicate power steering system trouble.

Braking

■ Braking tips

WARNING

Never rest your foot on the brake pedal while driving. This can cause dangerous overheating of the brakes and needless wear on the brake pads and linings.

▼ When the brakes get wet

When driving in rain or after washing the vehicle, the brakes may get wet. As a result, brake stopping distance will be longer. To dry the brakes, drive the vehicle at a safe speed while lightly depressing the brake pedal to heat up the brakes.

▼ Use of engine braking

Remember to make use of engine braking in addition to foot braking. When descending a grade, if only the foot brake is used, the brakes may start working improperly because of brake fluid overheating, caused by overheated brake pads. To help prevent this, shift into a lower gear to get stronger engine braking.

▼ Braking when a tire is punctured

Do not depress the brake pedal suddenly when a tire is punctured. This could cause

a loss of control of the vehicle. Keep driving straight ahead while gradually reducing speed. Then slowly pull off the road to a safe place.

■ Brake system

▼ Two separate circuits

Your vehicle has a dual circuit brake system. Each circuit works diagonally across the vehicle. If one circuit of the brake system should fail, the other half of the system still works. If one circuit fails, the brake pedal will go down much closer to the floor than usual and you will need to press it down much harder. And a much longer distance will be needed to stop the vehicle.

▼ Brake booster

The brake booster uses engine manifold vacuum to assist braking force. Do not turn off the engine while driving because that will turn off the brake booster, resulting in poor braking power.

The brakes will continue to work even when the brake booster completely stops functioning. If this happens, however, you will have to depress the pedal much harder than normal and the braking distance will increase.

▼ Brake assist system

WARNING

Do not be overconfident about the brake assist. It is not a system that brings more braking ability to the vehicle beyond its braking capability. Always use the utmost care when driving regarding vehicle speed and safe distance.

CAUTION

When you need to brake suddenly, continue depressing the brake pedal strongly to bring the effect of the brake assist.

Brake assist is a driver assistance system. It assists the brake power when the driver cannot depress the brake pedal strongly and the brake power is insufficient.

Brake assist generates the brake power according to the speed at which the driver depresses the brake pedal.

NOTE

When you depress the brake pedal strongly or suddenly, the following phenomena occur. However, even though these occur, they do not indi-

cate any malfunctions, and the brake assist system is operating properly.

- You might feel that the brake pedal is applied by lighter force and generates a greater braking force.
- You might hear the sound of ABS operating from the engine compartment.

■ Disc brake pad wear warning indicators

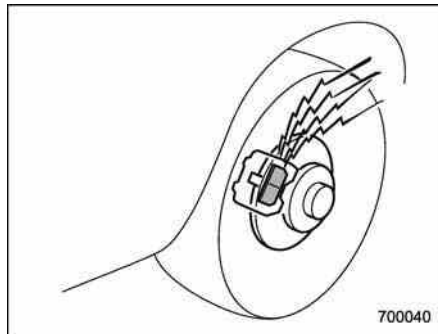

The disc brake pad wear warning indicators on the disc brakes give a warning noise when the brake pads are worn.

If a squeaking or scraping noise is heard from the disc brakes while braking, immediately have your vehicle inspected by the nearest SUBARU dealer.

ABS (Anti-lock Brake System)

WARNING

Always use the utmost care in driving – overconfidence because you are driving with an ABS equipped vehicle could easily lead to a serious accident.

CAUTION

- The ABS system does not always decrease stopping distance. You should always maintain a safe following distance from other vehicles.
- When driving on badly surfaced roads, gravel roads, icy road, or over deep newly fallen snow, stopping distances may be longer for a vehicle with the ABS system than one without. When driving under these conditions, therefore, reduce your speed and leave ample distance from other vehicles.
- When you feel the ABS system operating, you should maintain

constant brake pedal pressure. Do not pump the brake pedal since doing so may defeat the operation of the ABS system.

The ABS system prevents the lock-up of wheels which may occur during sudden braking or braking on slippery road surfaces. This helps prevent the loss of steering control and directional stability caused by wheel lock-up.

When the ABS system is operating, you may hear a chattering noise or feel a slight vibration in the brake pedal. This is normal when the ABS operates.

The ABS system will not operate when the vehicle speed is below approximately 6 mph (10 km/h).

■ ABS system self-check

You may feel a slight shock in the brake pedal and hear the operating sound of ABS from the engine compartment just after the vehicle is started. This is caused by an automatic functional test of the ABS system being carried out and does not indicate any abnormal condition.

■ ABS warning light

Refer to "ABS warning light" 3-16.

Electronic Brake Force Distribution (EBD) system

The EBD system maximizes the effectiveness of the brakes by allowing the rear brakes to supply a greater proportion of the braking force. It functions by adjusting the distribution of braking force to the rear wheels in accordance with the vehicle's loading condition and speed.

The EBD system is an integral part of the ABS system and uses some of the ABS system's components to perform its function of optimizing the distribution of braking force. If any of the ABS components used by the EBD function fails, the EBD system also stops working.

When the EBD system is operating, you may hear a chattering noise or feel a slight vibration in the brake pedal. This is normal and does not indicate a malfunction.

■ Steps to take if EBD system malfunctions

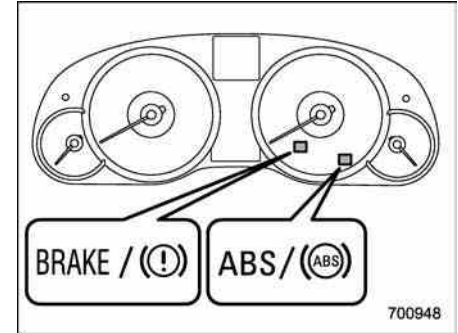

If a malfunction occurs in the EBD system, the system stops working and the brake system warning light and ABS warning light illuminate simultaneously.

The EBD system may be malfunctioning if the brake system warning light and ABS warning light illuminate simultaneously during driving.

Even if the EBD system fails, the conventional braking system will still function. However, the rear wheels will be more prone to locking when the brakes are applied harder than usual and the vehicle's motion may therefore become somewhat harder to control.

If the brake system warning light and ABS

warning light illuminate simultaneously, take the following steps.

1. Stop the vehicle in the nearest safe, flat place.

2. Shut down the engine, then restart it.

3. Release the parking brake. If both warning lights turn off, the EBD system may be malfunctioning.

Drive carefully to the nearest SUBARU dealer and have the system inspected.

4. If both warning lights illuminate again and remain illuminated after the engine has been restarted, shut down the engine again, apply the parking brake, and check the brake fluid level. Refer to "Brake fluid" 11-25.

5. If the brake fluid level is not below the "MIN" mark, the EBD system may be malfunctioning. Drive carefully to the nearest SUBARU dealer and have the system inspected.

6. If the brake fluid level is below the "MIN" mark, DO NOT drive the vehicle. Instead, have the vehicle towed to the nearest SUBARU dealer for repair.



WARNING

- Driving with the brake system warning light on is dangerous. This indicates your brake system

may not be working properly. If the light remains on, have the brakes inspected by a SUBARU dealer immediately.

- If at all in doubt about whether the brakes are operating properly, do not drive the vehicle. Have your vehicle towed to the nearest SUBARU dealer for repair.

Vehicle Dynamics Control system



WARNING

Always use the utmost care in driving – overconfidence because you are driving with a Vehicle Dynamics Control system equipped vehicle could easily lead to a serious accident.



CAUTION

- Even if your vehicle is equipped with Vehicle Dynamics Control system, winter tires should be used when driving on snow-covered or icy roads; in addition, vehicle speed should be reduced considerably. Simply having a Vehicle Dynamics Control system does not guarantee that the vehicle will be able to avoid accidents in any situation.
- Activation of the Vehicle Dynamics Control system is an indication that the road being travelled on has a slippery surface; since having Vehicle Dynamics Control is no guarantee

that full vehicle control will be maintained at all times and under all conditions, its activation should be seen as a sign that the speed of the vehicle should be reduced considerably.

- Whenever suspension components, steering components, or an axle are removed from a vehicle equipped with the Vehicle Dynamics Control system, have an inspection of that system performed by an authorized SUBARU dealer.
- The following precautions should be observed in order to ensure that the Vehicle Dynamics Control system is operating properly.
 - All four wheels should be fitted with tires of the same size, type, and brand. Furthermore, the amount of wear should be the same for all four tires.
 - Keep the tire pressure at the proper level as shown on the vehicle placard attached to the driver's side door pillar.
 - Use only the specified temporary spare tire to replace a flat tire. With a temporary

spare tire, the effectiveness of the Vehicle Dynamics Control system is reduced and this should be taken into account when driving the vehicle in such a condition.

- If non-matching tires are used, the Vehicle Dynamics Control system may not operate correctly.

In the event of wheelspin and/or skidding on a slippery road surface and/or during cornering and/or an evasive maneuver, the Vehicle Dynamics Control system adjusts the engine's output and the wheels' respective braking forces to help maintain traction and directional control.

● Traction Control Function

The traction control function is designed to prevent spinning of the driving wheels on slippery road surfaces, thereby helping to maintain traction and directional control. Activation of this function is indicated by flashing of the Vehicle Dynamics Control operation indicator light.

● Skid Suppression Function

The skid suppression function is designed to help maintain directional stability by suppressing the wheels' tendency to slide sideways during steering operations. Acti-

vation of this function is indicated by flashing of the Vehicle Dynamics Control operation indicator light.

NOTE

- The Vehicle Dynamics Control system may be considered normal when the following conditions occur.
 - Slight twitching of the brake pedal is felt.
 - The vehicle or steering wheel shakes to a small degree.
 - An operating sound from the engine compartment is heard briefly when starting the engine and when driving off after starting the engine.
 - The brake pedal seems to jolt when driving off after starting the engine.
- In the following circumstances, the vehicle may be less stable than it feels to the driver. The Vehicle Dynamics Control System may therefore operate. Such operation does not indicate a system malfunction.
 - on gravel-covered or rutted roads
 - on unfinished roads
 - when the vehicle is towing a trailer
 - when the vehicle is fitted with

snow tires or winter tires

- Activation of the Vehicle Dynamics Control system will cause operation of the steering wheel to feel slightly different compared to that for normal conditions.
- It is always important to reduce speed when approaching a corner, even if the vehicle is equipped with Vehicle Dynamics Control.
- Always turn off the engine before replacing a tire as failure to do so may render the Vehicle Dynamics Control system unable to operate correctly.

■ Vehicle Dynamics Control system monitor

Refer to “Vehicle Dynamics Control warning light/Vehicle Dynamics Control operation indicator light” 3-20 and “Vehicle Dynamics Control OFF indicator light” 3-21.

■ Vehicle Dynamics Control OFF switch

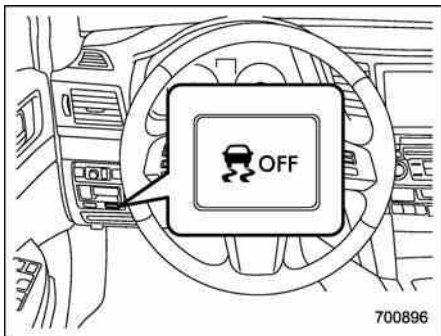

Pressing the switch to deactivate the Vehicle Dynamics Control system can facilitate the following operations.

- a standing start on a steeply sloping road with a snowy, gravel-covered, or otherwise slippery surface
- extrication of the vehicle when its wheels are stuck in mud or deep snow

When the switch is pressed during engine operation, the Vehicle Dynamics Control OFF indicator light on the combination meter illuminates. The Vehicle Dynamics Control system will be deactivated. When the switch is pressed again to reactivate the Vehicle Dynamics Control system, the Vehicle Dynamics Control OFF indicator

light turns off.

You should not deactivate the Vehicle Dynamics Control system except under the above-mentioned situations.



CAUTION

The Vehicle Dynamics Control system helps prevent unstable vehicle motion such as skidding using control of the brakes and engine power. Do not turn off the Vehicle Dynamics Control system unless it is absolutely necessary. If you must turn off the Vehicle Dynamics Control system, drive very carefully based on the road surface condition.

NOTE

- When the switch has been pressed to deactivate the Vehicle Dynamics Control system, the Vehicle Dynamics Control system automatically reactivates itself the next time the ignition switch is turned to the “LOCK” position and the engine is restarted.
- If the switch is held down for 10 seconds or longer, the indicator light turns off, the Vehicle Dynamics Control system is activated, and the system ignores any further pressing of the switch. To make the switch usable

again, turn the ignition switch to the “LOCK” position and restart the engine.

- When the switch is pressed to deactivate the Vehicle Dynamics Control system, the vehicle’s running performance is comparable with that of a vehicle that does not have a Vehicle Dynamics Control system. Do not deactivate the Vehicle Dynamics Control system except when absolutely necessary.

- Even when the Vehicle Dynamics Control system is deactivated, components of the brake control system may still activate. When the brake control system is activated, the Vehicle Dynamics Control operation indicator light illuminates.

Tire pressure monitoring system (TPMS) (if equipped)

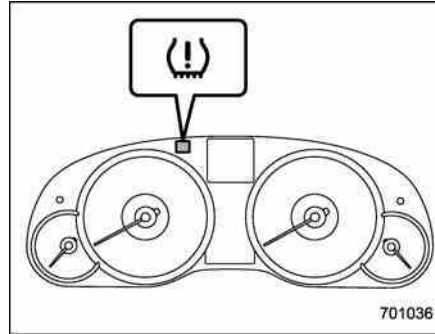

The tire pressure monitoring system provides the driver with a warning message by sending a signal from a sensor that is installed in each wheel when tire pressure is severely low.

The tire pressure monitoring system will activate only when the vehicle is driven at speeds above 20 mph (32 km/h). Also, this system may not react immediately to a sudden drop in tire pressure (for example, a blow-out caused by running over a sharp object).

WARNING

If the low tire pressure warning light illuminates while driving, never brake suddenly and keep driving straight ahead while gradually reducing speed. Then slowly pull off the road to a safe place. Otherwise an accident involving serious vehicle damage and serious personal injury could occur.

Check the pressure for all four tires and adjust the pressure to the COLD tire pressure shown on the tire placard on the door pillar on the driver’s side.

Even when the vehicle is driven a very short distance, the tires get warm and their pressures increase accordingly. Be sure to let the tires cool thoroughly before adjusting their pressures to the standard values shown on the tire placard. Refer to “Tires and wheels”  11-30. The tire pressure monitoring system does not function when the vehicle is stationary. After adjusting the tire pressures, increase the vehicle speed to at least 20 mph (32 km/h) to start the TPMS re-checking of the tire inflation pressures. If the tire pressures are now above the severe

low pressure threshold, the low tire pressure warning light should turn off a few minutes later.

If this light still illuminates while driving after adjusting the tire pressure, a tire may have significant damage and a fast leak that causes the tire to lose air rapidly. If you have a flat tire, replace it with a spare tire as soon as possible.

When a spare tire is mounted or a wheel rim is replaced without the original pressure sensor/transmitter being transferred, the low tire pressure warning light will illuminate steadily after blinking for approximately one minute. This indicates the TPMS is unable to monitor all four road wheels. Contact your SUBARU dealer as soon as possible for tire and sensor replacement and/or system resetting.

Do not inject any tire liquid or aerosol tire sealant into the tires, as this may cause a malfunction of the tire pressure sensors. If the light illuminates steadily after blinking for approximately one minute, promptly contact a SUBARU dealer to have the system inspected.



CAUTION

Do not place metal film or any metal parts under the driver's seat. This may cause poor reception of the signals from the tire pressure sensors, and the tire pressure monitoring system will not function properly.

NOTE

This device complies with Part 15 of the FCC Rules and with RSS-210 of Industry Canada. Operation is subject to the following two conditions: (1) This device may not cause harmful interference, and (2) this device must accept any interference received, including interference that may cause undesired operation.

Changes or modifications not expressly approved by the party responsible for compliance could void the user's authority to operate the equipment.



WARNING

Parking your vehicle

- Never leave unattended children or pets in the vehicle. They could accidentally injure themselves or others through inadvertent operation of the vehicle. Also, on hot or sunny days, the temperature in a closed vehicle could quickly become high enough to cause severe or possibly fatal injuries to them.
- Do not park the vehicle over flammable materials such as dry grass, waste paper or rags, as they may burn easily if they come near hot engine or exhaust system parts.
- Be sure to stop the engine if you take a nap in the vehicle. If engine exhaust gas enters the passenger compartment, occupants in the vehicle could die from carbon monoxide (CO) contained in the exhaust gas.

■ Electronic parking brake

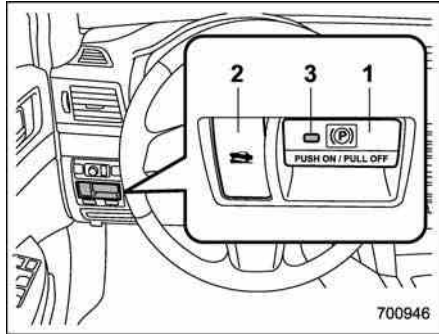

- 1) Parking brake switch
- 2) Hill Holder switch
- 3) Indicator light

⚠ WARNING

- Before exiting the vehicle, make sure that you turn off the engine. Otherwise, the parking brake may be released and an accident may occur.
- If the brake system warning light flashes, the electronic parking brake system may be malfunctioning. Immediately stop your vehicle in a safe location, use tire stops under the tires to prevent the vehicle from moving

and contact your SUBARU dealer.

⚠ CAUTION

- When the electronic parking brake system has a malfunction and the parking brake cannot be applied, contact your SUBARU dealer immediately for an inspection. If you have to park your vehicle in such conditions, perform the following procedure.
 - Stop your vehicle in a flat location.
 - Shift the shift lever in the “1” or reverse position (MT models).
 - Shift the select lever in the “P” position (AT or CVT models). When the select lever cannot be shifted into the “P” position, you must release shift lock. Refer to “Shift lock function” 7-20.
 - Use tire stops under the tires to prevent the vehicle from moving.
- Never drive while the parking brake is applied because this will

cause unnecessary wear on the brake linings. Before starting to drive, always make sure that the parking brake has been released and the brake system warning light has turned off.

Your vehicle is equipped with an electronic parking brake. You can apply/release the parking brake by operating the parking brake switch.

To apply: Depress the brake pedal and press the parking brake switch firmly.

To release: Pull the parking brake switch toward you while the ignition switch is in the “ON” position and the brake pedal (all models) and the clutch pedal (MT models) are depressed.

When the parking brake is applied while the ignition switch is in the “ON” position, the brake system warning light and the indicator light on the parking brake switch illuminate. Refer to “Brake system warning light” 3-17.

NOTE

- If the parking brake switch is pulled with the ignition switch in the “Acc” or “LOCK” position, the parking brake is not released.
- If the parking brake switch is pulled

without depressing the brake pedal or the clutch pedal, the parking brake is not released.

- When the parking brake is being applied or released, noise may be noticed. However, this is not a malfunction.

- When the electronic parking brake system has a malfunction or the electronic parking brake operation is prohibited temporarily, if the parking brake switch is operated, a chirp sound is heard and the brake system warning light flashes.

- When you cannot release the parking brake due to, for example, a system malfunction, you can release it by using the parking brake release tool. Refer to “Electronic parking brake – if the electronic parking brake cannot be released” 9-17.

▼ Automatic release function by accelerator pedal

The electronic parking brake system has an automatic release function. The parking brake will be automatically released by depressing the accelerator pedal. However, the automatic release function does not operate under the following conditions.

- Any door (other than the trunk lid or rear gate) is open.

- The driver’s seatbelt is not fastened.

If the parking brake is automatically released, the brake system warning light and the indicator light on the parking brake switch turn off.

NOTE

Even if you have applied the parking brake by pressing the parking brake switch, the parking brake will be automatically released when the accelerator pedal is depressed.

▼ Hill Holder function

The electronic parking brake system has a Hill Holder function. If the Hill Holder function is activated, the parking brake will be automatically applied when stopping on an uphill slope with the brake pedal depressed. In this case, the brake system warning light and the indicator light on the parking brake switch illuminate.

NOTE

- The Hill Holder function may not activate on a gentle uphill slope. In this case, manually apply the electronic parking brake.

- If you do not depress the brake pedal sufficiently, the Hill Holder function may not operate properly. However, this is not a malfunction. When

stopping on an uphill slope, depress the brake pedal firmly and release it after the brake system warning light illuminates.

- Depending on the condition of the road surface and braking force, the brakes operate temporarily and feel different than usual.

- When the electronic parking brake system has a malfunction while the Hill Holder function is activated, a chirp sound is heard, the Hill Holder indicator light turns off and the brake system warning light flashes.

- The Hill Holder function does not reactivate when parking with the electronic parking brake released after the Hill Holder function is activated. If necessary, manually apply the electronic parking brake.

- If the seatbelt is not fastened when the Hill Holder function is activated, the vehicle may not start moving smoothly from a stop, or a noise may be heard from the brake components.

▽ Hill Holder switch



When stopping on an uphill slope with the Hill Holder function activated, release the brake pedal after

the brake system warning light has illuminated. Otherwise, the Hill Holder function may not operate properly and an accident may occur.

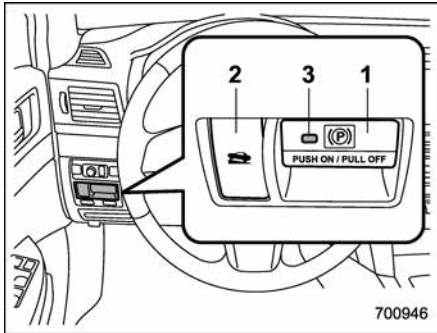

- 1) Parking brake switch
- 2) Hill Holder switch
- 3) Indicator light

You can activate/deactivate the Hill Holder function by pressing the Hill Holder switch.

To activate: Press the Hill Holder switch.

To deactivate: Press the Hill Holder switch again.

Deactivate the Hill Holder function under the following conditions.

- When towing a trailer
- When carrying a heavy load

- When you do not frequently use the parking brake when stopping on an uphill slope

NOTE

- If the Hill Holder switch is pressed for more than 30 seconds, the Hill Holder indicator light turns off, the brake system warning light flashes and the system ignores any further pressing of the switch. To activate the switch again, turn the ignition switch to the “LOCK” position and restart the engine.
- When the Hill Holder function is deactivated while the Hill Holder function has a malfunction, if you press the Hill Holder switch, a chirp sounds.

▽ Hill Holder indicator light

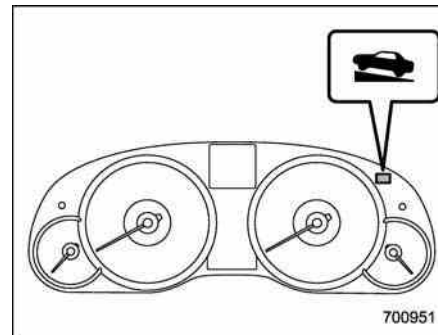

When the Hill Holder function is activated, the Hill Holder indicator light illuminates. Refer to “Hill Holder indicator light” 3-19.

▼ Emergency brake

CAUTION

Use the emergency brake only in case of an emergency. If the emergency brake is excessively used, the brake parts will wear down faster or the brake may not work sufficiently due to rear wheel brake overheating.

NOTE

While using the emergency brake, the brake system warning light and the indicator light on the parking brake switch illuminate and a chirp sounds.

If the foot brake has a malfunction, you can stop the vehicle by pressing the parking brake switch continuously.

While applying the emergency brake, the brake system warning light and the indicator light on the parking brake switch illuminate and a chirp sounds.

▼ Electronic parking brake system warning



CAUTION

If the brake system warning light flashes, the electronic parking brake system may be malfunctioning. Immediately stop your vehicle in the nearest safe location and contact your SUBARU dealer.

If a malfunction occurs in the electronic parking brake system, the brake system warning light flashes. Refer to “Electronic parking brake system warning” 3-18.

■ Parking tips

When parking your vehicle, always perform the following items.

- Apply the parking brake.
- For MT models, put the shift lever in the “1” (1st) for upgrade or “R” (Reverse) for downgrade.
- For AT and CVT models, put the select lever in the “P” (Park) position.

Never rely on the transmission alone to hold the vehicle.

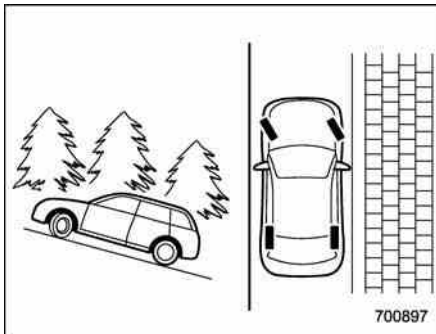

When parking on a hill, always turn the steering wheel as described here. When the vehicle is headed up the hill, the front wheels should be turned away from the curb.

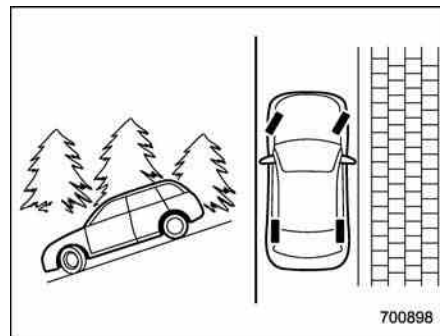

When facing downhill, the front wheels should be turned into the curb.

Cruise control

Cruise control enables you to maintain a constant vehicle speed without holding your foot on the accelerator pedal and it is operative when the vehicle speed is 25 mph (40 km/h) or more.

WARNING

Do not use the cruise control under any of the following conditions. These may cause loss of vehicle control.

- driving up or down a steep grade
- driving on slippery or winding roads
- driving in heavy traffic
- towing a trailer

NOTE

- If you press the “CRUISE” main switch button while turning the ignition switch “ON”, the cruise control function is deactivated and the cruise control indicator light flashes. To reactivate the cruise control function, turn the ignition switch back to the “Acc” or “LOCK” position, and then turn it again to the “ON” position.
- Make sure the “CRUISE” main

switch is turned off when the cruise control is not in use to avoid unintentionally setting of the cruise control.

■ To set cruise control

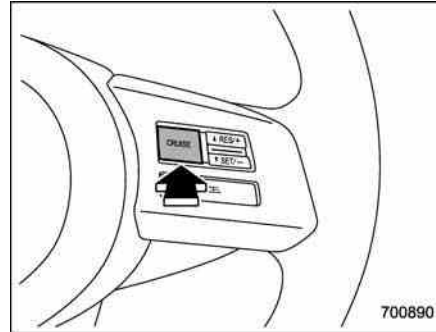

1. Press the “CRUISE” main switch button.

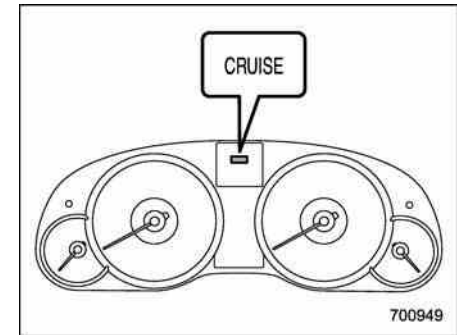

2. Depress the accelerator pedal until the vehicle reaches the desired speed.

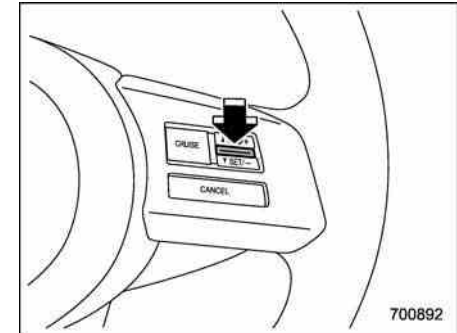

3. Press the “RES/SET” switch to the “SET” side and release it. Then release

the accelerator pedal.

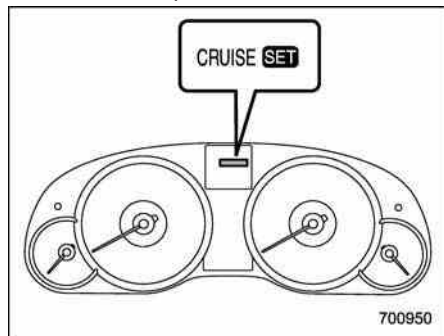

At this time, the cruise control set indicator light is illuminated in the combination meter.

The vehicle will maintain the desired speed.

Vehicle speed can be temporarily increased while driving with the cruise control activated. Simply depress the accelerator pedal to accelerate the vehicle. When the accelerator pedal is released, the vehicle will return to and maintain the previous cruising speed.

■ To temporarily cancel the cruise control

The cruise control can be temporarily canceled in the following ways.

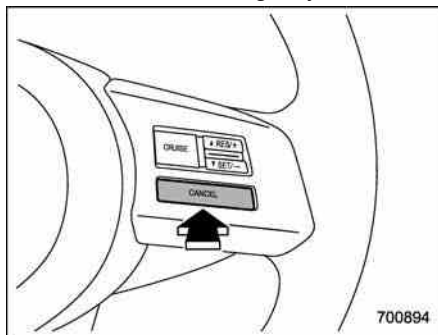

- Press the "CANCEL" button.
- Depress the brake pedal.
- Depress the clutch pedal (MT models only).
- Shift the select lever into the "N" position (AT and CVT models).
- Shift the shift lever into the neutral position (MT models only).

The cruise control set indicator light in the combination meter turns off when the cruise control is canceled.

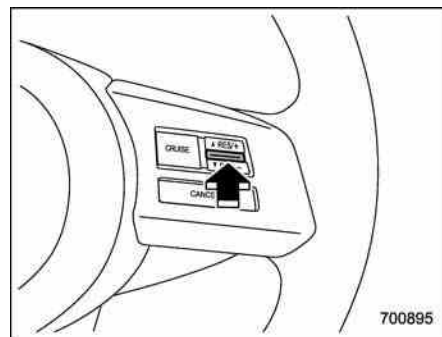

To resume the cruise control after it has been temporarily canceled and with vehicle speed of approximately 20 mph (32 km/h) or more, press the "RES/SET" switch to the "RES" side to return to the original cruising speed automatically.

The cruise control set indicator light in the combination meter will automatically illuminate at this time.

■ To turn off the cruise control

There are two ways to turn off the cruise control:

- Press the "CRUISE" main switch button again.
- Turn the ignition switch to the "Acc" or "LOCK" position (but only when the vehicle is completely stopped).

■ To change the cruising speed

▼ To increase the speed (by the “RES/SET” switch)

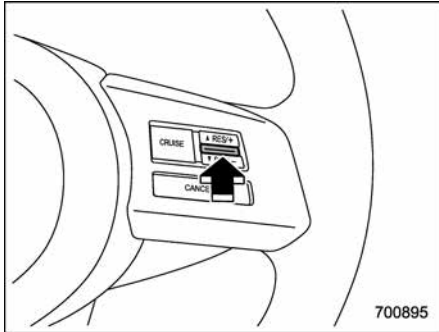

Press the “RES/SET” switch to the “RES” side and hold it until the vehicle reaches the desired speed. Then, release the switch. The vehicle speed at that moment will be memorized and treated as the new set speed.

U.S. spec. models

When the difference between the actual vehicle speed and the set speed is less than 4 mph (6.8 km/h), the set speed can be increased 1 mph (1.6 km/h) each time by pressing the “RES/SET” switch to the “RES” side quickly.

Except U.S. spec. models

When the difference between the actual vehicle speed and the set speed is less than 4.4 km/h, the set speed can be increased 1 km/h each time by pressing the “RES/SET” switch to the “RES” side quickly.

▼ To increase the speed (by accelerator pedal)

1. Depress the accelerator pedal to accelerate the vehicle to the desired speed.
2. Press the “RES/SET” switch to the “SET” side once. Now the desired speed is set and the vehicle will keep running at that speed without depressing the accelerator pedal.

NOTE

● U.S. spec. models

If the difference between the actual vehicle speed when the button is pressed and the speed last time you set is less than 4 mph (6.8 km/h), the vehicle speed will be lowered by 1 mph (1.6 km/h). This occurs because the cruise control system regards this operation as that intended to decrease the vehicle speed.

● Except U.S. spec. models

If the difference between the actual

vehicle speed when the button is pressed and the speed last time you set is less than 4.4 km/h, the vehicle speed will be lowered by 1 km/h. This occurs because the cruise control system regards this operation as that intended to decrease the vehicle speed.

▼ To decrease the speed (by the “RES/SET” switch)

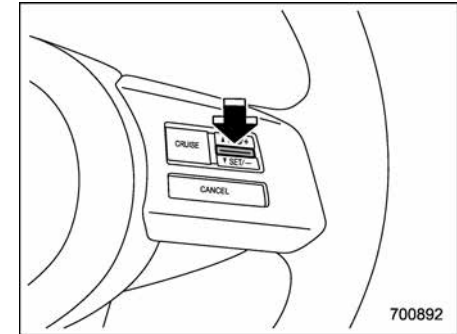

Press the “RES/SET” switch to the “SET” side and hold it until the vehicle reaches the desired speed. Then, release the switch. The vehicle speed at that moment will be memorized and treated as the new set speed.

U.S. spec. models

When the difference between the actual

vehicle speed and the set speed is less than 4 mph (6.8 km/h), the set speed can be lowered 1 mph (1.6 km/h) each time by pressing the “RES/SET” switch to the “SET” side quickly.

Except U.S. spec. models

When the difference between the actual vehicle speed and the set speed is less than 4.4 km/h, the set speed can be lowered 1 km/h each time by pressing the “RES/SET” switch to the “SET” side quickly.

▼ To decrease the speed (by brake pedal)

1. Depress the brake pedal to release cruise control temporarily.
2. When the speed decreases to the desired speed, press the “RES/SET” switch to the “SET” side once. Now the desired speed is set and the vehicle will keep running at that speed without depressing the accelerator pedal.

■ Cruise control indicator light

Refer to “Cruise control indicator light”
☞ 3-23.

■ Cruise control set indicator light

Refer to “Cruise control set indicator light”
☞ 3-23.

New vehicle break-in driving – the first 1,000 miles (1,600 km)	8-2	Rocking the vehicle	8-12
Fuel economy hints	8-2	Loading your vehicle	8-12
Engine exhaust gas (carbon monoxide).....	8-2	Vehicle capacity weight.....	8-13
Catalytic converter	8-3	GVWR and GAWR (Gross Vehicle Weight Rating and Gross Axle Weight Rating)	8-14
Periodic inspections	8-4	Roof rails with integrated crossbars (Outback)	8-14
Driving in foreign countries	8-4	Trailer hitch (Outback — if equipped)	8-17
Driving tips for AWD vehicles	8-5	Connecting a trailer	8-18
Off road driving	8-6	When you do not tow a trailer	8-19
Legacy	8-6	Trailer towing	8-19
Outback	8-6	Warranties and maintenance	8-19
Winter driving	8-8	Maximum load limits	8-20
Operation during cold weather	8-8	Trailer hitches.....	8-23
Driving on snowy and icy roads	8-10	Connecting a trailer	8-24
Corrosion protection	8-11	Trailer towing tips	8-25
Snow tires	8-11		
Tire chains	8-12		

New vehicle break-in driving – the first 1,000 miles (1,600 km)

The performance and long life of your vehicle are dependent on how you handle and care for your vehicle while it is new. Follow these instructions during the first 1,000 miles (1,600 km):

- Do not race the engine. And do not allow engine speed to exceed 4,000 rpm except in an emergency.
- Do not drive at one constant engine or vehicle speed for a long time, either fast or slow.
- Avoid starting suddenly and rapid acceleration, except in an emergency.
- Avoid hard braking, except in an emergency.

The same break-in procedures should be applied to a newly installed or overhauled engine or when brake pads or brake linings are replaced with new ones.

Fuel economy hints

The following suggestions will help to save your fuel.

- Select the proper gear position for the speed and road conditions.
- Avoid sudden acceleration or deceleration. Always accelerate gently until you reach the desired speed. Then try to maintain that speed for as long as possible.
- Do not pump the accelerator and avoid racing the engine.
- Avoid unnecessary engine idling.
- Keep the engine properly tuned.
- Keep the tires inflated to the correct pressure shown on the tire placard, which is located under the door latch on the driver's side. Low pressure will increase tire wear and fuel consumption.
- Use the air conditioner only when necessary.
- Keep the front and rear wheels in proper alignment.
- Avoid carrying unnecessary luggage or cargo.
- The indication of the ECO gauge shows a reference for saving fuel. For details, refer to "ECO gauge" 3-8.

Engine exhaust gas (carbon monoxide)



WARNING

- **Never inhale engine exhaust gas. Engine exhaust gas contains carbon monoxide, a colorless and odorless gas which is dangerous, or even lethal, if inhaled.**
- **Always properly maintain the engine exhaust system to prevent engine exhaust gas from entering the vehicle.**
- **Never run the engine in a closed space, such as a garage, except for the brief time needed to drive the vehicle in or out of it.**
- **Avoid remaining in a parked vehicle for a long time while the engine is running. If that is unavoidable, then use the ventilation fan to force fresh air into the vehicle.**
- **Always keep the front ventilator inlet grille free from snow, leaves or other obstructions to ensure that the ventilation system always works properly.**
- **If at any time you suspect that**

exhaust fumes are entering the vehicle, have the problem checked and corrected as soon as possible. If you must drive under these conditions, drive only with all windows fully open.

- Keep the trunk lid (Legacy) or rear gate (Outback) closed while driving to prevent exhaust gas from entering the vehicle.

NOTE

Due to the expansion and contraction of the metals used in the manufacture of the exhaust system, you may hear a crackling sound coming from the exhaust system for a short time after the engine has been shut off. This sound is normal.

Catalytic converter

⚠ WARNING

- Avoid fire hazards. Do not drive or park the vehicle anywhere near flammable materials (e.g. grass, paper, rags or leaves), because the catalytic converter operates at very high temperatures.
- Keep everyone and flammable materials away from the exhaust pipe while the engine is running. The exhaust gas is very hot.

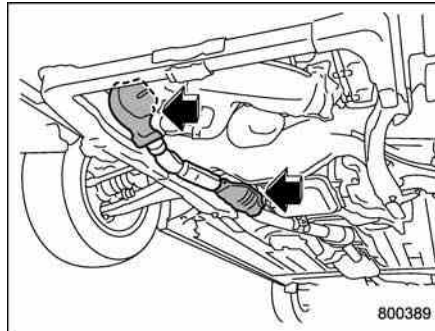

2.5 L non-turbo models

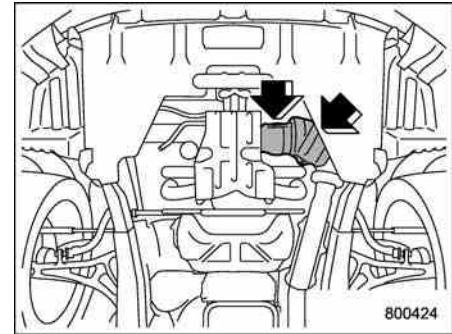

2.5 L turbo models

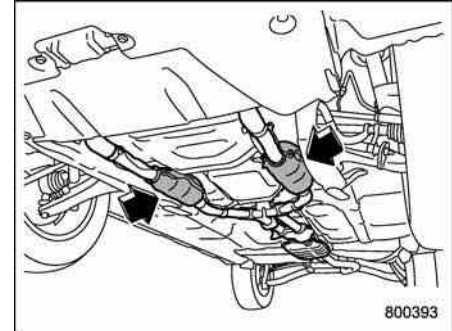

3.6 L models

The catalytic converter is installed in the exhaust system. It serves as catalyst to reduce HC, CO and NOx in exhaust gases, thus providing cleaner exhaust.

To avoid damage to the catalytic converter:

- Use only unleaded gasoline. Even a small amount of leaded gasoline will damage the catalytic converter.
- Never start the engine by pushing or pulling the vehicle.
- Avoid racing the engine.
- Never turn off the ignition switch while the vehicle is moving.
- Keep your engine tuned-up. If you feel the engine running rough (misfiring, backfiring or incomplete combustion), have your vehicle checked and repaired by an authorized SUBARU dealer.
- Do not apply undercoating or rust prevention treatment to the heat shield of catalytic converter and the exhaust system.
- Do not drive with an extremely low fuel level.

Periodic inspections

To keep your vehicle in the best condition at all times, always have the recommended maintenance services listed in the maintenance schedule in the “Warranty and Maintenance Booklet” performed at the specified time or mileage intervals.

Driving in foreign countries

When planning to use your vehicle in another country:

- Confirm the availability of the correct fuel. Refer to “Fuel requirements” 7-2.
- Comply with all regulations and requirements of each country.

Driving tips for AWD vehicles

WARNING

- Always maintain a safe driving speed according to the road and weather conditions in order to avoid having an accident on a sharp turn, during sudden braking or under other similar conditions.
- Always use the utmost care in driving – overconfidence because you are driving an All-Wheel Drive vehicle could easily lead to a serious accident.
- When replacing a tire, you must use a tire that is of the same size, circumference, construction, brand (tread pattern), speed symbol and load index as the original tires listed on the tire placard. Using tires of other sizes, circumferences or constructions may result in severe mechanical damage to the drive train of your vehicle and may affect ride, handling, braking, speedometer/odometer calibration, and clearance between the body and tires. It also may be dangerous and

lead to loss of vehicle control.

- You must install four tires that are of the same size, circumferences, construction, manufacturer, brand (tread pattern), degree of wear, speed symbol and load index. Mixing tires of other sizes, circumferences or constructions may result in severe mechanical damage to the drive train of your vehicle and may affect ride, handling, braking and speedometer/odometer calibration. It also may be dangerous and lead to loss of vehicle control.

CAUTION

If you use a temporary spare tire to replace a flat tire, be sure to use the original temporary spare tire stored in the vehicle. Using other sizes may result in severe mechanical damage to the drive train of your vehicle.

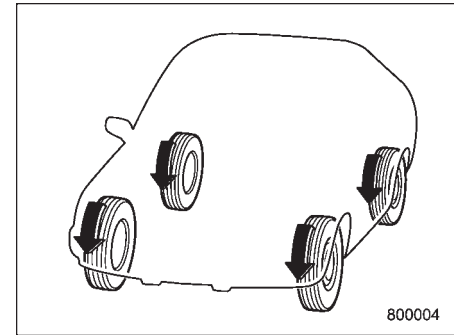

All-Wheel Drive distributes the engine power to all four wheels. AWD vehicles provide better traction when driving on slippery, wet or snow-covered roads and when moving out of mud, dirt and sand. By shifting power between the front and rear wheels, SUBARU AWD can also provide added traction during acceleration, and added engine braking force during deceleration.

Therefore, your SUBARU AWD vehicle may handle differently than an ordinary two wheel drive vehicle and it contains some features unique to AWD. For safety purposes as well as to avoid damaging the AWD system, you should keep the following tips in mind:

- An AWD vehicle is better able to climb steeper roads under snowy or slippery

conditions than a two wheel drive vehicle. There is little difference in handling, however, during extremely sharp turns or sudden braking. Therefore, when driving down a slope or turning corners, be sure to reduce your speed and maintain an ample distance from other vehicles.

- Always check the cold tire pressure before starting to drive. The recommended tire pressure is provided on the tire placard, which is located on the door pillar on the driver's side.

- There are some precautions that you must observe when towing your vehicle. For detailed information, refer to "Towing" 9-13.

Off road driving



WARNING

- **Always maintain a safe driving speed according to the road and weather conditions in order to avoid having an accident on a sharp turn, during sudden braking or under other similar conditions.**
- **Always use the utmost care in driving – overconfidence because you are driving an All-Wheel Drive vehicle could easily lead to a serious accident.**

■ Legacy

Your AWD vehicle is neither a conventional off-road vehicle nor an all terrain vehicle. It is a passenger car designed primarily for on-road use. The AWD feature gives it some limited off-road capabilities in situations in which the driving surface is relatively level, obstruction-free and otherwise similar to on-road driving conditions. Operating it under other than those conditions could subject the vehicle to excessive stress which might result in damage not eligible for repair

under warranty. If you do take your SUBARU off road, you should review the common sense precautions in the next section (applicable to the Outback) for general guidance. But please keep in mind that your vehicle's off-road capabilities are more limited than those of the Outback.

Never attempt to drive through pools and puddles, or roads flooded with water. Water entering the engine air intake or the exhaust pipe or water splashing onto electrical parts may damage your vehicle and may cause it to stall.

■ Outback

Because of the AWD feature and higher ground clearance, your SUBARU can be driven on ordinary roads or off-road. But please keep in mind that an AWD SUBARU is a passenger car and is neither a conventional off-road vehicle nor an all-terrain vehicle. If you do take your SUBARU off-road, certain common sense precautions such as those in the following list should be taken:

- Make certain that you and all of your passengers are wearing seatbelts.
- Carry some emergency equipment, such as a towing rope or chain, a shovel, wheel blocks, first aid kit and cell phone or citizens band radio.

- Drive carefully. Do not take unnecessary risks by driving in dangerous areas or over rough terrain.
- Slow down and employ extra caution at all times. When driving off-road, you will not have the benefit of marked traffic lanes, banked curves, traffic signs and the like.
- Do not drive across steep slopes. Instead, drive either straight up or straight down the slopes. A vehicle can much more easily tip over sideways than it can end over end. Avoid driving straight up or down slopes that are too steep.
- Avoid sharp turning maneuvers, especially at higher speeds.
- Do not grip the inside or spokes of the steering wheel. A bad bump could jerk the wheel and injure your hands. Instead drive with your fingers and thumbs on the outside of the rim.
- If driving through water, such as when crossing shallow streams, first check the depth of the water and the bottom of the stream bed for firmness and ensure that the bed of the stream is flat. Drive slowly and completely through the stream. The water should be shallow enough that it does not reach the vehicle's undercarriage. Water entering the engine air intake or the exhaust pipe or water splashing onto electrical parts may damage your

vehicle and may cause it to stall. Never attempt to drive through rushing water; regardless of its depth, it can wash away the ground from under your tires, resulting in possible loss of traction and even vehicle rollover.

- Always check your brakes for effectiveness immediately after driving in sand, mud or water. Do this by driving slowly and stepping on the brake pedal. Repeat that process several times to dry out the brake discs and brake pads.
- Do not drive or park over or near flammable materials such as dry grass or fallen leaves, as they may burn easily. The exhaust system is very hot while the engine is running and right after the engine stops. This could create a fire hazard.
- After driving through tall grass, mud, rocks, sand, rivers, etc., check that there is no grass, bush, paper, rags, stones, sand, etc. adhering to or trapped on the underbody. Clear off any such matter from the underbody. If the vehicle is used with these materials trapped or adhering to the underbody, a mechanical breakdown or fire could occur.
- Secure all cargo carried inside the vehicle and make certain that it is not piled higher than the seatbacks. During sudden stops or jolts, unsecured cargo

could be thrown around in the vehicle and cause injury. Do not pile heavy loads on the roof. Those loads raise the vehicle's center of gravity and make it more prone to tip over.

- If you must rock the vehicle to free it from sand or mud, depress the accelerator pedal slightly and move the shift lever/ select lever back and forth between "1"/ "D" and "R" repeatedly. Do not race the engine. For the best possible traction, avoid spinning the wheels when trying to free the vehicle.
- When the road surface is extremely slippery, you can obtain better traction by starting the vehicle with the transmission in 2nd than 1st (both for MT, AT and CVT). For AT and CVT models, refer to "Selection of manual mode" 7-21.
- Never equip your vehicle with tires larger than those specified in this manual.
- Wash the vehicle's underbody after off-road driving. Suspension components are particularly prone to dirt buildup, so they need to be washed thoroughly.
- Frequent driving of an AWD vehicle under hard-driving conditions such as rough roads or off roads will necessitate more frequent replacement of engine oil, brake fluid and transmission oil than that specified in the maintenance schedule described in the "Warranty and Maintenance" section.

nance Booklet”.

Remember that damage done to your SUBARU while operating it off-road and not using common sense precautions such as those listed above is not eligible for warranty coverage.

Winter driving



■ Operation during cold weather

Carry some emergency equipment, such as a window scraper, a bag of sand, flares, a small shovel and jumper cables.

Check the battery and cables. Cold temperatures reduce battery capacity. The battery must be in good condition to provide enough power for cold winter starts.

It normally takes longer to start the engine in very cold weather conditions. Use an engine oil of a proper grade and viscosity for cold weather. Using heavy summer oil will make it harder to start the engine.

Keep the door locks from freezing by squirting them with deicer or glycerin.

Forcing a frozen door open may damage or separate the rubber weather strips around the door. If the door is frozen, use hot water to melt the ice, and afterwards thoroughly wipe the water away.

Use a windshield washer fluid that contains an antifreeze solution. Do not use engine antifreeze or other substitutes because they may damage the paint of the vehicle.

SUBARU Windshield Washer Fluid contains 58.5% methyl alcohol and 41.5% surfactant, by volume. Its freezing temperature varies according to how much it is diluted, as indicated in the following table.

Washer Fluid Concentration	Freezing Temperature
30%	10.4°F (-12°C)
50%	-4°F (-20°C)
100%	-49°F (-45°C)

In order to prevent freezing of washer fluid, check the freezing temperatures in the table above when adjusting the fluid concentration to the outside temperature. If you fill the reservoir tank with a fluid with

a different concentration from the one used previously, purge the old fluid from the piping between the reservoir tank and washer nozzles by operating the washer for a certain period of time. Otherwise, if the concentration of the fluid remaining in the piping is too low for the outside temperature, it may freeze and block the nozzles.

 **CAUTION**

- **Adjust the washer fluid concentration appropriately for the outside temperature. If the concentration is inappropriate, sprayed washer fluid may freeze on the windshield and obstruct your view, and the fluid may freeze in the reservoir tank.**
- **State or local regulations on volatile organic compounds may restrict the use of methanol, a common windshield washer antifreeze additive. Washer fluids containing non-methanol antifreeze agents should be used only if they provide cold weather protection without damaging your vehicle's paint, wiper blades or washer system.**

▼ **Before driving your vehicle**

Before entering the vehicle, remove any snow or ice from your shoes because that could make the pedals slippery and driving dangerous.

While warming up the vehicle before driving, check that the accelerator pedal, brake pedal, and all other controls operate smoothly.

Clear away ice and snow that has accumulated under the fenders to avoid making steering difficult. During severe winter driving, stop when and where it is safe to do so and check under the fenders periodically.

▼ **Parking in cold weather**

 **WARNING**

Snow can trap dangerous exhaust gases under your vehicle. Keep snow clear of the exhaust pipe and from around your vehicle if you park the vehicle in snow with the engine running.

Do not use the parking brake when parking for long periods in cold weather since it could freeze in that position. Instead, you should observe the following tips.

1. Place the shift lever in "1" or "R" for MT models, or the select lever in "P" for AT models and CVT models.
2. Use tire stops under the tires to prevent the vehicle from moving.

When the vehicle is parked in snow or when it snows, raise the wiper blades off the glass to prevent damage to them.

When the vehicle has been left parked after use on roads heavily covered with snow, or has been left parked during a snowstorm, icing may develop on the brake system, which could cause poor braking action. Check for snow or ice buildup on the suspension, disc brakes and brake hoses underneath the vehicle. If there is caked snow or ice, remove it, being careful not to damage the disc brakes and brake hoses and ABS harness.

▼ **Refueling in cold weather**

To help prevent moisture from forming in the fuel system and the risk of its freezing, use of an antifreeze additive in the fuel tank is recommended during cold weather. Use only additives that are specifically designed for this purpose. When an antifreeze additive is used, its effect lasts longer if the tank is refilled whenever the fuel level reaches half empty.

If your SUBARU is not going to be used for an extended period, it is best to have the fuel tank filled to capacity.

■ Driving on snowy and icy roads



WARNING

Do not use the cruise control on slippery roads such as snowy or icy roads. This may cause loss of vehicle control.



CAUTION

Avoid prolonged continuous driving in snowstorms. Snow will enter the engine's intake system and may hinder the airflow, which could result in engine shutdown or even breakdown.

To prevent skidding and slipping, avoid sudden braking, abrupt acceleration, high-speed driving, and sharp turning when driving on snowy or icy roads.

Always maintain ample distance between your vehicle and the vehicle ahead of you to avoid the need for sudden braking.

To supplement the foot brake, use the engine brake effectively to control the

vehicle speed. (Shift into a lower gear when necessary.)

Avoid shifting down abruptly. Such behavior can cause the wheels to lock, possibly leading to loss of vehicle control.

An anti-lock brake system (ABS) enhances your vehicle's braking performance on snowy and icy roads. For information about braking on slippery surfaces, refer to "ABS (Anti-lock Brake System)" 7-24 and "Vehicle Dynamics Control system" 7-26.

▼ Wiper operation when snowing

Before driving in cold weather, make sure the wiper blades are not frozen to the windshield or rear window.

If the wiper blades are frozen to the windshield or rear window, perform the following procedure.

- To thaw the windshield wiper blades, use the defroster with the airflow selection in "☐" and the temperature set for maximum warmth until the wiper blades are completely thawed. Refer to "Climate control" 4-1.
- If your vehicle is equipped with a wiper deicer, use it. It is helpful to thaw the windshield wiper blades. Refer to "Defogger and deicer" 3-34.
- To thaw the rear wiper blade, use the

rear window defogger. Refer to "Defogger and deicer" 3-34.

When driving in snow, if frozen snow starts to stick on the surface of the windshield despite wiper operation, use the defroster with the airflow selection in "☐" and the temperature set for maximum warmth. After the windshield gets warmed enough to melt the frozen snow on it, wash it away using the windshield washer. Refer to "Windshield washer" 3-32.

Snow stuck on the wiper arm prevents the wiper from working effectively. If snow is stuck on the wiper arm, pull off the road to a safe place, then remove it. If you stop the vehicle at road side, use the hazard warning flasher to alert other drivers. Refer to "Hazard warning flasher" 3-5.

We recommend use of non-freezing type wiper blades (winter blades) during the seasons you could have snow and freezing temperatures. Blades of this type give superior wiping performance in snowy conditions. Be sure to use blades that are suitable for your vehicle.



CAUTION

During high-speed driving, non-freezing type wiper blades may not perform as well as standard wiper

blades. If this happens, reduce the vehicle speed.

NOTE

When the season requiring non-freezing type wiper blades is over, replace them with standard wiper blades.

■ Corrosion protection

Refer to “Corrosion protection” 10-4.

■ Snow tires



WARNING

- When replacing original tires with winter (snow) tires, make sure you use only tires of the same size, circumference, construction, brand (tread pattern), speed symbol and load index as the original tires listed on the tire placard. Using tires of other sizes and constructions may affect speedometer/odometer calibration and clearance between the body and tires. It also may be dangerous and lead to loss of vehicle control.
- You must install four winter tires

that are of the same size, circumference, construction, manufacturer, brand (tread pattern), degree of wear, speed symbol and load index. Mixing tires of other sizes or constructions may result in severe mechanical damage to the drive train of your vehicle and may affect ride, handling, braking and speedometer/odometer calibration. It also may be dangerous and lead to loss of vehicle control.

- Do not use a combination of radial, belted bias or bias tires since it may cause dangerous handling characteristics and lead to an accident.

▼ Except 2.5 L turbo models

Your vehicle is equipped with “all season tires” which are designed to provide an adequate measure of traction, handling and braking performance in year-round driving. In winter, it may be possible to enhance performance through use of tires designed specifically for winter driving conditions.

If you choose to install winter tires on your vehicle, be sure to use the correct tire size and type. You must install four winter tires

that are of the same size, construction, brand and load range and you should never mix radial, belted bias or bias tires since this may result in dangerous handling characteristics. When you choose a tire, make sure that there is enough clearance between the tire and vehicle body.

Remember to drive with care at all times regardless of the type of tires on your vehicle.

▼ 2.5 L turbo models

Your vehicle is equipped with “summer tires” as original equipment, which are inadequate for driving on slippery roads such as on snow-covered or icy roads.

Compared with winter and all-season tires, summer tires give significantly less grip on snowy and icy road surfaces. Therefore, use of winter tires is strongly recommended when driving with such road conditions.

When you choose to install winter tires on your vehicle, be sure to use the correct tire size and type. You must install four winter tires that are of the same size, construction, brand and load range and you should never mix radial, belted bias or bias tires since this may result in dangerous handling characteristics. When you choose a tire, make sure that there is enough

clearance between the tire and vehicle body.

Remember to drive with care at all times regardless of the type of tires on your vehicle.

■ Tire chains

CAUTION

Tire chains cannot be used on your vehicle because of the lack of clearance between the tires and vehicle body.

NOTE

When tire chains cannot be used, use of another type of traction device (such as spring chains) may be acceptable if use on your vehicle is recommended by the device manufacturer, taking into account tire size and road conditions. Follow the device manufacturer's instructions, especially regarding maximum vehicle speed.

To help avoid damage to your vehicle, drive slowly, readjust or remove the device if it is contacting your vehicle, and do not spin your wheels. Damage caused to your vehicle by use of a traction device is not covered under

warranty.

Make certain that any traction device you use is an SAE class S device, and use it on the front wheels only. Always use the utmost care when driving with a traction device. Overconfidence because you are using a traction device could easily lead to a serious accident.

■ Rocking the vehicle

If you must rock the vehicle to free it from snow, sand, or mud, depress the accelerator pedal slightly and move the shift lever/select lever back and forth between "1"/"D" and "R" repeatedly. Do not race the engine. For the best possible traction, avoid spinning the wheels when trying to free the vehicle.

When the road surface is extremely slippery, you can obtain better traction by starting the vehicle with the transmission in 2nd than 1st (for MT, AT and CVT).

For information on holding the transmission in 2nd position, refer to "Selection of manual mode" 7-21.

Loading your vehicle

WARNING

Never allow passengers to ride on a folded rear seatback, in the trunk or in the cargo area. Doing so may result in serious injury.

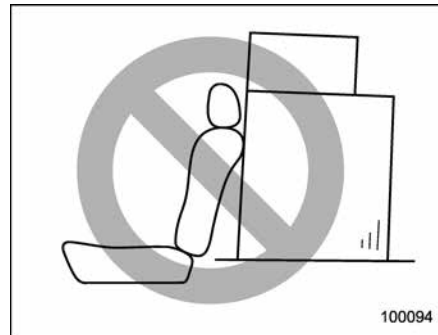

WARNING

- Never stack luggage or other cargo higher than the top of the seatback because it could tumble forward and injure passengers in the event of a sudden stop or accident. Keep luggage or cargo low, as close to the floor as

possible.

- When you carry something inside the vehicle, secure it whenever you can to prevent it from being thrown around inside the vehicle during sudden stops, sharp turns or in an accident.
- Do not pile heavy loads on the roof. These loads raise the vehicle's center of gravity and make it more prone to tip over.
- Secure long items properly to prevent them from shooting forward and causing serious injury during a sudden stop.
- Never exceed the maximum load limit. If you do, some parts on your vehicle can break, or it can change the way your vehicle handles. This could result in loss of control and cause personal injury. Also, overloading can shorten the life of your vehicle.
- Do not place anything on the rear shelf behind the rear seatback (Legacy) or the extended cargo area cover (Outback). Such items could tumble forward in the event of a sudden stop or a collision. This could cause serious injury.



CAUTION

Do not carry spray cans, containers with flammable or corrosive liquids or any other dangerous items inside the vehicle.

NOTE

For better fuel economy, do not carry unneeded cargo.

■ Vehicle capacity weight

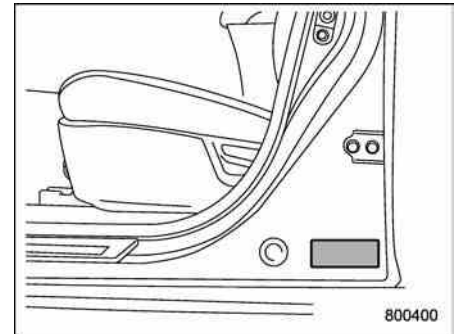
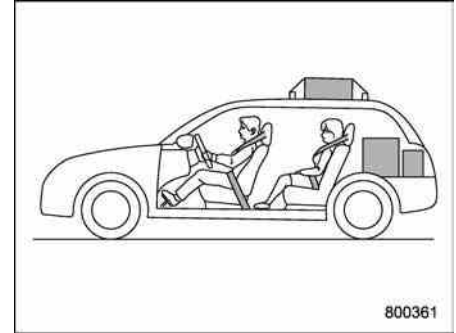

The load capacity of your vehicle is determined by weight, not by available cargo space. The maximum load you can carry in your vehicle is shown on the vehicle placard attached to the driver's

side door pillar. It includes the total weight of the driver and all passengers and their belongings, any optional equipment such as a trailer hitch, roof rack or bike carrier, etc., and the tongue load of a trailer.

■ GVWR and GAWR (Gross Vehicle Weight Rating and Gross Axle Weight Rating)

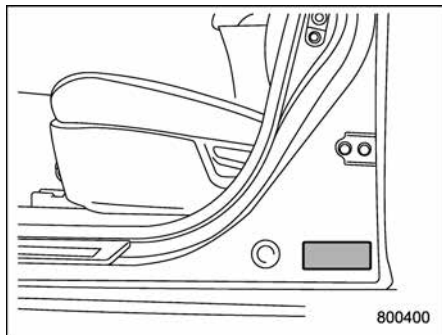

Certification label

The certification label attached to the driver's side door shows GVWR (Gross Vehicle Weight Rating) and GAWR (Gross Axle Weight Rating).

The GVW (Gross Vehicle Weight) must never exceed the GVWR. GVW is the combined total of weight of the vehicle, fuel, driver, all passengers, luggage, any optional equipment and trailer tongue

load. Therefore, the GVW changes depending on the situation.

In addition, the total weight applied to each axle (GAW) must never exceed the GAWR. The front and rear GAWs can be adjusted by relocating luggage inside the vehicle.

Even if the total weight of your luggage is lower than the vehicle capacity weight, either front or rear GAW may exceed the GAWR, depending on the distribution of the luggage.

When possible, the load should be evenly distributed throughout the vehicle.

If you carry heavy loads in the vehicle, you should confirm that GVW and front and rear GAWs are within the GVWR and GAWR by putting your vehicle on a vehicle scale, found at a commercial weighing station.

Do not use replacement tires with a lower load range than the originals because they may lower the GVWR and GAWR limitations. Replacement tires with a higher load range than the originals do not increase the GVWR and GAWR limitations.

■ Roof rails with integrated crossbars (Outback)

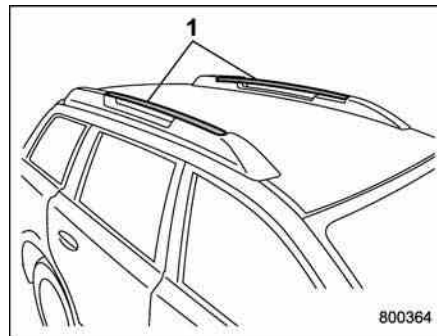

1) Integrated crossbars



CAUTION

- For cargo carrying purposes, the bars must be used as crossbars and be used together with the genuine SUBARU carrying attachment. The bars must never be used alone to carry cargo. Otherwise, damage to the roof or paint or a dangerous road hazard due to loss of cargo could result.
- When using the bars as crossbars, make sure that the total weight of the carrying attachment and cargo does not exceed

the maximum load limit. Overloading may cause damage to the vehicle and create a safety hazard.

The bars can be used as crossbars. Cargo can be carried after setting the bars as crossbars and installing the genuine SUBARU carrying attachment.

When you carry cargo on the roof using the crossbars and a carrying attachment, never exceed the maximum load limit explained in the following. You should also be careful that your vehicle does not exceed the Gross Vehicle Weight Rating (GVWR) and front and rear Gross Axle Weight Rating (GAWR). For information on loading cargo into or onto your vehicle, refer to "Loading your vehicle" 8-12. The maximum load limit of the cargo and carrying attachment must not exceed the allowable load limit described in the Owner's Manual of a genuine SUBARU carrying attachment. Place the heaviest load at the bottom, nearest the roof, and evenly distribute the cargo. Always properly secure all cargo.

▼ Installing carrying attachments on the crossbars

When installing any carrying attachment such as a bike carrier, ski carrier, kayak carrier, cargo basket, etc. on the crossbars, follow the manufacturer's instructions and make sure that the attachment is securely fixed to the crossbars. Use only attachments designed specifically for the crossbars. A set of the crossbars is designed to carry loads (cargo and attachment) of not more than the allowable load limit described in the Owner's Manual of a genuine SUBARU carrying attachment. Before operating the vehicle, make sure that the cargo is properly secured on the attachment.

NOTE

- Remember that the vehicle's center of gravity is altered with the weight of the load on the roof, thus affecting the driving characteristics. Drive carefully, avoid rapid starts, hard cornering and abrupt stops. Crosswind effects will be increased.
- Restore the bars to the original position when the bars are not used as crossbars.

▼ How to use as crossbars



CAUTION

- Do not raise the bar higher than necessary. The base of the bar may be damaged.
- Be careful not to contact the bars while sliding them. Otherwise, the bars may be scratched or the latch portions may be damaged.
- Do not slide the bar more than necessary when sliding the bar. The base of the bar may be damaged.
- Do not allow the bar to fall on or contact the roof panel or the moonroof when sliding the bar. Otherwise the roof panel may be dented or the glass of the moonroof may be damaged.



1. Pull out the integrated crossbars from the roof rail holders by pulling up the covers.

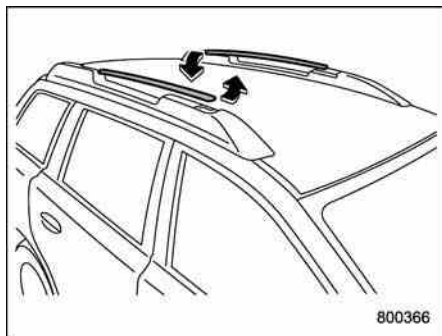

2. Slide the bars in the direction shown in the illustration.

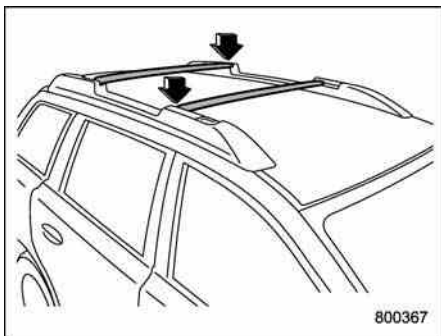

3. Install the bars into the holders.
4. Make sure that the latches are fitted securely.

▼ **How to re-stow bars**



Do not use the bars as roof rails when the bars are stowed.

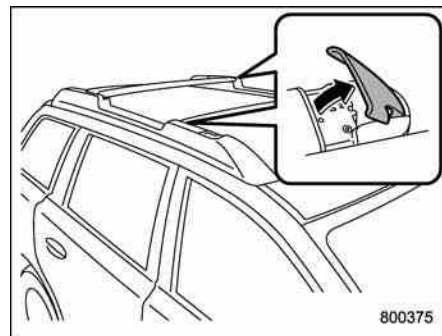

1. Pull out the crossbars from the roof rail holders by pulling up the covers.

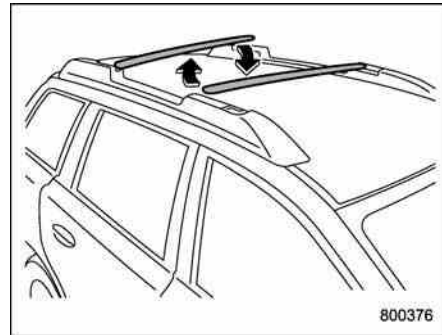

2. Slide the bars in the direction shown in the illustration.

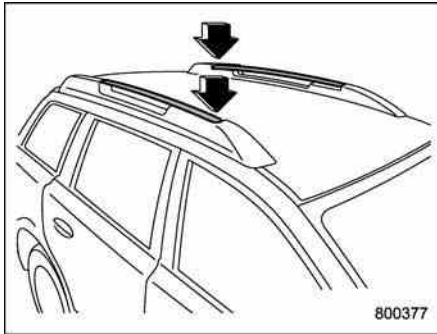

3. Install the bars into the holders.
4. Make sure that the latches are fitted securely.

Trailer hitch (Outback — if equipped)

WARNING

- Never exceed the maximum weight specified for the trailer hitch. Exceeding the maximum weight could cause an accident resulting in serious personal injuries. Permissible trailer weight changes depending on the situation. For possible recommendations and limitations, refer to “Trailer towing” 8-19.
- Trailer brakes are required when the towing load exceeds 1,000 lbs (453 kg). Be sure your trailer has safety chains and that each chain will hold the trailer’s maximum gross weight. Towing trailers without safety chains could create a traffic safety hazard if the trailer separates from the hitch due to coupling damage or hitch ball damage.
- Be sure to check the hitch pin and safety pin for positive locking placement before towing a trailer. If the ball mount comes off the hitch receiver, the trailer

could get loose and create a traffic safety hazard.

- Use only the ball mount supplied with this hitch. Use the hitch only as a weight carrying hitch. Do not use with any type of weight distributing hitch.

The trailer hitch is designed to tow a Class 1 rated load. The maximum gross trailer weight and maximum gross tongue weight are indicated in the following table.

	Maximum gross trailer weight	Maximum gross tongue weight
3.6 L models	3,000 lbs (1,360 kg)	200 lbs (90 kg)
All models other than 3.6 L models	2,700 lbs (1,224 kg)	

When you tow a trailer, refer to “Trailer towing” 8-19.

■ Connecting a trailer

1. Remove the receiver cover from the hitch receiver tube. Then insert the ball mount into the hitch receiver tube.

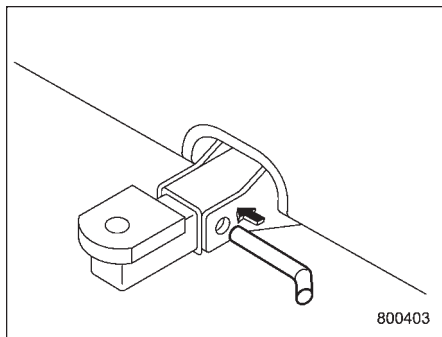

2. Insert the hitch pin into the hole on the ball mount so that the pin passes through the ball mount.

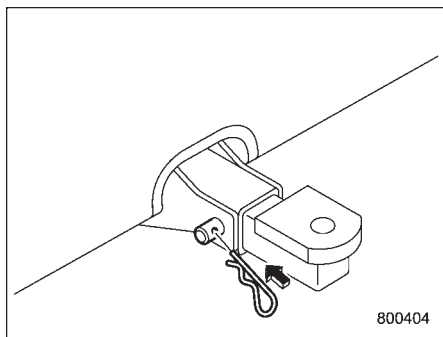

3. Insert the safety pin onto the hitch pin securely.

4. Pull the ball mount to make sure it does not come off the hitch receiver.

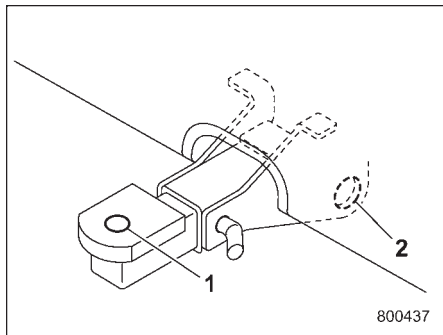

- 1) Hitch ball installation point
- 2) Hooks for safety chains

5. Use only a hitch ball that is appropriate for the ball mount and your trailer. The hitch ball must be securely installed on the ball mount.

6. Connect your trailer to the hitch ball.

7. Connect the trailer and the hitch with safety chains that will hold the trailer's maximum gross weight. The chains should cross under the trailer tongue to prevent the tongue from dropping onto the ground in case it should disconnect from the hitch ball. Allow sufficient slack in the chains taking tight turn situations into account; however, be careful not to let them drag on the ground.



WARNING

Do not connect safety chains to part of the vehicle other than the safety chain hooks.

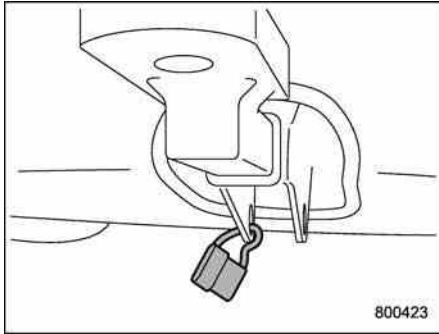

Hitch harness connector

8. Connect the hitch wire harness's black four-pin wire connector to the towing trailer's wire harness.

9. Confirm proper function of the hitch wire harness by individually activating the brake, stop and turn signal lights on the trailer.

NOTE

Always disconnect the trailer wire harness before launching or retrieving a watercraft.

■ **When you do not tow a trailer**

- Remove the ball mount from the hitch receiver tube and insert the receiver cover onto the hitch receiver tube.
- Place the dust cap over the four-pin connector of the hitch wire harness to protect against possible damage.
- Occasionally lubricate terminals of the four-pin connector using terminal grease.

Trailer towing

Your vehicle is designed and intended to be used primarily as a passenger-carrying vehicle. Towing a trailer puts additional loads on your vehicle's engine, drivetrain, brakes, tires and suspension and has an adverse effect on fuel economy.

If you do decide to tow a trailer, your safety and satisfaction depend upon proper use of correct equipment and cautious operation of your vehicle. Seek the advice of your SUBARU dealer to assist you in purchasing a hitch and other necessary towing equipment appropriate for your vehicle. In addition, be sure to follow the instructions on correct installation and use provided by the trailer and other towing equipment manufacturers.

SUBARU assumes no responsibility for injuries or vehicle damage that result from trailer towing equipment, or from any errors or omissions in the instructions accompanying such equipment or for your failure to follow the proper instructions.

■ **Warranties and maintenance**

SUBARU warranties do not apply to vehicle damage or malfunction caused by trailer towing. If you use your vehicle to tow a trailer, more frequent maintenance will be required due to the additional load.

(Refer to “Maintenance schedule under severe driving conditions” in the “Warranty and Maintenance Booklet”.)

Under no circumstances should a trailer be towed with a new vehicle or a vehicle with any new powertrain component (engine, transmission, differential, wheel bearings, etc.) for the first 1,000 miles (1,600 km) of driving.

■ Maximum load limits



WARNING

Never exceed the maximum load limits explained in the following. Exceeding the maximum load limits could cause personal injury and/or vehicle damage.



CAUTION

- **Adequate size trailer brakes are required when the trailer and its cargo exceed 1,000 lbs (453 kg) total weight.**
- **Before towing a trailer, check the trailer total weight, GVW, GAWs and tongue load. Make sure the load and its distribution in your vehicle and trailer are accepta-**

ble.

▼ **Total trailer weight**

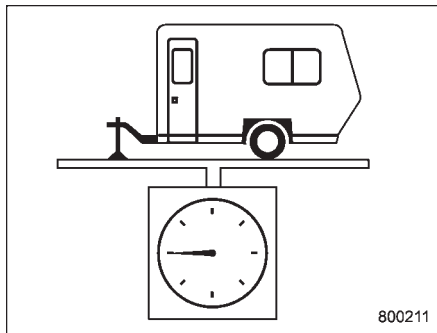

Total trailer weight

The total trailer weight (trailer weight plus its cargo load) must never exceed the maximum weight.

▽ **Legacy**

The total trailer weight must not exceed 1,000 lbs (453 kg).

▽ **Outback**

The maximum total trailer weight is indicated in the following tables.

3.6 L models

Conditions	Maximum total trailer weight
When towing a trailer without brakes.	1,000 lbs (453 kg)
When towing a trailer with brakes.	3,000 lbs (1,360 kg)
When towing a trailer on a long uphill grade continuously for over 5 miles (8 km) with an outside temperature of 104°F (40°C) or above.	1,500 lbs (680 kg)

All models other than 3.6 L models

Model	Conditions	Maximum total trailer weight
MT models	When towing a trailer without brakes.	1,000 lbs (453 kg)
	When towing a trailer with brakes.	2,700 lbs (1,224 kg)
CVT models	When towing a trailer without brakes.	1,000 lbs (453 kg)
	When towing a trailer with brakes.	2,700 lbs (1,224 kg)
	When towing a trailer on a long uphill grade continuously for over 5 miles (8 km) with an outside temperature of 104°F (40°C) or above.	1,350 lbs (612 kg)

▼ **Gross Vehicle Weight (GVW) and Gross Vehicle Weight Rating (GVWR)**

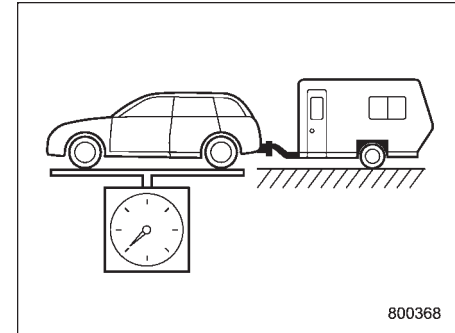

Gross Vehicle Weight

The Gross Vehicle Weight (GVW) must never exceed the Gross Vehicle Weight Rating (GVWR).

Gross Vehicle Weight (GVW) is the combined total of the weight of the vehicle, driver, passengers, luggage, trailer hitch, trailer tongue load and any other optional equipment installed on your vehicle. Therefore, the GVW changes depending on the situation. Determine the GVW each time before going on a trip by putting your vehicle and trailer on a vehicle scale.

GVWR is shown on the certification label located on the driver's door of your vehicle.

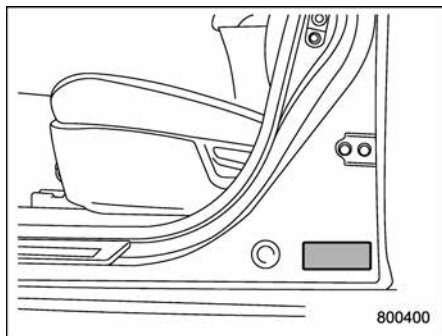

Certification label

▼ **Gross Axle Weight (GAW) and Gross Axle Weight Rating (GAWR)**

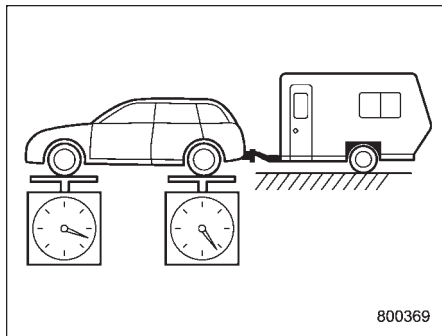

Gross Axle Weight

The total weight applied to each axle (GAW) must never exceed the Gross Axle Weight Rating (GAWR). The front and rear GAWs can be adjusted by relocating passengers and luggage inside the vehicle. The front and rear GAWR are also shown on the certification label.

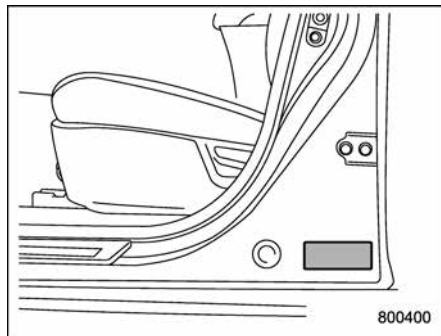

Certification label

To check both GVWR and GAWR and to confirm that the total weight and weight distribution are within safe driving limits, you should have your vehicle and trailer weighed at a commercial weighing station. Be sure that all cargo is firmly secured to prevent a change in weight distribution while driving.

▼ **Tongue load**

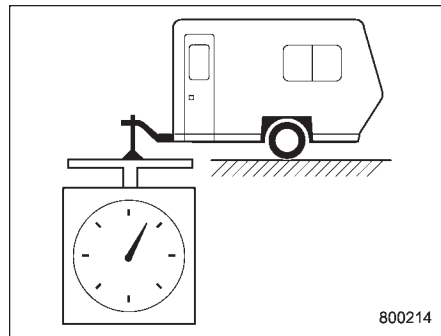

Tongue load

▲ WARNING

If the trailer is loaded with more weight in the back of trailer's axle than in the front, the load is taken off the rear axle of the towing vehicle. This may cause the rear wheels to skid, especially during braking or when vehicle speed is reduced during cornering, resulting in oversteer, spin out and/or jackknifing.

Ensure that the trailer tongue load is from 8 to 11 percent of the total trailer weight and does not exceed the maximum value of 200 lbs (90 kg).

NOTE

For vehicles with trailer brakes, the trailer tongue load exceeds 200 lbs (90 kg) when calculated at 8% of the maximum total trailer weight.

Even in this case, the maximum value is 200 lbs (90 kg).

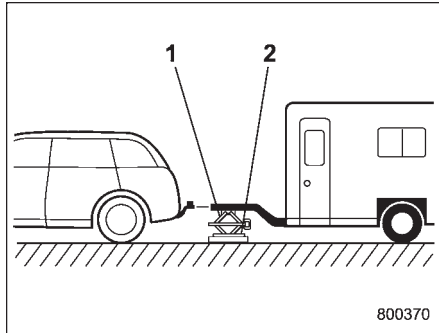

- 1) Jack
- 2) Bathroom scale

The tongue load can be weighed with a bathroom scale as shown in the following illustration. When weighing the tongue load, be sure to position the towing coupler at the height at which it would be during actual towing, using a jack as shown.

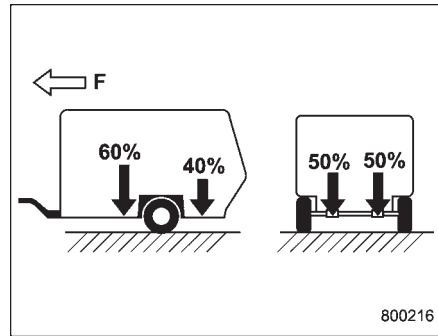

F: Front

The tongue load can be adjusted by proper distribution of the load in the trailer. Never load the trailer with more weight in the back than in the front; approximately 60 percent of the trailer load should be in the front and approximately 40 percent in the rear. Also, distribute the load as evenly as possible on both the left and right sides.

Be sure that all cargo is firmly secured to prevent a change in weight distribution while driving.

Trailer hitches**WARNING**

Never drill the frame or under-body of your vehicle to install a commercial trailer hitch. If you do, dangerous exhaust gas, water or mud may enter the passenger compartment through the drilled hole. Exhaust gas contains carbon monoxide, a colorless and odorless gas which is dangerous, or even lethal, if inhaled. Also, drilling the frame or under-body of your vehicle could cause deterioration of strength of your vehicle and cause corrosion around the drilled hole.

CAUTION

- Do not modify the vehicle exhaust system, brake system, or other systems when installing a hitch or other trailer towing equipment.
- Do not use axle-mounted hitches as they can cause damage to the axle housing, wheel bearings, wheels or tires.

Choose a proper hitch for your vehicle and

– CONTINUED –

trailer.

▼ **Outback**

The use of a genuine SUBARU trailer hitch is recommended. A genuine SUBARU hitch is available from your SUBARU dealer.

If use of a non-genuine hitch is unavoidable, be sure the hitch is suited to your vehicle and trailer. Consult with a professional hitch supplier to assist you in choosing an appropriate hitch for your vehicle. Be sure to follow all of the hitch manufacturer's instructions for installation and use.

Never use a hitch that mounts only to the rear bumper. The bumper is not designed to handle that type of load.

For all types of hitches, regularly check that the hitch mounting bolts and nuts are tight.

▼ **Legacy**

SUBARU does not offer accessory trailer hitches. Consult with a professional hitch supplier to assist you in choosing an appropriate hitch for your vehicle. Be sure to follow all of the hitch manufacturer's instructions for installation and use.

Never use a hitch that mounts only to the rear bumper. The bumper is not designed to handle that type of load.

Regularly check that the hitch mounting bolts and nuts are tight.

■ **Connecting a trailer**

▼ **Trailer brakes**

 **WARNING**

- **Adequate size trailer brakes are required when the trailer and its cargo exceed 1,000 lbs (453 kg) total weight.**
- **Do not directly connect your trailer's hydraulic brake system to the hydraulic brake system in your vehicle. Direct connection would cause the vehicle's brake performance to deteriorate and could lead to an accident.**

If your trailer's total weight (trailer weight plus its cargo weight) exceeds 1,000 lbs (453 kg), the trailer is required to be equipped with its own brake system. Electric brakes or surge brakes are recommended, and must be installed properly. Check that your trailer's brakes conform with Federal, state/province and/or other applicable regulations. Your SUBARU's brake system is not designed to be tapped into the trailer's hydraulic brake system. Please ask your SUBARU

dealer and professional trailer supplier for more information about the trailer's brake system.

▼ **Trailer safety chains**

 **WARNING**

Always use safety chains between your vehicle and the trailer. Towing trailer without safety chains could create a traffic safety hazard if the trailer separates from the hitch due to coupling damage or hitch ball damage.

In case the trailer hitch connector or hitch ball should break or become disconnected, the trailer could get loose and create a traffic safety hazard.

For safety, always connect the towing vehicle and trailer with trailer safety chains. Pass the chains crossing each other under the trailer tongue to prevent the trailer from dropping onto the ground in case the trailer tongue should disconnect from the hitch ball. Allow sufficient slack in the chains taking tight turn situations into account; however, be careful not to let them drag on the ground.

For more information about the safety chain connection, refer to the instructions for your hitch and trailer.

▼ Side mirrors

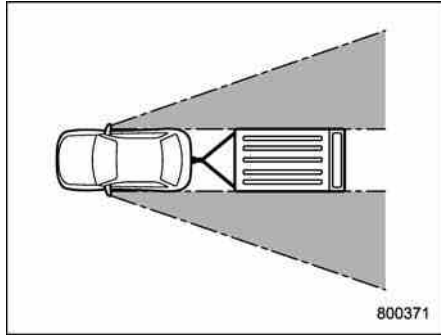

After hitching a trailer to your vehicle, check that the standard side mirrors provide a good rearward field of view without significant blind spots. If significant blind spots occur with the vehicle's standard side mirrors, use towing mirrors that conform with Federal, state/province and/or other applicable regulations.

▼ Trailer lights

 **CAUTION**

Direct splicing or other improper connection of trailer lights may damage your vehicle's electrical system and cause a malfunction of your vehicle's lighting system.

Connection of trailer lights to your vehicle's electrical system requires modifications to the vehicle's lighting circuit to increase its capacity and accommodate wiring changes. To ensure the trailer lights are connected properly, please consult your SUBARU dealer. Check for proper operation of the turn signals and the brake lights each time you hitch up.

▼ Tires

 **WARNING**

Never tow a trailer when the temporary spare tire is used. The temporary spare tire is not designed to sustain the towing load. Use of the temporary spare tire when towing can result in failure of the spare tire and/or less stability of the vehicle.

Make sure that all the tires on your vehicle are properly inflated. Refer to "Tires" 12-9 and in "GAS STATION REFERENCE" at the end of this manual.

Trailer tire condition, size, load rating and proper inflation pressure should be in accordance with the trailer manufacturer's specifications.

In the event your vehicle gets a flat tire when towing a trailer, ask a commercial

road service to repair the flat tire.

If you carry a regular size spare tire in your vehicle or trailer as a precaution against getting a flat tire, be sure that the spare tire is firmly secured.

■ Trailer towing tips

 **CAUTION**

- Never exceed 45 mph (72 km/h) when towing a trailer in hilly country on hot days.
- When towing a trailer, steering, stability, stopping distance and braking performance will be different from normal operation. For safety's sake, you should employ extra caution when towing a trailer and you should never speed. You should also keep the following tips in mind:

▼ Before starting out on a trip

- Check that the vehicle and vehicle-to-hitch mounting are in good condition. If any problems are apparent, do not tow the trailer.
- Check that the vehicle sits horizontally with the trailer attached. If the vehicle is tipped sharply up at the front and down at

the rear, check the total trailer weight, GVW, GAWs and tongue load again, then confirm that the load and its distribution are acceptable.

- Check that the tire pressures are correct.
- Check that the vehicle and trailer are connected properly. Confirm that
 - the trailer tongue is connected properly to the hitch ball.
 - the trailer lights connector is connected properly and trailer's brake lights illuminate when the vehicle's brake pedal is pressed, and that the trailer's turn signal lights flash when the vehicle's turn signal lever is operated.
 - the safety chains are connected properly.
 - all cargo in the trailer is secured safely in position.
 - the side mirrors provide a good rearward field of view without a significant blind spot.
- Sufficient time should be taken to learn the "feel" of the vehicle/trailer combination before starting out on a trip. In an area free of traffic, practice turning, stopping and backing up.

▼ Driving with a trailer

- You should allow for considerably more stopping distance when towing a trailer. Avoid sudden braking because it may result in skidding or jackknifing and loss of control.
- Avoid abrupt starts and sudden accelerations. If your vehicle has a manual transmission, always start out in first gear and release the clutch at moderate engine revolution.
- Avoid uneven steering, sharp turns and rapid lane changes.
- Slow down before turning. Make a longer than normal turning radius because the trailer wheels will be closer than the vehicle wheels to the inside of the turn. In a tight turn, the trailer could hit your vehicle.
- Crosswinds will adversely affect the handling of your vehicle and trailer, causing sway. Crosswinds can be due to weather conditions or the passing of large trucks or buses. If swaying occurs, firmly grip the steering wheel and slow down immediately but gradually.
- When passing other vehicles, considerable distance is required because of the added weight and length caused by attaching the trailer to your vehicle.

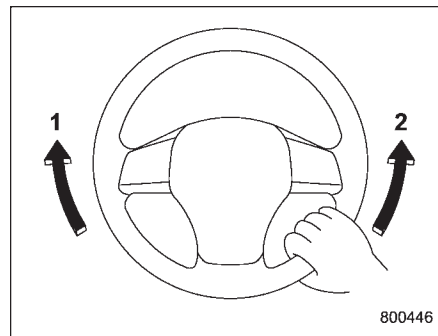

- 1) Left turn
- 2) Right turn

- Backing up with a trailer is difficult and takes practice. When backing up with a trailer, never accelerate or steer rapidly. When turning back, grip the bottom of the steering wheel with one hand and turn it to the left for a left turn, and turn it to the right for a right turn.
- If the ABS warning light illuminates while the vehicle is in motion, stop towing the trailer and have repairs performed immediately by the nearest SUBARU dealer.

▼ Driving on grades

- Before going down a steep hill, slow down and shift into lower gear (if necessary, use 1st gear) in order to utilize the

engine braking effect and prevent overheating of your vehicle's brakes. Do not make sudden downshifts.

- When driving uphill in hot weather, the air conditioner may turn off automatically to protect the engine from overheating.
- When driving uphill in hot weather, pay attention to the coolant temperature high warning light (for all models) and AT OIL TEMP warning light (for AT and CVT models) because the engine and transmission are relatively prone to overheating under these conditions. If the coolant temperature high warning light and/or the AT OIL TEMP warning light illuminates, immediately turn off the air conditioner and stop the vehicle in the nearest safe location. For further instructions and additional information, refer to the following sections.
 - “If you park your vehicle in an emergency” 9-2
 - “Engine overheating” 9-13
 - “Coolant temperature low indicator light/Coolant temperature high warning light” 3-13

– “AT OIL TEMP warning light (AT and CVT models)” 3-14

- For AT and CVT models, avoid using the accelerator pedal to stay stationary on an uphill slope instead of using the parking brake or foot brake. That may cause the transmission fluid to overheat.

▼ Parking on a grade

Always block the wheels under both vehicle and trailer when parking. Apply the parking brake. You should not park on a hill or slope. But if parking on a hill or slope cannot be avoided, you should take the following steps:

1. Apply the brakes and hold the pedal down.
2. Have someone place wheel blocks under both the vehicle and trailer wheels.
3. When the wheel blocks are in place, release the regular brakes slowly until the blocks absorb the load.
4. Apply the regular brakes and then apply the parking brake; slowly release the regular brakes.
5. Shift into 1st or reverse gear (MT models) or “P” (AT and CVT models) and shut off the engine.

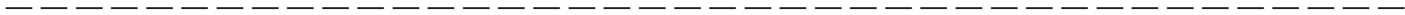
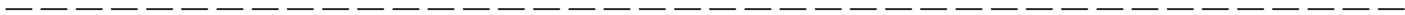
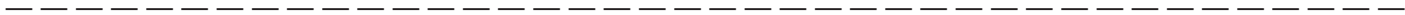
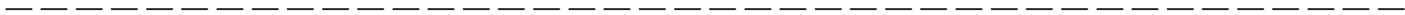
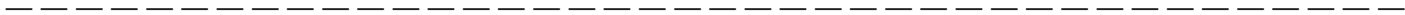

In case of emergency

If you park your vehicle in an emergency.....	9-2	If no steam is coming from the engine compartment	9-13
Temporary spare tire.....	9-2	Towing	9-13
Maintenance tools	9-3	Towing and tie-down hooks/holes	9-14
Legacy.....	9-4	Using a flat-bed truck.....	9-16
Outback	9-5	Towing with all wheels on the ground.....	9-16
Flat tires	9-6	Electronic parking brake – if the electronic parking brake cannot be released.....	9-17
Changing a flat tire.....	9-6	Trunk lid (Legacy) – if the trunk lid cannot be opened	9-19
Tire pressure monitoring system (TPMS) (if equipped).....	9-9	Rear gate (Outback) – if the rear gate cannot be unlocked.....	9-20
Jump starting	9-10	Moonroof – if moonroof cannot be closed	9-20
How to jump start.....	9-11		
Engine overheating	9-13		
If steam is coming from the engine compartment.....	9-13		

If you park your vehicle in an emergency

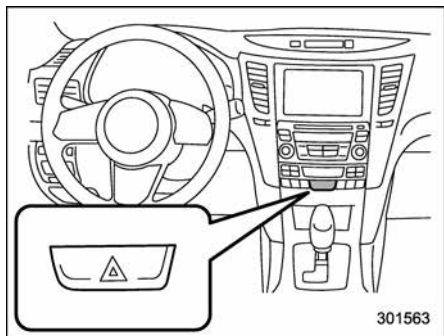

The hazard warning flasher should be used in day or night to warn other drivers when you have to park your vehicle under emergency conditions.

Avoid stopping on the road. It is best to safely pull off the road if a problem occurs.

The hazard warning flasher can be activated regardless of the ignition switch position.

Turn on the hazard warning by pressing the hazard warning flasher switch. Turn it off by pressing the switch again.

NOTE

When the hazard warning flasher is on, the turn signals do not work.

Temporary spare tire

WARNING

- Never tow a trailer when the temporary spare tire is used. The temporary spare tire is not designed to sustain the towing load. Use of the temporary spare tire when towing can result in failure of the spare tire and/or less stability of the vehicle and may lead to an accident.
- When a spare tire is mounted or a wheel rim is replaced without the original pressure sensor/transmitter being transferred, the low tire pressure warning light will illuminate steadily after blinking for approximately one minute. This indicates the tire pressure monitoring system (TPMS) is unable to monitor all four road wheels. Contact your SUBARU dealer as soon as possible for tire and sensor replacement and/or system resetting.

CAUTION

Never use any temporary spare tire other than the original. Using other sizes may result in severe mechanical damage to the drive train of your vehicle.

The temporary spare tire is smaller and lighter than a conventional tire and is designed for emergency use only. Remove the temporary spare tire and re-install the conventional tire as soon as possible because the spare tire is designed only for temporary use.

Check the inflation pressure of the temporary spare tire periodically to keep the tire ready for use. The correct pressure is **60 psi (420 kPa, 4.2 kgf/cm²)**.

When using the temporary spare tire, note the following precautions.

- Do not exceed 50 mph (80 km/h).
- Do not put a tire chain on the temporary spare tire. Because of the smaller tire size, a tire chain will not fit properly.
- Do not use two or more temporary spare tires at the same time.
- Do not drive over obstacles. This tire has a smaller diameter, so road clearance is reduced.

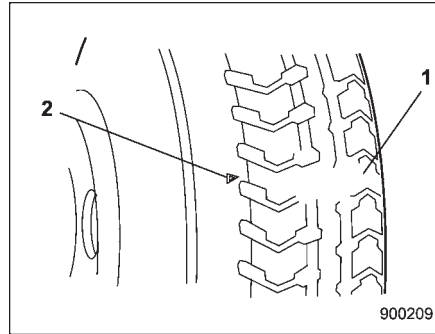

- 1) Tread wear indicator bar
- 2) Indicator location mark

- When the wear indicator appears on the tread, replace the tire.
- The temporary spare tire must be used only on a rear wheel. If a front wheel tire gets punctured, replace the wheel with a rear wheel and install the temporary spare tire in place of the removed rear wheel.

Maintenance tools

Your vehicle is equipped with the following maintenance tools.

- Jack
- Jack handle
- Screwdriver
- Towing hook (eye bolt) (if equipped)
- Wheel nut wrench
- Electronic parking brake release tool

■ Legacy

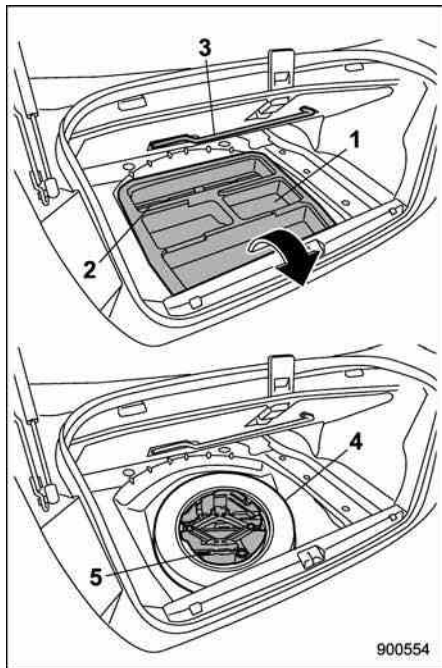

- 1) Under-floor storage compartment (Refer to "Under-floor storage compartment" ¶6-18.)
- 2) Electronic parking brake release tool
- 3) Jack handle
- 4) Spare tire

5) Tool bucket

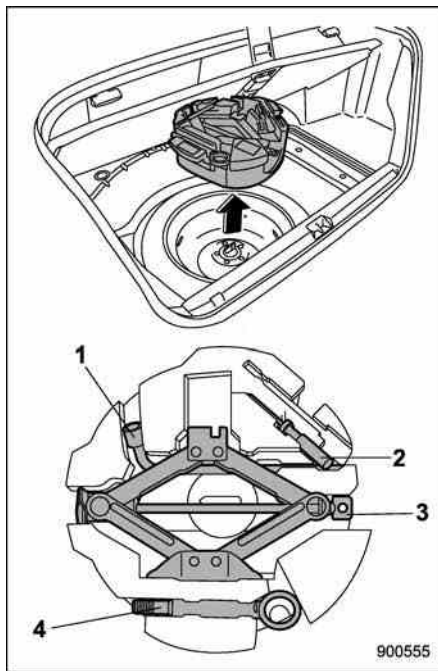

- 1) Wheel nut wrench
- 2) Screwdriver
- 3) Jack
- 4) Towing hook (eye bolt) (if equipped)

The jack handle is stored on the back of

the floor cover of the trunk. The electronic parking brake release tool is stored under the floor of the trunk. The other tools are stored in the tool bucket that is located in the recess of the spare tire wheel.

For the method to use the jack, refer to "Flat tires" ¶9-6.

For the method to use the electronic parking brake release tool, refer to "Electronic parking brake – if the electronic parking brake cannot be released" ¶9-17.

■ **Outback**

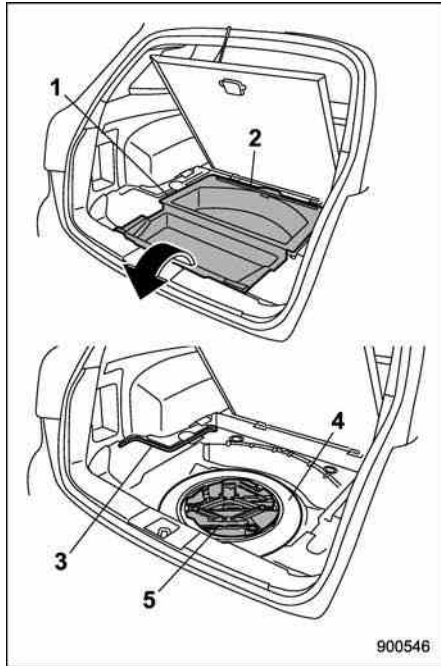

- 1) Under-floor storage compartment (Refer to “Under-floor storage compartment” ¶ 6-18.)
- 2) Electronic parking brake release tool
- 3) Jack handle
- 4) Spare tire

5) Tool bucket

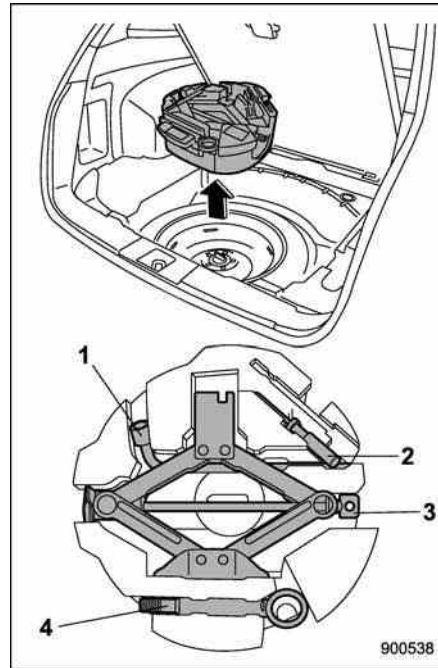

- 1) Wheel nut wrench
- 2) Screwdriver
- 3) Jack
- 4) Towing hook (eye bolt) (if equipped)

The jack handle is stored under the cargo

area. The electronic parking brake release tool is stored under the floor of the cargo area. The other tools are stored in the tool bucket that is located in the recess of the spare tire wheel.

For the method to use the jack, refer to “Flat tires” ¶ 9-6.

For the method to use the electronic parking brake release tool, refer to “Electronic parking brake – if the electronic parking brake cannot be released” ¶ 9-17.

Flat tires

If you have a flat tire while driving, never brake suddenly; keep driving straight ahead while gradually reducing speed. Then slowly pull off the road to a safe place.

■ Changing a flat tire



WARNING

- Do not jack up the vehicle on an incline or a loose road surface. The jack can come out of the jacking point or sink into the ground and this can result in a serious accident.
- Use only the jack provided with your vehicle. The jack supplied with the vehicle is designed only for changing a tire. Never get under the vehicle while supporting the vehicle with this jack.

- Always turn off the engine before raising the flat tire off the ground using the jack. Never swing or push the vehicle supported with the jack. The jack can come out of the jacking point due to a jolt and this can result in a serious accident.

1. Park on a hard, level surface, whenever possible, then stop the engine.
2. Apply the parking brake and shift the shift lever in reverse (MT models) or the select lever in the “P” (Park) position (AT and CVT models).
3. Turn on the hazard warning flasher and have everyone get out of the vehicle.

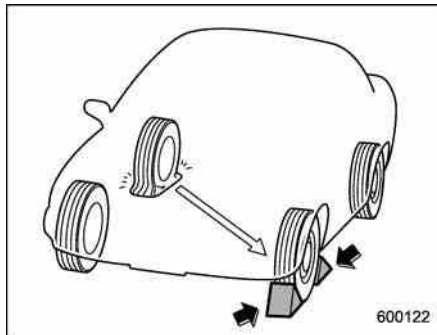

4. Put wheel blocks at the front and rear of the tire diagonally opposite the flat tire.

5. Take out the jack, jack handle and wheel nut wrench.

The tools and the spare tire are stored under the floor of the trunk (Legacy) or the cargo area (Outback). Refer to “Maintenance tools” 9-3.

NOTE

Make sure that the jack is well lubricated before using it.

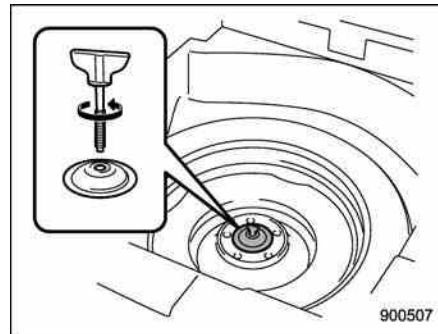

Legacy

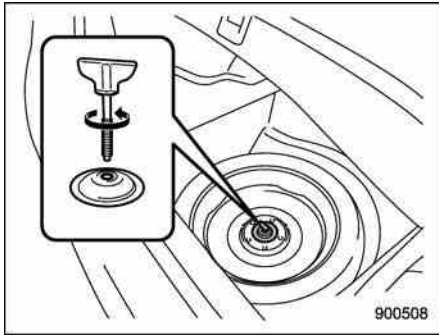

Outback

6. Take out the tool bucket and turn the attaching bolt counterclockwise, then take the spare tire out.

NOTE

If the spare tire provided in your vehicle is a temporary spare tire, carefully read "Temporary spare tire" 9-2 and strictly follow the instructions.

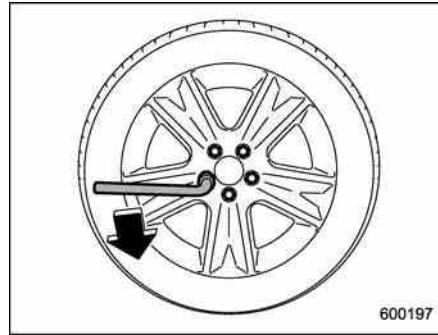

7. Loosen the wheel nuts using the wheel nut wrench but do not remove the nuts.

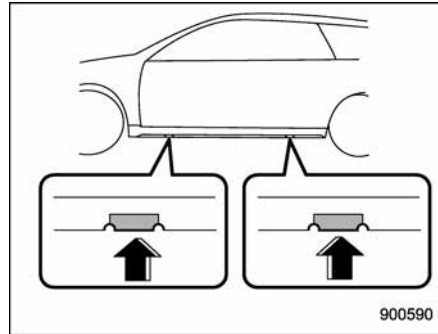

8. Place the jack under the side sill at the front or rear jack-up point closest to the flat tire.

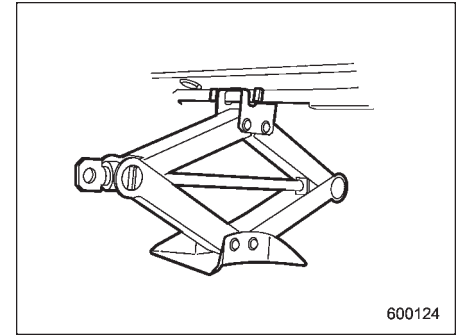

Turn the jackscrew by hand until the jack head engages firmly into the jack-up point.

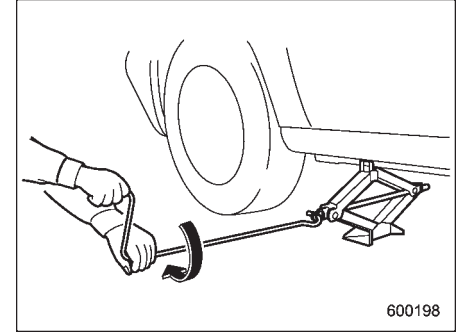

9. Insert the jack handle into the jackscrew, and turn the handle until the tire clears the ground. Do not raise the vehicle higher than necessary.

9-8 In case of emergency

10. Remove the wheel nuts and the flat tire.

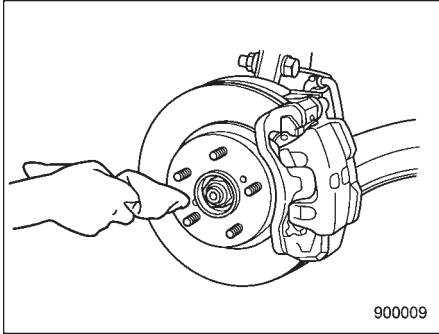

900009

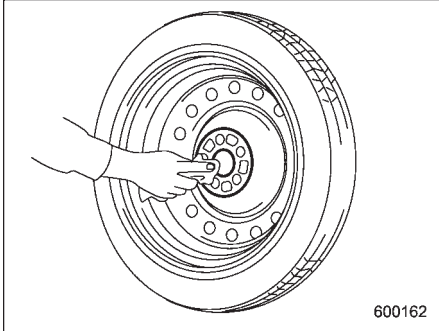

600162

11. Before putting the spare tire on, clean the mounting surface of the wheel and hub with a cloth.

12. Put on the spare tire. Replace the

wheel nuts. Tighten them by hand.

WARNING

Do not use oil or grease on the wheel studs or nuts when the spare tire is installed. This could cause the nuts to become loose and lead to an accident.

13. Turn the jack handle counterclockwise to lower the vehicle.

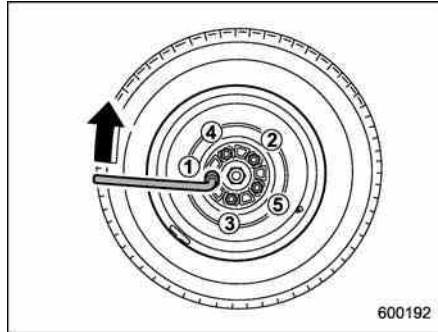

600192

14. Use the wheel nut wrench to securely tighten the wheel nuts to the specified torque, following the tightening order in the illustration.

For the wheel nut tightening torque, refer to "Tires"  12-9. Never use your foot on the wheel nut wrench or a pipe extension

on the wrench because you may exceed the specified torque. Have the wheel nut torque checked at the nearest automotive service facility.

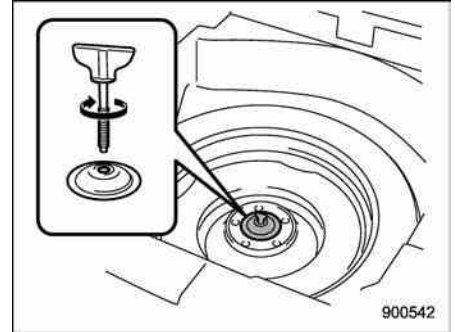

900542

Models with P205/60R16 tires

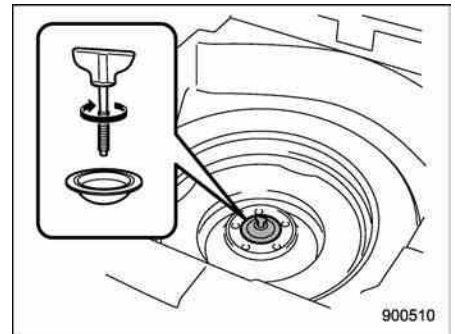

900510

Others

15. Store the flat tire in the spare tire compartment.

Put the spacer and tighten the attaching bolt firmly.

Also store the jack and jack handle in their storage locations.



WARNING

Never place a tire or tire changing tools in the passenger compartment after changing wheels. In a sudden stop or collision, loose equipment could strike occupants and cause injury. Store the tire and all tools in the proper place.

■ Tire pressure monitoring system (TPMS) (if equipped)

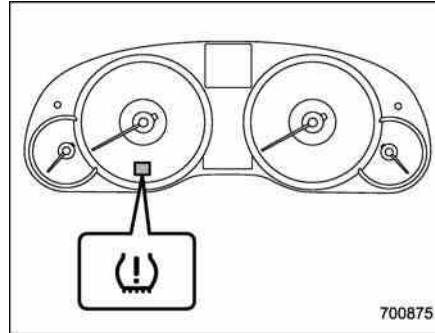

The tire pressure monitoring system provides the driver with the warning message indicated by sending a signal from a sensor that is installed in each wheel when tire pressure is severely low.

The tire pressure monitoring system will activate only when the vehicle is driven. Also, this system may not react immediately to a sudden drop in tire pressure (for example, a blow-out caused running over a sharp object).



WARNING

If the low tire pressure warning light illuminates while driving, never brake suddenly and keep driving

straight ahead while gradually reducing speed. Then slowly pull off the road to a safe place. Otherwise an accident involving serious vehicle damage and serious personal injury could occur.

Check the pressure for all four tires and adjust the pressure to the COLD tire pressure shown on the vehicle placard on the door pillar on the driver's side. If this light still illuminates while driving after adjusting the tire pressure, a tire may have significant damage and a fast leak that causes the tire to lose air rapidly. If you have a flat tire, replace it with a spare tire as soon as possible.

When a spare tire is mounted or a wheel rim is replaced without the original pressure sensor/transmitter being transferred, the low tire pressure warning light will illuminate steadily after blinking for approximately one minute. This indicates the TPMS is unable to monitor all four road wheels. Contact your SUBARU dealer as soon as possible for tire and sensor replacement and/or system resetting.

Do not inject any tire liquid or aerosol tire sealant into the tires,

as this may cause a malfunction of the tire pressure sensors.

If the light illuminates steadily after blinking for approximately one minute, promptly contact a SUBARU dealer to have the system inspected.

Jump starting



WARNING

- Battery fluid is **SULFURIC ACID**. Do not let it come in contact with the eyes, skin, clothing or the vehicle.

If battery fluid gets on you, thoroughly flush the exposed area with water immediately. Get medical help if the fluid has entered your eyes.

If battery fluid is accidentally swallowed, immediately drink a large amount of milk or water, and obtain immediate medical help.

Keep everyone including children away from the battery.

- The gas generated by a battery explodes if a flame or spark is brought near it. Do not smoke or light a match while jump starting.
- Never attempt jump starting if the discharged battery is frozen. It could cause the battery to burst or explode.
- Whenever working on or around a battery, always wear suitable

eye protectors, and remove metal objects such as rings, bands or other metal jewelry.

- Be sure the jumper cables and clamps on them do not have loose or missing insulation.
- Do not jump start unless cables in suitable condition are available.
- A running engine can be dangerous. Keep your fingers, hands, clothing, hair and tools away from the cooling fan, belts and any other moving engine parts. Removing rings, watches and ties is advisable.
- Jump starting is dangerous if it is done incorrectly. If you are unsure about the proper procedure for jump starting, consult a competent mechanic.

When your vehicle does not start due to a run down (discharged) battery, the vehicle may be jump started by connecting your battery to another battery (called the booster battery) with jumper cables.

■ **How to jump start**

1. Make sure the booster battery is 12 volts and the negative terminal is grounded.
2. If the booster battery is in another vehicle, do not let the two vehicles touch.
3. Turn off all unnecessary lights and accessories.
4. Connect the jumper cables exactly in the sequence illustrated.

9-12 In case of emergency

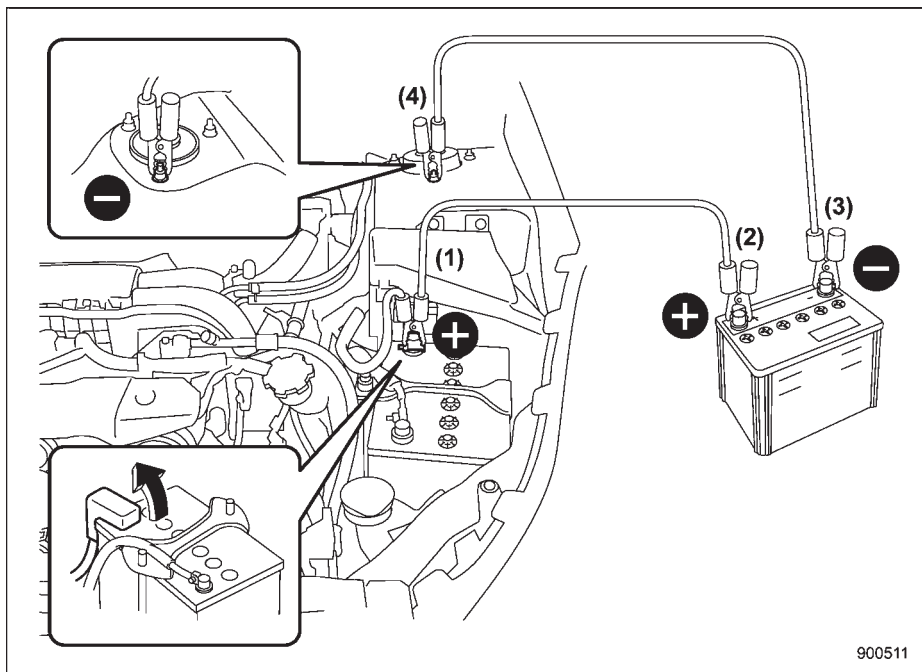

- 1) Connect one jumper cable to the positive (+) terminal on the discharged battery.
- 2) Connect the other end of the jumper cable to the positive (+) terminal of the booster battery.
- 3) Connect one end of the other cable to the negative (-) terminal of the booster battery.
- 4) Connect the other end of the cable to the strut mounting nut.

Make sure that the cables are not near any moving parts and that the cable clamps are not in contact with any other metal.

5. Start the engine of the vehicle with the booster battery and run it at moderate speed. Then start the engine of the vehicle that has the discharged battery.
6. When finished, carefully disconnect the cables in exactly the reverse order.

Engine overheating

WARNING

Never attempt to remove the radiator cap until the engine has been shut off and has fully cooled down. When the engine is hot, the coolant is under pressure. Removing the cap while the engine is still hot could release a spray of boiling hot coolant, which could burn you very seriously.

If the engine overheats, pull off the road safely and stop the vehicle in a safe place.

■ If steam is coming from the engine compartment

Turn off the engine and get everyone away from the vehicle until it cools down.

■ If no steam is coming from the engine compartment

NOTE

For details about how to check the coolant level or how to add coolant, refer to “Engine coolant”  11-17.

1. Keep the engine running at idling speed.

2. Open the hood to ventilate the engine compartment. Refer to “Engine hood”  11-7.

Confirm that the cooling fan is turning. If the fan is not turning, immediately turn off the engine and contact your authorized dealer for repair.

3. After the engine coolant temperature has dropped, turn off the engine.

If the coolant temperature high warning light illuminates, turn off the engine. Refer to “Coolant temperature low indicator light/ Coolant temperature high warning light”  3-13.

4. After the engine has fully cooled down, check the coolant level in the reserve tank.

If the coolant level is below the “LOW” mark, add coolant up to the “FULL” mark.

5. If there is no coolant in the reserve tank, add coolant to the reserve tank. Then remove the radiator cap and fill the radiator with coolant.

If you remove the radiator cap from a hot radiator, first wrap a thick cloth around the radiator cap, then turn the cap counter-clockwise slowly without pressing down until it stops. Release the pressure from the radiator. After the pressure has been fully released, remove the cap by pressing down and turning it.

Towing

WARNING

Never tow AWD vehicles (including AT, MT and CVT) with the front wheels raised off the ground while the rear wheels are on the ground, or with the rear wheels raised off the ground while the front wheels are on the ground. This will cause the vehicle to spin away due to the operation or deterioration of the center differential.

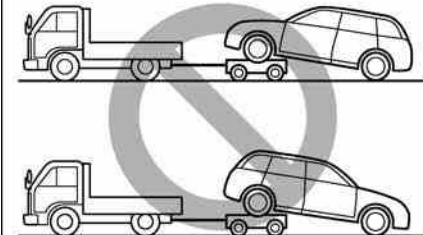

900487

If towing is necessary, it is best done by your SUBARU dealer or a commercial towing service. Observe the following procedures for safety.

■ Towing and tie-down hooks/holes

The towing hooks should be used only in an emergency (e.g., to free a stuck vehicle from mud, sand or snow).

▲ CAUTION

- Use only the specified towing hooks and tie-down hooks/holes. Never use suspension parts or other parts of the body for towing or tie-down purposes.
- Never use the tie-down hole closest to the muffler under the vehicle for towing purposes.
- To prevent deformation to the bumper and the towing hook, do not apply excessive lateral load to the towing hooks.

Front towing hook:

1. Take out the towing hook and screwdriver from the on board tool bucket. Take out the jack handle from the trunk (Legacy) or cargo area (Outback).

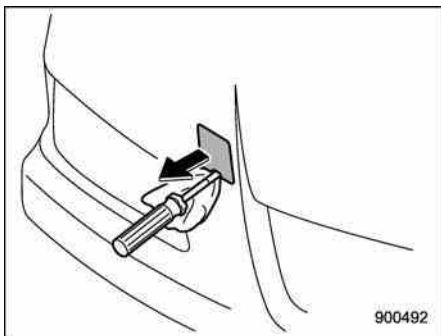

2. Pry off the cover on the front bumper using a screwdriver, and you will find a threaded hole for attaching the towing hook.

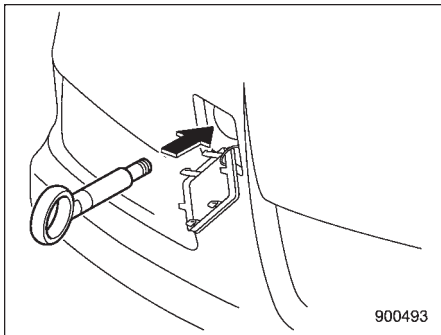

3. Screw the towing hook into the threaded hole until the threads can no

longer be seen.

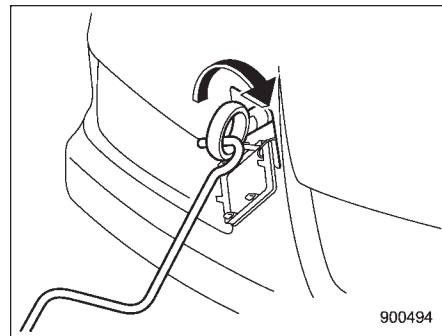

4. Tighten the towing hook securely using the jack handle.

After towing, remove the towing hook from the vehicle and stow it in the tool bucket. Fit the towing hook cover on the bumper.

▲ WARNING

- Do not use the towing hook except when towing your vehicle.
- Be sure to remove the towing hook after towing. Leaving the towing hook mounted on the vehicle could interfere with proper operation of the SRS airbag system in a frontal collision.

Rear towing hook:

1. Take the towing hook out of the tool bucket and take the screwdriver out of the tool bucket. Take the jack handle out of the trunk (Legacy) or cargo area (Outback).

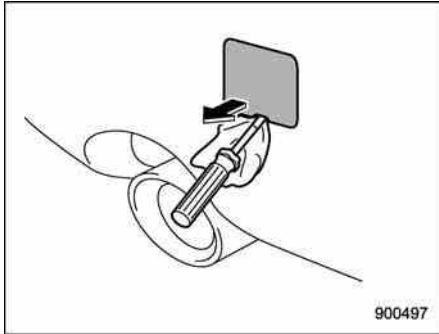

2. Pry off the cover on the rear bumper using a screwdriver, and you will find a threaded hole for attaching the towing hook.

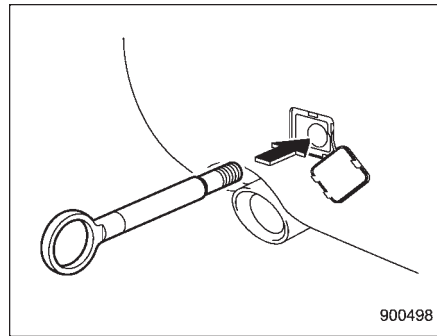

3. Screw the towing hook into the threaded hole until its thread can no longer be seen.

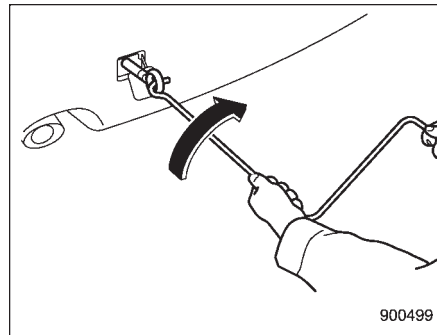

4. Tighten the towing hook securely using the jack handle.

After towing, remove the towing hook from the vehicle and stow it in the tool bucket. Fit the towing hook cover on the bumper.

⚠ WARNING

Do not use the towing hook except when towing your vehicle.

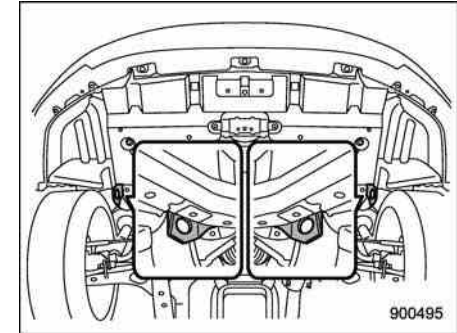
Front tie-down hooks:

The front tie-down hooks are located between each of the front tires and the front bumper.

Rear tie-down holes:

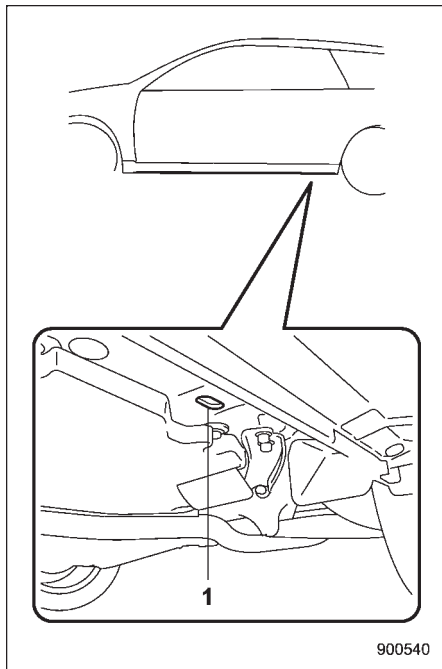

1) Rear tie-down hole

The rear tie-down holes are located near each of the jack-up reinforcements.

⚠ WARNING

Use the rear tie-down holes only for downward anchoring. If they are used to anchor the vehicle in any other direction, cables may slip out of the holes, possibly causing a dangerous situation.

■ **Using a flat-bed truck**

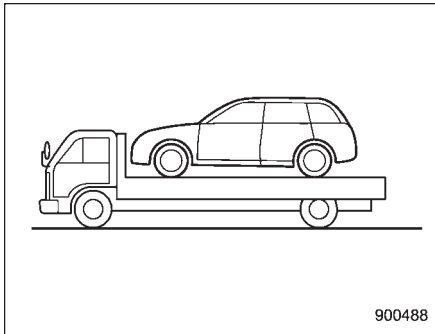

This is the best way to transport your vehicle. Use the following procedures to ensure safe transportation.

1. Shift the select lever into the “P” position for AT and CVT models or the shift lever into “1st” for MT models.
2. Apply the parking brake.
3. Secure the vehicle onto the carrier

properly with safety chains. Each safety chain should be equally tightened and care must be taken not to pull the chains so tightly that the suspension bottoms out.

■ **Towing with all wheels on the ground**

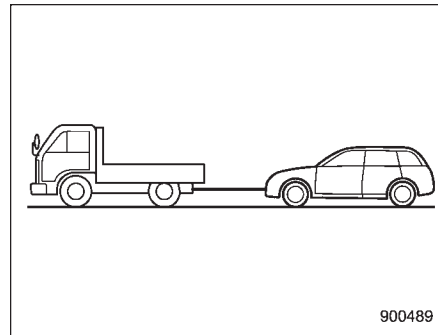

⚠ WARNING

- Never turn the ignition switch to the “LOCK” position while the vehicle is being towed because the steering wheel and the direction of the wheels will be locked.
- Remember that the brake booster and power steering do not function when the engine is not running. Because the engine is

turned off, it will take greater effort to operate the brake pedal and steering wheel.



CAUTION

- If transmission failure occurs, transport your vehicle on a flat-bed truck.
- Do not run the engine while being towed using this method. Transmission damage could result if the vehicle is towed with the engine running.
- For AT and CVT models, the traveling speed must be limited to less than 20 mph (30 km/h) and the traveling distance to less than 31 miles (50 km). For greater speeds and distances, transport your vehicle on a flat-bed truck.

1. Release the parking brake and put the transmission in neutral.
2. The ignition switch should be in the "Acc" position while the vehicle is being towed.
3. Take up slack in the towline slowly to prevent damage to the vehicle.

Electronic parking brake – if the electronic parking brake cannot be released



WARNING

- When the electronic parking brake cannot be released, the electronic parking brake system may malfunction. Driving in such conditions may cause an unexpected accident. Contact your SUBARU dealer for inspection as soon as possible.
- You can release the electronic parking brake by using the electronic parking brake release tool in case of an emergency. However, after releasing the electronic parking brake by using the electronic parking brake release tool, contact your SUBARU dealer for inspection as soon as possible.
- Release the electronic parking brake by using the electronic parking brake release tool on a level road. Otherwise, the vehicle may move, which could cause an accident.

- When releasing the electronic parking brake by using the electronic parking brake release tool, always perform the following items.
 - Shift the shift lever in the "1" or "R" position (MT models).
 - Shift the select lever in the "P" position (AT and CVT models).
 - Use tire stops under the tires.
- When releasing the electronic parking brake by using the electronic parking brake release tool, make sure that the ignition switch is in the "LOCK" position. Otherwise, the electronic parking brake system may operate and the electronic parking brake release tool may rotate and unexpected accident may occur.



CAUTION

- Under certain weather conditions (rain, snow, sandstorm, etc.), do not release the electronic parking brake by using the electronic parking brake release tool. If water or dust enters the device, the device may malfunction.

- If the cap cannot be removed, contact your SUBARU dealer for inspection.
- After releasing the electronic parking brake by using the electronic parking brake release tool, make sure that the cap is reinstalled to the parking brake release device. If the cap is not reinstalled, water or dust enters the device and the device may malfunction.

NOTE

It may be difficult to release the electronic parking brake by using the electronic parking brake release tool. Have your SUBARU dealer release the electronic parking brake if necessary.

In the event that you cannot release the electronic parking brake by pulling the electronic parking brake switch or by depressing the accelerator pedal, you can release the electronic parking brake manually by using the electronic parking brake release tool.

1. Shift the shift lever in the “1” or “R” position (MT models) or the select lever in the “P” position (AT and CVT models).
2. Turn the ignition switch to the “LOCK” position.

3. Make sure that the brake system warning light and the indicator light on the parking brake switch have turned off.
4. Use tire stops under the tires to prevent the vehicle from moving.
5. Take out the electronic parking brake release tool. Refer to “Maintenance tools” 9-3.

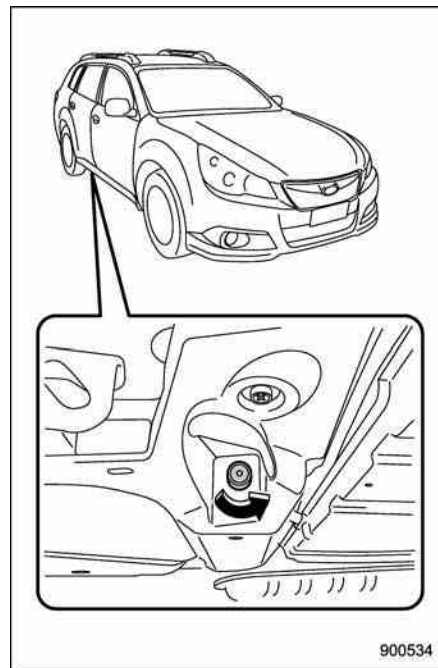

6. Insert the electronic parking brake release tool into the cap of the parking brake release device.
7. Remove the cap of the parking brake release device by turning the electronic parking brake release tool counterclock-

wise.

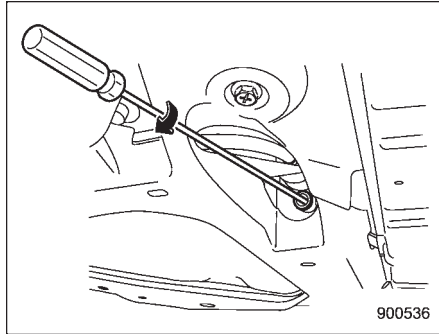

8. Break the white film and insert the electronic parking brake release tool into the parking brake release device.

9. Turn the electronic parking brake release tool clockwise approximately 200 to 250 rotations.

10. To confirm that the electronic parking brake is released, shift the shift lever or the select lever to the "N" position, slightly move the tire stops and have someone push the vehicle slightly while you remain in the driver's seat. If the vehicle moves, the electronic parking brake has been released.

11. Readjust the tire stops.

12. Reinstall the cap to the parking brake release device.

CAUTION

- Do not turn the electronic parking brake release tool counterclockwise or turn it around more than 300 times. Doing so may result in a malfunction of the electronic parking brake.
- Do not use electric power tools to turn the electronic parking brake release tool. Doing so may result in a malfunction of the electronic parking brake.

Trunk lid (Legacy) – if the trunk lid cannot be opened

The trunk lid can also be opened using the key.

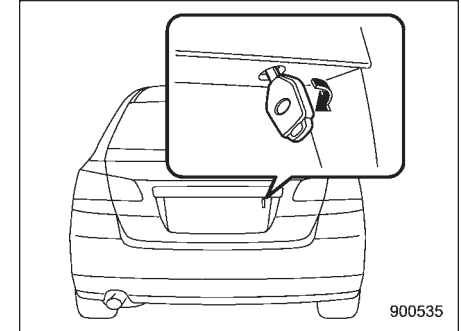

To open the trunk lid, insert the key into the key cylinder and turn it clockwise.

Rear gate (Outback) – if the rear gate cannot be unlocked

In the event that you cannot unlock the rear gate by operating the power door locking switches or the remote keyless entry system, you can unlock it from inside the cargo area.

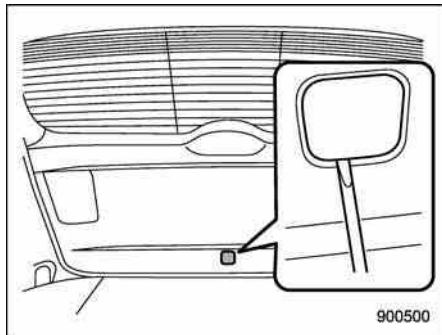

1. Remove the access cover at the bottom-center of the rear gate trim using flat-head screwdriver.
2. Locate the rear gate lock release lever behind the rear gate trim panel.



CAUTION

Never operate the rear gate lock release lever with your fingers because doing so may cause an injury.

Always use a flat-head screwdriver or a similar tool.



3. To unlock the rear gate, turn the lever to the right position using a flat-head screwdriver or a similar tool.
4. Open the rear gate from outside by raising the rear gate handle.

Moonroof – if moonroof cannot be closed

If the moonroof cannot be closed with the moonroof switch, you can close the moonroof manually.

1. Take out the screwdriver from the tool bucket.
2. Open the overhead console. Refer to "Overhead console" 6-8.

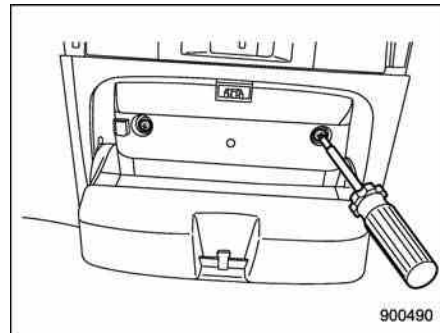

3. Remove the two screws that retain the moonroof switch body. Then, remove the moonroof switch.

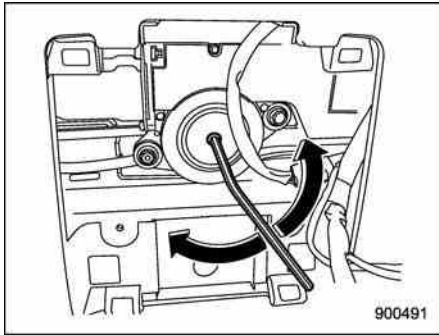

4. Insert the hex-head wrench in the end of the motor shaft.

To lower the moonroof, turn the wrench clockwise.

To close the moonroof, turn the wrench counterclockwise.

Have your vehicle checked and repaired by an authorized SUBARU dealer.

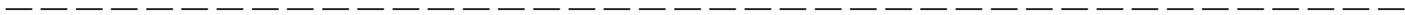
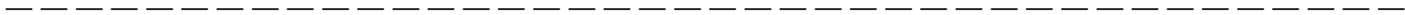
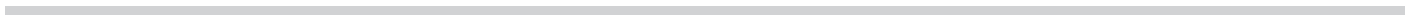

Exterior care	10-2	Cleaning the interior	10-5
Washing	10-2	Seat fabric	10-5
Waxing and polishing	10-3	Leather seat materials	10-5
Cleaning aluminum wheels	10-3	Synthetic leather upholstery	10-5
Corrosion protection	10-4	Climate control panel, audio panel, instrument panel, console panel, switches, combination meter, and other plastic surface	10-5
Most common causes of corrosion	10-4	Monitor (if equipped)	10-6
To help prevent corrosion	10-4		

Exterior care

■ Washing

CAUTION

- When washing the vehicle, the brakes may get wet. As a result, the brake stopping distance will be longer. To dry the brakes, drive the vehicle at a safe speed while lightly pressing the brake pedal to heat up the brakes.
- Do not wash the engine compartment and areas adjacent to it. If water enters the engine air intake, electrical parts or the power steering fluid reservoir, it will cause engine trouble or a malfunction of the power steering.
- Do not use any organic solvents when washing the surface of the bulb assembly cover. However, if a detergent with organic solvents is used to wash the cover surface, completely rinse off the detergent with water. Otherwise, the cover surface may be damaged.
- **Outback:** Since your vehicle is equipped with a rear wiper, automatic car-wash brushes could

become tangled around it, damaging the wiper arm and other components. Ask the automatic car-wash operator not to let the brushes touch the wiper arm or to fix the wiper arm on the rear window glass with adhesive tape before operating the machine.

NOTE

When having your vehicle washed in an automatic car wash, make sure beforehand that the car wash is of suitable type.

The best way to preserve your vehicle's beauty is frequent washing. Wash the vehicle at least once a month to avoid contamination by road grime.

Wash dirt off with a wet sponge and plenty of lukewarm or cold water. Do not wash the vehicle with hot water and in direct sunlight.

Salt, chemicals, insects, tar, soot, tree sap, and bird droppings should be washed off by using a light detergent, as required. If you use a light detergent, make certain that it is a neutral detergent. Do not use strong soap or chemical detergents. All cleaning agents should be promptly flushed from the surface and not allowed

to dry there. Rinse the vehicle thoroughly with plenty of lukewarm water. Wipe the remaining water off with a chamois or soft cloth.

▼ Washing the underbody

Chemicals, salts and gravel used for deicing road surfaces are extremely corrosive, accelerating the corrosion of underbody components, such as the exhaust system, fuel and brake lines, brake cables, floor pan and fenders, and suspension.

Thoroughly flush the underbody and inside of the fenders with lukewarm or cold water at frequent intervals to reduce the harmful effects of such agents.

Mud and sand adhering to the underbody components may accelerate their corrosion.

After driving off-road or on muddy or sandy roads, wash the mud and sand off the underbody.

Carefully flush the suspension and axle parts, as they are particularly prone to mud and sand buildup. Do not use a sharp-edged tool to remove caked mud.

CAUTION

- **Be careful not to damage brake hoses, sensor harnesses, and**

other parts when washing suspension components.

- **Be careful not to flush the engine bottom for a long time. It may cause damage of some electrical parts.**

▼ Using a warm water washer

- Keep a good distance of 12 in (30 cm) or more between the washer nozzle and the vehicle.
- Do not wash the same area continuously.
- If a stain will not come out easily, wash by hand. Some warm water washers are of the high temperature, high pressure type, and they can damage or deform the resin parts such as mouldings, or cause water to leak into the vehicle.

■ Waxing and polishing

Always wash and dry the vehicle before waxing and polishing.

Use a good quality polish and wax and apply them according to the manufacturer's instructions. Wax or polish when the painted surface is cool.

Be sure to polish and wax the chrome trim, as well as the painted surfaces. Loss of wax on a painted surface leads to loss of the original luster and also quickens the

deterioration of the surface. It is recommended that a coat of wax be applied at least once a month, or whenever the surface no longer repels water.

If the appearance of the paint has diminished to the point where the luster or tone cannot be restored, lightly polish the surface with a fine-grained compound. Never polish just the affected area, but include the surrounding area as well. Always polish in only one direction. A No. 2000 grain compound is recommended. Never use a coarse-grained compound. Coarser grained compounds have a smaller grain-size number and could damage the paint. After polishing with a compound, coat with wax to restore the original luster. Frequent polishing with a compound or an incorrect polishing technique will result in removing the paint layer and exposing the undercoat. When in doubt, it is always best to contact your SUBARU dealer or an auto paint specialist.



CAUTION

Do not use any agents with organic solvents on the surface of the bulb assembly cover. However, if a polish or wax with organic solvents is applied to the cover surface, com-

pletely wipe off the polish or wax. Otherwise, the cover surface may be damaged.

NOTE

Be careful not to block the windshield washer nozzles with wax when waxing the vehicle.

■ Cleaning aluminum wheels

- Promptly wipe the aluminum wheels clean of any kind of grime or agent. If dirt is left on too long, it may be difficult to clean off.
- Do not use soap containing grit to clean the wheels. Be sure to use a neutral cleaning agent, and later rinse thoroughly with water. Do not clean the wheels with a stiff brush or expose them to a high-speed washing device.
- Clean the vehicle (including the aluminum wheels) with water as soon as possible when it has been splashed with sea water, exposed to sea breezes, or driven on roads treated with salt or other agents.

Corrosion protection

Your SUBARU has been designed and built to resist corrosion. Special materials and protective finishes have been used on most parts of the vehicle to help maintain fine appearance, strength, and reliable operation.

■ Most common causes of corrosion

The most common causes of corrosion are:

1. The accumulation of moisture retaining dirt and debris in body panel sections, cavities, and other areas.
2. Damage to paint and other protective coatings caused by gravel and stone chips or minor accidents.

Corrosion is accelerated on the vehicle when:

1. It is exposed to road salt or dust control chemicals, or used in coastal areas where there is more salt in the air, or in areas where there is considerable industrial pollution.
2. It is driven in areas of high humidity, especially when temperatures range just above freezing.
3. Dampness in certain parts of the vehicle remains for a long time, even

though other parts of the vehicle may be dry.

4. High temperatures will cause corrosion to parts of the vehicle which cannot dry quickly due to lack of proper ventilation.

■ To help prevent corrosion

Wash the vehicle regularly to prevent corrosion of the body and suspension components. Also, wash the vehicle promptly after driving on any of the following surfaces.

- roads that have been salted to prevent them from freezing in winter
- mud, sand, or gravel
- coastal roads

After the winter has ended, it is recommended that the underbody be given a very thorough washing.

Before the beginning of winter, check the condition of underbody components, such as the exhaust system, fuel and brake lines, brake cables, suspension, steering system, floor pan, and fenders. If any of them are found to be rusted, they should be given an appropriate rust prevention treatment or should be replaced. Contact your SUBARU dealer to perform this kind of maintenance and treatment if you need

assistance.

Repair chips and scratches in the paint as soon as you find them.

Check the interior of the vehicle for water and dirt accumulation under the floor mats because that could cause corrosion. Occasionally check under the mats to make sure the area is dry.

Keep your garage dry. Do not park your vehicle in a damp, poorly ventilated garage. In such a garage, corrosion can be caused by dampness. If you wash the vehicle in the garage or put the vehicle into the garage when wet or covered with snow, that can cause dampness.

If your vehicle is operated in cold weather and/or in areas where road salts and other corrosive materials are used, the door hinges and locks, trunk lid lock, and hood latch should be inspected and lubricated periodically.

Cleaning the interior

Use a soft, damp cloth to clean the climate control panel, audio equipment, instrument panel, center console, combination meter panel, and switches. (Do not use organic solvents.)

■ **Seat fabric**

Remove loose dirt, dust or debris with a vacuum cleaner. If the dirt is caked on the fabric or hard to remove with a vacuum cleaner, use a soft brush then vacuum it. Wipe the fabric surface with a tightly wrung cloth and dry the seat fabric thoroughly. If the fabric is still dirty, wipe using a solution of mild soap and luke-warm water then dry thoroughly.

If the stain does not come out, try a commercially available fabric cleaner. Use the cleaner on a hidden place and make sure it does not affect the fabric adversely. Use the cleaner according to its instructions.

NOTE

When cleaning the seat, do not use benzine, paint thinner, or any similar materials.

■ **Leather seat materials**

The leather used by SUBARU is a high quality natural product which will retain its distinctive appearance and feel for many years with proper care.

Allowing dust or road dirt to build up on the surface can cause the material to become brittle and to wear prematurely. Regular cleaning with a soft, moist, natural fiber cloth should be performed monthly, taking care not to soak the leather or allow water to penetrate the stitched seams.

A mild detergent suitable for cleaning woolen fabrics may be used to remove difficult dirt spots, rubbing with a soft, dry cloth afterwards to restore the luster. If your SUBARU is to be parked for a long time in bright sunlight, it is recommended that the seats and headrests be covered, or the windows shaded, to prevent fading or shrinkage.

Minor surface blemishes or bald patches may be treated with a commercial leather spray lacquer. You will discover that each leather seat section will develop soft folds or wrinkles, which is characteristic of genuine leather.

■ **Synthetic leather upholstery**

The synthetic leather material used on the SUBARU may be cleaned using mild soap

or detergent and water, after first vacuuming or brushing away loose dirt. Allow the soap to soak in for a few minutes and wipe off with a clean, damp cloth. Commercial foam-type cleaners suitable for synthetic leather materials may be used when necessary.

NOTE

Strong cleaning agents such as solvents, paint thinners, window cleaner or gasoline must never be used on leather or synthetic interior materials.

■ **Climate control panel, audio panel, instrument panel, console panel, switches, combination meter, and other plastic surface**

Use a soft, damp cloth to clean the climate control panel, audio equipment, instrument panel, center console, combination meter panel, and switches.

NOTE

Do not use organic solvents such as paint thinners or gasoline, or strong cleaning agents that contain those solvents.

■ **Monitor (if equipped)**

To clean the audio/navigation monitor, wipe it with a silicone cloth or with a soft cloth. If the monitor is extremely dirty, clean it with a soft cloth moistened with neutral detergent then carefully wipe off any remaining detergent.

NOTE

- **Do not spray neutral detergent directly onto the monitor. Doing so could damage the monitor's components.**
- **Do not wipe the monitor with a hard cloth. Doing so could scratch the monitor.**
- **Do not use cleaning fluid that contains thinner, gasoline, or any other volatile substance. Such cleaning fluid could erase the lettering on the switches at the bottom of the monitor.**

Maintenance schedule	11-3	Manual transmission oil	11-21
Maintenance precautions.....	11-3	Recommended grade and viscosity	11-21
Before checking or servicing in the engine compartment.....	11-4	Automatic transmission fluid.....	11-21
When checking or servicing in the engine compartment (2.5 L non-turbo models)	11-4	Checking the fluid level.....	11-21
When checking or servicing in the engine compartment while the engine is running.....	11-5	Recommended fluid.....	11-22
Maintenance tips	11-5	Continuously variable transmission fluid	11-23
Removing and reinstalling clips	11-5	Front differential gear oil (AT and CVT models).....	11-23
Removing air intake duct.....	11-7	Checking the oil level	11-23
Pulling off the fender lining	11-7	Recommended grade and viscosity	11-24
Engine hood	11-7	Rear differential gear oil.....	11-24
Engine compartment overview.....	11-9	Recommended grade and viscosity	11-24
2.5 L non-turbo models	11-9	Power steering fluid	11-24
2.5 L turbo models	11-10	Checking the fluid level.....	11-24
3.6 L models	11-11	Recommended fluid.....	11-25
Engine oil.....	11-12	Brake fluid.....	11-25
Checking the oil level.....	11-12	Checking the fluid level.....	11-25
Changing the oil and oil filter.....	11-14	Recommended brake fluid	11-26
Recommended grade and viscosity	11-16	Clutch fluid (MT models).....	11-26
Synthetic oil.....	11-16	Checking the fluid level.....	11-26
Cooling system	11-16	Recommended clutch fluid.....	11-27
Cooling fan, hose and connections	11-17	Brake booster	11-27
Engine coolant.....	11-17	Brake pedal	11-28
Air cleaner element.....	11-18	Checking the brake pedal free play	11-28
Replacing the air cleaner element	11-18	Checking the brake pedal reserve distance.....	11-28
Spark plugs	11-20	Clutch pedal (MT models)	11-29
Recommended spark plugs	11-20	Checking the clutch function.....	11-29
Drive belts	11-21	Checking the clutch pedal free play.....	11-29
		Replacement of brake pad and lining	11-29
		Breaking-in of new brake pads and linings	11-30

Tires and wheels	11-30	Battery	11-43
Types of tires	11-30	Fuses	11-44
Tire pressure monitoring system (TPMS) (if equipped).....	11-30	Installation of accessories	11-45
Tire inspection	11-32	Replacing bulbs	11-45
Tire pressures and wear	11-32	Headlight.....	11-45
Wheel balance.....	11-34	Front turn signal light	11-48
Wear indicators	11-35	Front position light	11-48
Tire rotation direction mark	11-35	Front fog light (if equipped).....	11-48
Tire rotation	11-35	Rear combination lights	11-49
Tire replacement	11-36	Tail/Back-up light (Outback)	11-51
Wheel replacement.....	11-37	License plate light	11-52
Aluminum wheels	11-37	Dome light.....	11-53
Windshield washer fluid	11-37	Map light	11-54
Replacement of wiper blades	11-39	Vanity mirror light.....	11-54
Windshield wiper blade assembly	11-39	Door step light.....	11-55
Windshield wiper blade rubber	11-40	Cargo area light (Outback)	11-55
Rear window wiper blade assembly (Outback).....	11-41	Trunk light (Legacy).....	11-55
Rear window wiper blade rubber (Outback).....	11-41	Other bulbs	11-55

Maintenance schedule

The scheduled maintenance items required to be serviced at regular intervals are shown in the “Warranty and Maintenance Booklet”.

For details about your maintenance schedule, read the separate “Warranty and Maintenance Booklet”.

Maintenance precautions

When maintenance and service are required, it is recommended that all work be done by an authorized SUBARU dealer.

If you perform maintenance and service by yourself, you should familiarize yourself with the information provided in this section on general maintenance and service for your SUBARU.

Incorrect or incomplete service could cause improper or unsafe vehicle operation. Any problems caused by improper maintenance and service performed by you are not eligible for warranty coverage.

WARNING

- **Testing of an All-Wheel Drive vehicle must NEVER be performed on a single two-wheel dynamometer or similar apparatus. Attempting to do so will result in transmission damage and in uncontrolled vehicle movement and may cause an accident or injuries to persons nearby.**
- **Always select a safe area when performing maintenance on your vehicle.**

- **Always be very careful to avoid injury when working on the vehicle. Remember that some of the materials in the vehicle may be hazardous if improperly used or handled, for example, battery acid.**
- **Your vehicle should only be serviced by persons fully competent to do so. Serious personal injury may result to persons not experienced in servicing vehicles.**
- **Always use the proper tools and make certain that they are well maintained.**
- **Never get under the vehicle supported only by a jack. Always use safety stands to support the vehicle.**
- **Never keep the engine running in a poorly ventilated area, such as a garage or other closed areas.**
- **Do not smoke or allow open flames around the fuel or battery. This will cause a fire.**
- **Because the fuel system is under pressure, replacement of the fuel filter should be performed only by your SUBARU dealer.**
- **Wear adequate eye protection to**

guard against getting oil or fluids in your eyes. If something does get in your eyes, thoroughly wash them out with clean water.

- Do not tamper with the wiring of the SRS airbag system or seatbelt pretensioner system, or attempt to take its connectors apart, as that may activate the system or it can render it inoperative. **NEVER** use a circuit tester for these wiring. If your SRS airbag or seatbelt pretensioner needs service, consult your nearest SUBARU dealer.

■ Before checking or servicing in the engine compartment

WARNING

- Always stop the engine and apply the parking brake to prevent the vehicle from moving.
- Always let the engine cool down. Engine parts become very hot when the engine is running and remain hot for some time after the engine is stopped.
- Do not spill engine oil, engine coolant, brake fluid or any other fluid on hot engine components. This may cause a fire.
- Always remove the key from the ignition switch. When the ignition switch is in the "ON" position, the cooling fan may operate suddenly even when the engine is stopped.
- Before performing any servicing on a vehicle equipped with a remote engine start system temporarily place that system in the service mode to prevent it from unexpectedly starting the engine.

■ When checking or servicing in the engine compartment (2.5 L non-turbo models)

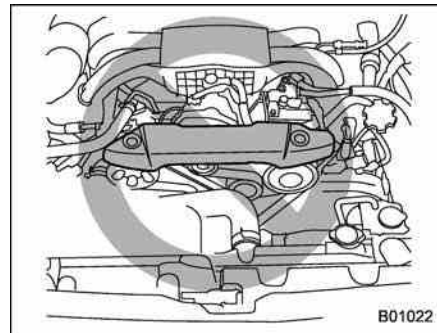

CAUTION

Do not contact the belt cover while checking the components in the engine compartment. Doing so may cause your hand to slip off the belt cover and result in an unexpected injury.

■ **When checking or servicing in the engine compartment while the engine is running**

WARNING

A running engine can be dangerous. Keep your fingers, hands, clothing, hair and tools away from the cooling fan, belts and any other moving engine parts. Removing rings, watches and ties is advisable.

Maintenance tips

Some clips and fender linings must be removed before replacing the air cleaner elements or specific bulbs.

■ **Removing and reinstalling clips**

▼ **Removing clips**

There are several types of clips used for your vehicle.

▽ **Type A clips**

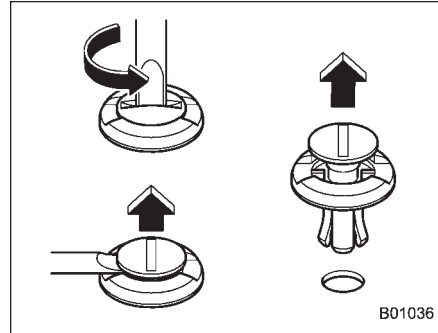

1. Turn the clips counterclockwise using a flat-head screwdriver until the center portion of the clip is raised.
2. Remove the clips with a flat-head screwdriver using leverage.

▽ **Type B clips**

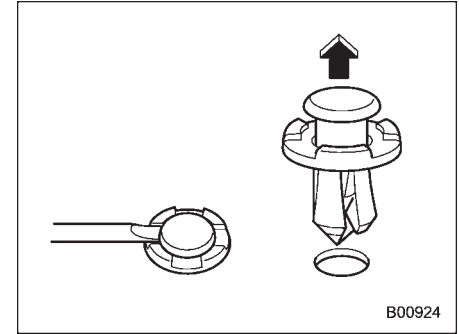

1. Pull out the center portion of the clip using a flat-head screwdriver as shown in the illustration.
2. Pull the protruded center portion to remove the entire body of the clip.

▽ Type C clips

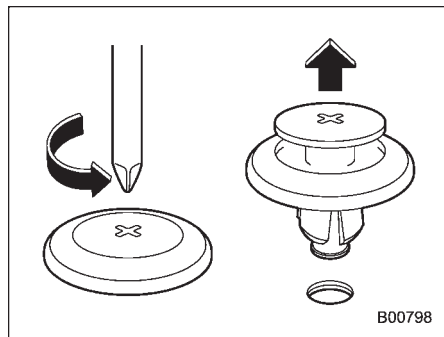

1. Turn the clip counterclockwise using a Phillips screwdriver until the center portion of the clip is raised.
2. Remove the entire clip by pulling it up.

▽ Reinstalling clips

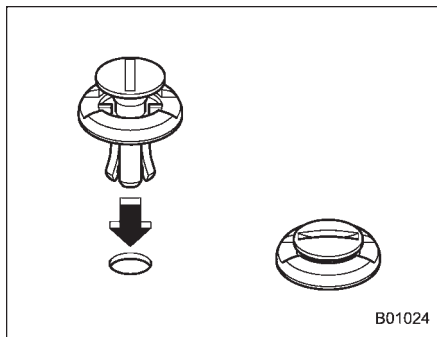

Type A clips

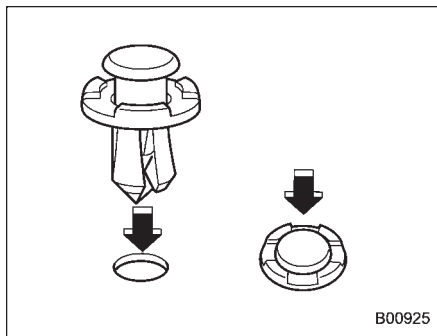

Type B clips

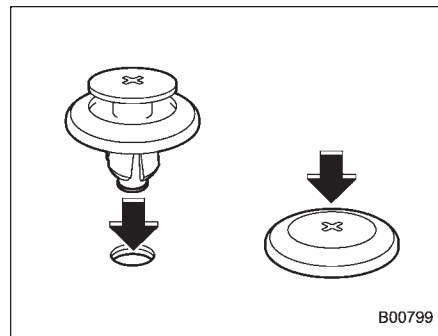

Type C clips

Insert the clip without the center portion first and then push the center portion of the clip into the hole.

■ Removing air intake duct

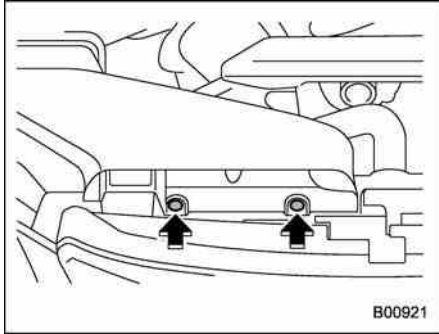

Use a screwdriver to undo the clips on the air intake duct, then remove the air intake duct. Refer to “Type A clips” 11-5.

■ Pulling off the fender lining

It is necessary to pull off the fender lining when replacing some bulbs.

1. Start the engine and turn the steering wheel fully in the opposite direction of the bulb to be replaced.
2. Stop the engine.

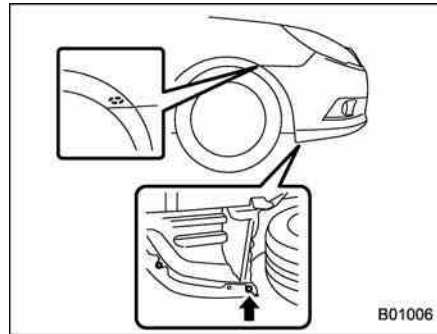

3. Remove the clip from the fender lining. Refer to “Type B clips” 11-5.

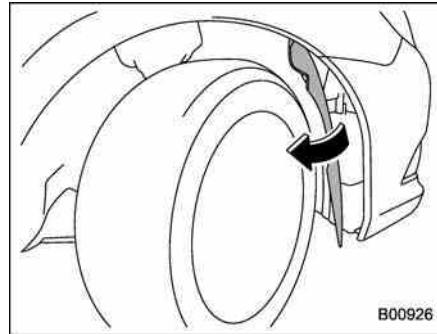

4. Pull off the fender lining.

Engine hood

To open the hood:

1. If the wiper blades are lifted off the windshield, return them to their original positions.

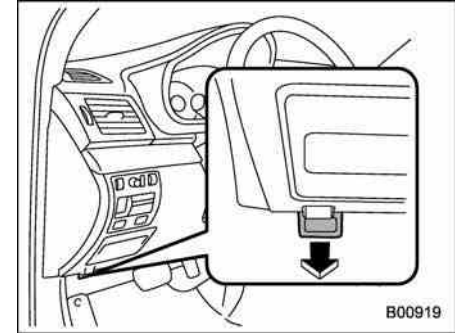

2. Pull the hood release knob under the instrument panel.

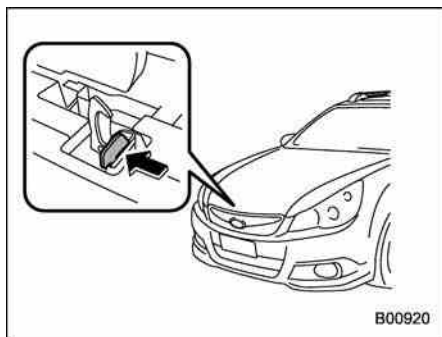

3. Release the secondary hood release by moving the lever between the front grille and the hood toward the left.
4. Lift up the hood.

To close the hood:

1. Lower the hood to a height of approximately 5.9 in (15 cm) above its closed position and then let it drop.
2. After closing the hood, be sure the hood is securely locked.

If this does not close the hood, release it from a slightly higher position. Do not push the hood forcibly to close it. It could deform the metal.



WARNING

Always check that the hood is properly locked before you start driving. If it is not, it might fly open while the vehicle is moving and block your view, which may cause an accident and serious bodily injury.

Engine compartment overview

■ 2.5 L non-turbo models

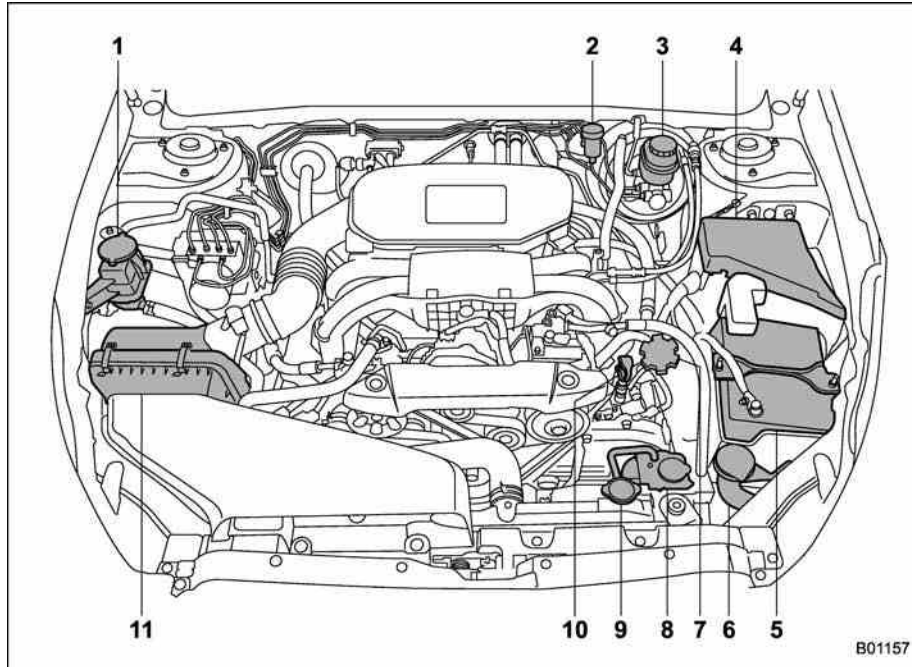

- 1) Power steering fluid reservoir (page 11-24)
- 2) Clutch fluid reservoir (page 11-26)
- 3) Brake fluid reservoir (page 11-25)
- 4) Fuse box (page 11-44)
- 5) Battery (page 11-43)
- 6) Windshield washer tank (page 11-37)
- 7) Engine oil filler cap (page 11-12)
- 8) Engine coolant reservoir (page 11-17)
- 9) Radiator cap (page 11-17)
- 10) Engine oil level gauge (page 11-12)
- 11) Air cleaner case (page 11-18)

B01157

■ 2.5 L turbo models

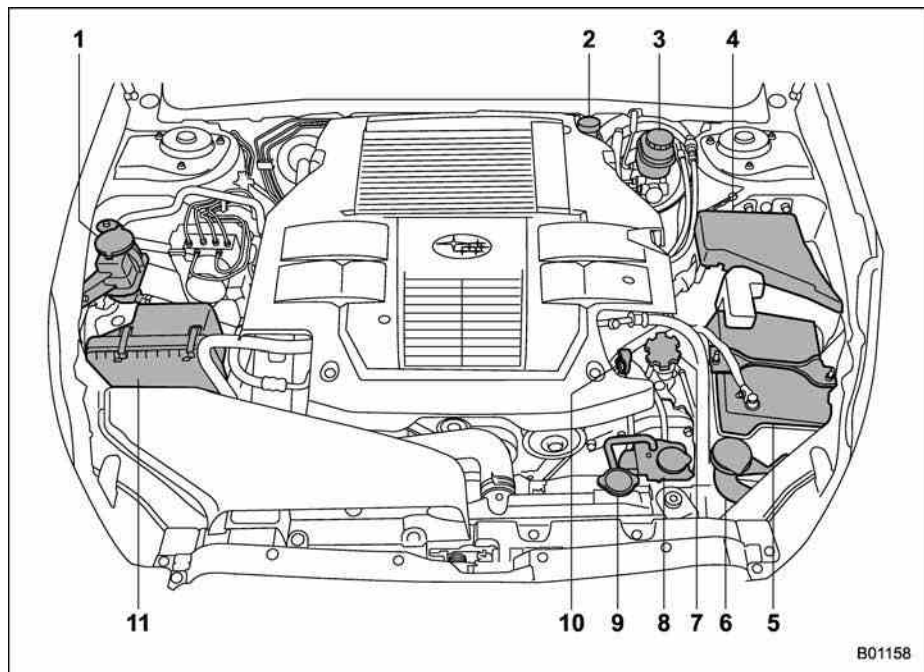

- 1) Power steering fluid reservoir (page 11-24)
- 2) Clutch fluid reservoir (page 11-26)
- 3) Brake fluid reservoir (page 11-25)
- 4) Fuse box (page 11-44)
- 5) Battery (page 11-43)
- 6) Windshield washer tank (page 11-37)
- 7) Engine oil filler cap (page 11-12)
- 8) Engine coolant reservoir (page 11-17)
- 9) Radiator cap (page 11-17)
- 10) Engine oil level gauge (page 11-12)
- 11) Air cleaner case (page 11-18)

B01158

■ 3.6 L models

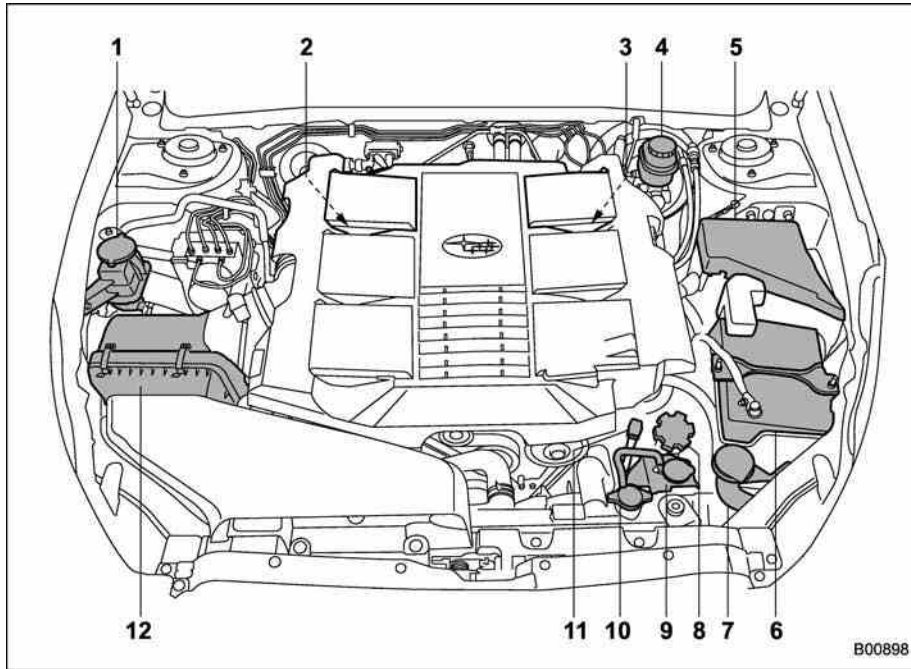

- 1) Power steering fluid reservoir (page 11-24)
- 2) Differential gear oil level gauge (page 11-23)
- 3) Automatic transmission fluid level gauge (page 11-21)
- 4) Brake fluid reservoir (page 11-25)
- 5) Fuse box (page 11-44)
- 6) Battery (page 11-43)
- 7) Windshield washer tank (page 11-37)
- 8) Engine oil filler cap (page 11-12)
- 9) Engine coolant reservoir (page 11-17)
- 10) Radiator cap (page 11-17)
- 11) Engine oil level gauge (page 11-12)
- 12) Air cleaner case (page 11-18)

B00898

Engine oil

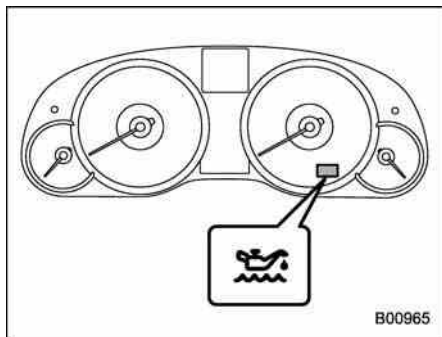

NOTE

- When the engine low oil level warning light illuminates, have your vehicle inspected by your SUBARU dealer as soon as possible.
- The engine oil consumption rate is not stabilized, and therefore cannot be determined until the vehicle has traveled at least several thousand miles (kilometers). Even after break-in, when the vehicle is used under severe driving conditions such as those mentioned in the Warranty and Maintenance Booklet, engine oil is consumed or deteriorated more quickly than under normal driving conditions. If you drive your vehicle under these severe

conditions, you should check the oil level at least at every second fuel fill-up time, and change the oil more frequently. Please refer to the Warranty and Maintenance Booklet for more details.

- If the oil consumption rate seems abnormally high after the break-in period, for example more than 1 quart per 1,200 miles or 1 liter per 2,000 kilometers, we recommend that you contact your SUBARU dealer.

■ Checking the oil level

Check the engine oil level at each fuel stop.

1. Park the vehicle on a level surface and stop the engine. If you check the oil level just after stopping the engine, wait a few minutes for the oil to drain back into the oil pan before checking the level.

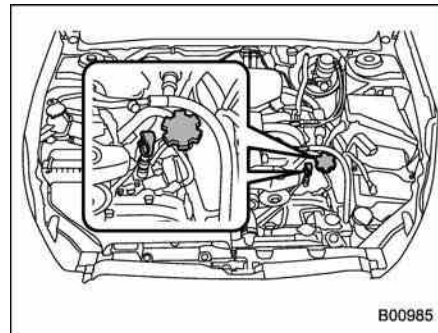

2. Pull out the level gauge, wipe it clean, and insert it again.
3. Be sure the level gauge is correctly inserted until it stops with the graphic symbol "油" on its top appearing as shown in the illustration.

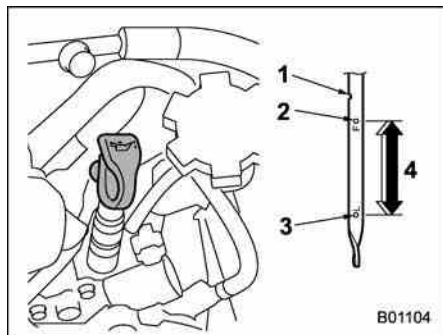
**2.5 L models**

- 1) Notch
- 2) Full level
- 3) Low level
- 4) Approximately 1.1 US qt (1.0 liter, 0.9 Imp qt) from low level to full level

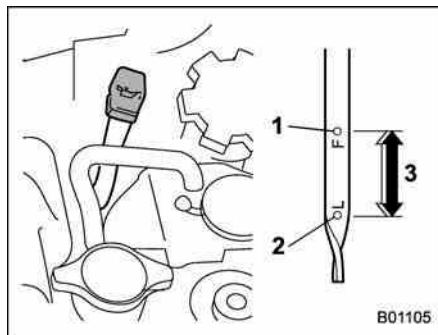
**3.6 L models**

- 1) Full level
- 2) Low level
- 3) Approximately 1.1 US qt (1.0 liter, 0.9 Imp qt) from low level to full level

4. Pull out the level gauge again and check the oil level on it. If it is below the low level (L), add oil to bring the level up to the full level (F).

**CAUTION**

- Use only engine oil with the recommended grade and viscosity.

- Be careful not to spill engine oil when adding it. If oil touches the exhaust pipe, it may cause a bad smell, smoke, and/or a fire. If engine oil gets on the exhaust pipe, be sure to wipe it off.

NOTE

- To prevent overfilling the engine oil, do not add any additional oil above the upper level when the engine is cold.
- In 2.5 L engine models, the level gauge has a notch above the upper level. Just after driving or while the engine is warm, the engine oil level reading may be in a range between the upper level and the notch mark. This is caused by thermal expansion of the engine oil.

■ Changing the oil and oil filter

⚠ CAUTION

- If you change your own oil, be sure to drain all the oil from the filter before disposal.
- Do not dispose of used engine oil by placing it in the trash, or by pouring it onto the ground, into sewers, or into any body of water. Check with your local government office for the proper disposal options available to you.

Change the oil and oil filter according to the maintenance schedule in the "Warranty and Maintenance Booklet".

The engine oil and oil filter must be changed more frequently than listed in the maintenance schedule when driving on dusty roads, when short trips are frequently made, or when driving in extremely cold weather.

1. Warm up the engine by letting the engine idle for approximately 10 minutes to ease draining the engine oil.
2. Park the vehicle on a level surface and stop the engine.
3. Remove the oil filler cap.

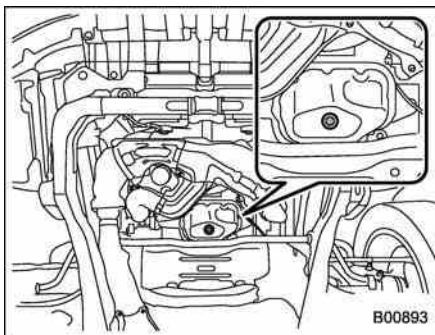

2.5 L non-turbo models

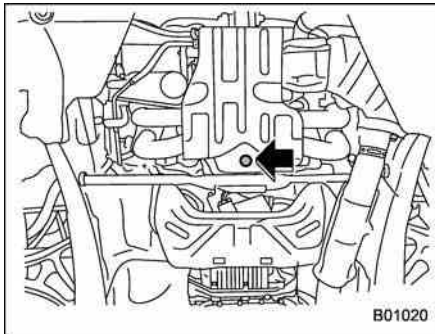

2.5 L turbo models

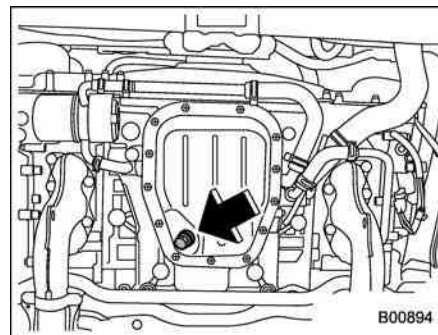

3.6 L models

4. Drain out the engine oil by removing the drain plug while the engine is still warm. The used oil should be drained into an appropriate container and disposed of properly.

⚠ WARNING

Be careful not to burn yourself with hot engine oil.

5. Wipe the seating surface and around the drain plug with a clean cloth and tighten it securely with a new sealing washer after the oil has completely drained out.

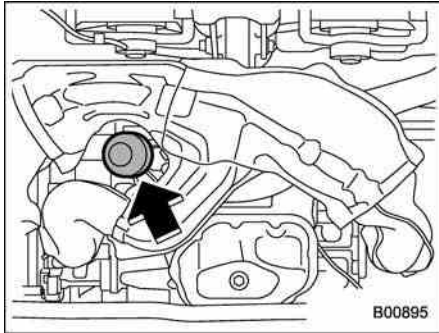
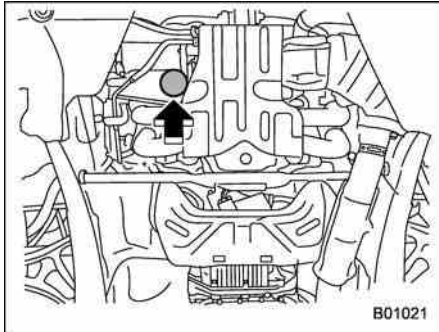
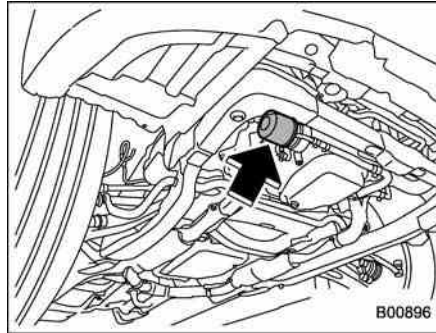
2.5 L non-turbo models

2.5 L turbo models

3.6 L models

6. Remove the oil filter with an oil filter wrench.
7. Before installing a new oil filter, apply a thin coat of engine oil to the seal.
8. Clean the rubber seal seating area of the bottom of engine and install the oil filter by hand turning. Be careful not to twist or damage the seal.
9. Tighten the oil filter by the amount indicated in the following table after the seal makes contact with the bottom of engine.

Model	Oil filter color	Part number	Amount of rotation
2.5 L models	Black	15208AA100	1 rotation
	Blue	15208AA12A	7/8 rotation
3.6 L models	Black	15208AA031	3/4 rotation

CAUTION

- **Never over tighten the oil filter because that can result in an oil leak.**
- **Thoroughly wipe off any engine oil that has spilled over the exhaust pipe and/or under-cover. If left unremoved, the oil could catch fire.**

10. Reinstall the cover under the oil filter.
11. Pour engine oil through the filler neck. For the oil capacity (guideline), refer to "Engine oil" 12-4. The necessary quantity of oil depends on the quantity of oil that has been drained. The quantity of drained oil differs slightly depending on the temperature of the oil and the time the oil is left flowing out. After refilling the engine with oil, therefore, you must use the level gauge to confirm that the level is correct.

12. Start the engine and make sure that no oil leaks appear around the filter's rubber seal and drain plug.

13. Keep the engine idling until the engine reaches the normal operating temperature range, as indicated by the temperature gauge on the combination meter. After that, check the engine oil level again. For further details about the check procedure, refer to "Checking the oil level" 11-12.

■ Recommended grade and viscosity



Use only engine oil with the recommended grade and viscosity.

Refer to "Engine oil" 12-4.

NOTE

Engine oil viscosity (thickness) affects fuel economy. Oils of lower viscosity provide better fuel economy. However, in hot weather, oil of higher viscosity is required to properly lubricate the engine.

■ Synthetic oil

You should use synthetic engine oil that meets the same requirements given for

conventional engine oil. When using synthetic oil, you must use oil of the same classification, viscosity and grade shown in this Owner's Manual. Refer to "Engine oil" 12-4. Also, you must follow the oil and filter changing intervals shown in the Warranty and Maintenance booklet.

NOTE

Synthetic oil of the grade and viscosity noted in chapter 12 is the recommended engine oil for optimum engine performance. Conventional oil may be used if synthetic oil is unavailable.

Cooling system



Never attempt to remove the radiator cap until the engine has been shut off and has cooled down completely. Since the coolant is under pressure, you may suffer serious burns from a spray of boiling hot coolant when the cap is removed.



- Vehicles are filled at the factory with SUBARU Super Coolant that does not require the first change for 11 years/137,500 miles (11 years/220,000 km). This coolant should not be mixed with any other brand or type of coolant during this period. Mixing with a different coolant will reduce the life of the coolant. Should it be necessary to top off the coolant for any reason, use only SUBARU Super Coolant.

If the SUBARU Super Coolant is diluted with another brand or type, the maintenance interval is

shortened to that of the mixing coolant.

- Do not splash the engine coolant over painted parts. The alcohol contained in the engine coolant may damage the paint surface.

■ Cooling fan, hose and connections

Your vehicle employs an electric cooling fan which is thermostatically controlled to operate when the engine coolant reaches a specific temperature.

If the radiator cooling fan does not operate even when the coolant temperature high warning light illuminates, the cooling fan circuit may be defective. Check the fuse and replace it if necessary. Refer to "Fuses" 11-44 and "Fuses and circuits" 12-10. If the fuse is not blown, have the cooling system checked by your SUBARU dealer.

If frequent addition of coolant is necessary, there may be a leak in the engine cooling system. It is recommended that the cooling system and connections be checked for leaks, damage, or looseness.

■ Engine coolant

▼ Checking the coolant level

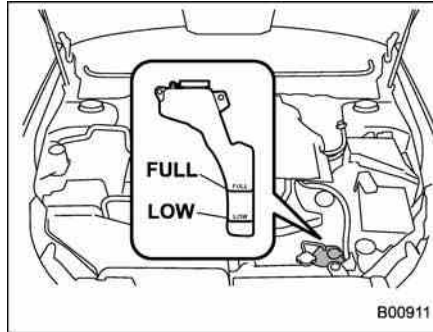

Check the coolant level at each fuel stop.

1. Check the coolant level on the outside of the reservoir while the engine is cool.
2. If the level is close to or lower than the "LOW" level mark, add coolant up to the "FULL" level mark. If the reserve tank is empty, remove the radiator cap and refill as required.
3. After refilling the reserve tank and the radiator, reinstall the caps and check that the rubber gaskets inside the radiator cap are in the proper position.

⚠ CAUTION

- Be careful not to spill engine coolant when adding it. If coolant touches the exhaust pipe, it may cause a bad smell, smoke, and/or a fire. If engine coolant gets on the exhaust pipe, be sure to wipe it off.
- Do not splash the engine coolant over painted parts. The alcohol contained in the engine coolant may damage the paint surface.

▼ Changing the coolant

It may be difficult to change the coolant. Have the coolant changed by your SUBARU dealer if necessary.

The coolant should be changed according to the maintenance schedule in the "Warranty and Maintenance Booklet".

Air cleaner element

WARNING

Do not operate the engine with the air cleaner element removed. The air cleaner element not only filters intake air but also stops flames if the engine backfires. If the air cleaner element is not installed when the engine backfires, you could be burned.

CAUTION

When replacing the air cleaner element, use a genuine SUBARU air cleaner element. If it is not used, there is the possibility of causing a negative effect to the engine.

The air cleaner element functions as a filter screen. When the element is perforated or removed, engine wear will be excessive and engine life shortened.

The air cleaner element is a dry type. It is unnecessary to clean or wash the element.

■ Replacing the air cleaner element

Replace the air cleaner element according to the maintenance schedule in the "Warranty and Maintenance Booklet". Under extremely dusty conditions, replace it more frequently. It is recommended that you always use genuine SUBARU parts.

▼ Non-turbo models

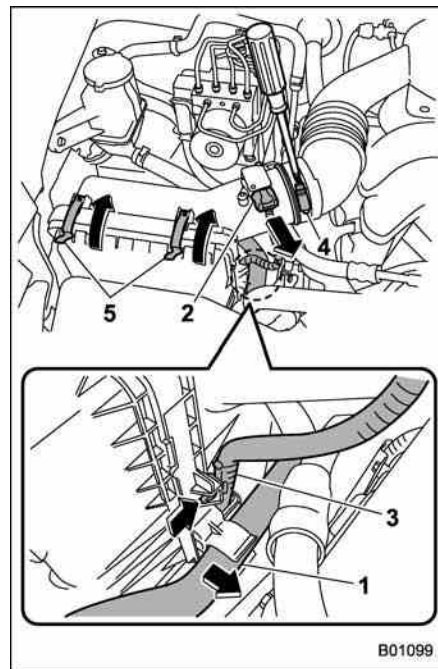

- 1) Hydraulic hose
- 2) Connector
- 3) Connector cable
- 4) Clamp
- 5) Clips

B01099

1. Remove the hydraulic hose in the power steering system from the clip on the right side of the air cleaner case.
2. Unplug the connector that is attached to the top of the air cleaner case.
3. To remove the connector cable from the air cleaner case, remove the clip that is attached to the connector cable from the guide lug on the right side of the air cleaner case.
4. Loosen the screw on the clamp.
5. Unsnap the two clips holding the air cleaner case cover.

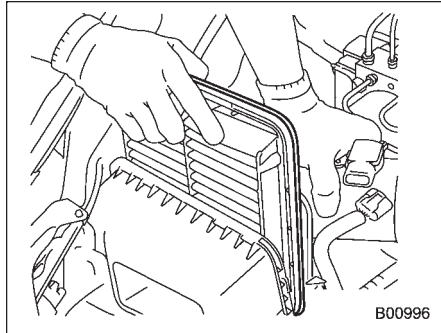

6. Open the air cleaner case and remove the air cleaner element.
7. Clean the inside of the air cleaner case and case cover with a damp cloth and install a new air cleaner element.

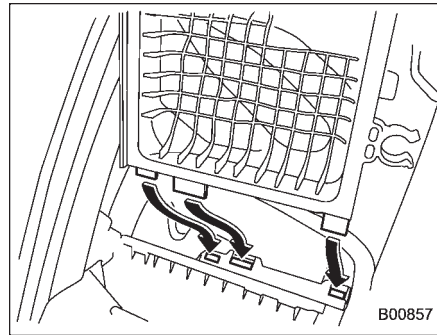

8. To install the air cleaner case, insert the three projections on the air cleaner case into the slits on the air cleaner case cover.
9. Install the removed or loosened parts in the reverse order of removal.

▼ **Turbo models**

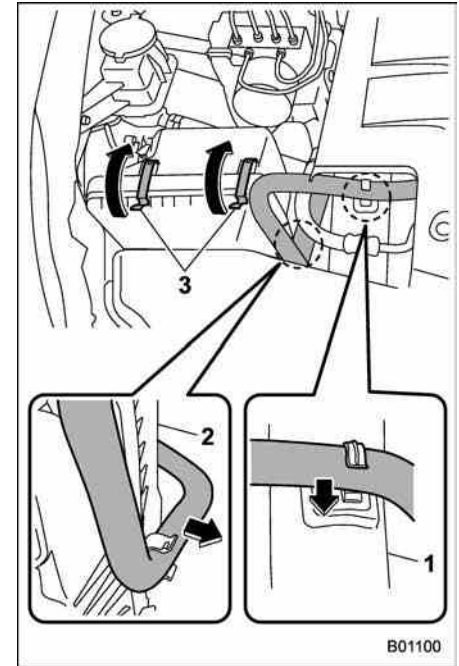

- 1) Air intake duct
- 2) Air cleaner case
- 3) Clamp

1. Remove the hydraulic hose in the power steering system from the clip on

the air intake duct.

2. Remove the hydraulic hose from the clip on the right side of the air cleaner case.
3. Unsnap the two clamps holding the air cleaner case cover.

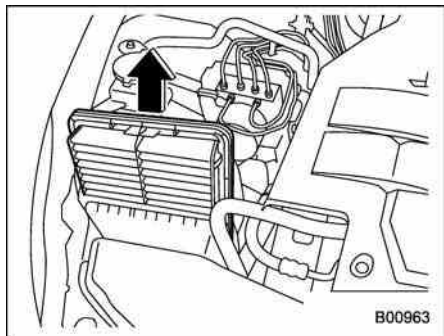

4. Open the air cleaner case and remove the air cleaner element.
5. Clean the inside of the air cleaner case and case cover with a damp cloth and install a new air cleaner element.

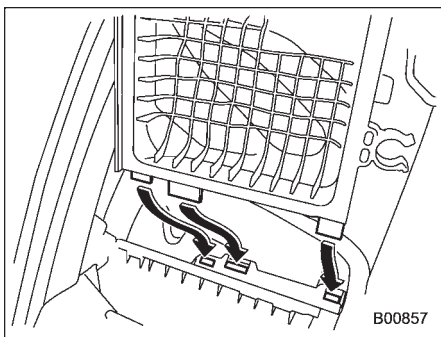

6. If the air cleaner case has been removed, insert the three projections on the air cleaner case into the slits on the air cleaner case cover.
7. Install the removed parts in the reverse order of removal.

Spark plugs

It may be difficult to replace the spark plugs. It is recommended that you have the spark plugs replaced by your SUBARU dealer.

The spark plugs should be replaced according to the maintenance schedule in the "Warranty and Maintenance Booklet".

■ Recommended spark plugs

Refer to "Electrical system" ⌚ 12-9.

Drive belts

It is unnecessary to check the deflection of the drive belt periodically because your engine is equipped with an automatic belt tension adjuster. However, replacement of the belt should be done according to the maintenance schedule in the “Warranty and Maintenance Booklet”. Consult your SUBARU dealer for replacement.

If the belt is loose, cracked or worn, contact your SUBARU dealer.

Manual transmission oil

It is unnecessary to check the manual transmission oil level. However, if necessary, consult your SUBARU dealer for inspection.

■ Recommended grade and viscosity

Each oil manufacturer has its own base oils and additives. Never use different brands together. For details, refer to “Manual transmission, front differential and rear differential gear oil”  12-7.

Automatic transmission fluid

■ Checking the fluid level

The automatic transmission fluid expands largely as its temperature rises; the fluid level differs according to fluid temperature. Therefore, there are two different scales for checking the level of hot fluid and cold fluid on the level gauge.

Though the fluid level can be checked without warming up the fluid on the “COLD” range, we recommend checking the fluid level when the fluid is at operating temperature.

▼ Checking the fluid level when the fluid is hot

Check the fluid level monthly.

1. Drive the vehicle several miles to raise the temperature of the transmission fluid up to normal operating temperature; 158 to 176°F (70 to 80°C) is normal.
2. Park the vehicle on a level surface and set the parking brake.
3. First shift the select lever in each position. Then shift it in the “P” position, and run the engine at idling speed.

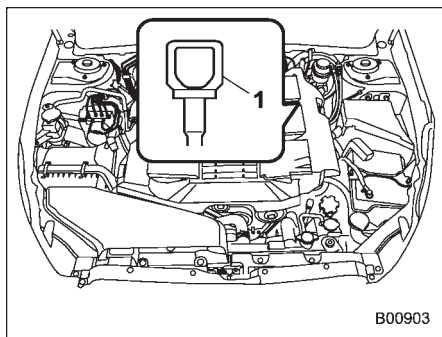

B00903

- 1) Yellow handle

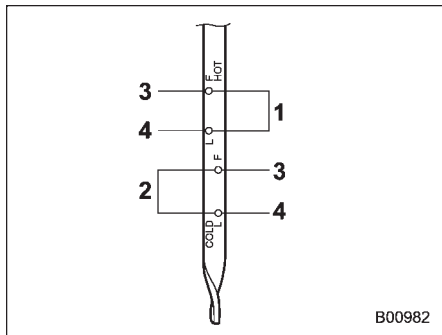

B00982

- 1) HOT range
 - 2) COLD range
 - 3) Upper level
 - 4) Lower level
4. Pull out the level gauge and check the

fluid level on the gauge. If it is below the lower level on the "HOT" range, add the recommended automatic transmission fluid up to the upper level.

▼ **Checking the fluid level when the fluid is cold**

When the fluid level has to be checked without time to warm up the automatic transmission, check to see that the fluid level is between the lower level and upper level on the "COLD" range. If it is below that range, add fluid up to the upper level. Be careful not to overfill.



CAUTION

Be careful not to spill automatic transmission fluid when adding it. If automatic transmission fluid touches the exhaust pipe, it may cause a bad smell, smoke, and/or a fire. If automatic transmission fluid gets on the exhaust pipe, be sure to wipe it off.

■ **Recommended fluid**

Refer to "Fluids" 12-8.

NOTE

Using any non-specified type of automatic transmission fluid could result in damage inside the transmission. When replacing the automatic transmission fluid, be sure to use the specified type.

Continuously variable transmission fluid

There is no fluid level gauge. It is unnecessary to check the continuously variable transmission fluid level. However, if necessary, consult your SUBARU dealer for inspection.

Front differential gear oil (AT and CVT models)

■ Checking the oil level

▼ AT models

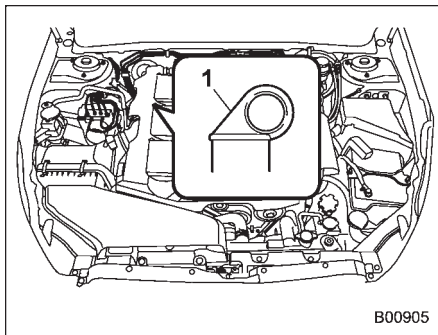

1) Yellow handle

1. Park the vehicle on a level surface and stop the engine.
2. Pull out the level gauge, wipe it clean, and insert it again.

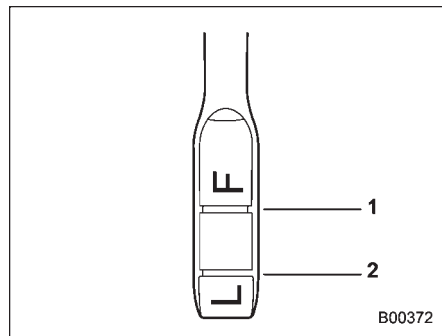

- 1) Upper level
- 2) Lower level

3. Pull out the level gauge again and check the oil level on it. If it is below the lower level, add oil to bring the level up to the upper level.



CAUTION

Be careful not to spill front differential gear oil when adding it. If oil touches the exhaust pipe, it may cause a bad smell, smoke, and/or a fire. If oil gets on the exhaust pipe, be sure to wipe it off.

▼ CVT models

There is no oil level gauge. To check the front differential gear oil level, we recommend that you consult your SUBARU dealer for inspection.

■ Recommended grade and viscosity

Each oil manufacturer has its own base oils and additives. Never use different brands together. For details, refer to "Manual transmission, front differential and rear differential gear oil" 12-7.

Rear differential gear oil

There is no oil level gauge. To check the rear differential gear oil level, we recommend that you consult your SUBARU dealer for inspection.

■ Recommended grade and viscosity

Each oil manufacturer has its own base oils and additives. Never use different brands together. For details, refer to "Manual transmission, front differential and rear differential gear oil" 12-7.

Power steering fluid

■ Checking the fluid level

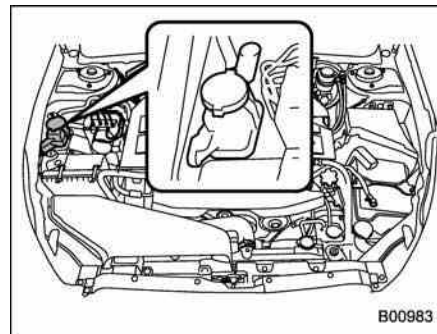

WARNING

Be careful not to burn yourself because the fluid may be hot.



CAUTION

- When power steering fluid is being added, use only clean fluid, and be careful not to allow any dirt into the tank. And never use different brands together.
- Be careful not to spill power steering fluid when adding it. If

power steering fluid touches the exhaust pipe, it may cause a bad smell, smoke, and/or a fire. If power steering fluid gets on the exhaust pipe, be sure to wipe it off.

The power steering fluid expands greatly as its temperature rises; the fluid level differs according to fluid temperature. Therefore, the reservoir tank has two different checking ranges for hot and cold fluids.

Check the power steering fluid level monthly.

1. Park the vehicle on a level surface, and stop the engine.

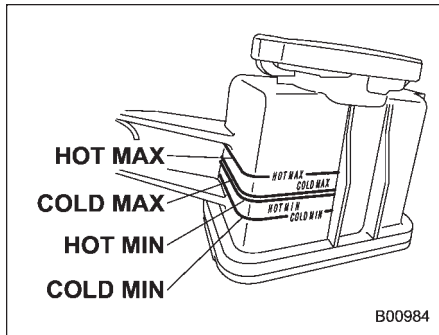

2. Check the fluid level of the reservoir

tank.

When the fluid is hot after the vehicle has been run: Check that the oil level is between "HOT MIN" and "HOT MAX" on the surface of the reservoir tank.

When the fluid is cool before the vehicle is run: Check that the oil level is between "COLD MIN" and "COLD MAX" on the surface of the reservoir tank.

3. If the fluid level is lower than the applicable "MIN" line, add the recommended fluid as necessary to bring the level between the "MIN" and "MAX" line.

If the fluid level is extreme low, it may indicate possible leakage. Consult your SUBARU dealer for inspection.

■ Recommended fluid

Refer to "Fluids" 12-8.

Brake fluid

■ Checking the fluid level

⚠ WARNING

- Never let brake fluid contact your eyes because brake fluid can be harmful to your eyes. If brake fluid gets in your eyes, immediately flush them thoroughly with clean water. For safety, when performing this work, wearing eye protection is advisable.
- Brake fluid absorbs moisture from the air. Any absorbed moisture can cause a dangerous loss of braking performance.
- If the vehicle requires frequent refilling, there may be a leak. If you suspect a problem, have the vehicle checked at your SUBARU dealer.

⚠ CAUTION

- When adding brake fluid, be careful not to allow any dirt into the reservoir.
- Never splash the brake fluid over painted surfaces or rubber parts.

Alcohol contained in the brake fluid may damage them.

- Be careful not to spill brake fluid when adding it. If brake fluid touches the exhaust pipe, it may cause a bad smell, smoke, and/or a fire. If brake fluid gets on the exhaust pipe, be sure to wipe it off.

Check the fluid level monthly.

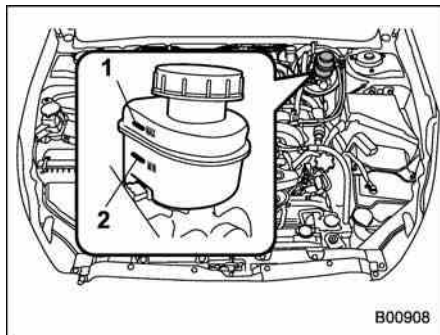

- 1) "MAX" level mark
- 2) "MIN" level mark

Check the fluid level on the outside of the reservoir. If the level is below "MIN", add the recommended brake fluid to "MAX".

Use only brake fluid from a sealed container.

■ Recommended brake fluid

Refer to "Fluids" 12-8.

⚠ CAUTION

Never use different brands of brake fluid together. Also, avoid mixing DOT 3 and DOT 4 brake fluids even if they are the same brand.

Clutch fluid (MT models)

■ Checking the fluid level

⚠ WARNING

Never let clutch fluid contact your eyes because clutch fluid can be harmful to your eyes. If clutch fluid gets in your eyes, immediately flush them thoroughly with clean water. For safety, when performing this work, wearing eye protection is advisable.

⚠ CAUTION

- Clutch fluid absorbs moisture from the air. Any absorbed moisture can cause improper clutch operation.
- If the vehicle requires frequent refilling, there may be a leak. If you suspect a problem, have the vehicle checked at your SUBARU dealer.
- When clutch fluid is added, be careful not to allow any dirt into the tank.
- Never splash the clutch fluid over painted surfaces or rubber parts.

Alcohol contained in the clutch fluid may damage them.

- Be careful not to spill clutch fluid when adding it. If clutch fluid touches the exhaust pipe, it may cause a bad smell, smoke, and/or a fire. If clutch fluid gets on the exhaust pipe, be sure to wipe it off.

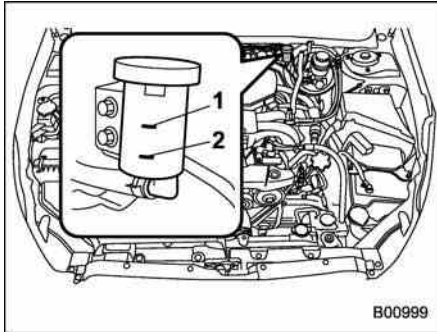

- 1) "MAX" level mark
- 2) "MIN" level mark

Check the fluid level on the outside of the reservoir. If the level is below "MIN" level mark, add the recommended clutch fluid to "MAX" level mark.

Use only clutch fluid from a sealed container.

■ Recommended clutch fluid

Refer to "Fluids" 12-8.

⚠ CAUTION

Never use different brands of clutch fluid together. Also, avoid mixing DOT 3 and DOT 4 brake fluids even if they are the same brand.

Brake booster

If the brake booster does not operate as described in the following procedure, have it checked by your SUBARU dealer.

1. With the engine off, depress the brake pedal several times, applying the same pedal force each time. The distance the pedal travels should not vary.
2. With the brake pedal depressed, start the engine. The pedal should move slightly down to the floor.
3. With the brake pedal depressed, stop the engine and keep the pedal depressed for 30 seconds. The pedal height should not change.
4. Start the engine again and run for approximately 1 minute then turn it off. Depress the brake pedal several times to check the brake booster. The brake booster operates properly if the pedal stroke decreases with each depression.

NOTE

When you depress the brake pedal strongly or suddenly, the following phenomena occur. However, even though these occur, they do not indicate any malfunctions, and the brake assist system is operating properly.

- You might feel that the brake pedal

is applied by lighter force and generates a greater braking force.

- You might hear the sound of ABS operating from the engine compartment.

Brake assist is not a system that brings more braking ability to the vehicle beyond its breaking capability.

Brake pedal

Check the brake pedal free play and reserve distance according to the maintenance schedule in the "Warranty and Maintenance Booklet".

■ Checking the brake pedal free play

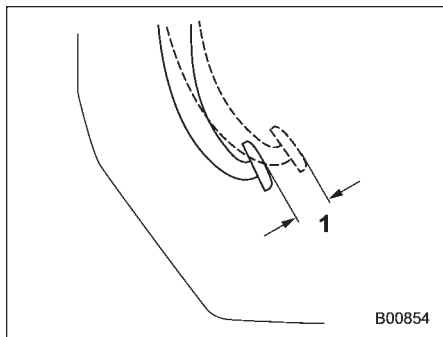

1) 0.08 – 0.18 in (2 – 5 mm)

Stop the engine and firmly depress the brake pedal several times. Lightly pull the brake pedal up with one finger to check the free play with a force of less than 2 lbf (10 N, 1 kgf).

If the free play is not within proper specification, contact your SUBARU dealer.

■ Checking the brake pedal reserve distance

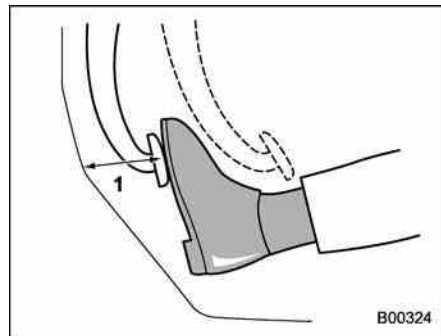

1) More than 2.56 in (65 mm)

Depress the pedal with a force of approximately 66 lbf (294 N, 30 kgf) and measure the distance between the upper surface of the pedal pad and the floor.

When the measurement is smaller than the specification, or when the pedal does not operate smoothly, contact with your SUBARU dealer.

Clutch pedal (MT models)

Check the clutch pedal free play and reserve distance according to the maintenance schedule in the "Warranty and Maintenance Booklet".

■ Checking the clutch function

Check the clutch engagement and disengagement.

1. With the engine idling, check that there are no abnormal noises when the clutch pedal is depressed, and that shifting into 1st or reverse feels smooth.
2. Start the vehicle by releasing the pedal slowly to check that the engine and transmission smoothly couple without any sign of slippage.

■ Checking the clutch pedal free play

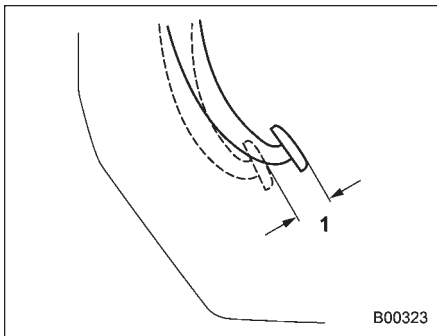

1) 0.19 – 0.44 in (5 – 11 mm)

Lightly press the clutch pedal down with your finger until you feel resistance, and check the free play.

If the free play is not within proper specification, contact your SUBARU dealer.

Replacement of brake pad and lining

⚠ CAUTION

If you continue to drive despite the scraping noise from the audible brake pad wear indicator, it will result in the need for costly brake rotor repair or replacement.

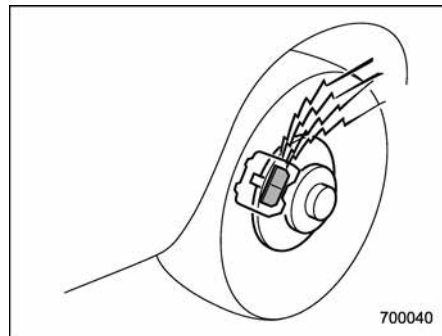

The disc brakes have audible wear indicators on the brake pads. If the brake pads wear close to their service limit, the wear indicator makes a very audible scraping noise when the brake pedal is applied.

If you hear this scraping noise each time

you apply the brake pedal, have the brake pads serviced by your SUBARU dealer as soon as possible.

■ **Breaking-in of new brake pads and linings**

When replacing the brake pad or lining, use only genuine SUBARU parts. After replacement, the new parts must be broken in as follows:

▼ **Brake pad and lining**

While maintaining a speed of 30 to 40 mph (50 to 65 km/h), step on the brake pedal lightly. Repeat this five or more times.

▼ **Parking brake lining**

The break-in maintenance for the parking brake linings should be performed at a SUBARU dealer.

Tires and wheels

■ **Types of tires**

You should be familiar with type of tires present on your vehicle.

▼ **All season tires**

The factory-installed tires on your new vehicle except 2.5 L turbo models are all season tires.

All season tires are designed to provide an adequate measure of traction, handling and braking performance in year-round driving including snowy and icy road conditions. However all season tires do not offer as much traction performance as winter (snow) tires in heavy or loose snow or on icy roads.

All season tires are identified by "ALL SEASON" and/or "M+S" (Mud & Snow) on the tire sidewall.

▼ **Summer tires**

The factory-installed tires on your new 2.5 L turbo models are summer tires. Summer tires are high-speed capability tires best suited for highway driving under dry conditions.

Summer tires are inadequate for driving on slippery roads such as on snow-covered or icy roads.

If you drive your vehicle on snow-covered

or icy roads, we strongly recommend the use of winter (snow) tires.

When installing winter tires, be sure to replace all four tires.

▼ **Winter (snow) tires**

Winter tires are best suited for driving on snow-covered and icy roads. However winter tires do not perform as well as summer tires and all season tires on roads other than snow-covered and icy roads.

■ **Tire pressure monitoring system (TPMS) (if equipped)**

The tire pressure monitoring system provides the driver with a warning message by sending a signal from a sensor that is installed in each wheel when tire pressure is severely low. The tire pressure monitoring system will activate only when the vehicle is driven. Also, this system may not react immediately to a sudden drop in tire pressure (for example, a blow-out caused by running over a sharp object).

If you adjust the tire pressures in a warm garage and will then drive the vehicle in cold outside air, the resulting drop in tire pressures may cause the low tire pressure warning light to illuminate. To avoid this problem when adjusting the tire pressures in a warm garage, inflate the tires to pressures higher than those shown on the

tire placard. Specifically, inflate them by an extra 1 psi (6.9 kPa, 0.07 kgf/cm²) for every difference of 10°F (5.6°C) between the temperature in the garage and the temperature outside. By way of example, the following table shows the required tire pressures that correspond to various outside temperatures when the temperature in the garage is 60°F (15.6°C).

Example:

Tire size: P215/70R16 99S, P225/60R17 98T

Standard tire pressures:

Front: 32 psi (220 kPa, 2.2 kgf/cm²)

Rear: 30 psi (210 kPa, 2.1 kgf/cm²)

Garage temperature: 60°F (15.6°C)

Outside temperature	Adjusted pressure [psi (kPa, kgf/cm ²)]	
	Front	Rear
30°F (-1°C)	35 (240, 2.4)	33 (230, 2.3)
10°F (-12°C)	37 (255, 2.55)	35 (240, 2.4)
-10°F (-23°C)	39 (270, 2.7)	37 (255, 2.55)

Example:

Tire size: P205/60R16 91V, P215/50R17 90V, P225/50R17 93V, 225/45R18 91W

Standard tire pressures:

Front: 33 psi (230 kPa, 2.3 kgf/cm²)

Rear: 32 psi (220 kPa, 2.2 kgf/cm²)

Garage temperature: 60°F (15.6°C)

Outside temperature	Adjusted pressure [psi (kPa, kgf/cm ²)]	
	Front	Rear
30°F (-1°C)	36 (250, 2.5)	35 (240, 2.4)
10°F (-12°C)	38 (265, 2.65)	37 (255, 2.55)
-10°F (-23°C)	40 (280, 2.8)	39 (270, 2.7)

If the low tire pressure warning light illuminates when you drive the vehicle in cold outside air after adjusting the tire pressures in a warm garage, re-adjust the tire pressures using the method described above. Then, increase the vehicle speed to at least 20 mph (32 km/h) and check to see that the low tire pressure warning light goes off a few minutes later. If the low tire pressure warning light does not go off, the tire pressure monitoring system may not be functioning normally. In this event, go to a SUBARU dealer to have the system inspected as soon as possible.

While the vehicle is driven, friction between tires and the road surface causes the tires to warm up. After illumination of the low tire pressure warning light, any increase in the tire pressures caused by an increase in the outside air temperature

or by an increase in the temperature in the tires can cause the low tire pressure warning light to go off.

System resetting is necessary when the wheels are changed (for example, a switch to snow tires) and new TPMS valves are installed on the newly fitted wheels. Have this work performed by a SUBARU dealer following wheel replacement.

It may not be possible to install TPMS valves on certain wheels that are on the market. Therefore, if you change the wheels (for example, a switch to snow tires), use wheels that have the same part number as the standard-equipment wheels. Without four operational TPMS valve/sensors on the wheels, the TPMS will not fully function and the warning light in the instrument panel will illuminate steadily after blinking for approximately one minute.

When a tire is replaced, adjustments are necessary to ensure continued normal operation of the tire pressure monitoring system. As with wheel replacement, therefore, you should have the work performed by a SUBARU dealer.

**WARNING**

If the low tire pressure warning light does not illuminate briefly after the ignition switch is turned ON or the light illuminates steadily after blinking for approximately one minute, you should have your Tire Pressure Monitoring System checked at a SUBARU dealer as soon as possible.

If this light illuminates while driving, never brake suddenly and keep driving straight ahead while gradually reducing speed. Then slowly pull off the road to a safe place. Otherwise an accident involving serious vehicle damage and serious personal injury could occur.

If this light still illuminates while driving after adjusting the tire pressure, a tire may have significant damage and a fast leak that causes the tire to lose air rapidly. If you have a flat tire, replace it with a spare tire as soon as possible.

When a spare tire is mounted or a wheel rim is replaced without the original pressure sensor/transmitter being transferred, the low tire pressure warning light will illuminate steadily after blinking for approxi-

mately one minute. This indicates the TPMS is unable to monitor all four road wheels. Contact your SUBARU dealer as soon as possible for tire and sensor replacement and/or system resetting. If the light illuminates steadily after blinking for approximately one minute, promptly contact a SUBARU dealer to have the system inspected.

■ Tire inspection

Check on a daily basis that the tires are free from serious damage, nails, and stones. At the same time, check the tires for abnormal wear.

Contact your SUBARU dealer immediately if you find any problem.

NOTE

- When the wheels and tires strike curbs or are subjected to harsh treatment as when the vehicle is driven on a rough surface, they can suffer damage that cannot be seen with the naked eye. This type of damage does not become evident until time has passed. Try not to drive over curbs, potholes or on other rough surfaces. If doing so is unavoidable, keep the vehicle's speed down to a walking pace or less, and

approach the curbs as squarely as possible. Also, make sure the tires are not pressed against the curb when you park the vehicle.

- If you feel unusual vibration while driving or find it difficult to steer the vehicle in a straight line, one of the tires and/or wheels may be damaged. Drive slowly to the nearest authorized SUBARU dealer and have the vehicle inspected.

■ Tire pressures and wear

Maintaining the correct tire pressures helps to maximize the tires' service lives and is essential for good running performance. Check and, if necessary, adjust the pressure of each tire (including the spare) at least once a month (for example, during a fuel stop) and before any long journey.

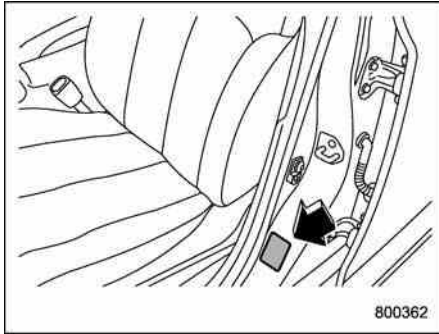

Check the tire pressures when the tires are cold. Use a pressure gauge to adjust the tire pressures to the values shown on the tire placard. The tire placard is located on the door pillar on the driver's side.

Driving even a short distance warms up the tires and increases the tire pressures. Also, the tire pressures are affected by the outside temperature. It is best to check tire pressure outdoors before driving the vehicle.

When a tire becomes warm, the air inside it expands, causing the tire pressure to increase. Be careful not to mistakenly release air from a warm tire to reduce its pressure.

NOTE

- The air pressure in a tire increases by approximately 4.3 psi (30 kPa, 0.3 kgf/cm²) when the tire becomes warm.
- The tires are considered cold when the vehicle has been parked for at least 3 hours or has been driven less than 1 mile (1.6 km).



WARNING

Do not let air out of warm tires to adjust pressure. Doing so will result in low tire pressure.

Incorrect tire pressures detract from controllability and ride comfort, and they cause the tires to wear abnormally.

- **Correct tire pressure** (tread worn evenly)

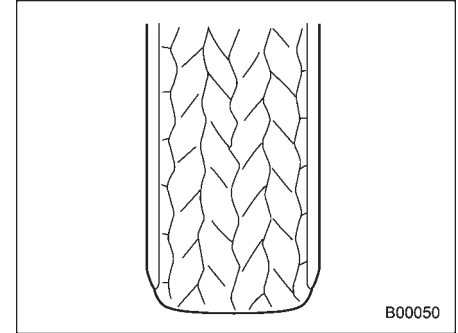

Roadholding is good, and steering is responsive. Rolling resistance is low, so fuel consumption is also lower.

- **Abnormally low tire pressure** (tread worn at shoulders)

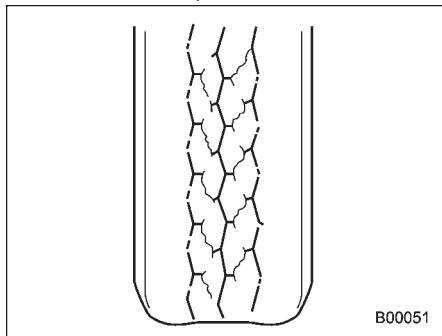

Rolling resistance is high, so fuel consumption is also higher.

- **Abnormally high tire pressure** (tread worn in center)

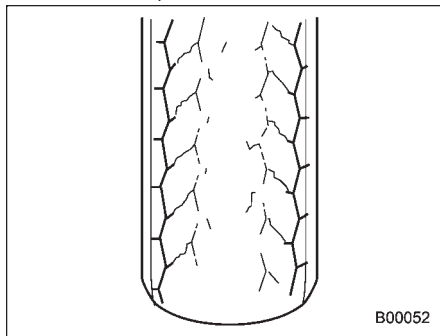

Ride comfort is poor. Also, the tire magnifies the effects of road surface bumps and dips, possibly resulting in vehicle damage.

WARNING

Driving at high speeds with excessively low tire pressures can cause the tires to deform severely and to rapidly become hot. A sharp increase in temperature could cause tread separation, and destruction of the tires. The resulting loss of vehicle control could lead to an accident.

■ **Wheel balance**

Each wheel was correctly balanced when your vehicle was new, but the wheels will become unbalanced as the tires become worn during use. Wheel imbalance causes the steering wheel to vibrate slightly at certain vehicle speeds and detracts from the vehicle's straight-line stability. It can also cause steering and suspension system problems and abnormal tire wear. If you suspect that the wheels are not correctly balanced, have them checked and adjusted by your SUBARU dealer. Also have them adjusted after tire repairs and after tire rotation.

CAUTION

Loss of correct wheel alignment causes the tires to wear on one side and reduces the vehicle's running stability. Contact your SUBARU dealer if you notice abnormal tire wear.

NOTE

The suspension system is designed to hold each wheel at a certain alignment (relative to the other wheels and to the road) for optimum straight-line stability and cornering performance.

■ Wear indicators

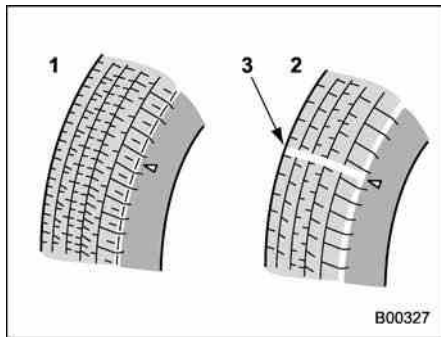

B00327

- 1) New tread
- 2) Worn tread
- 3) Tread wear indicator

Each tire incorporates a tread wear indicator, which becomes visible when the depth of the tread grooves decreases to 0.063 in (1.6 mm). A tire must be replaced when the tread wear indicator appears as a solid band across the tread.

WARNING

When a tire's tread wear indicator becomes visible, the tire is worn beyond the acceptable limit and must be replaced immediately. With a tire in this condition, driving at high speeds in wet weather can

cause the vehicle to hydroplane. The resulting loss of vehicle control can lead to an accident.

NOTE

For safety, inspect the tire tread regularly and replace the tires before their tread wear indicators become visible.

■ Tire rotation direction mark

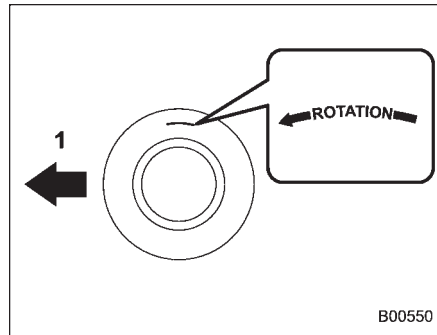

B00550

Example of tire rotation direction mark

- 1) Front

If the tire has a rotation direction specification, the tire rotation direction mark is placed on its sidewall.

When you install a tire that has the tire rotation direction mark, install the tire with

the direction mark facing forward.

■ Tire rotation

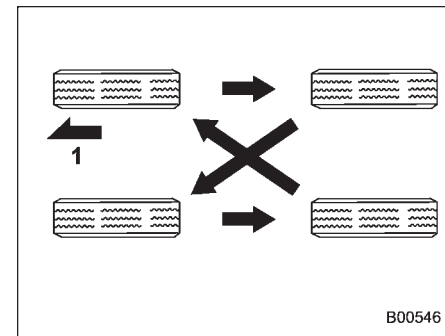

B00546

Vehicles equipped with 4 non-unidirectional tires

- 1) Front

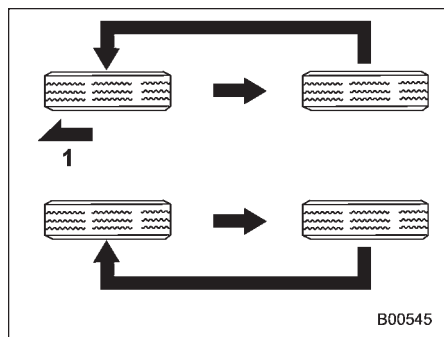

Vehicles equipped with unidirectional tires

1) Front

Tire wear varies from wheel to wheel. To maximize the life of each tire and ensure that the tires wear uniformly, it is best to rotate the tires every 7,500 miles (12,000 km). Move the tires to the positions shown in the applicable illustration each time they are rotated.

Replace any damaged or unevenly worn tire at the time of rotation. After tire rotation, adjust the tire pressures and make sure the wheel nuts are correctly tightened.

After driving approximately 600 miles (1,000 km), check the wheel nuts again and retighten any nut that has become loose.

■ Tire replacement

The wheels and tires are important and integral parts of your vehicle's design; they cannot be changed arbitrarily. The tires fitted as standard equipment are optimally matched to the characteristics of the vehicle and were selected to give the best possible combination of running performance, ride comfort, and service life. It is essential for every tire to have a size and construction matching those shown on the tire placard and to have a speed symbol and load index matching those shown on the tire placard.

Using tires of a non-specified size detracts from controllability, ride comfort, braking performance, speedometer accuracy and odometer accuracy. It also creates incorrect body-to-tire clearances and inappropriately changes the vehicle's ground clearance.

All four tires must be the same in terms of manufacturer, brand (tread pattern), construction, and size. You are advised to replace the tires with new ones that are identical to those fitted as standard equipment.

For safe vehicle operation, SUBARU recommends replacing all four tires at the same time.

⚠ WARNING

- When replacing a tire, you must use a tire that is of the same size, circumference, construction, brand (tread pattern), speed symbol and load index as the original tires listed on the tire placard. Using tires of other sizes, circumferences or constructions may result in severe mechanical damage to the drive train of your vehicle and may affect ride, handling, braking, speedometer/odometer calibration, and clearance between the body and tires. It also may be dangerous and lead to loss of vehicle control.
- You must install four tires that are of the same size, circumference, construction, manufacturer, brand (tread pattern), degree of wear, speed symbol and load index. Mixing tires of different types, sizes or degrees of wear can result in damage to the vehicle's power train. Use of different types or sizes of tires can also dangerously reduce controllability and braking performance and can lead to an accident.

- Use only radial tires. Do not use radial tires together with belted bias tires and/or bias-ply tires. Doing so can dangerously reduce controllability, resulting in an accident.

■ Wheel replacement

When replacing wheels due, for example, to damage, make sure the replacement wheels match the specifications of the wheels that are fitted as standard equipment. Replacement wheels are available from SUBARU dealers.

WARNING

Use only those wheels that are specified for your vehicle. Wheels not meeting specifications could interfere with brake caliper operation and may cause the tires to rub against the wheel well housing during turns. The resulting loss of vehicle control could lead to an accident.

Aluminum wheels

Aluminum wheels can be scratched and damaged easily. Handle them carefully to maintain their appearance, performance, and safety.

- When any of the wheels is removed and replaced for tire rotation or to change a flat, always check the tightness of the wheel nuts after driving approximately 600 miles (1,000 km). If any nut is loose, tighten it to the specified torque.
- Never apply oil to the threaded parts, wheel nuts, or tapered surface of the wheel.
- Never let the wheel rub against sharp protrusions or curbs.
- When wheel nuts, balance weights, or the center cap is replaced, be sure to replace them with genuine SUBARU parts designed for aluminum wheels.

Windshield washer fluid

CAUTION

Never use engine coolant as washer fluid because it could cause paint damage.

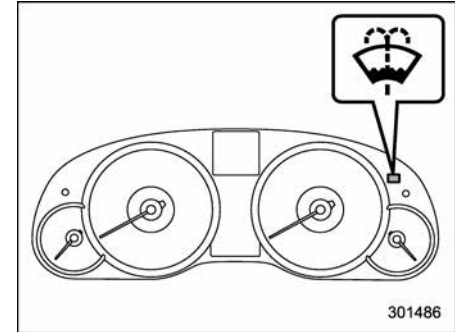

If you spray washer fluid on the windshield but the windshield washer fluid warning light illuminates or the supply of washer fluid runs out, add washer fluid in the tank.

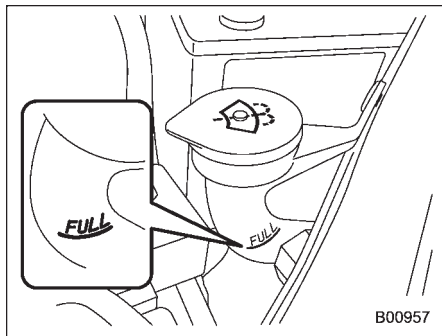
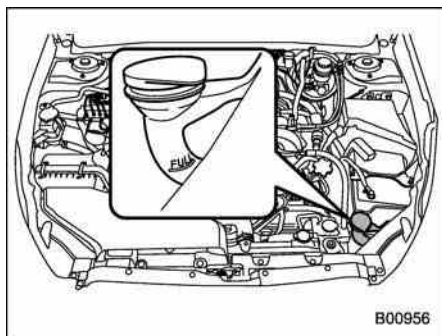

Remove the washer tank filler cap, then add fluid until it reaches the "FULL" mark on the tank.

Use windshield washer fluid. If windshield washer fluid is unavailable use clean water.

In areas where water freezes in winter, use an anti-freeze type windshield washer fluid. SUBARU Windshield Washer Fluid contains 58.5% methyl alcohol and 41.5% surfactant, by volume. Its freezing temperature varies according to how much it is diluted, as indicated in the following table.

Washer Fluid Concentration	Freezing Temperature
30%	10.4°F (-12°C)
50%	-4°F (-20°C)
100%	-49°F (-45°C)

CAUTION

Never use engine coolant as washer fluid because it could cause paint damage.

In order to prevent freezing of washer fluid, check the freezing temperatures in the table above when adjusting the fluid concentration to the outside temperature.

If you fill the reservoir tank with a fluid with a different concentration from the one used previously, purge the old fluid from the piping between the reservoir tank and washer nozzles by operating the washer for a certain period of time. Otherwise, if

the concentration of the fluid remaining in the piping is too low for the outside temperature, it may freeze and block the nozzles.

CAUTION

- Adjust the washer fluid concentration appropriately for the outside temperature. If the concentration is inappropriate, sprayed washer fluid may freeze on the windshield and obstruct your view, and the fluid may freeze in the reservoir tank.
- State or local regulations on volatile organic compounds may restrict the use of methanol, a common windshield washer anti-freeze additive. Washer fluids containing non-methanol anti-freeze agents should be used only if they provide cold weather protection without damaging your vehicle's paint, wiper blades or washer system.

Replacement of wiper blades

Grease, wax, insects, or other materials on the windshield or the wiper blade results in jerky wiper operation and streaking on the glass. If you cannot remove the streaks after operating the windshield washer or if the wiper operation is jerky, clean the outer surface of the windshield (or rear window) and the wiper blades using a sponge or soft cloth with a neutral detergent or mild abrasive cleaner. After cleaning, rinse the windshield and wiper blades with clean water. The windshield is clean if beads do not form when you rinse the windshield with water.



CAUTION

- Do not clean the wiper blades with gasoline or a solvent, such as paint thinner or benzene. This will cause deterioration of the wiper blades.
- When you wish to raise the passenger-side wiper arm, first raise the driver-side wiper arm. Otherwise, the passenger-side wiper assembly and driver-side wiper assembly will touch each other, possibly resulting in scratches.

- Return the passenger-side wiper arm to its original position before returning the driver-side wiper arm to its original position. Otherwise, the passenger-side wiper assembly and driver-side wiper assembly will touch each other, possibly resulting in scratches.
- When returning the raised wipers to the original positions, return the wipers slowly on the windshield by hand. Returning the wipers from the detached positions by the spring operation might change the shape of the wiper arm or scratch the windshield.

If you cannot eliminate the streaking even after following this method, replace the wiper blades using the following procedures.

Windshield wiper blade assembly

1. Raise the wiper arm off the windshield.

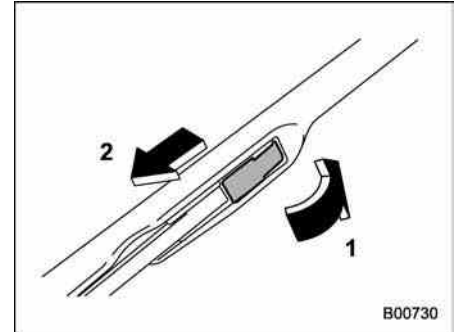

- 1) Open the cover
- 2) Pull down the wiper blade

2. Remove the wiper blade assembly by opening the cover and pulling it down in the direction shown in the illustration.
3. Install the wiper blade assembly to the wiper arm. Make sure that it locks in place.
4. Hold the wiper arm by hand and slowly lower it in position.

Windshield wiper blade rubber

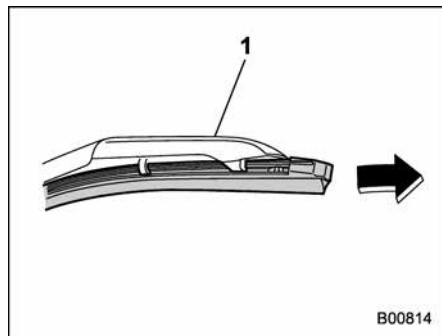

1) Support

1. Grasp the locked end of the blade rubber assembly and pull it firmly until the stoppers on the rubber are free of the support.

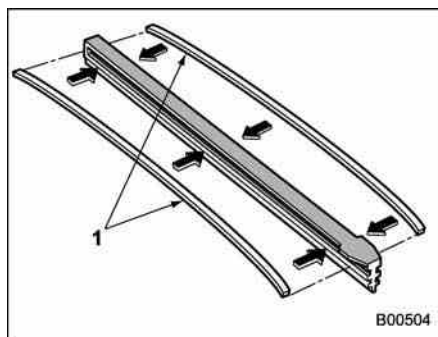

1) Metal spines

2. If the new blade rubber is not provided with two metal spines, remove the metal spines from the old blade rubber and install them in the new blade rubber.

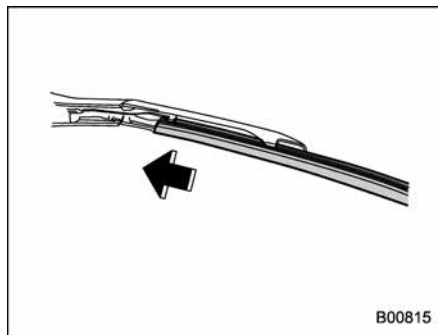

3. Align the claws of the support with the

grooves in the rubber and slide the blade rubber assembly into the support until it locks.

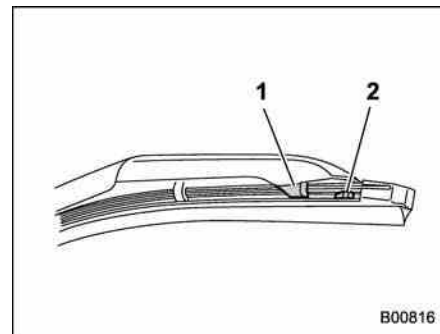

1) Claw
2) Stopper

4. Be sure to position the claws at the end of the support between the stoppers on the rubber as shown. If the rubber is not retained properly, the wiper blade may scratch the windshield.

■ Rear window wiper blade assembly (Outback)

1. Raise the wiper arm off the rear window.

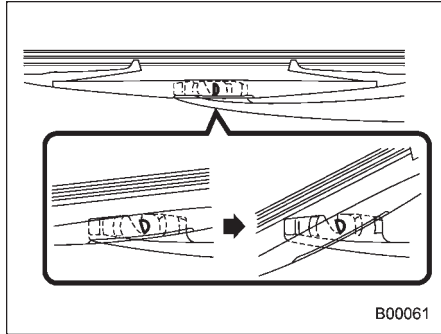

2. Turn the wiper blade assembly counterclockwise.

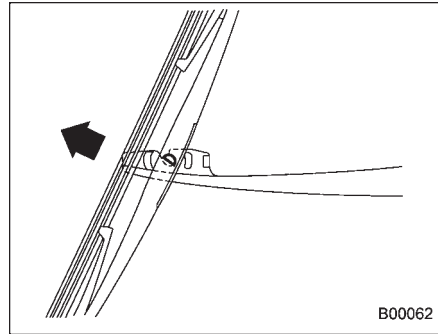

3. Pull the wiper blade assembly toward you to remove it from the wiper arm.

■ Rear window wiper blade rubber (Outback)

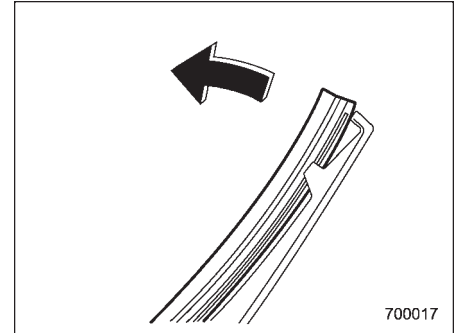

1. Pull out the end of the blade rubber assembly to unlock it from the plastic support.

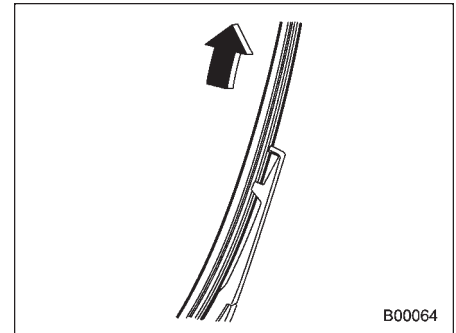

2. Pull the blade rubber assembly out of the plastic support.

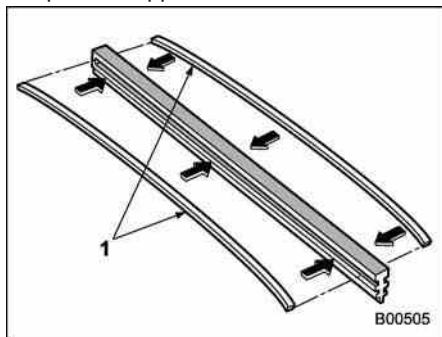

1) Metal spines

3. If the new blade rubber is not provided with two metal spines, remove the metal spines from the old blade rubber and install them in the new blade rubber.

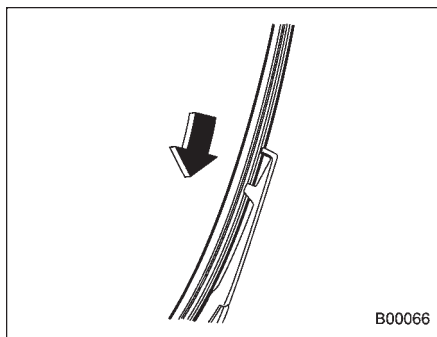

4. Align the claws of the plastic support with the grooves in the blade rubber assembly, then slide the blade rubber assembly into place.

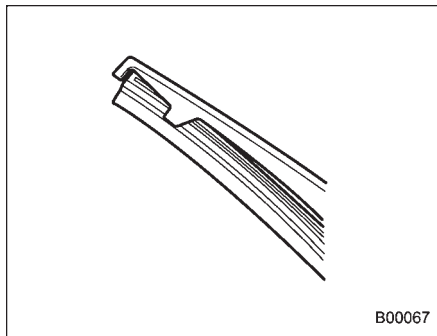

Securely retain both ends of the rubber with the stoppers on the plastic support

ends. If the rubber is not retained properly, the wiper may scratch the rear window glass.

5. Install the wiper blade assembly to the wiper arm. Make sure that it locks in place.

6. Hold the wiper arm by hand and slowly lower it in position.

Battery

WARNING

- Before beginning work on or near any battery, be sure to extinguish all cigarettes, matches, and lighters. Never expose a battery to an open flame or electric sparks. Batteries give off a gas which is highly flammable and explosive.
- For safety, in case an explosion does occur, wear eye protection or shield your eyes when working near any battery. Never lean over a battery.
- Do not let battery fluid contact eyes, skin, fabrics, or paint because battery fluid is a corrosive acid. If battery fluid gets on your skin or in your eyes, immediately flush the area with water thoroughly. Seek medical help immediately if acid has entered the eyes.

If battery fluid is accidentally swallowed, immediately drink a large amount of milk or water, and seek medical attention immediately.

- To lessen the risk of sparks,

remove rings, metal watchbands, and other metal jewelry. Never allow metal tools to contact the positive battery terminal and anything connected to it WHILE you are at the same time in contact with any other metallic portion of the vehicle because a short circuit will result.

- Keep everyone including children away from the battery.
- Charge the battery in a well-ventilated area.
- Battery posts, terminals, and related accessories contain lead and lead compounds, chemicals known to the State of California to cause cancer and reproductive harm. Batteries also contain other chemicals known to the State of California to cause cancer. Wash hands after handling.

CAUTION

Never use more than 10 amperes when charging the battery because it will shorten battery life.

It is unnecessary to periodically check the battery fluid level or periodically refill with

distilled water.

Fuses

CAUTION

Never replace a fuse with one having a higher rating or with material other than a fuse because serious damage or a fire could result.

The fuses are designed to melt during an overload to prevent damage to the wiring harness and electrical equipment. The fuses are located in two fuse boxes.

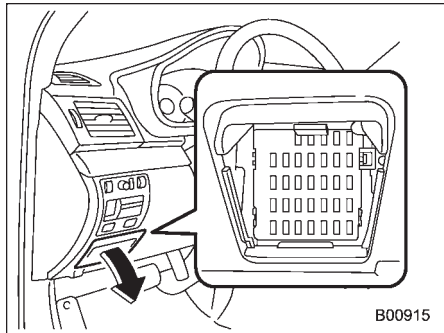

One is located under the instrument panel behind the fuse box cover on the driver's seat side. To remove the cover, pull it out.

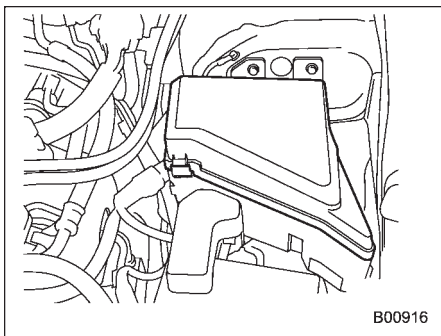

The other one (main fuse box) is housed in the engine compartment.

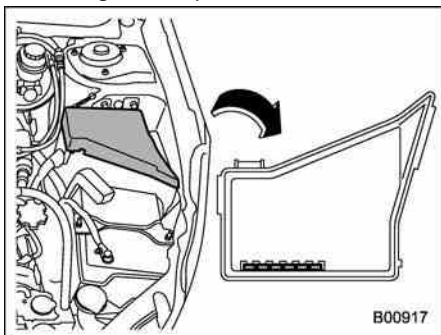

The spare fuses are stored in the main fuse box cover in the engine compartment.

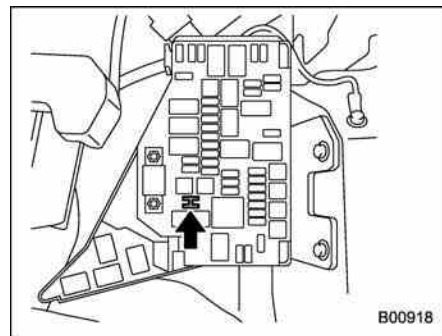

The fuse puller is stored in the main fuse box in the engine compartment.

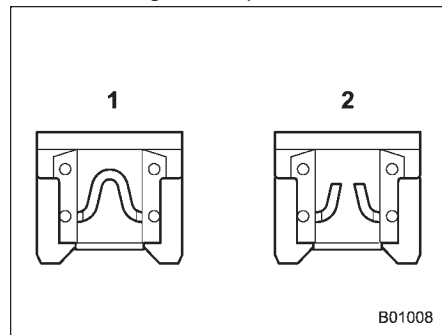

- 1) Good
- 2) Blown

If any lights, accessories or other electrical controls do not operate, inspect the

corresponding fuse. If a fuse has blown, replace it.

1. Turn the ignition switch to the "LOCK" position and turn off all electrical accessories.
2. Remove the cover.
3. Determine which fuse may be blown. Look at the back side of each fuse box cover and refer to "Fuses and circuits" [12-10](#).

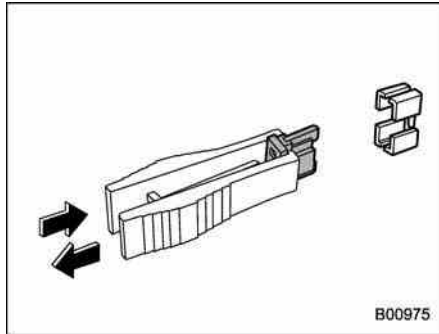

4. Pull out the fuse with the fuse puller.
5. Inspect the fuse. If it has blown, replace it with a spare fuse of the same rating.
6. If the same fuse blows again, this indicates that its system has a problem. Contact your SUBARU dealer for repairs.

Installation of accessories

Always consult your SUBARU dealer before installing fog lights or any other electrical equipment in your vehicle. Such accessories may cause the electronic system to malfunction if they are incorrectly installed or if they are not suited for the vehicle. We recommend that you install only genuine SUBARU accessories on your vehicle.

Replacing bulbs

WARNING

Bulbs may become very hot while illuminated. Before replacing bulbs, turn off the lights and wait until the bulbs cool down. Otherwise, there is the risk of sustaining a burn injury.

CAUTION

Replace any bulb only with a new bulb of the specified wattage. Using a bulb of different wattage could result in a fire. For the specified wattage of each bulb, refer to "Bulb chart" [12-14](#).

■ Headlight

CAUTION

Halogen headlight bulbs become very hot while in use. If you touch the bulb surface with bare hands or greasy gloves, fingerprints or grease on the bulb surface will develop into hot spots, causing the bulb to break. If there are finger-

prints or grease on the bulb surface, wipe them away with a soft cloth moistened with alcohol.

NOTE

- If headlight aiming is required, consult your SUBARU dealer for proper adjustment of the headlight aim.
- It may be difficult to replace the bulbs. We recommend that you have the bulbs replaced by your SUBARU dealer if necessary.

▼ Low beam light bulbs

1. Pull off the fender lining. For details, refer to "Pulling off the fender lining" 11-7.

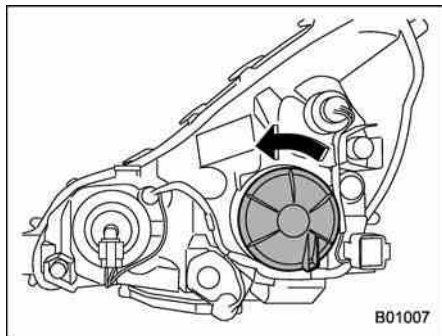

2. Remove the bulb cover, by turning it

counterclockwise.

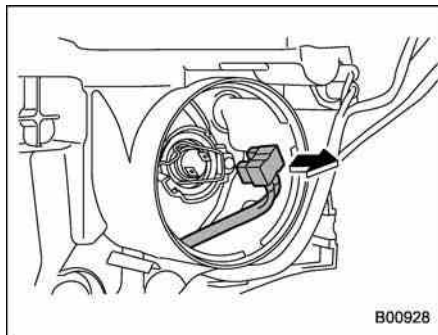

3. Disconnect the electrical connector.

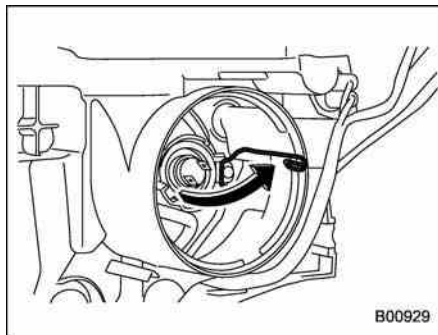

4. Remove the retainer spring.

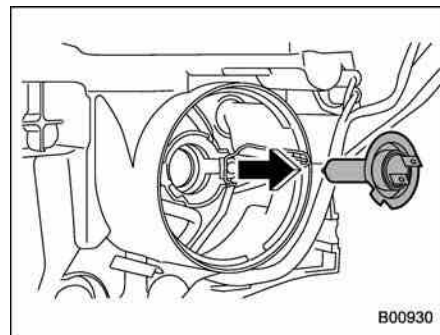

5. Replace the bulb, then set the retainer spring securely.
6. Reconnect the electrical connector.
7. Install the bulb cover.

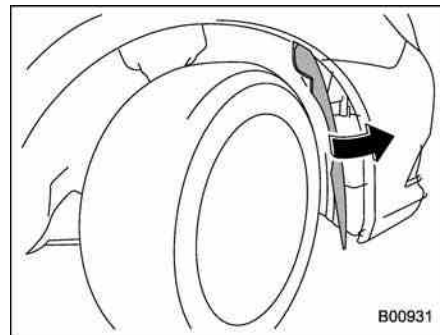

8. After replacing the bulb, reattach the fender lining.

▼ High beam light bulbs

1. Remove the air intake duct (right-hand side). For the method to remove the air intake duct, refer to "Removing air intake duct" 11-7.

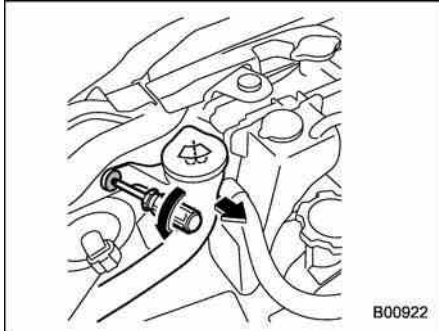

Left-hand side

2. Use a screwdriver to remove the secured clip of the washer tank. To make it easy to access the bulb, move the washer tank to the horizontal direction (left-hand side).

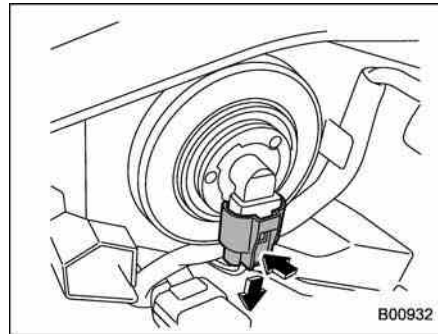

3. Disconnect the electrical connector from the bulb.

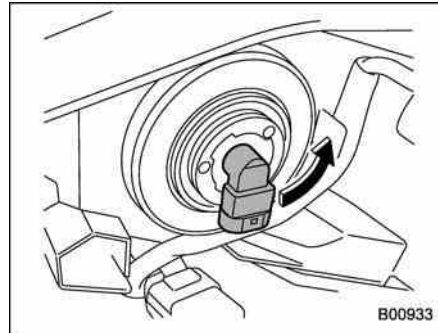

4. Remove the bulb from the headlight assembly by turning it counterclockwise.

5. Replace the bulb with new one. At this time, use care not to touch the bulb

surface.

6. Reconnect the electrical connector.

7. To install the bulb to the headlight assembly, turn it clockwise until it clicks.

8. Install the air intake duct with clips (right-hand side).

9. Set the washer tank to the original place and secure it by clip (left-hand side).

■ Front turn signal light

NOTE

It may be difficult to replace the bulbs. We recommend that you have the bulbs replaced by your SUBARU dealer if necessary.

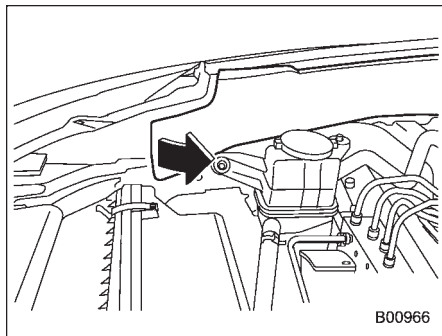

1. Turn over the protective cover of the engine compartment.

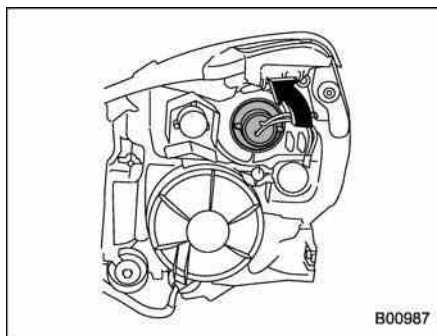

2. Turn the socket counterclockwise and pull it out.
3. Pull out the bulb from the socket and replace the bulb with a new one.

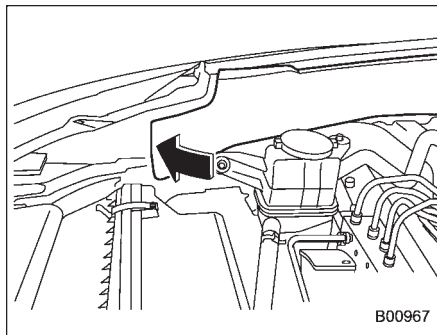

4. After replacing the bulbs, reposition the protective cover of the engine com-

partment.

■ Front position light

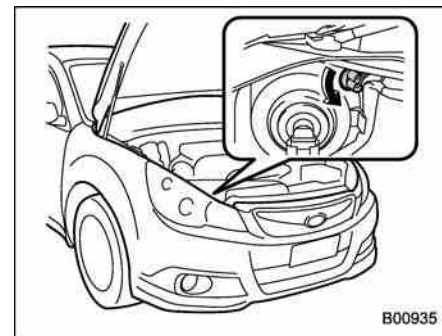

1. Turn the socket counterclockwise and pull it out.
2. Pull out the bulb from the socket and replace the bulb with a new one.

■ Front fog light (if equipped)

NOTE

It may be difficult to replace the bulbs. We recommend that you have the bulbs replaced by your SUBARU dealer if necessary.

1. Pull off the fender lining. Refer to "Pulling off the fender lining" 11-7.

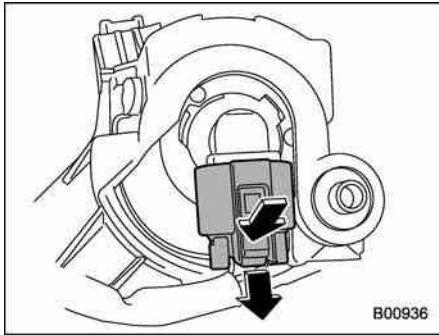

2. Disconnect the electrical connector.

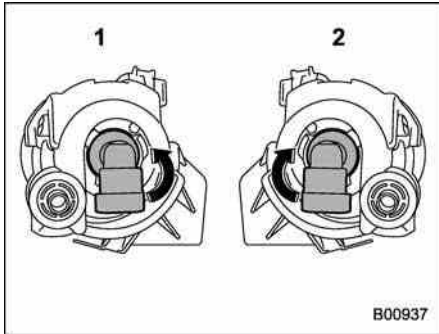

- 1) For left-hand side
- 2) For right-hand side

3. Turn the socket clockwise (right-hand side) or counterclockwise (left-hand side).

4. Pull out the socket.

5. Pull out the bulb from the socket and replace the bulb with a new one.

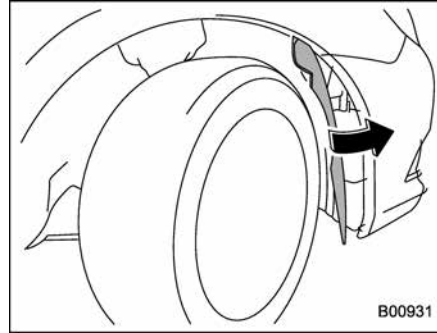

6. After replacing the bulb, reattach the fender lining.

■ Rear combination lights

▼ Legacy

NOTE

It may be difficult to replace the bulbs. We recommend that you have the bulbs replaced by your SUBARU dealer if necessary.

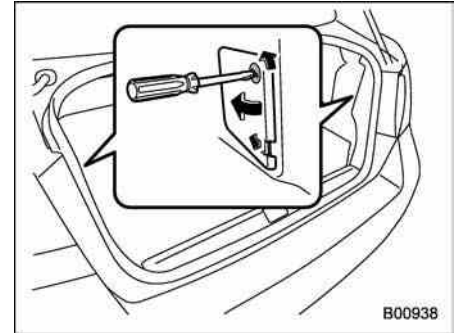

1. Turn the knobs of the cover 90 degrees counterclockwise to remove the cover.

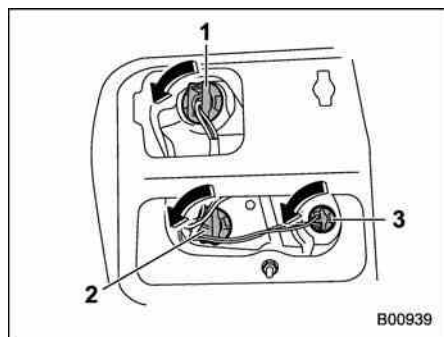

- 1) Brake/tail and rear side marker light
- 2) Rear turn signal light
- 3) Back-up light

2. Remove the bulb holder from the rear combination light assembly by turning it counterclockwise. Use pliers if necessary.
3. Pull the bulb out of the bulb holder and replace it with a new one.
4. Set the bulb holder into the rear combination light assembly and turn it clockwise until it locks.
5. Securely lock the cover against the trunk trim.

▼ Outback

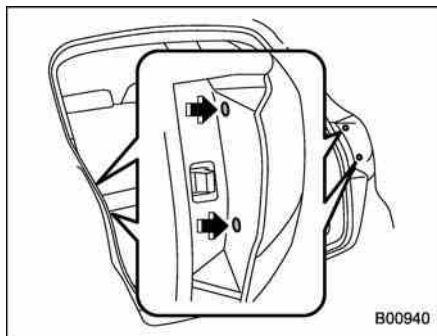

1. Undo the clips. For the method to undo the clips, refer to "Type C clips" ¶ 11-6.
2. Remove the cover.

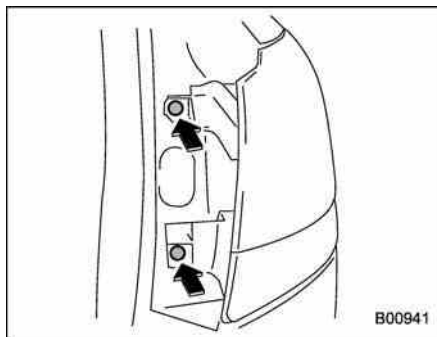

3. Remove the upper and lower screws.

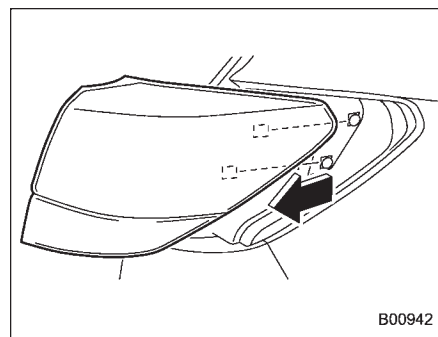

4. Slide the rear combination light assembly straight rearward and remove it from the vehicle.

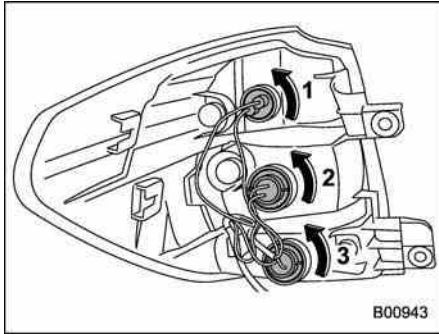

- 1) Tail and rear side marker light
- 2) Brake light
- 3) Rear turn signal light

5. Remove the bulb holder from the rear combination light assembly by turning it counterclockwise.
6. Pull the bulb out of the bulb holder and replace it with a new one.
7. Set the bulb holder into the rear combination light assembly and turn it clockwise until it locks.

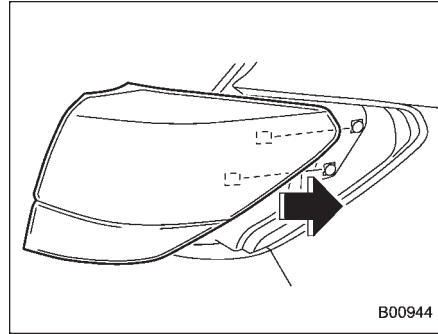

8. Reinstall the rear combination light assembly by sliding the two-pronged part of the combination light assembly securely to each holder of the vehicle side.

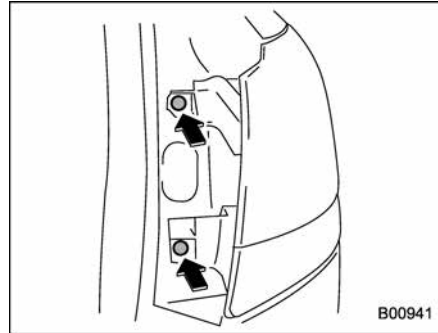

9. Tighten the upper and lower screws.
10. Reinstall the side cover.

■ Tail/Back-up light (Outback)

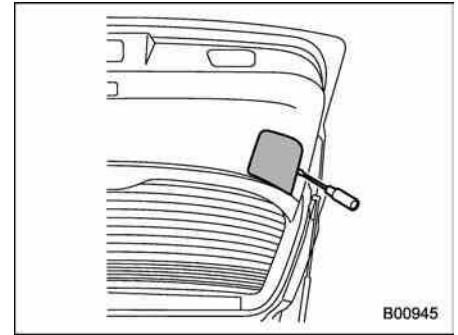

1. Apply a flat-head screwdriver to the light cover as shown in the illustration, and pry the light cover off from the rear gate trim.

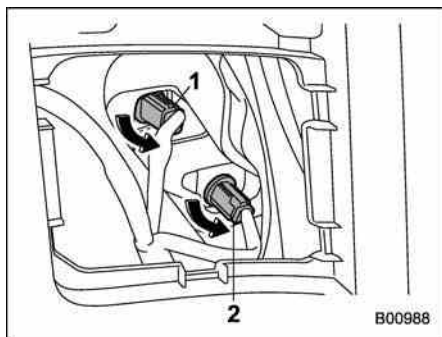

- 1) Back-up light
- 2) Tail light

2. Turn the bulb socket counterclockwise and remove it.

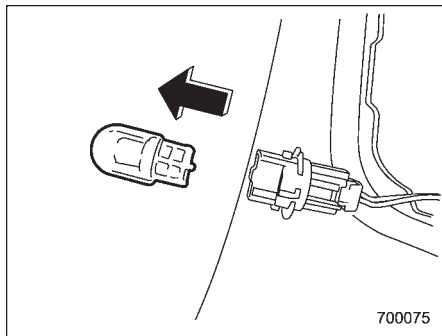

3. Pull the bulb out of the bulb socket and replace it with a new one.

4. Install the bulb socket by turning it clockwise.
5. Install the light cover on the rear gate.

■ License plate light

▼ Legacy

NOTE

It may be difficult to replace the bulbs. We recommend that you have the bulbs replaced by your SUBARU dealer if necessary.

1. Open the trunk.

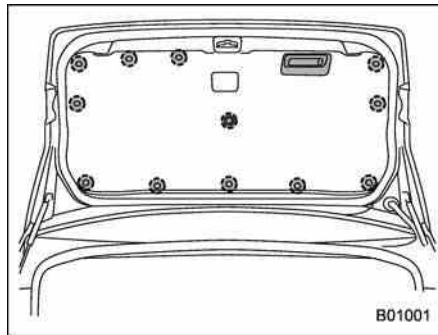

2. Remove the trunk trim lining by removing the 12 clips and the trunk trim handle.

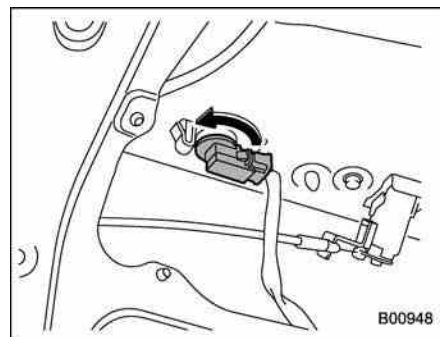

3. Turn the bulb socket counterclockwise and remove it.
4. Pull the bulb out of the bulb socket and replace it with a new one.
5. Install the bulb socket by turning it clockwise.
6. Reinstall the trunk trim lining.

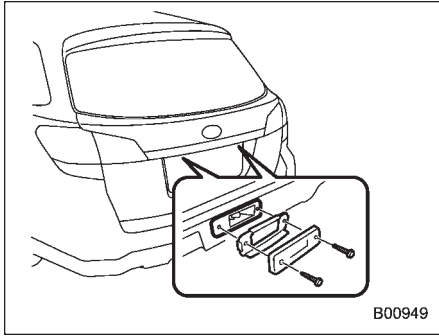
▼ Outback

1. Remove the mounting screws using a Phillips screwdriver.
2. Remove the lens.

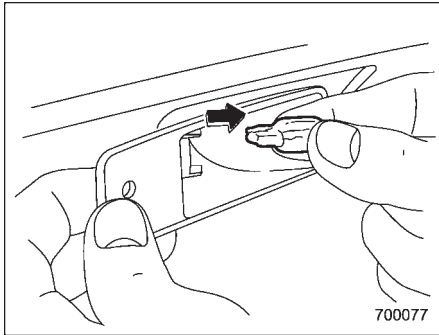

3. Pull the bulb out of the socket.

4. Install a new bulb.
5. Reinstall the lens.
6. Tighten the mounting screws.

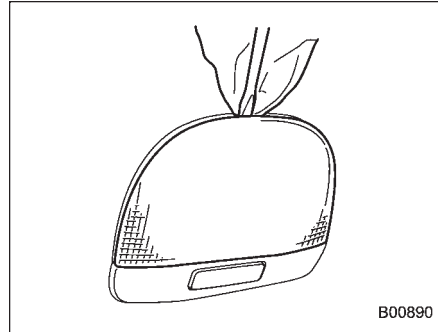
■ Dome light

1. Remove the lens by prying the edge of the lens with a flat-head screwdriver.

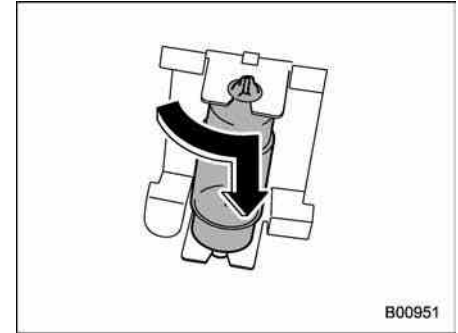

2. Turn the bulb until the flat surfaces at its ends are aligned vertically.
3. Pull the bulb straight downward to remove it.
4. Install a new bulb.
5. Reinstall the lens.

■ Map light

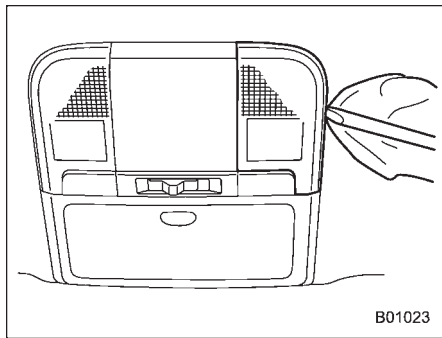

1. Remove the lens by prying the edge of the lens with a flat-head screwdriver.

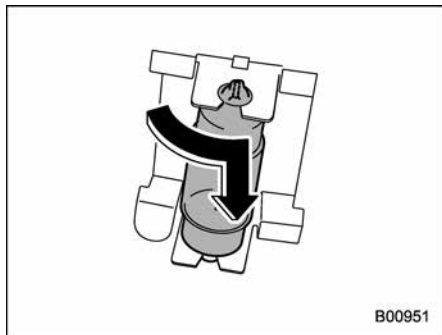

2. Turn the bulb until the flat surfaces at its ends are aligned vertically. Pull the bulb

straight downward to remove it.

3. Install a new bulb.
4. Reinstall the lens.

■ Vanity mirror light

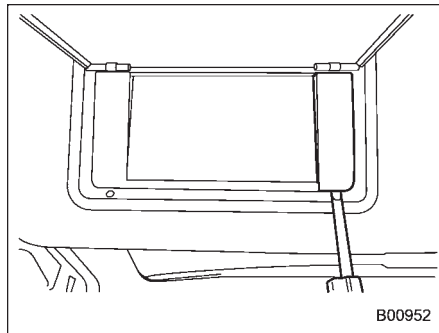

1. Remove the lens by prying the edge of the lens with a flat-head screwdriver.

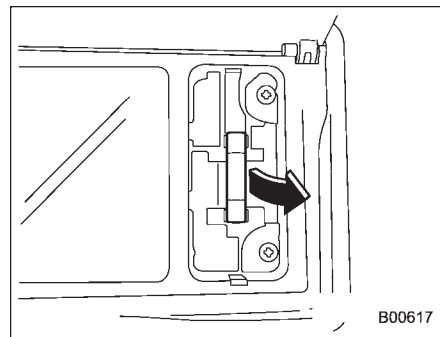

2. Pull the bulb out of the socket.
3. Install a new bulb.
4. Reinstall the lens.

■ Door step light

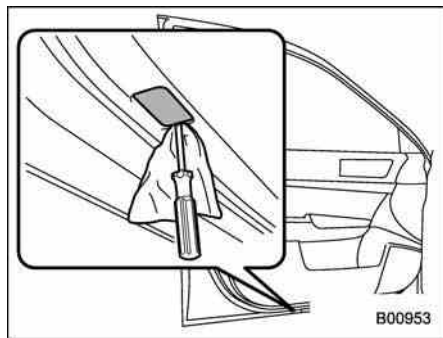

1. Remove the lens by prying the edge of the lens with a flat-head screwdriver.

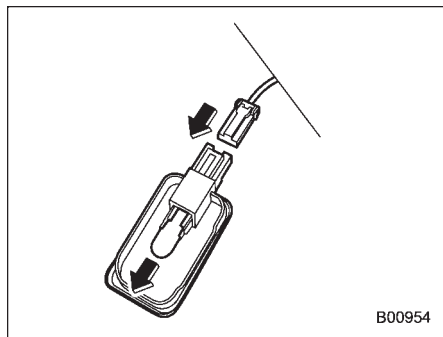

2. Pull the bulb out of the socket.
3. Install a new bulb.

4. Reinstall the lens.

■ Cargo area light (Outback)

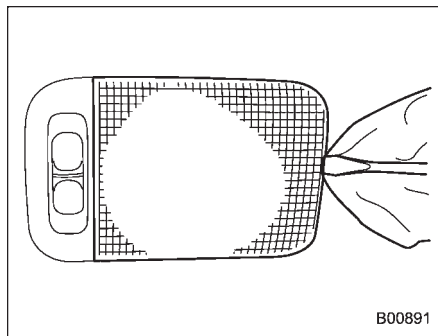

1. Remove the lens by prying the edge of the lens with a flat-head screwdriver.

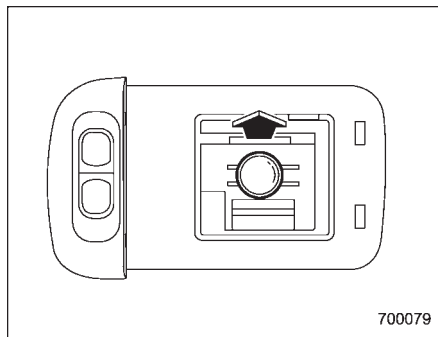

2. Pull the bulb out of the socket.
3. Install a new bulb.
4. Reinstall the lens.

■ Trunk light (Legacy)

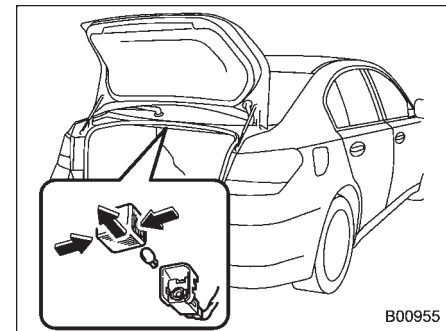

1. Push both sides of the light cover, and then remove the cover by pulling it out.
2. Pull the bulb out of the socket.
3. Install a new bulb.
4. Reinstall the cover.

■ Other bulbs

Other bulbs may be difficult to replace. We recommend that you have the bulbs replaced by your SUBARU dealer if necessary.

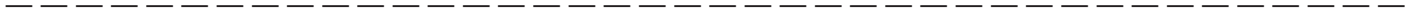
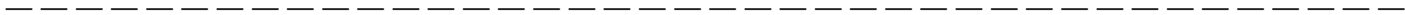
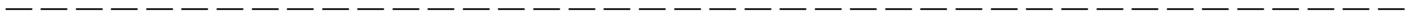

Specifications	12-2	Electrical system	12-9
Dimensions	12-2	Tires	12-9
Engine	12-3	Fuses and circuits	12-10
Fuel	12-3	Fuse panel located in the passenger	
Engine oil	12-4	compartment	12-10
Manual transmission, front differential and rear		Fuse panel located in the engine	
differential gear oil	12-7	compartment	12-12
Fluids	12-8	Bulb chart	12-14
Engine coolant	12-8	Vehicle identification	12-17

Specifications

These specifications are subject to change without notice.

■ Dimensions

in (mm)

Item	Legacy			Outback			
	2.5 L non-turbo	2.5 L turbo	3.6 L	2.5 L non-turbo	3.6 L		
Drive system	AWD						
Transmission type	MT	CVT	MT	AT	MT	CVT	AT
Overall length	186.4 (4,735)			188.2 (4,780)			
Overall width	71.7 (1,820)			71.7 (1,820)			
Overall height	59.3 (1,505)			66.1 (1,680) ^{*2} 65.7 (1,670) ^{*3}			
Wheelbase	108.3 (2,750)			107.9 (2,740)			
Tread	Front	61.6 (1,565)	61.0 (1,550)	61.6 (1,565)	61.0 (1,550)		
	Rear	61.8 (1,570)	61.2 (1,555)	61.8 (1,570)	61.0 (1,550)		
Ground clearance ^{**1}	5.9 (150)			8.7 (220)			

*1: Measured with vehicle empty

*2: Measured when roof rails are used as crossbars

*3: Measured when roof rails are not used as crossbars

AT: Automatic transmission

MT: Manual transmission

CVT: Continuously variable transmission

AWD: All-Wheel Drive

■ Engine

Engine model	EJ253 (2.5 L, SOHC, non-turbo)	EJ255 (2.5 L, DOHC, turbo)	EZ36D (3.6 L, DOHC, non-turbo)
Engine type	Horizontally opposed, liquid cooled 4 cylinder, 4 stroke gasoline engine		Horizontally opposed, liquid cooled 6 cylinder, 4 stroke gasoline engine
Displacement cu-in (cc)	149.9 (2,457)		221.5 (3,630)
Bore × Stroke in (mm)	3.92 × 3.11 (99.5 × 79.0)		3.62 × 3.58 (92.0 × 91.0)
Compression ratio	10.0 : 1	8.4 : 1	10.5 : 1
Firing order	1 – 3 – 2 – 4		1 – 6 – 3 – 2 – 5 – 4

■ Fuel

Vehicle model	Fuel requirement	Fuel tank capacity
Non-turbo models	Unleaded gasoline with 87 AKI (90 RON) or higher	18.5 US gal (70 liters, 15.4 Imp gal)
Turbo models	Premium unleaded gasoline with 93 AKI (98 RON) or higher*1	

*1: If 93 AKI (98 RON) fuel is not available, refer to “Fuel requirements” 7-2.

■ Engine oil

For the checking, adding and replacing procedure or other details, refer to “Engine oil” 11-12.

NOTE

The procedure for changing the engine oil and oil filter should be performed by a properly-trained expert. It is recommended that you have this service performed by your SUBARU dealer.

▼ Approved engine oil

Always use the SUBARU approved engine oil. For further details, please contact your SUBARU dealer.

If the approved engine oil is unavailable, use the alternative engine oil described on the next page.



▼ Alternative engine oil

If the SUBARU approved oil is unavailable, the following alternative oil can be used.

NOTE

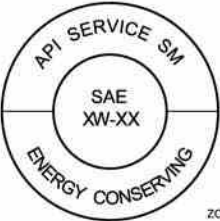

- Each quantity indicated is only a guideline. The necessary quantity for replacement may differ slightly depending on the temperature and other factors.
- In choosing an oil, you want the proper quality and viscosity, as well as one that will enhance fuel economy. Oils of lower viscosity provide better fuel economy. However, in hot weather, oil of higher viscosity is required to properly lubricate the engine. The following table lists the recommended viscosities and applicable temperatures.
- When adding oil, different brands may be used together as long as they are the same API classification and SAE viscosity as those recommended by SUBARU.

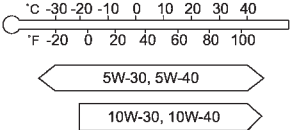
▽ Non-turbo models

Oil grade	SAE viscosity No. and applicable temperature	Engine oil capacity
<div style="display: flex; justify-content: space-around; align-items: center;"> <div style="text-align: center;">  <p>ZOM0297</p> </div> <div style="text-align: center;"> <p>or</p>  <p>ZOM0293</p> </div> </div> <p>API classification SM or SN with the words "ENERGY CONSERVING" or "RESOURCE CONSERVING"</p> <p>ILSAC GF-4 or GF-5, which can be identified with the ILSAC certification mark (Starburst mark)</p>	<p>Your vehicle is designed to use 5W-30 conventional motor oil, however 5W-30 synthetic may be used for optimum engine performance.</p> <p>If you do choose to use synthetic oil, we recommend that you continue using synthetic for the life of your vehicle.</p> <div style="text-align: center;">  <p>ZOM0346</p> </div>	<p>2.5L models</p> <ul style="list-style-type: none"> - Adding the oil from L to F level: 1.1 US qt (1.0 liter, 0.9 Imp qt) - Changing the oil and oil filter: 4.4 US qt (4.2 liters, 3.7 Imp qt) <p>3.6L models</p> <ul style="list-style-type: none"> - Adding the oil from L to F level: 1.1 US qt (1.0 liter, 0.9 Imp qt) - Changing the oil and oil filter: 6.9 US qt (6.5 liters, 5.7 Imp qt)

12-6 Specifications

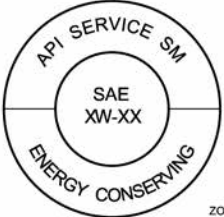
▽ Turbo models

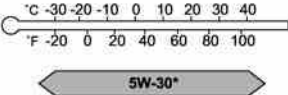
Oil grade	SAE viscosity No. and applicable temperature	Engine oil capacity
<div style="display: flex; justify-content: space-around; align-items: center;"> <div style="text-align: center;">  <p>ZOM0297</p> </div> <div style="text-align: center;"> <p>or</p>  <p>ZOM0293</p> </div> </div> <p>API classification SM or SN with the words "ENERGY CONSERVING" or "RESOURCE CONSERVING"</p> <p>ILSAC GF-4 or GF-5, which can be identified with the ILSAC certification mark (Starburst mark)</p>	<p>5W-30 synthetic oil is required for optimum engine performance and protection. Conventional oil may be used if synthetic oil is unavailable.</p> <p>*: If 5W-30 synthetic oil is not available, 5W-30 or 5W-40 conventional oil may be used if replenishment is needed but should be changed to 5W-30 synthetic oil at the next oil change.</p> <div style="text-align: center;">  </div> <p>ZOM0296</p>	<ul style="list-style-type: none"> - Adding the oil from L to F level: 1.1 US qt (1.0 liter, 0.9 Imp qt) - Changing the oil and oil filter: 4.5 US qt (4.3 liters, 3.8 Imp qt)

Manual transmission, front differential and rear differential gear oil

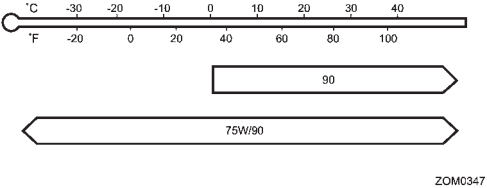
Oil grade	API classification GL-5		
SAE viscosity No. and applicable temperature			
Oil capacity*1	-		Remarks*2
	Manual transmission oil	3.9 US qt (3.7 liters, 3.3 Imp qt)	"Manual transmission oil" ⑩11-21
	Front differential gear oil (AT and CVT models)	1.5 US qt (1.4 liters, 1.2 Imp qt)	"Front differential gear oil (AT and CVT models)" ⑩11-23
	Rear differential gear oil	0.8 US qt (0.8 liters, 0.7 Imp qt)	"Rear differential gear oil" ⑩11-24

*1: The indicated oil quantity is only a guideline. The necessary quantity for replacement may differ slightly depending on the temperature and other factors. After refilling the gearbox with oil, the oil level should be checked.

*2: For more details about maintenance and service, refer to the indicated section.

12-8 Specifications

Fluids

Fluid	Fluid type*1	Fluid capacity*2	Remarks*3
Automatic transmission fluid (5AT models)	<ul style="list-style-type: none"> · SUBARU ATF · IDEMITSU ATF HP 	10.4 US qt (9.8 liters, 8.6 Imp qt)	"Automatic transmission fluid" ☞ 11-21
Continuously variable transmission fluid (CVT models)	Consult your SUBARU dealer.	13.2 US qt (12.5 liters, 11.0 Imp qt)	"Continuously variable transmission fluid" ☞ 11-23
Power steering fluid	<ul style="list-style-type: none"> · SUBARU ATF · IDEMITSU ATF HP · "Dexron III" Type Automatic Transmission Fluid 	0.7 US qt (0.7 liters, 0.6 Imp qt)	<ul style="list-style-type: none"> · "Power steering" ☞ 7-23 · "Power steering fluid" ☞ 11-24
Brake fluid	FMVSS No. 116, fresh DOT 3 or DOT 4 brake fluid	–	"Brake fluid" ☞ 11-25
Clutch fluid (MT models)	FMVSS No. 116, fresh DOT 3 or DOT 4 brake fluid	–	"Clutch fluid (MT models)" ☞ 11-26

*1: Use one of the indicated types of fluid.

*2: The indicated fluid quantity is only a guideline. The necessary quantity for replacement may differ slightly depending on the temperature and other factors.

*3: For more details about maintenance and service, refer to the indicated section.

Engine coolant

Vehicle model	Coolant capacity	Coolant type
2.5 L non-turbo models	MT models	SUBARU Super Coolant
	CVT models	
2.5 L turbo models	6.9 US qt (6.5 liters, 5.7 Imp qt)	
3.6 L models	6.9 US qt (6.5 liters, 5.7 Imp qt)	

The indicated coolant quantity is only a guideline. The necessary quantity for replacement may differ slightly depending on the temperature and other factors. For more details about maintenance and service, refer to "Cooling system" [☞ 11-16](#).

■ Electrical system

Battery type and capacity (5HR)		75D23R (12V-52AH)
Alternator	2.5 L models	12V-110A
	3.6 L models	12V-130A
Spark plugs	2.5 L non-turbo models	SIFR6A11 (NGK)
	2.5 L turbo models	SILFR6B8 (NGK)
	3.6 L models	SILFR6C11 (NGK)

■ Tires

Tire size		P205/60R16 91V	P215/70R16 99S	P225/60R17 98T	P215/50R17 90V	P225/50R17 93V	225/45R18 91W
Wheel size		16 × 6 1/2JJ 16 × 6 1/2J	16 × 6 1/2JJ	17 × 7J	17 × 7 1/2J		18 × 7 1/2J
Pressure	Front	33 psi (230 kPa)	32 psi (220 kPa)		33 psi (230 kPa)		
	Rear	32 psi (220 kPa)	30 psi (210 kPa)		32 psi (220 kPa)		
Temporary spare tire	Size	T135/80R16	T145/80R17		T135/80R16	T135/70R17	
	Pressure	60 psi (420 kPa)					
Wheel nut tightening torque		89 lbf-ft (120 N·m, 12 kgf·m) ^{*1*2}					

*1: This torque is equivalent to applying approximately 88 to 110 lbf (40 to 50 kgf) at the end of the wheel nut wrench. If you have tightened the wheel nuts by yourself, have the tightening torque checked at the nearest automotive service facility as soon as possible.

*2: For the wheel nut tightening procedure, refer to "Changing a flat tire" 9-6.

Fuses and circuits

■ Fuse panel located in the passenger compartment

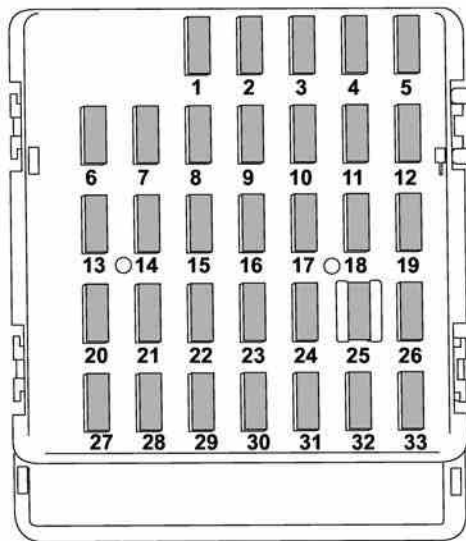

C00123

Fuse panel	Fuse rating	Circuit
1	15A	● Trailer hitch connector
2	20A	● Rear power window (left side)
3	20A	● Power window (driver's side)
4	7.5A	● Navigation system ● Front wiper deicer ● Moonroof
5	7.5A	● Combination meter
6	7.5A	● Remote control rear view mirrors
7	7.5A	● Integrated unit
8	15A	● Stop light
9	15A	● Seat heater relay
10	7.5A	● Power supply (battery)
11	7.5A	● Turn signal unit
12	15A	● Integrated unit ● Automatic transmission unit

Fuse panel	Fuse rating	Circuit
13	20A	● Socket
14	Empty	
15	20A	● Rear power window (right side)
16	Empty	
17	15A	● Front wiper deicer
18	7.5A	● Back-up light
19	7.5A	● Electronic parking brake unit ● Hill Holder system unit
20	10A	● Accessory power outlet
21	7.5A	● Starter relay
22	15A	● Air conditioner
23	Empty	
24	15A	● Audio ● Navigation system
25	15A	● SRS airbag system
26	7.5A	● Main fan
27	30A	● Power window relay

Fuse panel	Fuse rating	Circuit
28	Empty	
29	20A	● Power window (passenger's side)
30	Empty	
31	7.5A	● Automatic air conditioner unit
32	Empty	
33	7.5A	● ABS/Vehicle dynamics control unit ● Power steering

■ Fuse panel located in the engine compartment

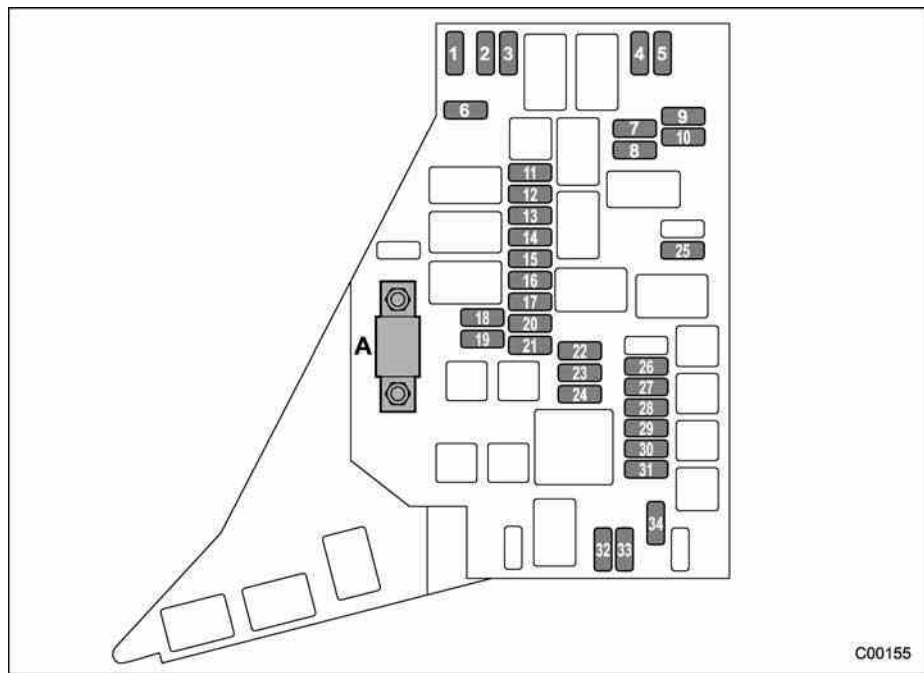

C00155

A) Main fuse

Fuse panel	Fuse rating	Circuit
1	7.5A	● CVT control unit
2	7.5A	● Horn LO
3	7.5A	● Horn HI
4	15A	● Low beam headlight (right side)
5	15A	● Low beam headlight (left side)
6	20A	● Fuel pump
7	10A	● High beam headlight (left side)
8	10A	● High beam headlight (right side)
9	20A	● Continuously variable transmission control unit
10	7.5A	● Alternator
11	20A	● Moonroof
12	7.5A	● Engine control unit

Fuse panel	Fuse rating	Circuit
13	15A	● Engine control unit
14	15A	● Ignition coil
15	15A	● Engine control unit
16	15A	● Engine control unit
17	15A	● Automatic transmission control unit
18	10A	● Illumination
19	10A	● Rear combination light
20	15A	● Turn and hazard warning flasher (body control unit)
21	20A	● Door lock (body control unit)
22	15A	● Rear wiper ● Rear washer
23	10A	● Front washer
24	30A	● Front wiper
25	25A	● Rear window defogger ● Mirror heater ● Front wiper deicer
26	15A	● Blower fan
27	15A	● Blower fan

Fuse panel	Fuse rating	Circuit
28	25A	● Audio unit
29	25A	● Sub fan
30	25A	● Main fan
31	30A	● ABS/Vehicle dynamics control unit
32	10A	● Fog light (right side)
33	10A	● Fog light (left side)
34	10A	● Back-up (body control unit)

Bulb chart

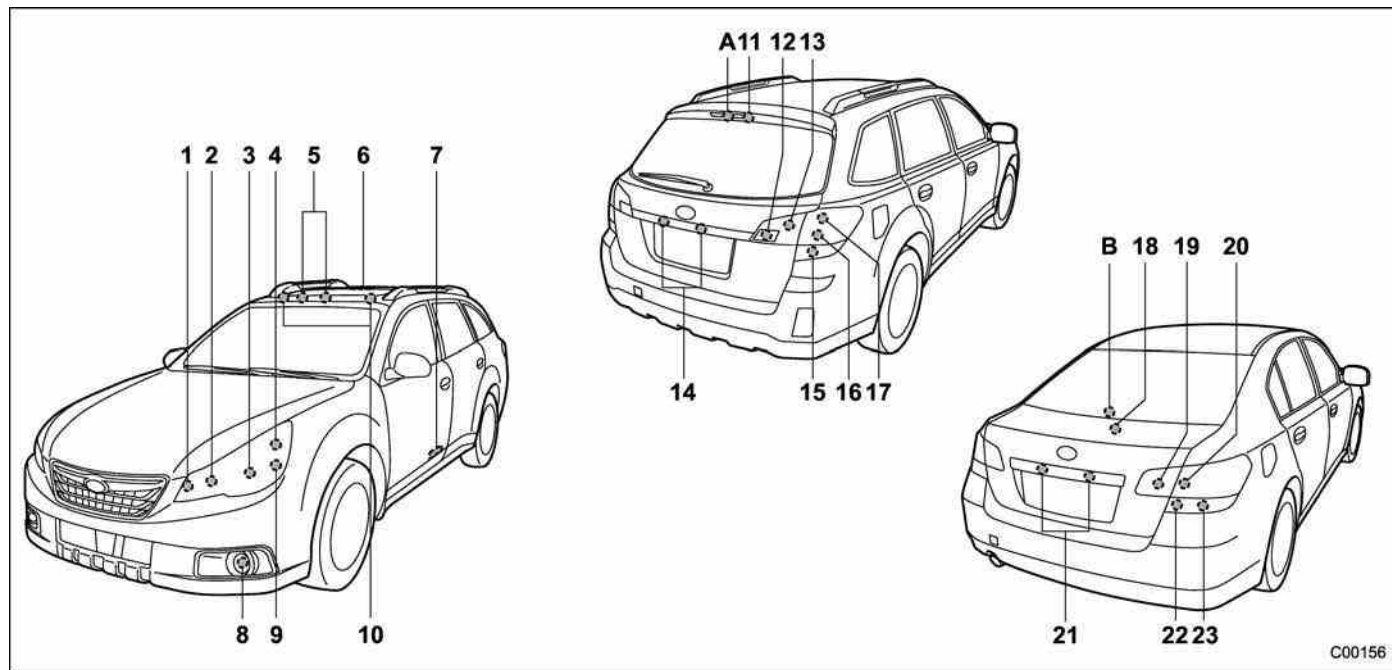

NOTE

Lights A and B are the LED (Light Emitting Diode) type. Consult your SUBARU dealer for replacement.

	Wattage	Bulb No.
1) High beam headlight	12V-60W	HB3 (9005)
2) Front position light	12V-5W	W5W
3) Low beam headlight	12V-55W	H7
4) Front turn signal light	12V-21W	W21W
5) Map light	12V-8W	
6) Dome light	12V-8W	
7) Door step light	12V-5W	W5W
8) Front fog light	12V-55W	H11
9) Front side marker light	12V-5W	W5W
10) Vanity mirror light	14V-1.4W	HTU
11) Cargo area light	12V-13W	
12) Back-up light (Outback)	12V-16W	921
13) Tail light (Outback)	12V-5W	W5W
14) Licence plate light (Outback)	12V-5W	W5W
15) Rear turn signal light (Outback)	12V-21W	WY21W

12-16 Specifications

	Wattage	Bulb No.
16) Brake light (Outback)	12V-21W	W21W
17) Tail and rear side marker light (Outback)	12V-5W	W5W
18) Trunk light (Legacy)	12V-5W	W5W
19) Tail light (Legacy)	12V-5W	W21/5W
20) Brake/Tail and rear side marker light (Legacy)	12V-21/5W	W21/5W
21) License plate light (Legacy)	12V-5W	W5W
22) Back-up light (Legacy)	12V-16W	921
23) Rear turn signal light (Legacy)	12V-21W	WY21W
A) High mount stop light (Outback)	—	—
B) High mount stop light (Legacy)	—	—



WARNING

Bulbs may become very hot while illuminated. Before replacing bulbs, turn off the lights and wait until the bulbs cool down. Otherwise, there is the risk of sustaining a burn injury.



CAUTION

Replace any bulb only with a new bulb of the specified wattage. Using a bulb of different wattage could result in a fire.

Vehicle identification

- 1) Emission control label
- 2) Vehicle identification number
- 3) Certification and bar code label
- 4) Tire inflation pressure label
- 5) Vehicle identification number plate
- 6) Model number label
- 7) Fuel label
- 8) Air conditioner label

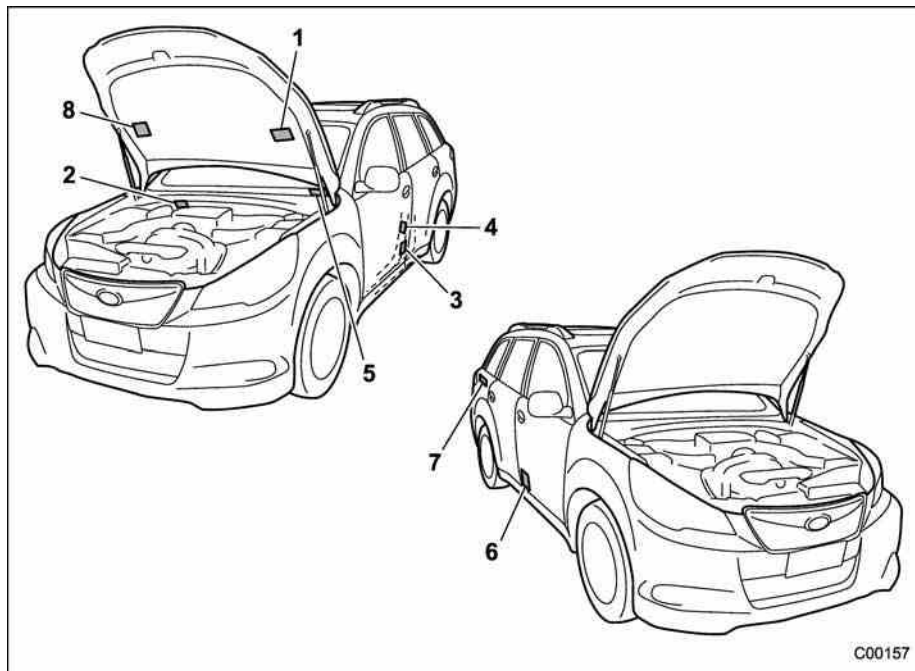

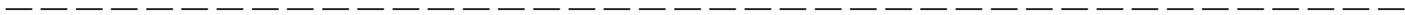
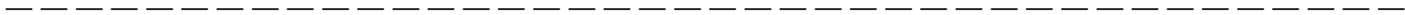
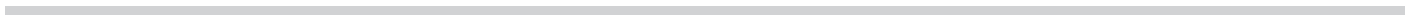

Consumer information and Reporting safety defects

For U.S.A.	13-2	Adverse safety consequences of overloading on handling and stopping and on tires	13-13
Tire information	13-2	Steps for Determining Correct Load Limit	13-13
Tire labeling	13-2	Uniform tire quality grading standards	13-14
Recommended tire inflation pressure	13-4	Treadwear	13-14
Glossary of tire terminology	13-5	Traction AA, A, B, C	13-14
Tire care – maintenance and safety practices	13-9	Temperature A, B, C	13-15
Vehicle load limit – how to determine	13-10	Reporting safety defects (USA)	13-15
Determining compatibility of tire and vehicle load capacities	13-13		

For U.S.A.

The following information has been compiled according to Code of Federal Regulations "Title 49, Part 575".

Tire information

■ Tire labeling

Many markings (e.g. Tire size, Tire Identification Number or TIN) are placed on the sidewall of a tire by tire manufacturers. These marking can provide you with useful information on the tire.

▼ Tire size

Your vehicle comes equipped with P-Metric tire size. It is important to understand the sizing system in selecting the proper tire for your vehicles. Here is a brief review of the tire sizing system with a breakdown of its individual elements.

▽ P Metric

With the P-Metric system, Section Width is measured in millimeters. To convert millimeters into inches, divide by 25.4. The Aspect Ratio (Section Height divided by Section Width) helps provide more dimensional information about the tire size.

Example:

P **205** / **60** **R** **16**
(1) (2) (3) (4) (5)

- (1) P = Certain tire type used on light duty vehicles such as passenger cars
- (2) Section Width in millimeters
- (3) Aspect Ratio (= section height ÷ section width).
- (4) R = Radial Construction
- (5) Rim diameter in inches

▽ Load and Speed Rating Descriptions

The load and speed rating descriptions will appear following the size designation.

They provide two important facts about the tire. First, the number designation is its load index. Second, the letter designation indicates the tire's speed rating.

Example:

P 205 / 60 R 16 91 V
 Size designation (6) (7)

(6) Load Index: A numerical code which specifies the maximum load a tire can carry at the speed indicated by its speed symbol, at maximum inflation pressure.

For example, "91" means 1,356 lbs (615 kg), "90" means 1,323 lbs (600 kg), "89" means 1,279 lbs (580 kg)

WARNING

Load indices apply only to the tire, not to the vehicle. Putting a load rated tire on any vehicle does not mean the vehicle can be loaded up to the tire's rated load.

(7) Speed Rating: An alphabetical system describing a tire's capability to travel at established and predetermined speeds.

For example, "V" means 149 mph (240 km/h)

WARNING

- **Speed ratings apply only to the tire, not to the vehicle. Putting a speed rated tire on any vehicle does not mean the vehicle can be operated at the tire's rated speed.**
- **The speed rating is void if the tires are worn out, damaged, repaired, retreaded, or otherwise altered from their original condition. If tires are repaired, retreaded, or otherwise altered, they may not be suitable for original equipment tire designed loads and speeds.**

▼ Tire Identification Number (TIN)

Tire Identification Number (TIN) is marked on the intended outboard sidewall. The TIN is composed of four groups. Here is a brief review of the TIN with a breakdown of its individual elements.

DOT XX XX XXX XXXX
 (1) (2) (3) (4)

(1) Manufacturer's Identification Mark

(2) Tire Size

(3) Tire Type Code

(4) Date of Manufacture

The first two figures identify the week, starting with "01" to represent the first full week of the calendar year; the second two figures represent the year. For example, 0101 means the 1st week of 2001.

▼ Other markings

The following markings are also placed on the sidewall.

▽ Maximum permissible inflation pressure

The maximum cold inflation pressure to which this tire may be inflated. For example, "350 kPa (51 PSI) MAX. PRESS"

▼ **Maximum load rating**

The load rating at the maximum permissible weight load for this tire. For example, “MAX. LOAD 615 kg (1,356 LBS) @ 350 kPa (51 PSI) MAX. PRESS.”

 WARNING
<p>Maximum load rating applies only to the tire, not to the vehicle. Putting a load rated tire on any vehicle does not mean the vehicle can be loaded up to the tire’s rated load.</p>

▼ **Construction type**

Applicable construction of this tire. For example, “TUBELESS STEEL BELTED RADIAL”

▼ **Construction**

The generic name of each cord material used in the plies (both sidewall and tread area) of this tire. For example, “PLIES: TREAD 2

STEEL + 2 POLYESTER + 1 NYLON SIDEWALL 2 POLYESTER”

▼ **Uniform Tire Quality Grading (UTQG)**

For details, refer to “Uniform tire quality grading standards” 13-14.

■ **Recommended tire inflation pressure**

▼ **Recommended cold tire inflation pressure**

For the recommended cold tire inflation pressure for your vehicle’s tires, refer to “Tires” 12-9.

▼ **Vehicle placard**

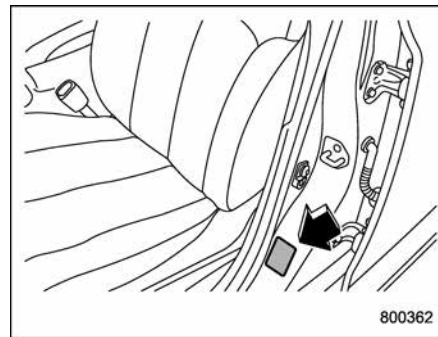

The vehicle placard is affixed to the driver’s side B-pillar.

Example:

 TIRE AND LOADING INFORMATION RENSEIGNEMENTS SUR LES PNEUS ET LE CHARGEMENT				
SEATING CAPACITY NOMBRE DE PLACES		TOTAL X	FRONT X AVANT X	REAR X ARRIERE X
<small>The combined weight of occupants and cargo should never exceed XXXkg or XXXlbs. Le poids total des occupants et du chargement ne doit jamais dépasser XXXkg ou XXXlb.</small>				
TIRE PNEU	SIZE DIMENSIONS	COLD TIRE PRESSURE PRESSION DES PNEUS A FROID	SEE OWNER'S MANUAL FOR ADDITIONAL INFORMATION VOIR LE MANUEL DE L'USAGER POUR PLUS DE RENSEIGNEMENTS	
FRONT AVANT	PXXXXXXRXX	XXXKPA, XXPSI		
REAR ARRIERE	PXXXXXXRXX	XXXKPA, XXPSI		
SPARE DE SECOURS	TXXXXXXDX	XXXKPA, XXPSI		
				D00155

The vehicle placard shows original tire size, recommended cold tire inflation pressure on each tire at maximum loaded vehicle weight, seating capacity and loading information.

▼ **Adverse safety consequences of under-inflation**

Driving at high speeds with excessively low tire pressures can cause the tires to flex severely and to rapidly become hot. A sharp increase in temperature could cause tread separation, and failure of the tire(s). Possible resulting loss of vehicle control could lead to an accident.

▼ **Measuring and adjusting air pressure to achieve proper inflation**

Check and, if necessary, adjust the pressure of each tire (including the spare) at least once a month and before any long journey. Check the tire pressures when the tires are cold. Use a pressure gauge to adjust the tire pressures to the

specific values. Driving even a short distance warms up the tires and increases the tire pressures. Also, the tire pressures are affected by the outside temperature. It is best to check tire pressure outdoors before driving the vehicle. When a tire becomes warm, the air inside it expands, causing the tire pressure to increase. Be careful not to mistakenly release air from a warm tire to reduce its pressure.

■ **Glossary of tire terminology**

● **Accessory weight**

The combined weight (in excess of those standard items which may be replaced) of automatic transmission, power steering, power brakes, power windows, power seats, radio, and heater, to the extent that these items are available as factory-installed equipment (whether installed or not).

● **Bead**

The part of the tire that is made of steel wires, wrapped or reinforced

by ply cords and that is shaped to fit the rim.

● **Bead separation**

A breakdown of the bond between components in the bead.

● **Bias ply tire**

A pneumatic tire in which the ply cords that extend to the beads are laid at alternate angles substantially less than 90 degrees to the centerline of the tread.

● **Carcass**

The tire structure, except tread and sidewall rubber which, when inflated, bears the load.

● **Chunking**

The breaking away of pieces of the tread or sidewall.

● **Cold tire pressure**

The pressure in a tire that has been driven less than 1 mile or has been standing for three hours or more.

● **Cord**

The strands forming the plies in the tire.

● **Cord separation**

The parting of cords from adjacent

rubber compounds.

- **Cracking**

Any parting within the tread, sidewall, or inner liner of the tire extending to cord material.

- **Curb weight**

The weight of a motor vehicle with standard equipment including the maximum capacity of fuel, oil and coolant, and if so equipped, air conditioning and additional weight optional engine.

- **Extra load tire**

A tire designed to operate at higher loads and higher inflation pressure than the corresponding standard tire.

- **Groove**

The space between two adjacent tread ribs.

- **Innerliner**

The layer(s) forming the inside surface of a tubeless tire that contains the inflating medium within the tire.

- **Innerliner separation**

The parting of the innerliner from cord material in the carcass.

- **Intended outboard sidewall**

(1) The sidewall that contains a whitewall, bears white lettering or bears manufacturer, brand, and/or model name molding that is higher or deeper than the same molding on the other sidewall of the tire, or

(2) The outward facing sidewall of an asymmetrical tire that has a particular side that must always face outward when mounting on a vehicle.

- **Light truck (LT) tire**

A tire designated by its manufacturer as primarily intended for use on lightweight trucks or multipurpose passenger vehicles.

- **Load rating**

The maximum load that a tire is rated to carry for a given inflation pressure.

- **Maximum inflation pressure**

The maximum cold inflation pressure to which a tire may be inflated.

- **Maximum load rating**

The load rating for a tire at the

maximum permissible inflation pressure for that tire.

- **Maximum loaded vehicle weight**

The sum of:

- (a) Curb weight
- (b) Accessory weight
- (c) Vehicle capacity weight
- (d) Production options weight

- **Maximum permissible inflation pressure**

The maximum cold inflation pressure to which a tire may be inflated.

- **Measuring rim**

The rim on which a tire is fitted for physical dimension requirements.

- **Normal occupant weight**

150 lbs (68 kg) times the number of occupants specified in the second column of Table 1 that is appended to the end of this section.

- **Occupant distribution**

Distribution of occupants in a vehicle as specified in the third column of Table 1 that is appended to the end of this section.

- **Open splice**

Any parting at any junction of tread,

sidewall, or innerliner that extends to cord material.

- **Outer diameter**

The overall diameter of an inflated new tire.

- **Overall width**

The linear distance between the exteriors of the sidewalls of an inflated tire, including elevations due to labeling, decorations, or protective bands or ribs.

- **Passenger car tire**

A tire intended for use on passenger cars, multipurpose passenger vehicles, and trucks, that have a gross vehicle weight rating (GVWR) of 10,000 lbs (4,535 kg) or less.

- **Ply**

A layer of rubber-coated parallel cords.

- **Ply separation**

A parting of rubber compound between adjacent plies.

- **Pneumatic tire**

A mechanical device made of rubber, chemicals, fabric and steel or other materials, that, when

mounted on an automotive wheel, provides the traction and contains the gas or fluid that sustains the load.

- **Production options weight**

The combined weight of those installed regular production options weighing over 5.1 lbs (2.3 kg) in excess of those standard items which they replace, not previously considered in curb weight or accessory weight, including heavy duty brakes, ride levelers, roof rack, heavy duty battery, and special trim.

- **Radial ply tire**

A pneumatic tire in which the ply cords that extend to the beads are laid at substantially 90 degrees to the centerline of the tread.

- **Recommended inflation pressure**

The cold inflation pressure recommended by a vehicle manufacturer.

- **Reinforced tire**

A tire designed to operate at higher loads and at higher inflation pres-

ures than the corresponding standard tire.

- **Rim**

A metal support for a tire or a tire and tube assembly upon which the tire beads are seated.

- **Rim diameter**

Nominal diameter of the bead seat.

- **Rim size designation**

Rim diameter and width.

- **Rim type designation**

The industry of manufacturer's designation for a rim by style or code.

- **Rim width**

Nominal distance between rim flanges.

- **Section width**

The linear distance between the exteriors of the sidewalls of an inflated tire, excluding elevations due to labeling, decoration, or protective bands.

- **Sidewall**

That portion of a tire between the tread and bead.

- **Sidewall separation**

The parting of the rubber com-

pound from the cord material in the sidewall.

- **Test rim**

The rim on which a tire is fitted for testing, and it may be any rim listed as appropriate for use with that tire.

- **Tread**

That portion of a tire that comes into contact with the road.

- **Tread rib**

A tread section running circumferentially around a tire.

- **Tread separation**

Pulling away of the tread from the tire carcass.

- **Treadwear indicators (TWI)**

The projections within the principal grooves designed to give a visual indication of the degrees of wear of the tread.

- **Vehicle capacity weight**

The rated cargo and luggage load plus 150 lbs (68 kg) times the vehicle's designated seating capacity.

- **Vehicle maximum load on the tire**

Load on an individual tire that is determined by distributing to each axle its share of the maximum loaded vehicle weight and dividing by two.

- **Vehicle normal load on the tire**

Load on an individual tire that is determined by distributing to each axle its share of the curb weight, accessory weight, and normal occupant weight (distributed in accordance with Table 1 that is appended to the end of this section) and dividing by 2.

- **Wheel-holding fixture**

The fixture used to hold the wheel and tire assembly securely during testing.

Table 1 — Occupant loading and distribution for vehicle normal load for various designated seating capacities

Designated seating capacity, number of occupants	Vehicle normal load, number of occupants	Occupant distribution in a normally loaded vehicle
2 through 4	2	2 in front.
5 through 10	3	2 in front, 1 in second seat.
11 through 15	5	2 in front, 1 in second seat, 1 in third seat, 1 in fourth seat.
16 through 22	7	2 in front, 2 in second seat, 2 in third seat, 1 in fourth seat.

■ Tire care – maintenance and safety practices

- Check on a daily basis that the tires are free from serious damage, nails, and stones. At the same time, check the tires for abnormal wear.
- Inspect the tire tread regularly and replace the tires before their tread wear indicators become visible. When a tire's tread wear indicator becomes visible, the tire is worn beyond the acceptable limit and must be replaced immediately. With a tire in this condition, driving at even low speeds in wet weather can cause the vehicle to hydroplane. Possible resulting loss of vehicle control can lead to an accident.

- To maximize the life of each tire and ensure that the tires wear uniformly, it is best to rotate the tires every 7,500 miles (12,000 km). Rotating the tires involves switching the front and rear tires on the right-hand side of the vehicle and similarly switching the front and rear tires on the left-hand side of the vehicle. (Each tire must be kept on its original side of the vehicle.) Replace any damaged or unevenly worn tire at the time of rotation. After tire rotation, adjust the tire pressures and make sure the wheel nuts are correctly tightened. For information about the tightening torque and tightening sequence for the wheel nuts, refer to “Flat tires” ¶9-6.

■ Vehicle load limit – how to determine

The load capacity of your vehicle is determined by weight, not by available cargo space. The load limit of your vehicle is shown on the vehicle placard attached to the

driver’s side B-pillar. Locate the statement “The combined weight of occupants and cargo should never exceed XXX kg or XXX lbs” on your vehicle’s placard.

The vehicle placard also shows seating capacity of your vehicle.

The total load capacity includes the total weight of driver and all passengers and their belongings, any cargo, any optional equipment such as a trailer hitch, roof rack or bike carrier, etc., and the tongue load of a trailer. Therefore cargo capacity can be calculated by the following method.

Cargo capacity = Load limit – (total weight of occupants + total weight of optional equipment + tongue load of a trailer (if applicable))

For towing capacity information and weight limits, refer to “Trailer towing” ¶8-19.

▼ Calculating total and load capacities varying seating configurations

Calculate the available load capacity as shown in the following examples:

Example 1A

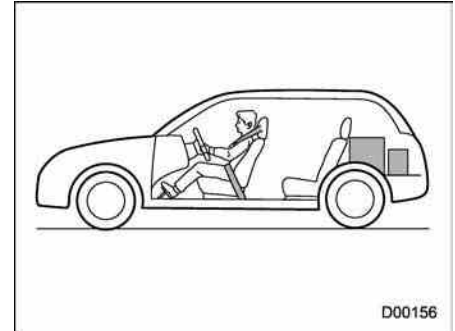

Vehicle capacity weight of the vehicle is 800 lbs (363 kg), which is indicated on the vehicle placard with the statement “The combined weight of occupants and cargo should never exceed 363 kg or 800 lbs”.

For example, if the vehicle has one

occupant weighing 154 lbs (70 kg) plus cargo weighing 551 lbs (250 kg).

1. Calculate the total weight.

Total weight

$$= \frac{154 \text{ lbs (70 kg)}}{\text{(Occupant)}} + \frac{551 \text{ lbs (250 kg)}}{\text{(Cargo)}}$$

$$= \mathbf{705 \text{ lbs (320 kg)}}$$

2. Calculate the available load capacity by subtracting the total weight from the vehicle capacity weight of 800 lbs (363 kg).

Available Load Capacity

$$= \frac{800 \text{ lbs (363 kg)}}{\text{(Vehicle capacity weight)}} - \frac{705 \text{ lbs (320 kg)}}{\text{(Total weight)}}$$

$$= \mathbf{95 \text{ lbs (43 kg)}}$$

3. The result of step 2 shows that a further 95 lbs (43 kg) of cargo can be carried.

Example 1B

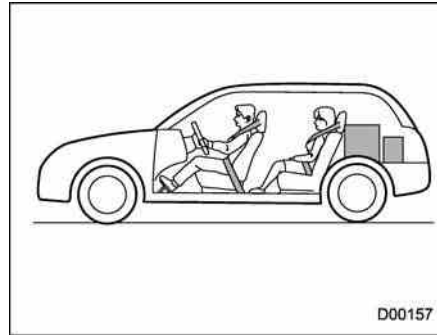

For example, if a person weighing 176 lbs (80 kg) now enters the same vehicle (bringing the number of occupants to two), the calculations are as follows:

1. Calculate the total weight.

Total weight

$$= \frac{154 \text{ lbs (70 kg)}}{\text{(Occupant)}} + \frac{176 \text{ lbs (80 kg)}}{\text{(Occupant)}}$$

$$+ \frac{551 \text{ lbs (250 kg)}}{\text{(Cargo)}}$$

$$= \mathbf{881 \text{ lbs (400 kg)}}$$

2. Calculate the available load capacity.

Available Load Capacity

$$= \frac{800 \text{ lbs (363 kg)}}{\text{(Vehicle capacity weight)}} - \frac{881 \text{ lbs (400 kg)}}{\text{(Total weight)}}$$

$$= \mathbf{-81 \text{ lbs (-37 kg)}}$$

3. The total weight now exceeds the capacity weight by 81 lbs (37 kg), so the cargo weight must be reduced by 81 lbs (37 kg) or more.

Example 2A

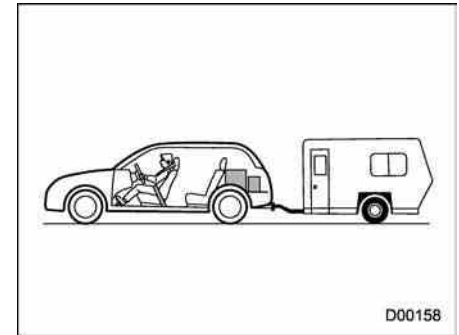

Vehicle capacity weight of the vehicle is 800 lbs (363 kg), which

is indicated on the vehicle placard with the statement “The combined weight of occupants and cargo should never exceed 363 kg or 800 lbs”.

For example, the vehicle has one occupant weighing 165 lbs (75 kg) plus cargo weighing 265 lbs (120 kg). In addition, the vehicle is fitted with a trailer hitch weighing 22 lbs (10 kg), to which is attached a trailer weighing 1,764 lbs (800 kg). 10% of the trailer weight is applied to the trailer tongue (i.e. Tongue load = 176 lbs (80 kg)).

1. Calculate the total weight.

Total weight

$$= \frac{165 \text{ lbs (75 kg)}}{\text{(Occupant)}} + \frac{265 \text{ lbs (120 kg)}}{\text{(Cargo)}}$$

$$+ \frac{22 \text{ lbs (10 kg)}}{\text{(Trailer hitch)}} + \frac{176 \text{ lbs (80 kg)}}{\text{(Tongue load)}}$$

$$= \mathbf{628 \text{ lbs (285 kg)}}$$

2. Calculate the available load capacity.

Available Load Capacity

$$= \frac{800 \text{ lbs (363 kg)}}{\text{(Vehicle capacity weight)}} - \frac{628 \text{ lbs (285 kg)}}{\text{(Total weight)}}$$

$$= \mathbf{172 \text{ lbs (78 kg)}}$$

3. The result of step 2 shows that a further 172 lbs (78 kg) of cargo can be carried.

Example 2B

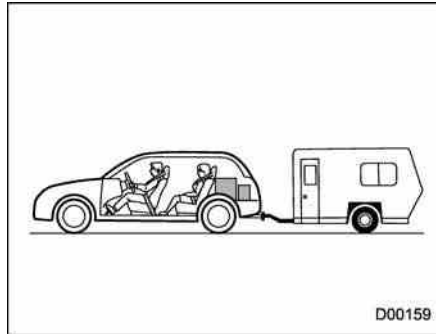

For example, if a person weighing 143 lbs (65 kg) and a child weighing 40 lbs (18 kg) now enter the same

vehicle (bringing the number of occupants to three), and a child restraint system weighing 11 lbs (5 kg) is installed in the vehicle for the child to use, the calculations are as follows:

1. Calculate the total weight.

Total weight

$$= \frac{165 \text{ lbs (75 kg)}}{\text{(Occupant)}} + \frac{143 \text{ lbs (65 kg)}}{\text{(Occupant)}}$$

$$+ \frac{40 \text{ lbs (18 kg)}}{\text{(Occupant)}}$$

$$+ \frac{11 \text{ lbs (5 kg)}}{\text{(Child restraint)}} + \frac{265 \text{ lbs (120 kg)}}{\text{(Cargo)}}$$

$$+ \frac{22 \text{ lbs (10 kg)}}{\text{(Trailer hitch)}} + \frac{176 \text{ lbs (80 kg)}}{\text{(Tongue load)}}$$

$$= \mathbf{822 \text{ lbs (373 kg)}}$$

2. Calculate the available load capacity.

Available Load Capacity

$$= \frac{800 \text{ lbs (363 kg)}}{\text{(Vehicle capacity weight)}} - \frac{822 \text{ lbs (373 kg)}}{\text{(Total weight)}}$$

$$= -22 \text{ lbs (-10 kg)}$$

3. The total weight now exceeds the capacity weight by 22 lbs (10 kg), so the cargo weight must be reduced by 22 lbs (10 kg) or more.

■ Determining compatibility of tire and vehicle load capacities

The sum of four tires' maximum load ratings must exceed the maximum loaded vehicle weight ("GVWR"). In addition, sum of the maximum load ratings of two front tires and of two rear tires must exceed each axle's maximum loaded capacity ("GAWR"). Original equipment tires are designed to fulfill those conditions.

The maximum loaded vehicle weight is referred to Gross Vehicle Weight Rating (GVWR). And each

axle's maximum loaded capacity is referred to Gross Axle Weight Rating (GAWR). The GVWR and each axle's GAWR are shown on the vehicle certification label affixed to the driver's door.

The GVWR and front and rear GAWRs are determined by not only the maximum load rating of tires but also loaded capacities of the vehicle's suspension, axles and other parts of the body.

Therefore, this means that the vehicle cannot necessarily be loaded up to the tire's maximum load rating on the tire sidewall.

■ Adverse safety consequences of overloading on handling and stopping and on tires

Overloading could affect vehicle handling, stopping distance, vehicle and tire as shown in the following. This could lead to an accident and possibly result in severe personal injury.

- Vehicle stability will deteriorate.
- Heavy and/or high-mounted loads could increase the risk of rollover.
- Stopping distance will increase.
- Brakes could overheat and fail.
- Suspension, bearings, axles and other parts of the body could break or experience accelerated wear that will shorten vehicle life.
- Tires could fail.
- Tread separation could occur.
- Tire could separate from its rim.

■ Steps for Determining Correct Load Limit

1. Locate the statement "The combined weight of occupants and cargo should never exceed XXX kg or XXX lbs." on your vehicle's placard.
2. Determine the combined weight of the driver and passengers that will be riding in your vehicle.
3. Subtract the combined weight of the driver and passengers from XXX kg or XXX lbs.

4. The resulting figure equals the available amount of cargo and luggage load capacity. For example, if the “XXX” amount equals 1,400 lbs (635 kg) and there will be five- 150 lbs (68 kg) passengers in your vehicle, the amount of available cargo and luggage load capacity is 650 lbs (1,400 – 750 (5 × 150) = 650 lbs).

5. Determine the combined weight of luggage and cargo being loaded on the vehicle. That weight may not safely exceed the available cargo and luggage load capacity calculated in Step 4.

6. If your vehicle will be towing a trailer, load from your trailer will be transferred to your vehicle. Consult this manual to determine how this reduces the available cargo and luggage load capacity of your vehicle.

Uniform tire quality grading standards

This information indicates the relative performance of passenger car tires in the area of treadwear, traction, and temperature resistance. This is to aid the consumer in making an informed choice in the purchase of tires.

Quality grades can be found where applicable on the tire sidewall between tread shoulder and maximum section width. For example:

Treadwear 200 Traction AA Temperature A

The quality grades apply to new pneumatic tires for use on passenger cars. However, they do not apply to deep tread, winter type snow tires, space-saver or temporary use spare tires, tires with nominal rim diameters of 12 inches or less, or to some limited production tires.

All passenger car tires must con-

form to Federal Safety Requirements in addition to these grades.

■ Treadwear

The treadwear grade is a comparative rating based on the wear rate of the tire when tested under controlled conditions on a specified government test course.

For example, a tire graded 150 would wear one and one-half (1-1/2) times as well on the government course as a tire graded 100. The relative performance of tires depends upon the actual conditions of their use, however, and may depart significantly from the norm due to variations in driving habits, service practices and differences in road characteristics and climate.

■ Traction AA, A, B, C

The traction grades, from highest to lowest, are AA, A, B and C. Those grades represent the tire's ability to stop on wet pavement as measured under controlled conditions on spe-

cified government test surfaces of asphalt and concrete. A tire marked C may have poor traction performance.



WARNING

The traction grade assigned to this tire is based on straight-ahead braking traction tests, and does not include acceleration, cornering, hydroplaning, or peak traction characteristics.

■ Temperature A, B, C

The temperature grades are A (the highest), B, and C, representing the tire's resistance to the generation of heat and its ability to dissipate heat when tested under controlled conditions on a specified indoor laboratory test wheel. Sustained high temperature can cause the material of the tire to degenerate and reduce tire life, and excessive temperature can lead to sudden tire failure. The

grade C corresponds to a level of performance which all passenger car tires must meet under the Federal Motor Vehicle Safety Standards No. 109. Grades B and A represent higher levels of performance on the laboratory test wheel than the minimum required by law.



WARNING

The temperature grade for this tire is established for a tire that is properly inflated and not overloaded. Excessive speed, underinflation, or excessive loading, either separately or in combination, can cause heat buildup and possible tire failure.

Reporting safety defects (USA)

If you believe that your vehicle has a defect which could cause a crash or could cause injury or death, you should immediately inform the National Highway Traffic Safety Administration (NHTSA) in addition to notifying Subaru of America, Inc.

If NHTSA receives similar complaints, it may open an investigation, and if it finds that a safety defect exists in a group of vehicles, it may order a recall and remedy campaign. However, NHTSA cannot become involved in individual problems between you, your dealer, or Subaru of America, Inc. To contact NHTSA, you may call the Vehicle Safety Hotline toll-free at 1-888-327-4236 (TTY: 1-800-424-9153); go to <http://www.safercar.gov>; or write to: Administrator, NHTSA, 1200 New Jersey Avenue, SE, West

Building, Washington, DC 20590.
You can also obtain other information about motor vehicle safety from <http://www.safercar.gov>.

A

ABS (Anti-lock Brake System)	7-24
Warning light	3-16
Accessories	5-3, 11-45
Accessory power outlet	6-10
Air cleaner element	11-18
Air conditioner	
Manual climate control system	4-6
Air filtration system	4-9
Airflow selection	
Automatic climate control system	4-5
Manual climate control system	4-6
Alarm system	2-15
All-Wheel Drive warning light	3-20
Aluminum wheel	11-37
Cleaning	10-3
Antenna system	5-3
Anti-lock Brake System (ABS)	7-24
Arming the system	2-16
Armrest	1-12
Ashtray	6-12
AT OIL TEMP warning light	3-14
Audio	
Antenna system	5-3
Auxiliary input jack	5-30
Bluetooth® audio	5-43
CD player operation	5-23
Control button	5-41
FM/AM radio operation	5-12
iPod® operations	5-33
Satellite radio operations	5-19

Set	5-4
USB storage device operations	5-33
Auto on/off headlights	3-27
Sensor	3-27
Auto-dimming mirror/compass	3-36, 3-43, 3-45
Automatic climate control system	4-5
Automatic rain sensing windshield wipers	3-32
Automatic transmission	7-17
Fluid	11-21, 12-8
Manual mode	7-21
Oil temperature warning light (AT OIL TEMP)	3-14
Select lever	7-18
Shift lock function	7-20
Automatic/Emergency Locking Retractor (A/ELR)	1-13
Auxiliary input jack	5-30

B

Battery	11-43
Drainage prevention function	2-6
Jump starting	9-10
Replacement (remote engine start transmitter)	7-14
Replacement (remote keyless entry system)	2-10
Bluetooth® audio	5-43
Booster seat	1-29
Bottle holder	6-9
Brake	
Assist	7-24
Booster	7-23, 11-27
Fluid	11-25, 12-8
Pad and lining	11-30
Parking	7-31

- Pedal 11-28
- System 7-23
- Brake pedal
 - Free play 11-28
 - Reserve distance 11-28
- Brake system 7-23
- Warning light 3-17
- Braking 7-23
- Tips 7-23
- Breaking-in of new brake pads and linings 11-30
- Bulb
 - Chart 12-14
 - Replacing 11-45
- C**
- Cargo area
 - Cover 6-15
 - Light 6-3
 - Tie-down hooks 6-17
- Catalytic converter 8-3
- Center
 - Console 6-6
- Changing
 - Coolant 11-17
 - Flat tire 9-6
 - Oil and oil filter 11-14
- Charge warning light 3-14
- CHECK ENGINE warning light/Malfunction indicator light 3-12
- Checking
 - Brake pedal free play 11-28
 - Brake pedal reserve distance 11-28
 - Clutch function 11-29
 - Clutch pedal free play 11-29
 - Coolant level 11-17
 - Fluid level (automatic transmission fluid) 11-21
 - Fluid level (brake fluid) 11-25
 - Fluid level (clutch fluid) 11-26
 - Fluid level (power steering fluid) 11-24
 - Fluid level (washer fluid) 11-37
 - Oil level (engine oil) 11-12
 - Oil level (front differential gear oil) 11-23
- Child restraint systems 1-23
- Installation of a booster seat 1-29
- Installation with A/ELR seatbelt 1-26
- Lower and tether anchorages 1-30
- Top tether anchorages 1-33
- Child safety 5
- Locks 2-19
- Chime
 - Key 3-4
 - Light 3-27
 - Seatbelt 3-9
- Cleaning
 - Aluminum wheels 10-3
 - Interior 10-5
 - Ventilation grille 4-8
- Climate control system
 - Automatic 4-5
 - Manual 4-6
- Clock 3-23

Clutch	
Fluid.....	11-26, 12-8
Pedal	11-29
Coat hook.....	6-13
Compass.....	3-36, 3-43, 3-45
Continuously variable transmission.....	7-17
Fluid.....	11-23, 12-8
Manual mode	7-21
Oil temperature warning light (AT OIL TEMP)	3-14
Select lever	7-18
Shift lock function.....	7-20
Coolant.....	11-17, 12-8
Temperature high warning light	3-13
Temperature low indicator light.....	3-13
Cooling system.....	11-16
Corrosion protection	10-4
Crossbars	8-14
Cruise control	7-35
Indicator light.....	3-23
Set indicator light	3-23
Cup holder	6-8
Front passenger's	6-9
Rear passenger's.....	6-9

D

Daytime running light system.....	3-28
Defogger.....	3-34
Deicer	3-34
Differential gear oil	
Front	11-23, 12-7
Rear.....	11-24, 12-7

Dimensions.....	12-2
Disarming the alarm system.....	2-17
Disc brake pad wear warning indicators	7-24
Dome light.....	6-2, 11-53
Door	
Locks.....	2-4
Open indicator light.....	3-19
Step light.....	11-55
Double trip meter.....	3-6
Drive belts	11-21
Driving	
All-Wheel Drive warning light	3-20
AWD vehicles	8-5
Car phone/cell phone.....	7
Drinking.....	6
Drugs.....	7
Foreign countries.....	8-4
Off road.....	8-6
Pets.....	8
Snowy and icy roads	8-10
Tips	7-17, 7-22, 8-2, 8-5
Tired or sleepy	7
Winter.....	8-8

E

ECO gauge	3-8
Electrical system	12-9
Electronic Brake Force Distribution (EBD) system... ..	3-18, 7-25
Electronic parking brake	7-31
Automatic release function by accelerator pedal	7-32
Hill Holder	7-32

Warning	3-18, 7-34
Emergency Locking Retractor (ELR).....	1-13
Engine	
Compartment overview	11-9
Coolant.....	11-17, 12-8
Exhaust gas (carbon monoxide).....	6, 8-2
Hood	11-7
Low oil level warning light	3-14
Oil.....	11-12, 12-4
Overheating	9-13
Starting.....	7-8
Stopping	7-10
Exterior care.....	10-2

F

Flat tires	9-6
Floor mat	6-14
Fluid level	
Automatic transmission.....	11-21
Brake	11-25
Clutch.....	11-26
Power steering	11-24
Fog light	
Bulb	11-48
Indicator light.....	3-23
Switch	3-30
Folding mirror switch	3-51
Front	
Differential gear oil	11-23, 12-7
Fog light	3-30, 11-48
Fog light indicator light.....	3-23

Position light.....	11-48
Seatbelt pretensioners	1-21
Turn signal light.....	11-48
Front fog light.....	11-48
Front seats	1-2
Forward and backward adjustment	1-3
Head restraint adjustment.....	1-6
Power seat	1-4
Reclining	1-3
Seat height adjustment (driver's seat)	1-4
Fuel.....	7-2
Economy hints	8-2
Filler lid and cap.....	7-3
Gauge.....	3-7
Requirements	7-2, 12-3
Fuses	11-44
Fuses and circuits	12-10

G

GAWR (Gross Axle Weight Rating).....	8-14
Glove box.....	6-6
GVWR (Gross Vehicle Weight Rating).....	8-14

H

Hands-free system.....	5-49
Hazard warning flasher	3-5, 9-2
Head restraint adjustment	
Front seat.....	1-6
Rear seat	1-10
Headlight.....	3-27, 11-45
Bulb wattage.....	12-14

Control switch.....	3-27
Flasher	3-28
Indicator light.....	3-23
High beam indicator light	3-22
High/low beam change (dimmer).....	3-28
Hill Holder.....	7-32
Indicator light.....	3-19
Switch	7-32
HomeLink®	3-36, 3-45
Hook	
Coat.....	6-13
Convenient tie-down.....	6-17
Shopping bag	6-13
Towing and tie-down.....	9-14
Horn.....	3-52
Hose and connections	11-17
I	
Ignition switch.....	3-3
Light.....	3-4
Illumination brightness control.....	3-29
Immobilizer.....	2-3
Indicator light (security indicator light)	3-21
Indicator light	
Coolant temperature low	3-13
Cruise control	3-23
Cruise control set.....	3-23
Door open.....	3-19
Front fog light.....	3-23
Headlight	3-23
High beam	3-22

Hill Holder	3-19
Immobilizer	3-21
Security.....	3-21
Select lever/Gear position.....	3-22
Turn signal	3-22
Vehicle Dynamics Control OFF.....	3-21
Vehicle Dynamics Control operation.....	3-21
Inside mirror	3-35, 3-36, 3-43, 3-45
Interior lights	6-2
Internal trunk lid release handle.....	2-24

i

iPod® operations	5-33
------------------------	------

J

Jack-up point	9-6
Jump starting	9-10

K

Key.....	2-2
Number.....	2-2
Reminder chime	3-4
Replacement.....	2-4
Keyless entry system.....	2-7

L

Leather seat materials.....	10-5
License plate light.....	11-52
Light	
Back-up (Legacy)	11-49

Brake (Outback).....	11-50
Brake (Station wagon)	11-50
Brake/Tail (Sedan).....	11-49
Brake/Tail and rear side marker (Legacy).....	11-49
Cargo area.....	6-3, 11-55
Control switch.....	3-27
Dome	6-2, 11-53
Door step.....	11-55
Front fog.....	3-30, 11-48
Front position	11-48
Ignition switch.....	3-4
License plate.....	11-52
Map	6-2, 11-54
Rear combination.....	11-49
Rear turn signal (Sedan).....	11-49
Rear turn signal (Station wagon).....	11-50
Tail and rear side marker (Outback).....	11-50
Tail light (Station wagon).....	11-50
Tail/Back-up (Outback).....	11-51
Trunk.....	11-55
Turn signal.....	3-29, 11-48, 11-49
Vanity mirror.....	6-5, 11-54
Loading your vehicle	8-12
Low fuel warning light.....	3-19
Low tire pressure warning light	3-15
Lower and tether anchorage.....	1-30
M	
Maintenance	
Precautions	11-3
Schedule	11-3

Seatbelt.....	1-20
Tips	11-5
Tools.....	9-3
Malfunction indicator light (check engine warning light)....	3-12
Manual	
Climate control system	4-6
Mode	7-21
Seat.....	1-3
Transmission	7-15
Transmission oil	11-21, 12-7
Map light	6-2, 11-54
Maximum load limits	8-20
Meters and gauges.....	3-5
Mirror defogger	3-34
Mirrors	3-35
Moonroof.....	2-27, 9-20
Multi function display.....	3-24
N	
New vehicle break-in driving	8-2
O	
Odometer	3-6
Off road driving	8-6
Oil filter	11-14
Oil level	
Engine	11-12
Front differential gear	11-23
Manual transmission	11-21
Rear differential gear	11-24
Warning light.....	3-14

Oil pressure warning light.....	3-14
Outside	
Mirror defogger.....	3-34
Mirrors.....	3-50
Overhead console.....	6-8
Overheating engine.....	9-13

P

Parking.....	7-30
Brake.....	7-31
Tips.....	7-34
Periodic inspections.....	8-4
Petrol fuel.....	7-2
Pocket.....	6-8
Power	
Door locking switch.....	2-6
Outside mirrors.....	3-51, 3-51
Seat.....	1-4
Steering.....	7-23
Steering fluid.....	11-24, 12-8
Windows.....	2-20
Precautions against vehicle modification.....	1-22, 1-64
Preparing to drive.....	7-7
Printed antenna.....	5-3

R

Rear	
Combination lights.....	11-49
Differential gear oil.....	11-24, 12-7
Gate.....	2-26, 9-20
Turn signal light.....	11-49

Rear seat.....	1-7
Armrest.....	1-12
Folding down.....	1-9
Head restraint adjustment.....	1-10
Reclining.....	1-8
Rear view camera.....	6-19
Rear window	
Defogger.....	3-34
Wiper and washer switch.....	3-33
Wiper blades.....	11-41
Recommended	
Automatic transmission fluid.....	12-8
Brake fluid.....	12-8
Clutch fluid.....	12-8
Continuously variable transmission fluid.....	12-8
Engine oil.....	12-4
Front differential gear oil.....	12-7
Manual transmission oil.....	12-7
Power steering fluid.....	12-8
Rear differential gear oil.....	12-7
Spark plugs.....	12-9
Refueling.....	7-3
Remote engine start system.....	7-10
Remote keyless entry system.....	2-7
Replacement	
Brake pad and lining.....	11-29
Wiper blades.....	11-39
Replacing	
Air cleaner element.....	11-18
Battery (remote engine start transmitter).....	7-14
Battery (remote keyless entry system).....	2-10

- Lost transmitters (remote keyless entry system)..... 2-12
- Replacing bulbs 11-45
 - Back-up light (Legacy)..... 11-49
 - Brake light (Outback)..... 11-50
 - Brake light (Station wagon) 11-50
 - Brake/Tail and rear side marker light (Legacy) 11-49
 - Brake/Tail light (Sedan)..... 11-49
 - Cargo area light..... 11-55
 - Dome light 11-53
 - Door step light..... 11-55
 - Front fog light..... 11-48
 - Front position light..... 11-48
 - Front turn signal light..... 11-48
 - Headlight 11-45
 - License plate light 11-52
 - Map light..... 11-54
 - Rear combination light..... 11-49
 - Rear turn signal light (Sedan)..... 11-49
 - Rear turn signal light (Station wagon) 11-50
 - Tail and rear side marker light (Outback)..... 11-50
 - Tail light (Station wagon)..... 11-50
 - Tail/Back-up light (Outback)..... 11-51
 - Trunk light..... 11-55
 - Vanity mirror light 11-54
- Rocking the vehicle..... 8-12
- Roof rails with integrated cross bars..... 8-14

- S**
- Safety
 - Precautions when driving 4
 - Symbol 2

- Warnings 2
- Seat
 - Fabric 10-5
 - Front..... 1-2
 - Heater..... 1-6
 - Height adjustment..... 1-4
 - Power 1-4
 - Rear 1-7
- Seatbelt..... 4, 1-12
 - Fastening 1-14
 - Maintenance 1-20
 - Pretensioners..... 1-21
 - Safety tips 1-12
 - Warning light and chime 3-9
- Security
 - Alarm system..... 2-15
 - ID plate 2-3
 - Immobilizer 2-3
 - Indicator light 3-21
 - Shock sensors 2-19
- Select lever 7-18
 - Position indicator 3-22
 - Shift lock function 7-20
- Shock sensors 2-19
- Shopping bag hook..... 6-13
- Snow tires 8-11, 11-30
- Snowy and icy roads 8-10
- Sounding a panic alarm 2-10
- Spark plugs 11-20, 12-9
- Specifications..... 12-2
- Speedometer 3-6

- SRS
Frontal airbag 1-45
SRS airbag (Supplemental Restraint System airbag) ... 4, 1-36
SRS airbag system
Monitors..... 1-62
Servicing..... 1-63
Warning light 3-11
Starting the engine..... 7-8
State emission testing (U.S. only) 7-6
Steering wheel
Power..... 7-23
Tilt/telescopic..... 3-52
Stopping the engine 7-10
Storage compartment 6-5
Sun shade 2-29
Sun visors..... 6-4
Supplemental Restraint System airbag (SRS)..... 1-36
Synthetic leather upholstery 10-5
- T**
Tachometer 3-7
Temperature warning light
AT OIL TEMP 3-14
Coolant..... 3-13
Temporary spare tire 9-2
Tether (child restraint system)..... 1-30, 1-33
Tie-down hooks 9-14
Tire 11-30, 12-9
Chains..... 8-12
Inspection 11-32
Pressures and wear 11-32
Replacement..... 11-36
Rotation 11-35
Size and pressure 12-9
Types..... 11-30
Tire pressure monitoring system (TPMS)..... 7-29, 9-9, 11-30
Warning light..... 3-15
Tires and wheels 11-30
Tools..... 9-3
Top tether anchorages 1-30, 1-33
Towing 9-13
All wheels on the ground 9-16
Flat-bed truck..... 9-16
Hooks 9-14
Weight 8-20
Trailer
Connecting 8-18
Hitch..... 8-17, 8-23
Towing 8-19
Towing tips 8-25
Trip meter..... 3-6
Trunk lid..... 2-23, 9-19
Release handle 2-24
Trunk light 11-55
Turn signal
Indicator lights..... 3-22
Lever 3-29
- U**
Under-floor storage compartment..... 6-18
USB storage device operations 5-33

- V**
- Valet mode..... 2-18
 - Vanity mirror..... 6-5, 11-54
 - Light..... 11-54
 - Vehicle
 - Capacity weight..... 8-13
 - Identification..... 12-17
 - Symbols..... 3
 - Vehicle Dynamics Control
 - OFF indicator light..... 3-21
 - OFF switch..... 7-28
 - Operation indicator light..... 3-20
 - System..... 7-26
 - Warning light..... 3-20
- W**
- Warning and indicator lights..... 3-9
 - Warning chimes
 - Seatbelt..... 3-9
 - Warning light
 - ABS..... 3-16
 - All-Wheel Drive..... 3-20
 - AT OIL TEMP..... 3-14
 - Brake system..... 3-17
 - Charge..... 3-14
 - CHECK ENGINE..... 3-12
 - Coolant temperature high..... 3-13
 - Engine low oil level..... 3-14
 - Low fuel..... 3-19
 - Low tire pressure..... 3-15
 - Oil pressure..... 3-14
 - Seatbelt..... 3-9
 - SRS airbag system..... 3-11
 - Vehicle Dynamics Control..... 3-20
 - Windshield washer fluid..... 3-19
 - Warranties..... 1
 - Warranties and maintenance..... 8-19
 - Washing..... 10-2
 - Waxing and polishing..... 10-3
 - Wear indicators..... 11-35
 - Wheel
 - Aluminum..... 11-37
 - Balance..... 11-34
 - Nut tightening torque..... 9-6, 12-9
 - Replacement..... 11-37
 - Windows..... 2-20
 - Windshield
 - Washer fluid..... 11-37
 - Wiper and washer switches..... 3-32
 - Wiper blades..... 11-39
 - Wiper deicer..... 3-34
 - Winter
 - Driving..... 8-8
 - Tires..... 8-11, 11-30
 - Wiper and washer..... 3-30
 - Wiper deicer..... 3-34

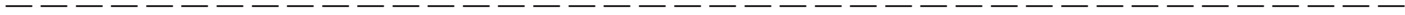
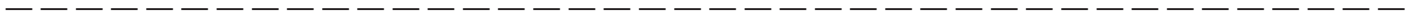
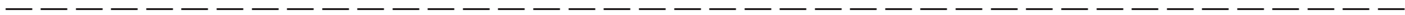

GAS STATION REFERENCE

■ Fuel:

▼ Non-turbo models

Use only **unleaded** gasoline with an octane rating of **87 AKI (90 RON) or higher**.

▼ Turbo models

Use **premium unleaded** gasoline with an octane rating of **93 AKI (98 RON) or higher**.

If 93 AKI (98 RON) fuel is not readily available in your area, refer to “Fuel requirements” ☞7-2.

■ Fuel octane rating

This octane rating is the average of the Research Octane and Motor Octane numbers and is commonly referred to as the Anti Knock Index (AKI). Refer to “Fuel” ☞7-2.

■ Fuel capacity:

18.5 US gal (70 liters, 15.4 Imp gal)

■ Engine oil:

Use only the following oils.

- API classification SM or SN with the words “ENERGY CONSERVING” or “RESOURCE CONSERVING”
- or ILSAC GF-4 or GF-5, which can be identified with the ILSAC certification mark (Starburst mark)

For the complete viscosity requirements, refer to “Engine oil” ☞12-4.

■ Engine oil capacity:

2.5 L non-turbo models: 4.4 US qt (4.2 liters, 3.7 Imp qt)

2.5 L turbo models: 4.5 US qt (4.3 liters, 3.8 Imp qt)

3.6 L models: 6.9 US qt (6.5 liters, 5.7 Imp qt)

The indicated oil quantity is only a guideline and is estimated based on a case when the engine oil is changed with an oil filter. After refilling the engine with oil, the oil level should be checked using an oil level gauge. For more details about maintenance and service, refer to “Engine oil” ☞11-12.

■ Cold tire pressure:

Refer to “Tires” ☞12-9.