

Owner's Manual

Saab 9-3 M2000

Safety	11
Security	29
Convertible	41
Instruments and controls	53
Saab 9-3 Audio System	89
Interior equipment, trunk	111
Starting and driving	133
Car care	167
Maintenance and owner assistance	211
Technical data	219
Index	233

© Saab Automobile AB 1999

Service Readiness, Saab Automobile AB, Trollhättan, Sweden
Printed in Sweden



SAAB



Introduction

This manual provides practical guidance on driving and caring for your Saab.

The Saab 9-3 is available with a 2.0l turbo-engine, 185 hp or 205 hp or a 2.3l turbo-engine, 230 hp.

Although the manual describes the most important differences between model variants, it does not include precise specifications of the different variants. Some differences also occur to meet special legal requirements in different countries.

Importation and distribution of Saab automobiles, spare parts and accessories are handled exclusively by General Motors of Canada Limited in Canada and by Saab Cars USA, Inc. in the U.S.A.

We recommend that you read through the manual before taking the car out for the first

time and that you keep it in the car for future reference.

To find a specific item, use the overviews given on pages 3-6. A list of contents is given at the beginning of each section of the manual, and there is also a comprehensive index at the back of the book.

Supplied with the car is a Warranties and Service Record booklet and a tire warranty folder which specifies the regular maintenance to be carried out. The book also contains important warranty conditions.:



WARNING

WARNING texts warn against the danger of injury if the specified instructions are not followed.

NOTE

NOTE texts warn of potential damage to the car if the recommendations are not followed.

Since the policy at Saab is one of continual improvement, we retain the right to incorporate modifications and to alter specifications during production without prior notice.

If you have any queries concerning your car, its equipment, the warranty conditions or the like, your Saab dealer will be pleased to help.

Best wishes,
Saab Automobile AB

The fitting of accessories that are not approved by Saab Automobile AB can damage other parts of the car.

The specifications, design particulars and illustrations included in the manual are not binding.

Instrument panel

High/low beam _____	71
Parking lights _____	71
Daytime running lights _____	71
Changing bulbs _____	181

High/low beam control stalk _____	71
Direction indicators _____	72
Cruise Control _____	148

Rear fog light _____	73
Front fog lights _____	73

Instrument lighting _____	74
---------------------------	----

Steering-wheel-mounted controls, Audio System _____	105
---	-----

Warning and indicator lights _____	54
Tachometer _____	59
Speedometer _____	59
Odometer and trip meter _____	59
Gauge showing turbo pressure _____	60
Fuel gauge _____	61
Temperature gauge _____	60

Trip computer (Saab Information Display, SID) _____	62
Night panel _____	63
Clock _____	64, 70

Washers and wipers _____	74
Rear-window wiper _____	75
Replacing wiper blades _____	179

Audio system _____	90
Cassette player _____	96
CD player _____	99

Hazard warning lights _____	72
-----------------------------	----

Climate control system: manual _____	76
Climate control system: automatic _____	80
Car care _____	167

Seat heating controls _____	118
-----------------------------	-----

Ashtrays _____	123
Cigarette lighter _____	123

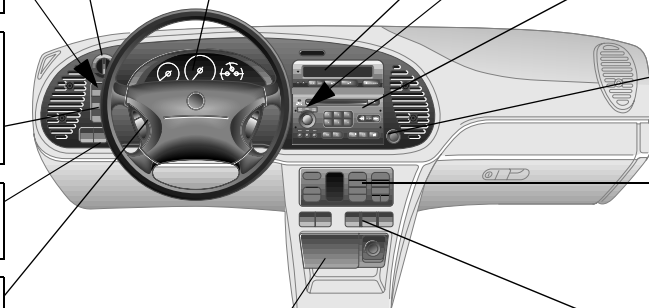

IB731

Exterior

Sunroof _____	120
Convertible _____	42
Washing the car _____	201
Waxing and polishing _____	202
Touching-up of paintwork _____	202
Anticorrosion treatment _____	203
Service program _____	215

Taillights _____	183
Stop lights _____	183
Light switches _____	71
Changing bulbs _____	181

Towing _____	160
Towrope attachment eyes _____	160
Towing a trailer _____	156

Trunk lid lock _____	125
Lowering the rear seat _____	125
Trunk _____	128
Spare wheel _____	130
Tools _____	130
Lighting _____	183

Driving with a roof rack load _____	158
Mounting of roof rack _____	158
Maximum loads _____	220



Tires & Rims _____	192 / 227
Driving in cold weather _____	154
Brakes and braking _____	149
Compact spare wheel _____	195
Changing a wheel _____	196

Hood release handle _____	168
Engine compartment: washing _____	201

Headlight switches _____	71
High/low beam control stalk _____	71
Turn signal & lane change indicators _____	72
Headlamp wipers _____	180
Changing bulbs _____	181

Central locking _____	30
Interior locking buttons _____	31
Trunk lock _____	33
Child safety lock catch _____	33
Car alarm (Anti-theft alarm) _____	35

Fuel filler door _____	138
Refuelling _____	138
Fuel grade _____	224
Fuel gauge _____	61
Fuel economy _____	153

Interior

Internal rearview mirror _____	124
Door mirrors _____	124
Vanity mirror _____	122

Interior lighting switch _____	121
Interior lighting: changing bulbs _____	185

Power steering _____	226
Steering-wheel adjustment _____	118
Airbag _____	22

Safety belts _____	12
Safety-belt care _____	199
Airbag _____	22
Child seats _____	18
Child safety lock catch _____	33

Seat adjustment _____	112
Safety belts _____	12
Seat heating _____	118
Rear seat _____	125
Folding down the rear seat _____	125
Child seats _____	18
Upholstery: cleaning _____	200

Glove compartment _____	123
-------------------------	-----

Gear changing _____	141
Manual transmission _____	141
Automatic transmission _____	141

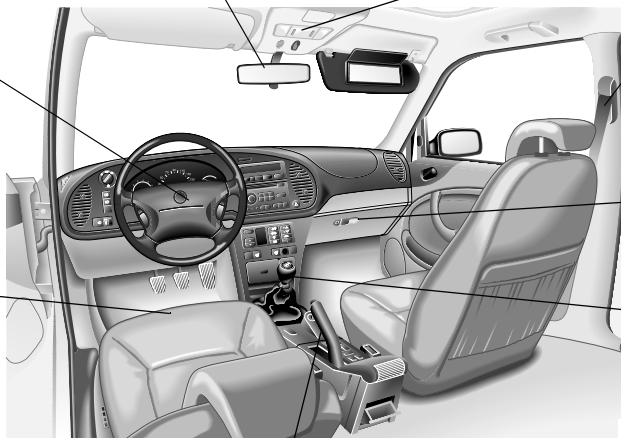

Center console _____	119
Electric windows _____	119
Sunroof _____	120
Convertible _____	42
Ignition switch _____	134
Starting the engine _____	135
Engine break-in period _____	140
Parking _____	151
Driving in hot/cold weather _____	154

Engine bay: turbo

Warning labels _____	7
V.I.N. number _____	229
Engine number _____	229
Gearbox number _____	229
Color coding _____	229

Ignition system _____	225
Drive belt _____	179
Alternator _____	179
Spark plugs _____	225
Catalytic converter _____	137
Simple fault tracing (A/C, ACC) _____	207

Turbo-compressor _____	60
Pressure gauge _____	60
Important considerations for driving _____	136
Technical data: engine _____	223

Manual transmission _____	173
Automatic transmission _____	173
Transmission oil _____	173
Gearbox: technical data _____	226

Engine: description _____	168
Engine oil, level control and topping up _____	172
Engine oil: changing _____	172
Oil grade, viscosity _____	223

Brake system _____	227
Brake fluid _____	176
Brake pads _____	176
ABS brakes _____	149

Fuse panels _____	187
Changing a fuse _____	187
Table of fuses _____	189
Relays _____	191

Coolant, checking and topping up _____	174
Coolant, changing _____	175
Temperature gauge _____	60
Driving in hot weather _____	156
Driving in cold weather _____	154

Washer fluid _____	180
Topping up with fluid _____	180
Washer jets _____	180
Wiper/washer control stalk _____	74

Steering servo _____	177
Fluid checking and topping up _____	177

Battery _____	177
Battery charge _____	177
Jump starting _____	162

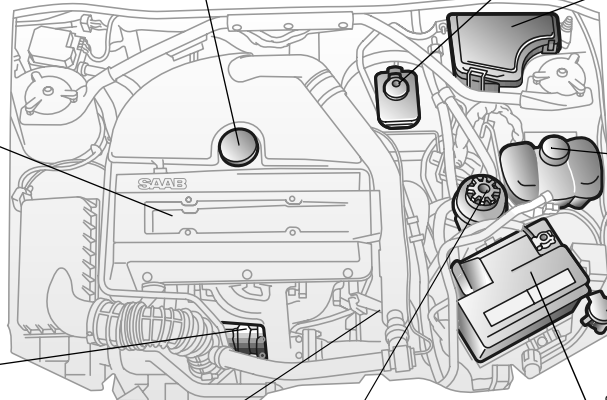

IB 733



CANADA



USA

AIR BAG WARNING

Flip visor over



CANADA

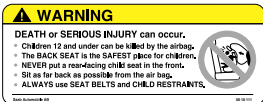

USA

WARNING

DEATH or SERIOUS INJURY can occur.

- Children 12 and under can be killed by the air bag.
- The BACK SEAT is the SAFEST place for children.
- NEVER put a rear-facing child seat in the front.
- Sit as far back as possible from the air bag.
- ALWAYS use SEAT BELT and CHILD RESTRAINTS

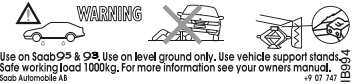
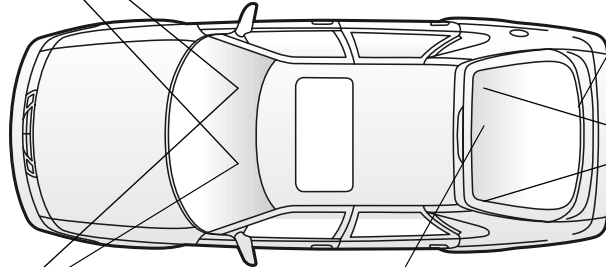

Wheel changing:

Intended for the Saab 9-5 and 9-3. Use the jack only on firm, level ground. Use blocks. Max. jack load: 2200 lbs. (1000 kg). For further information, see the manual.



Belt beam

Warning for pinch risk due to movable parts when beam is in unlocked position.



Long loads

Always SECURE LOAD to prevent it from shifting during transport.

An unsecured load could cause passenger injuries in braking situations or in the event of a collision.

Cover sharp edges with a protective wrap.

- Max. weight 30 lbs. (15 kg).
- Max. length 6 ft. (2 metres).

See your Owner's Manual before securing loads.

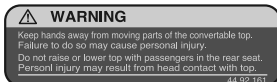

Keep hands away from moving parts of the convertible top.
Failure to do so may cause personal injury.
Do not raise or lower top with passengers in the rear seat.
Personal injury may result from head contact with top.



Soft top, Saab 9-3 Convertible

Push the handle in before driving away.

There would otherwise be a risk of injury.

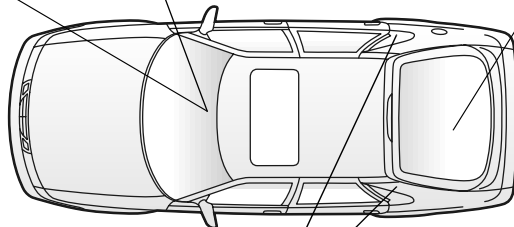

Child lock safety catch

Locked.

The door can not be opened from inside.

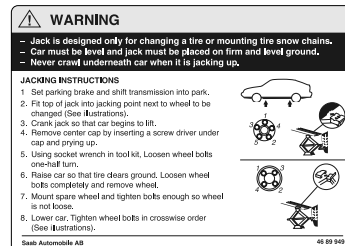

Jack

- The jack is designed solely for use in changing a wheel or fitting snow chains.
- The car must be standing level and the jack must be positioned on a firm, level surface.
- Never crawl under the car while it is raised on the jack.

USE

- Apply the parking brake and engage first or reverse gear; if the car has automatic transmission, select P.
- Fit the jack at the jacking point nearest to the wheel that is to be changed.
- Wind up the jack until the car just begins to lift.
- If there is a wheel cover, remove it by inserting a screwdriver behind it and prying it off.
- Loosen the wheel bolts by half a turn, using the tool in the toolkit.
- Wind up the jack so that the wheel clears the ground. Unscrew all the wheel bolts and take the wheel off.
- Fit the spare wheel and tighten the wheel bolts enough for the bolts and wheel to seat correctly.
- Lower the car. Tighten the wheel bolts in the sequence shown by the figure.

Safety

Safety belts.....	12
Child safety.....	18
Airbag (Supplemental Restraint System "SRS")	22

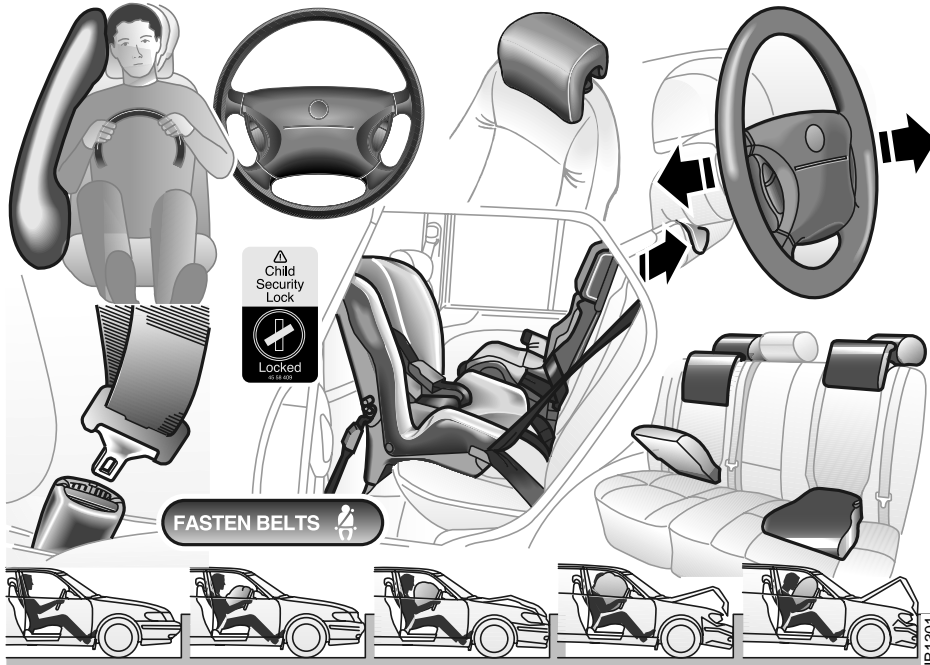

Safety belts

WARNING

Safety belts must be worn **at all times** by all car occupants. Child safety, see page 18.

Check that the tongue of the belt lock engages properly.

The A-pillar area (area beside the windshield) and the headlining of your Saab contain padding designed to reduce head injuries (3 or 5-door only). No modifications to these areas should be made unless done so by your authorized Saab dealer.

Three-point inertia-reel safety belts are provided for all seats.

Research has established that it is dangerous for rear-seat passengers not to wear their safety belts.

Otherwise, in the event of an accident, the rear-seat passengers can be thrown forward against the front-seat backrests, imposing much higher stresses on the front-seat passengers and belts and resulting in needless injury to everyone in the car.

WARNING

For safety reasons, you should adjust safety belts only while the car is stationary.

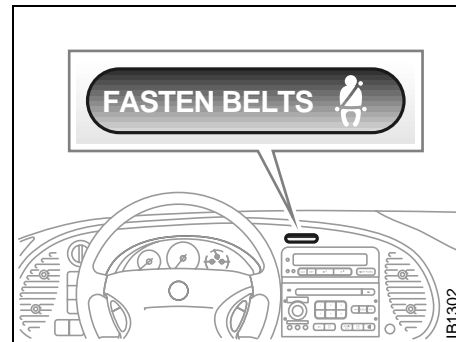

Safety-belt reminder

When the ignition is switched on, the "fasten belts" reminder will light up for 6 seconds or until the driver and any passengers are wearing their belts. An audible alarm will also sound for six seconds or until the driver has fastened his belt.

Safety-belt pretensioners

The belts of the front seats are fitted with automatic pretensioners, which are activated in the event of a severe frontal collision or very violent rear-end collision. They serve to reduce the forward movement of the body by tensioning the belt.

The belt pretensioners do not activate in less severe frontal collisions, nor to side collisions, or rollovers.

WARNING

If the car is involved in a collision, the safety belts, belt pretensioners and other components must be inspected by an authorized Saab dealer and replaced as necessary.

Never make any alterations or repairs to the safety belt yourself but visit an authorized Saab dealer.

Correct position for safety belt

- The lap part of the belt should be pulled as tightly as comfortable and as low as possible across the hips, so that it is just touching the top of the thighs. The shoulder belt should be well in on the shoulder but not touching the neck.

WARNING

Proper positioning of the safety belt is extremely important. An out of position safety belt can result in the wearer sliding underneath the belt in a collision (submarining) and injury can result from the lap portion cutting into the abdomen.

- Check to ensure that the belt is not twisted or rubbing against any sharp edges.
- There should not be any slack in the belt. Pull the belt tight – particularly important when thick outer clothing is worn.



IB816

Sit correctly before putting the belt on

- Refrain from tilting the backrest more than necessary, as the safety belt provides better protection when the seat is in the more upright position.
- Only one person per safety belt!

WARNING

If two people share a belt, they risk injury by being crushed together in the event of an accident.

- For most of the time a safety belt is worn, the retractor will allow the wearer freedom of movement. The retractor locks up automatically if the belt is jerked or withdrawn sharply, the car tilts, the brakes are applied hard or a collision occurs.

- Children who have grown out of a child seat should be restrained by the car's standard three-point belts. Make sure that the shoulder belt is not in contact with the neck or throat. If it is, a booster seat/cushion may be necessary.

! WARNING

Never fasten the safety belt with the shoulder belt behind the body or pull the belt off the shoulder and under the arm.

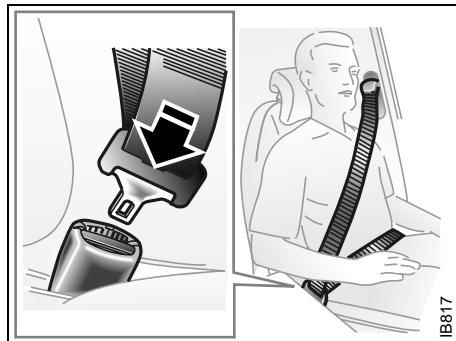

To fasten the belt

Front seat belts

Fasten the belt by pulling the belt and inserting the tongue in the buckle. Check that it is securely fastened.

Because the lower belt-anchorage points are on the seat, the belt buckle follows the movement of the seat during seat adjustment.

Grasp the shoulder belt close to the buckle and pull the belt towards the shoulder to tighten the lap belt part.

The belt must be as far in on the shoulder as possible.

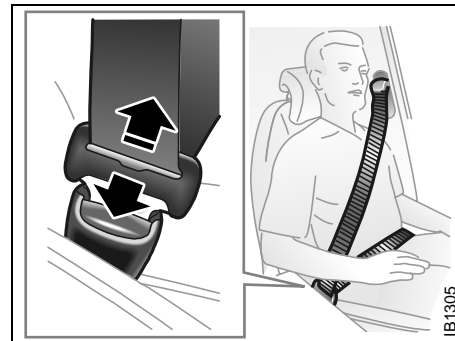

Press the red button to release the belt.

To release the belt, press the red button on the belt buckle, as illustrated.

See page 199 for the checking of belt function, cleaning etc.

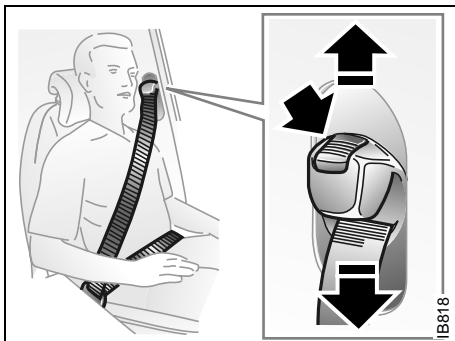

The belt guide on the door pillar

Belt guide

The belt guide on the door pillar can be set to five different heights.

Set the guide as high as possible without causing the belt to chafe against the throat. In the case of a short person the guide can be lowered until the belt comes about an inch (a few centimetres) from the throat but still provides safe restraint.

Raise the belt guide by pushing it upwards to the desired position. To lower it, the release button must first be depressed. Check that it has engaged in its new position by pulling up and down.



Safety belt use during pregnancy

Pregnant women must **always** wear a safety belt to protect both themselves and the unborn child.

The lap portion of the belt should be worn as low as possible across the hips – below the abdomen throughout the pregnancy.

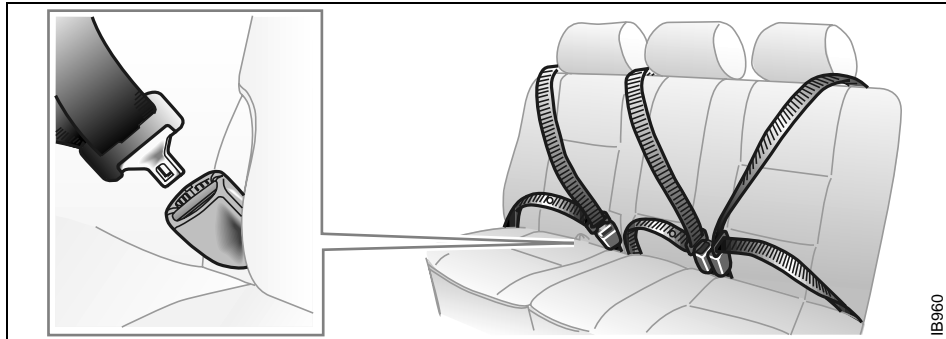

IB960

Safety belts, rear seat (the central head restraint is an accessory)

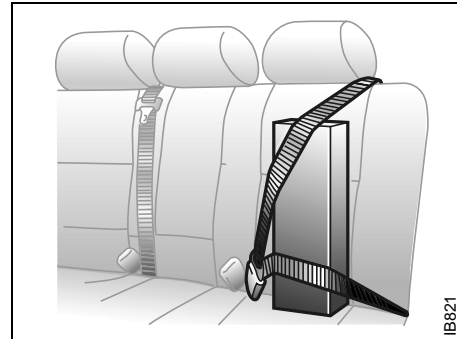

IB821

Securing a load on the rear seat

Safety belts, rear seat

Three-point safety belts are provided for all three rear-seat passengers (2 for Convertible model).

Fasten the belts by pulling the belt across you and inserting the tongue into the buckle. Check that it is securely fastened.

Grasp the shoulder belt close to the buckle and pull the belt towards the shoulder to tighten the lap belt part.

The belt must be as far in on the shoulder as possible.

Press the red button on the belt buckle to release the belt.

WARNING

- Make sure that the belt does not become trapped when the backrest is folded down or raised (see page 125).
- If you must carry an item of luggage on a seat, ensure that it is held securely by the safety belt. This will reduce the risk of injury by flying objects in the event of an accident.
- Protect the belt from sharp edges.

 **WARNING**

Safety belts are designed to bear upon the bony structure of the body, and should be worn low across the front of the pelvis or the pelvis, chest and shoulders, as applicable; wearing the lap section of the belt across the abdominal area must be avoided.

Safety belts should be adjusted as firmly as possible, consistent with comfort, to provide the protection for which they have been designed. A loose belt will greatly reduce the protection afforded to the wearer.

Care should be taken to avoid contamination of the webbing with polishes, oils and chemicals, and particularly battery acid. Cleaning may safely be carried out using mild soap and water. The belt should be replaced if webbing becomes frayed, contaminated or damaged.

It is essential to replace the entire assembly after it has been worn in a severe impact even if damage to the assembly is not obvious.

Belts should not be worn with straps twisted.

Each belt assembly must only be used by one occupant; it is dangerous to put a belt around a child being carried on the occupant's lap.

 **WARNING**

No modifications or additions should be made by the user which will either prevent the safety belt adjusting device from operating to remove slack, or prevent the safety belt assembly from being adjusted to remove slack.

Child safety



! WARNING

- Children must **always** be suitably restrained in the car.
- NEVER put a child seat in the front.
- Children 12 and under can be killed by the airbag.
- The **BACK SEAT** is the **SAFEST** place for children.
- Sit as far back as possible from the air bag.

The same attention must be given to child safety in the car as is given to adults. Children travel most safely when properly restrained, but restraints must be suitable for the size of the child. Always follow the child seat/booster cushion manufacturer's instructions when installing these devices in your vehicle.

Make sure you are acquainted with the legal requirements for seating children in the car.

Make sure that it is possible to fit a child restraint in accordance with the manufacturer's child seat instructions

When fitting child seats in cars you must always read the instructions supplied by the manufacturer.

Lockable belt tongue

In fitting a child seat that is intended to be secured in position by the lap portion of the safety belt, make use of the locking function of the buckle.

Locking the lap portion of the belt lessens the risk that the seat will work loose while the car is in motion.

The button for the locking function is located on the back of the buckle.

- 1 Position the child seat in the back of the car.
- 2 To activate the locking function, move the locking button on the tongue of the belt to the position marked "CHILD SEAT" (item 1 in the figure) in order to activate the locking function.
- 3 Secure the base of the child seat with the lap portion of the safety belt in accordance with the installation instructions accompanying the child seat.
- 4 Grasp the shoulder part of the safety belt and pull it upwards to tighten the lap portion against the child seat.

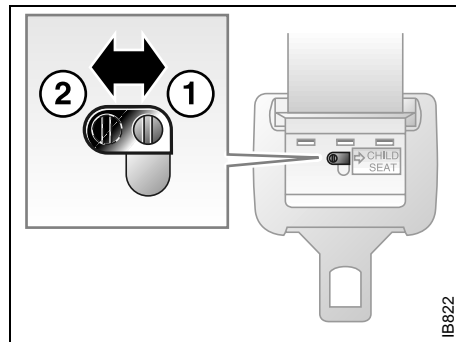

Locking the lap belt

- 1 Locked
- 2 Unlocked

5 Check for correct locking function by pulling on the lap portion of the belt. The belt must not unreel.

Child tether anchorages



Child restraints with a tether strap must be anchored according to law.

! WARNING

Child tether anchorages are designed to withstand only those loads imposed by correctly fitted child restraints.

Under no circumstances are they to be used for:

- Adult safety belts.
- Harnesses.
- Attaching other items or equipment to the vehicle.
- Load securing device.

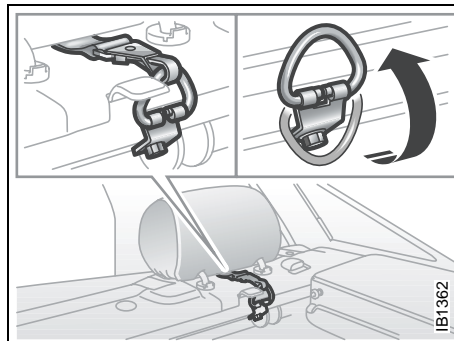

*Child tether anchorage, Coupé and 5-door models.
The tether strap is not a part of the child tether anchorage.*

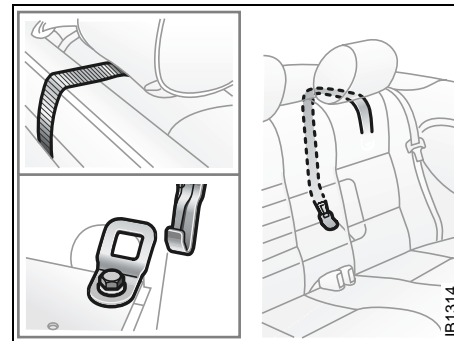

*Attaching tether strap hook to anchorage, Convertible.
The tether strap is not a part of the tether child anchorage.*

Integrated booster seat (accessory)

Integrated booster seats are available as part of the rear seat backrest.

This child restraint is designed for use by children who weigh between 33 and 80 lbs. (15 and 36 kg) and are between 38 and 54 inches (970 and 1370 mm) in height.

A child sitting in an integrated booster seat must use the car's regular lap and shoulder belt. Regardless of the child's weight and age, proper contact between child and belt is vital. Always make certain that the seat is undamaged and is kept clean so that it will function properly.

This child restraint system conforms to all applicable motor vehicle safety standards.

Folding out

- 1 Press in the latches and lift and remove the car's regular head restraint. Turn it 180° and remount it. Make certain that it is locked securely in place.
- 2 Lift up the booster seat's headrest.
- 3 Pull out the upper part of the opener strap and lower the seat itself. Make certain that it is locked in the lowered position.

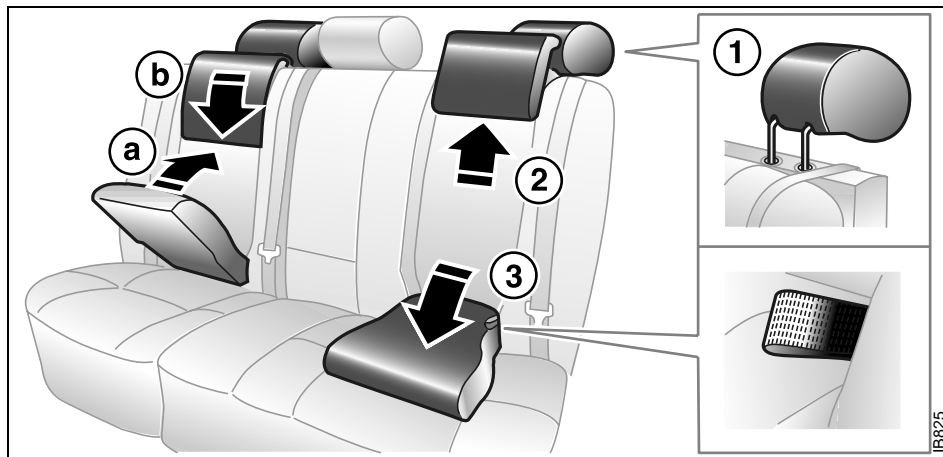

Fasten the belt

- See that the child is seated as far back as possible against the back support.
- Adjust the booster seat's head support so that its center is at ear height.
- To attach the belt, pull it out slowly and insert the latch plate into the buckle. Make certain the latch plate is properly engaged in the buckle.
- The lap portion of the belt must be positioned low on the pelvis, and the shoulder strap must be as far in on the shoulder as possible without chafing against the child's neck or causing discomfort.
- The belt must contact the body firmly to provide the best protection. Pull up on the

shoulder strap to tension the belt properly.

- Make certain the belt moves freely between the retractor and the buckle.

Folding booster seat

- a Pull the upper part of the release strap out and fold up the seat itself. Make sure that it is locked firmly in its folded-up position.
- b Press the booster seat's headrest all the way down.
- c Press in the latches on the car's regular head restraint. Remove it, rotate it 180° and remount it. Make certain it is locked correctly.

⚠ WARNING

- Use only the vehicle's lap and shoulder belt system when restraining the child in the booster seat.
- The seat must not be modified or changed in any way.
- Do not leave a child alone in a car without supervision.
- The car's regular head restraint must always be turned 180° back to its original position after the integrated booster seat is folded away.
- Check that the belt is not twisted or rubbing against any sharp edges.

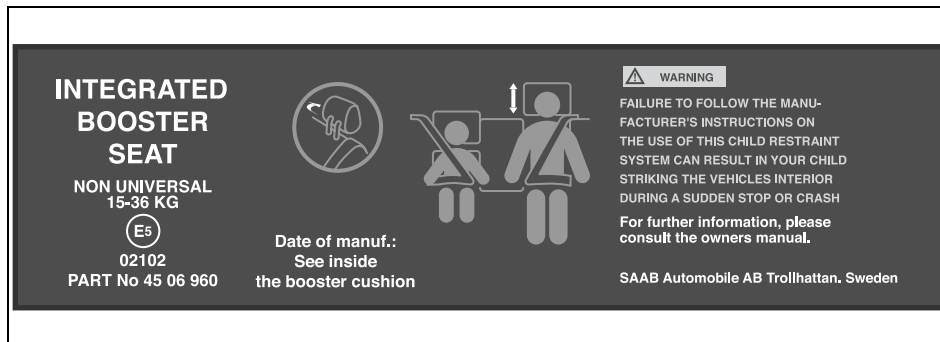

Label in integrated booster cushion

⚠ WARNING

Failure to follow all the manufacturer's instructions on the use of this child restraint system can cause your child to strike the vehicle's interior during a sudden stop or crash.

Airbag (Supplemental Restraint System "SRS")

⚠ WARNING

To reduce risk of injury:

- **Always** wear your safety belt.
- **Always** adjust your seat so that you are as far back as possible but still able to reach the steering wheel and controls comfortably.
- Children 12 and under or shorter than 55 inches (140 cm) should **always** travel in the rear as the vehicle is equipped with an airbag on the passenger side.

The supplementary restraint system (SRS) comprises an airbag in the steering wheel, a front passenger airbag and side airbags in the front seats.

The system supplements the protection provided by the safety belts to further enhance the safety of occupants.

If a fault is detected in the SRS, the AIR BAG warning light on the main instrument panel will come on (see pages 56 and 24).

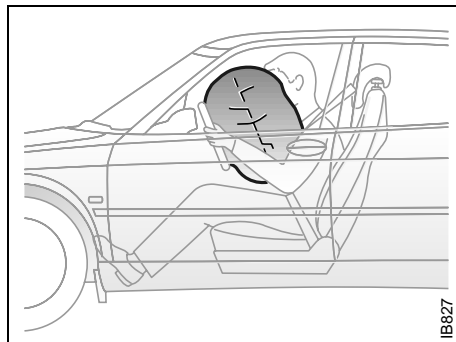

Airbag in course of inflation (driver's side)

When the system is triggered by impact of a frontal collision, the airbags in the steering wheel and passenger side of the dash board are inflated, after which they deflate through vents in the back of the bags.

The entire process takes less than 0.1 second – literally, faster than the blinking of an eye.

These airbags are triggered only by moderate to severe frontal or near-frontal collisions. They will not be activated by minor front-end impacts, rear-end or side impacts, or by the car rolling over.

Side airbags, see page 27.

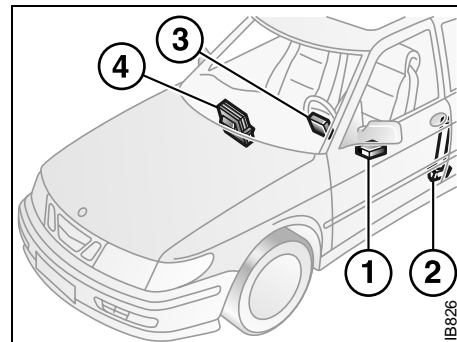

SRS (airbag) system with belt pretensioners

- 1 Electronic control module and sensor
- 2 Belt pretensioners (for both front safety belts)
- 3 Steering wheel with integral airbag
- 4 Recess for airbag on passenger's side

Operation of the airbag in a front-end collision.



Moment of impact.



Sensor detects retardation and sends a signal via the control module to a gas generator that inflates the airbag.

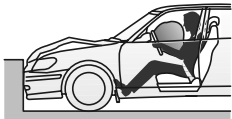

The inflating airbag cushions the driver.



Airbag now fully inflated.



The steering column has collapsed and the airbag starts to deflate.

IB828

! WARNING

- Even if the car is equipped with an SRS (airbag), safety belts must still **always** be worn by all occupants.
- Note that because an airbag inflates and deflates extremely rapidly, it will not provide protection against a second impact occurring in the same incident. **Always** use your safety belt.
- Always sit with the whole of your back in contact with the backrest of the seat, and with your seat as far back as is practical. This is to reduce the risk of injury from contact with the backrest of the seat when the airbag inflates and also because the airbag needs space in which to inflate.
- Never attach anything to the steering wheel or passenger side of the instrument panel, as this could result in injury if the airbag should inflate. The same applies to anything you might have in your mouth, such as a pipe, for instance.
- Some components of the airbag will be hot for a short time. In some circumstances the airbag can cause burns or abrasions to the body when the airbag inflates/deflates.

- Never rest your hands or forearms on the steering-wheel center padding.
- If the AIR BAG warning light remains on after the car has been started or comes on while you are driving, have the car checked immediately by an authorized Saab dealer. The warning light could signify that the airbags may not inflate in a crash, or they could even inflate without a crash.

Front passenger seat **WARNING**

Never secure a rear-facing child seat in the right front seat of a car equipped with a passenger airbag. Inflation of the airbag in the event of an accident could seriously injure or kill a child.

The airbags are interconnected and have a common warning light, AIR BAG. The passenger airbag module is housed in the fascia above the glove compartment and is marked "SRS AIR BAG".

Both airbags will be inflated in the event of a moderate to severe frontal, or near-frontal collision, even if the passenger seat is unoccupied.

 **WARNING**

- Children 12 and under can be killed by the airbag.
- The back seat is the safest place for children.
- Never allow a child to stand in front of the seat or to sit on the lap of a front-seat passenger. Serious injury or death could result if the airbag is inflated in a collision.
- Never place anything on the dash or in front of the seat as, in addition to being a hazard to passengers, this could interfere with the function of the airbag in the event of an accident. The same applies to the mounting of accessories on the dash.
- Keep feet on the floor - never put feet up on the dash, on the seat or out of the window.
- Do not carry anything in your lap.

AIR BAG warning light **WARNING**

- If the airbag readiness light stays on after you start your vehicle, it means the airbag system may not be working properly.
- The airbags in your vehicle may not inflate in a crash, or they could even inflate without a crash.
- To help avoid injury to yourself or others, have your vehicle serviced right away if the airbag readiness light stays on after you start your vehicle.

SRS servicing

The SRS must be inspected as part of the normal service program but otherwise may be regarded as maintenance-free.

Scrapping or working on airbag and belt pretensioners

WARNING

- Under no circumstances should any modifications be made that affect the steering wheel or the airbag's electrical circuitry.
- Before starting any welding work on the car, always disconnect the negative (-) battery lead and cover the conductor.
- Airbags and belt pretensioners must be deployed under controlled conditions before the car is scrapped or any of the system's components are removed. Airbags or belt pretensioners that have been deployed as a result of an accident must be replaced by new ones.
- Airbag-system components must never be transferred for use in another vehicle.
- All work involving the scrapping or replacement of airbags or belt pretensioners must only be carried out by knowledgeable personnel.

Frequently asked questions on function of the airbag

Do you still need to wear a safety belt if airbags are fitted?

Yes, always! The airbag merely supplements the car's normal safety system. Moreover, the airbag will only be actuated in a moderate to severe frontal, or near-frontal collision, which means, of course, that it provides no protection in minor frontal collisions, major rear-end or side-on collisions or if the car rolls over.

The safety belts help reduce the chance of the car occupants from being thrown around and injured inside the car.

But they also ensure that, if a collision occurs in which the airbags are inflated, the airbag will make the optimum contact with the occupant, i.e. square on from the front. If the occupant meets the airbag in an offset position, the protection afforded will be reduced.

In addition, airbags provide no protection against a secondary impact occurring in the same incident. So there is no doubt about the benefit of wearing safety belts at all times.

Do not sit too close to the airbag: it needs room to inflate.

The airbag inflates very quickly and powerfully in order to protect an adult person in a serious frontal collision.

How do I position the seat to leave room for the airbag to inflate?

Don't have your seat too far forward.

Recline the seat back to increase the distance between you and the airbag. For short drivers, special accessory pedal extensions are available through your Saab dealer.

Airbags inflate extremely rapidly and with great force - to be fast enough to protect an adult in the seat.

When does the airbag inflate?

The airbag will only be inflated under certain predetermined conditions in a moderate to severe frontal, or near-frontal collision, depending on such factors as the force and angle of the impact, the speed of the car on impact, and the resistance to deformation of the impacting object.

The airbag can only be activated once in the same incident.

Do not attempt to drive the car after an airbag has been inflated, even if it is possible.

What won't trigger the airbag?

The airbag will not be activated in all front-end collisions. For instance, if the car has hit something relatively soft and yielding (e.g. a snow drift or a hedge) or a solid object at a low impact speed, the airbag will not necessarily be triggered.

How loud is the inflation?

The noise of the inflation is certainly loud, but it is very short-lived and will not damage your hearing. For a short time afterwards you could experience a buzzing noise in your ears.

Most people who have experienced it cannot remember the noise of the inflation at all - all they remember is the noise of the crash.

Can you still use a child seat in the front if a passenger airbag is installed?

Definitely not!

Children 12 and under can be injured or killed by the airbag.

The BACK SEAT is the SAFEST place for children.

NEVER put a child seat in the front.

Are the smoke and fumes given off when the airbag operates at all harmful?

Most people who have remained in a car with little or no ventilation for several minutes complained only of minor irritation of the throat and eyes. Avoid as far as possible getting dust on your skin as there is a risk of skin irritation.

If this trouble persists, you should consult a doctor.

If you suffer from asthma, the incident may bring on an attack, in which case you should follow the normal procedure advised by your doctor. It is advisable to consult a doctor afterwards.

What should I do if the AIR-BAG warning light comes on?

If the warning light is on, it means that a fault has been detected in the system. The airbag cannot be relied on to operate as intended and it might even be activated erroneously. You should therefore take the car to an authorized Saab dealer as soon as possible.

 WARNING
When an airbag is inflated there is dust in the air. Because the dust/smoke can, in certain cases, cause irritation to the skin, the following precautions should be taken: <ul style="list-style-type: none">• As soon as possible, wash any exposed skin using a mild soap and water.• If there is irritation of the eyes, flush them liberally with clean water for at least 20 minutes.



Side airbag

Side airbags are housed inside the backrests of the front seats and are designed to protect the driver and front passenger in the event of a side impact.

In a side impact, only the airbag on that side will be activated, and only then if certain pre-determined conditions are met such as the force and angle of the impact, the speed of the car on impact, and at which point on the car's side the impact occurs.

The sensors, which are fitted in the front doors, sense the rise in pressure caused by the door panel being pressed in during an impact condition. The side airbag trigger will be commanded based on the characteristics of this pressure rise.

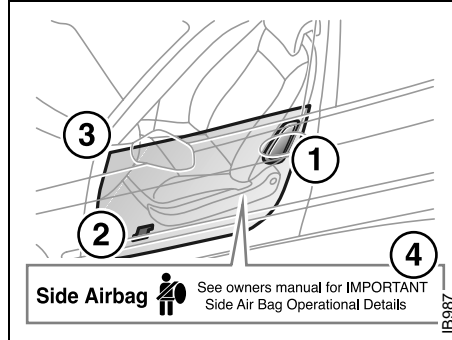

Side airbag, components

- 1 Side airbags (SRS)
- 2 Sensor
- 3 Moisture barrier
- 4 Label on seat

WARNING

- This car is equipped with side airbags and no extra interior trim should be fitted. Failure to observe this warning could result in the side airbags not inflating as intended and thus not providing the intended protection either.
- Never place any object in the area that would be occupied by the inflated airbag.

- For optimum protection, sit upright in the seat, with your safety belt correctly fastened.
- The sensors for the side airbags are fitted in the doors.
- We advise against doing any work on the doors that could affect the moisture barrier in the door or the airbag sensors. It is essential that the moisture barrier (thick plastic film) in the door is not damaged in any way.
- Improvement of the anticorrosion treatment of the doors should only be carried out by an authorized Saab dealer. Otherwise there is a risk that the side impact sensor and the moisture barrier in the door could be damaged.
- The side airbags will inflate only in the event of a side impact; not in the event of a front or rear-end collision or of the car's rolling over.
- Damage to the seat cover, or the seat seam, in the area of the side airbag must immediately be repaired by an authorized Saab dealer.
- Do not modify the speaker installation in the front doors or install speakers other than those specifically approved by Saab.

Security

Doors.....	30
Central locking.....	30
Car alarm	35

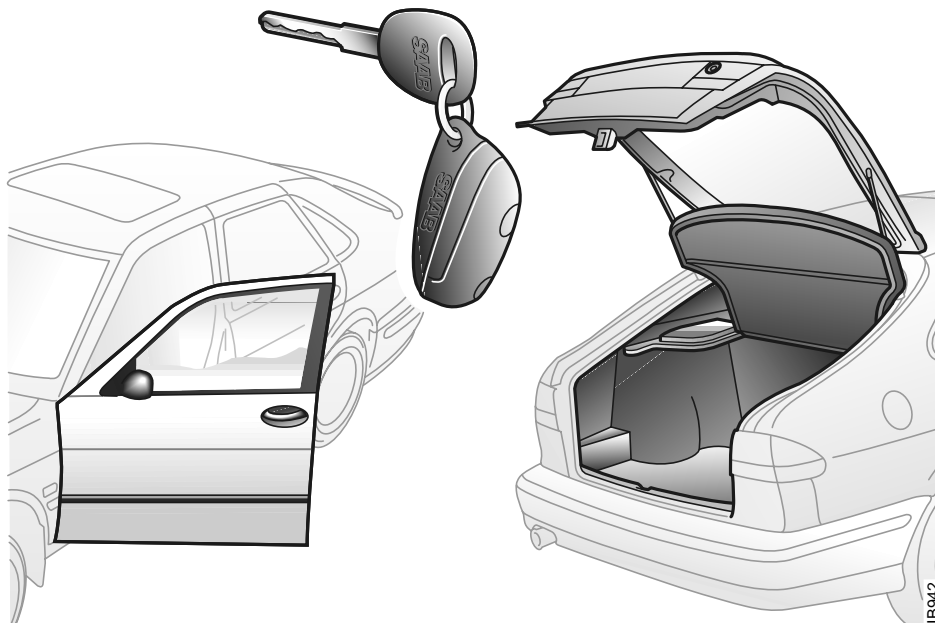

IB942

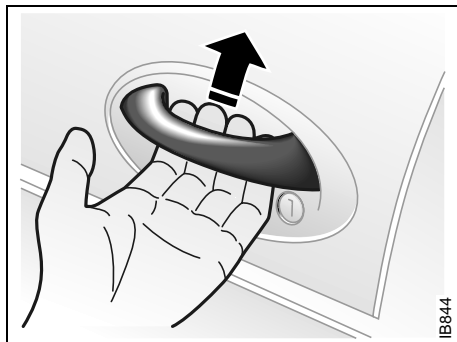

IBB44

Door handle

Doors

Opening handle

Open the door by **lifting** the opening handle from below.

If the door is stuck (e.g. if frozen), hold the handle from above to secure a better grip.

Central locking



WARNING

Leaving children or pets unattended in a locked car is dangerous. It is also dangerous to leave children in a vehicle with the ignition key. A child or others could be badly injured or even killed.

Key / Remote control

The key fits all the locks on the car. The spare key without the black key grip only fits the door locks.

The key supplied with the car has a code number on a black plastic tag that needs to be quoted for ordering additional keys. You should therefore make a careful note of the number.

The key contains a unique electronic code for your car. When the key is inserted in the ignition, the code is checked. If it matches, the car can be started.

Two keys/remote controls are supplied with the car. It is possible to have up to four at one time that are coded for your car. If one is lost, contact your authorized Saab dealer to obtain a replacement. If an additional remote or key is to be added, all of the original keys and remotes must be brought to the dealer so that the control module can "learn" to recognize the new components.

For this reason, we strongly advise you to take two keys with you on long journeys and to keep them separate.

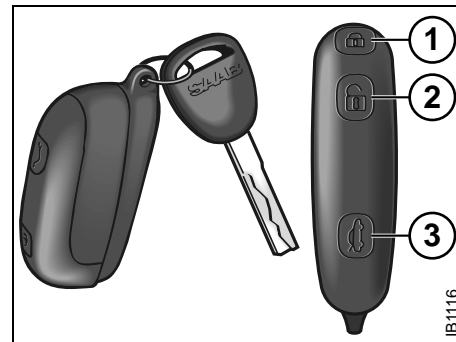

IB1116

Remote control

- 1 To lock
- 2 To unlock
- 3 To unlock trunk lid
To open trunk lid (Convertible)

The remote control contains delicate electronics and should therefore not be exposed to water or handled roughly.

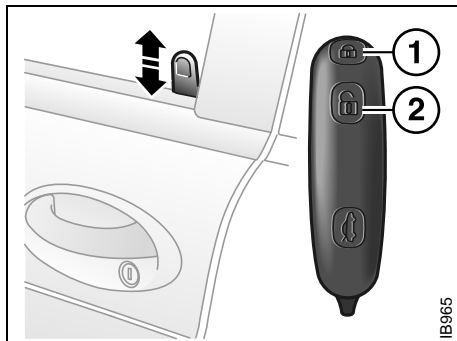

Locking / unlocking by remote control

- 1 To lock
- 2 To unlock

Electronic starting interlock (immobilizer)

Each time the key is removed from the ignition, the electronic starting interlock is activated and the car is thus immobilized, see also page 36.

Locking/unlocking the car

When the car is locked and unlocked with the remote control or the key (see page 35), the theft alarm is also affected.

To lock by remote control (1)

Press  once on the control: all doors locked.

The hazard warning lights will flash once to confirm.

The trunk lid cannot be opened now from inside using the switch on the driver's door.

To unlock by remote control (2)

Press  once on the control: driver's door is unlocked. Press a second time to unlock the rest of the doors.

The hazard warning lights will flash twice to confirm.

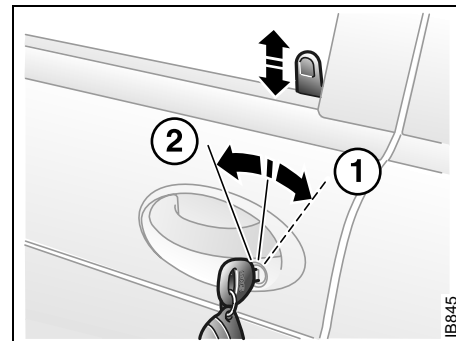

Central locking

- 1 To lock
- 2 To unlock

Locking by key (1)

Turn the key clockwise: all doors and trunk lid locked.

The trunk lid cannot be opened now from inside using the switch on the driver's door.

Unlocking by key (2)

Turn the key counterclockwise once: the driver's door unlocked.

Turn the key counterclockwise twice: all doors, but not trunk lid, unlocked.

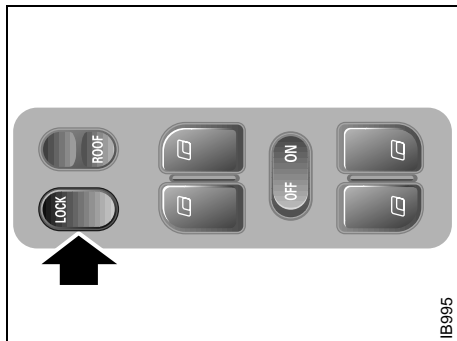

Switch for operation of central locking

The central locking can also be operated from inside the car by means of the switch on the center console (except on Convertibles).

- To lock all doors: press the symbol side of the switch once.
- To unlock the driver's door: press the switch once.
- To unlock all doors: press the switch twice.

This switch is inoperative when the car is locked from the outside.

The interior locking buttons on each door affect only the respective door on sedan. The driver's door lock button will lock/unlock both on the Convertible.

If the car is left with the doors open, the interior lighting will be switched off automatically after 20 minutes, to prevent a dead battery.

! WARNING

Having the doors locked when you are driving will reduce the likelihood of:

- Children, in particular, opening doors and falling out of the car.
- Intruders entering the car when it is moving slowly or at a standstill.
- Injury resulting from a door bursting open in the event of an accident.

However, you must also be remembered that locked doors can hamper rescuers in the event of an accident.

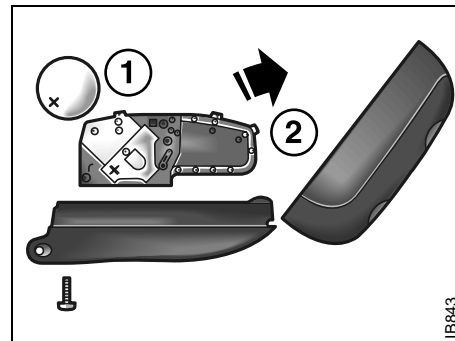

Changing the battery of the remote control

- 1 Battery
- 2 Control module

Changing the remote-control battery

When the battery voltage in the remote control falls below a predetermined level the SID will issue the following message: REPLACE KEY BATTERY. Press the CLEAR button on the SID to acknowledge this message. You must then replace the battery without delay to avoid malfunctions. The life of the battery is 4-5 years. After changing the battery you must press the unlocking button of the remote control four times (or until the door locks cycle) while the car is within the range of the remote control in order for the control module to recognize the remote.

Battery type: Panasonic CR 2032, 3V lithium. Avoid putting fingerprints on the flat sides of the battery.

Dispose of the old battery properly when you buy a new one. These batteries contain substances that are environmentally hazardous.

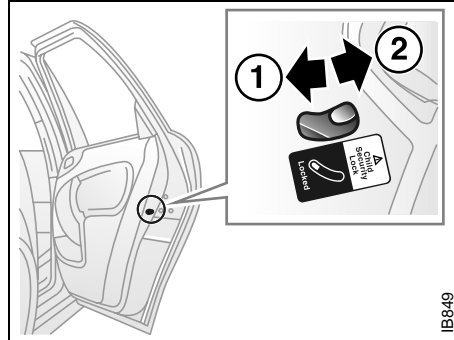

Child safety lock catch

- 1 Engaged
- 2 Disengaged

Child safety locks

The rear doors have child safety locks that are activated by a button next to the door latch on the end of the rear doors.

Shift the button up or down according to the label on the door in question.

When the child safety lock is in the locked position, the door cannot be opened from the inside, but can be opened from the outside.

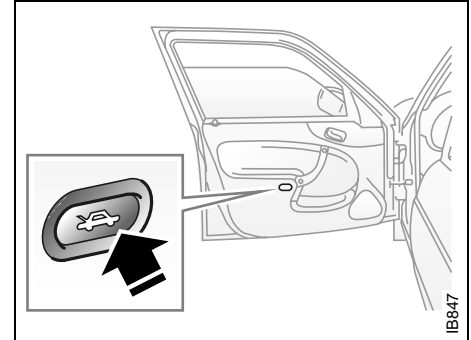

Trunk switch

Trunk lock

The trunk does not unlock when the other doors are unlocked. The trunk button on the driver's door is inoperative when the car is locked or moving at a speed greater than 2.7 mph (4 km/h).

To unlock

The trunk is unlocked using:

- The  button on the remote control.
- The trunk switch on the inside of the driver's door (if the car is unlocked and at a standstill).
- The key in the trunk lock.

The trunk is opened using the opening handle above the number plate.

Unlocking the trunk with the remote control is confirmed by the direction indicators blinking three times.

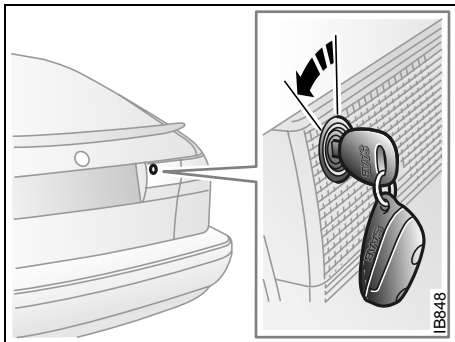

Unlocking the trunk lid with the key

Certain central lock-system functions can be reprogrammed by an authorized Saab dealer

See page 231.

If the car has an alarm, and it is armed (the car is locked), the alarm will sound if the trunk is unlocked with a key. However, if the trunk is opened using the remote control, the alarm will not be triggered.

To lock

The trunk is locked in the following ways:

- When locking all the car's doors with the



button on the remote control.

- With the  switch on the center console (except on Convertible models).
- With the key in the driver's door.

Car alarm

WARNING

Leaving children or pets unattended in a locked car is dangerous. It is also dangerous to leave children in a vehicle with the ignition key. A child or others could be badly injured or even killed.

The car alarm (anti-theft system) is activated/deactivated when the car is locked/unlocked by the remote control or by the key.

All the doors plus trunk lid and hood are monitored by microswitches, and window-glass sensors will trigger the alarm if any glass is broken.

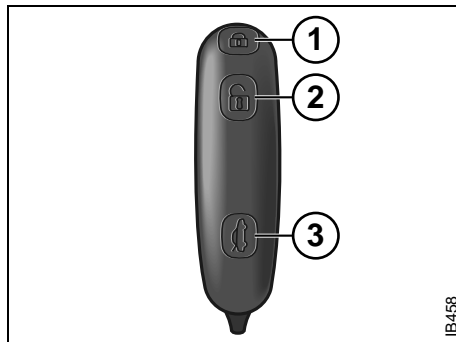

Remote control

- 1 Activate/lock
- 2 Deactivate/unlock
- 3 Deactivate trunk, sensors/unlock trunk lid

Electronic starting interlock (immobilizer), see page 36.

The car alarm is armed 10 seconds after the car has been locked by the remote control. During this ten-second delay period, the doors, trunk lid and hood may still be opened without the alarm being triggered.

The LED indicator on the dash will be on continuously during this period, at the end of which it will start to flash (once every third second) when the alarm arms.

If a door or the trunk lid or hood has been left open when the car is locked, the LED on the dash will flash (three times per second) for ten seconds to indicate that something is wrong.

Check to ensure that all the doors, plus trunk lid and hood, are closed properly.

If the fault persists (LED flashing when renewed attempt made to activate the car alarm by remote control), lock the car using the key instead. The car alarm may not have been activated and you should get in touch with an authorized Saab dealer.

Be sure everyone using the car is familiar with how both the car alarm and the locking system work. This will avoid the alarm being triggered inadvertently.

Activating the car alarm

The car alarm (anti-theft system) is activated/deactivated when the car is locked/unlocked by the remote control or by the key.

The car alarm cannot be activated if the driver's door is open or if the ignition switch is in position ON.

If, on the other hand, one of the other doors or the trunk or hood is open or opened and not closed again during the 10-seconds delay period, it will be excluded from the alarm function.

If it is then closed, a new delay period of ten seconds will start, and the door (or trunk or hood) will once again be secured by the alarm system.

As usual, the LED will be on continuously during the new delay period and will start to flash every three seconds after the 10-seconds period has elapsed.

Window glass sensor

The car-alarm (anti-theft system) incorporates a sensor that monitors the window glass for the sound of breakage. The sensor is fitted inside the rear dome light (on Convertibles: in the front interior light).

To avoid false alarms, such as the alarm being triggered by children or pets left inside the car, the sensor can be temporarily disabled.

To disable the sensor

To disable the sensor, first turn off the ignition and remove the key from the switch. Next, press and hold the NIGHT PANEL button until "DOOR ALARM ONLY" appears on the SID and a chime sounds. The car alarm must now be activated within three minutes, or the glass sensor will become active again.

The glass sensor will be enabled again automatically the next time the car is unlocked. The sensor can also be enabled again by repeating the procedure for disabling it. When the sensor has been enabled, "FULL THEFT ALARM" will appear on the SID.

If a fault is detected in the glass sensor, "SERVICE THEFT ALARM" will appear on the SID.

9-3 Convertible: when the car is parked with the soft top down, the glass sensor will be automatically disabled.

Electronic starting interlock (immobilizer)

When the key is inserted in the ignition, a signal is sent to the receiver. If the signal is verified, the engine can be started.

Each time the key is removed from the ignition, the electronic immobilizer is activated. If a fault is detected (e.g. in the transmitter) "KEY NOT ACCEPTED" will appear on the SID.

In this case, you can still start the car if you turn the ignition key to ON and press one of the buttons on the remote control.

Take the car to an authorized Saab dealer to have the system checked.

The LED on the top of the dash double-flashes when the car is immobilized.

Alarm signals

When the car alarm is armed, it will be triggered if any door, the trunk lid or hood, is opened, or if a window is broken.

The alarm will also be triggered if an attempt is made to bypass or short-circuit the ignition switch, or to disconnect the battery.

If the alarm is triggered, the following alarm signals will be set off:

- Flashing of hazard warning lights for five minutes.
- Siren wailing for 30 seconds.

The alarm signals will stop if the alarm is deactivated (car unlocked) during the alarm period.

NOTE

- It is possible to inadvertently deactivate the car alarm and at the same time unlock the car, if the button on the remote control is pressed by mistake when the control is still within range of the car.
- When locking the car by remote control in extremely cold weather, it is advisable to check that the lock system has operated properly. To do so, check that the interior locking buttons are all down.
If not, unlock and relock the car again.

Panic-function

In the car alarm system is a function called "Panic-function".

To activate panic function:

- Push and hold one of the buttons on the remote control for 2 seconds, or if you are sitting inside the car...
- Push the LOCK-switch on the center console for 2 seconds (not Convertibles).

These actions will trigger the alarm (hazard warning lights and siren).

To deactivate panic function:

- Push one of the buttons on the remote control, push the LOCK-switch in the center console, turn the key in one of the doors or turn the ignition to ON.

When the panic-function is activated the car will be locked/unlocked depending upon which button was pushed.

When the ignition is ON the panic-function cannot be activated.

Overview of functions

Locking/ activation	Hazard warning lights flash once (0.5 seconds). Horn chirps once. The LED will come on for 10 seconds.
Unlocking/ deactivation	Hazard warning lights flash twice. Horn chirps twice. The LED will come on for two seconds.
Unlocking/ deactivation of trunk lid alarm	Hazard warning lights flash three times. Horn chirps three times. The LED will flash three times per second for 10 seconds.
Alarm triggered	Hazard warning lights flash for 5 min. Siren wails for 30 seconds. To switch off the alarm, deactivate the system in the normal way (unlocking) by unlocking the door with the key or the remote
Window-glass sensor	The sensor detects if any window is broken and triggers the alarm. To disable the sensor, see page 36.
Remote control	The range of the remote control is normally 5-10 yds. (5-10 metres), although it can be substantially more than this in ideal conditions. If a remote control is lost, the new one will have to be programmed from one of the remaining remote controls to match the car's unique security code. Get in touch with an authorized Saab dealer. Your dealer will need your second remote to program a new one
	If another remote or key is desired (up to total of 4), all keys and remotes must be present when programming additional ones.

Battery for remote control	The battery for the remote control will normally have a life of 4-5 years. When the battery needs changing, "REPLACE KEY BATTERY" will appear on the SID. After fitting a new battery, press the unlock button on the remote control at least four times in succession, so that the car alarm can recognize the signals from the transmitter. If the remote control has been exposed to very low temperatures, it may not function properly. If this happens, warm it in your hands for a few minutes. If the remote control is not working, it may be because the code signal has not been synchronized with that in the control module for the car alarm. To rectify this, press the unlock button on the remote control at least four times in quick succession. When it is recognized, the door locks will cycle.
Car-battery voltage	If the car-battery voltage is lost while the alarm is activated - for instance, if the battery has died - the car alarm will be deactivated. Once battery voltage is present again, the alarm will revert to its status at the time the voltage went down. If the battery is disconnected, e.g. in an attempt to break into the car, the alarm will be triggered

Alarm signals may differ between model variants for different countries.

Some of the car-alarm functions can be reprogrammed – consult your Saab dealer for further details (see page 231).

Overview of, LED signals and SID messages

Status	LED signal
Activation (during 10-second delay).	Comes on for 10 seconds.
Alarm activated (after delay).	Flashes once every third second.
Deactivation.	Comes on for 2 seconds.
Alarm not activated.	Off.
Door, trunk lid or hood open or opened during delay period.	Flashes three times per second for 10 seconds.
Unlocking the trunk lid.	Flashes three times per second for 10 seconds.
Closing of door, trunk lid or hood after delay period.	Comes on for 10 seconds.
Car immobilized but not locked. Car alarm not activated.	Flashes twice at three seconds intervals.
Fault in a switch serving doors, hood or trunk lid.	Flashing (instead of being on continuously) during delay period.

Some signals may differ between model variants for different countries.

SID message	Reason/action
SERVICE THEFT ALARM	Probably a faulty sensor or siren. Have the car checked by an authorized Saab dealer.
KEY NOT ACCEPTED	Fault in key transmitter or in ignition-switch receiver. Turn ignition switch to ON and press one of the buttons on the remote control. Start the engine. Have the car checked by an authorized Saab dealer.
REPLACE KEY BATTERY	Fit a new battery in the remote control.
DOOR ALARM ONLY	Window-glass sensor is disabled.
FULL THEFT ALARM	Window-glass sensor is included in circuit.
<ul style="list-style-type: none"> • REMOTE KEY • TRANSPONDR 	Turn the ignition key to position ON and then press the button for opening the trunk lid. SID displays the number of remote controls and transmitters (transponders) coded to the car.

This device complies with Part 15 of the FCC Rules. Operation is subject to the following two conditions: (1) this device may not cause harmful interference, and (2) must accept any interference received, including interference that may cause undesired operation.

Changes or modifications not expressly approved by the manufacturer could void the user's authority to operate the equipment.

Canada only:

This device complies with RSS-210 of Industry Canada. Operation is subject to the following two conditions: (1) this device may not cause interference, and (2) this device must accept any interference, including interference that may cause undesired operation of the device.

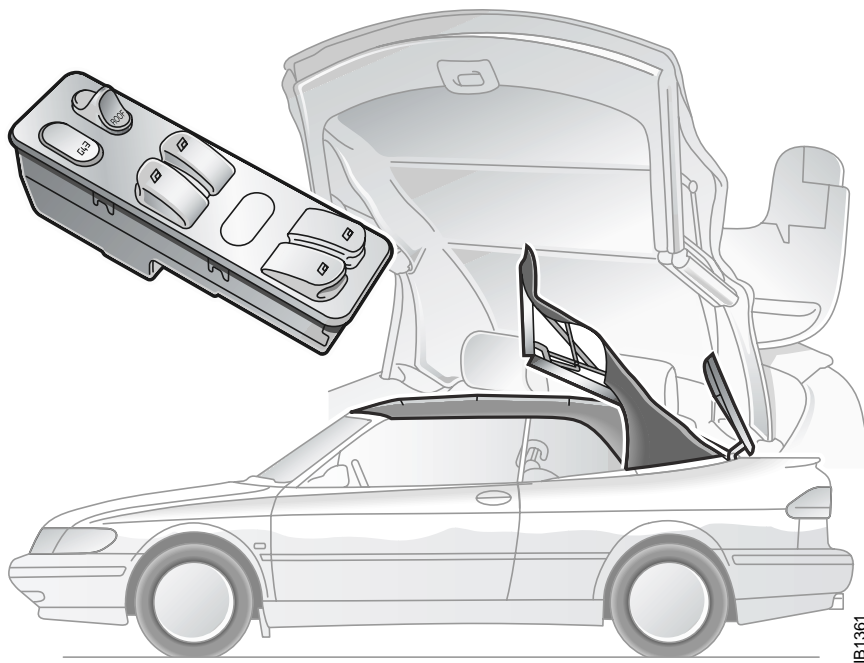

Convertible

General safety instructions	42
Folding the soft top	43
Raising the soft top	45
Manual raising of the soft top	46
Fault messages in SID.....	48
Central operation of the windows, 9-3 Convertible	49
Trunk, 9-3 Convertible	50
Cleaning the soft top, 9-3 Convertible	51
Interior lighting.....	52
Manually opening the fuel filler door	52

IB1361

Convertible

General safety instructions

- Never touch the hinges and struts of the soft top nor the upper beam of the windshield while operating the soft top.
- After raising the soft top, always check that it is properly secured to the top beam of the windshield with the soft top locking device before driving the car away. After folding it down you should check that the tonneau cover latches have engaged properly. Otherwise it may come loose while you are driving and cause injury.
- Do not operate the soft top with passengers in the rear seat or bystanders right next to the car. There is a risk of head injuries while the soft top is in motion.
- Remove child car seats and children before operating the soft top.
- Don't operate the soft top in temperatures below 23°F (-5°C).
- Note that certain automatic carwashes can do damage to fabric soft tops. This applies to carwashes that use mechanical feelers bearing against the body. We advise against washing a Saab 9-3 Convertible in automatic carwashes.
- Note that certain automatic car washes can cause water to leak in places that normally would not leak. Do not direct high pressure streams of water at the seals for the convertible top.
- Roof racks and ski holders must not be mounted on the soft top.
- Under no circumstances should anything be put into the storage space for the soft top (under the tonneau cover) since this could cause obstruction when the soft top is being folded away.
- See that no luggage is resting against the soft top stowage space since this could interfere with the raising and folding of the soft top.
- When the soft top is being operated, lowering or raising should be completed. Do not leave the soft top partially raised or lowered: after 20 seconds it will quickly "settle down" when the hydraulic pressure is automatically released.
- It is important that the telescopic locking handle is completely pushed in when the soft top is closed.
- Fold down any auxilliary mounted antenna before raising the top to avoid possible antenna or top damage (e.g., OnStar cellular antenna on windshield of Convertible)

Folding the soft top

Before operating the soft top, read through the section "General safety instructions" on page 42.

WARNING

- Do not touch the hinges or struts of the soft top during folding, because of the pinch hazard.
- Do not operate the soft top with passengers in the rear seat or bystanders right next to the car, because of the risk of head injuries.
- After lowering the top, make sure the soft top cover has locked properly.

NOTE

If you drive away while the soft top is being raised or lowered it will stop when the car exceeds 6 mph (10 km/h). The motion of the car and the resulting wind can seriously damage the components of the soft top system and may cause personal injury.

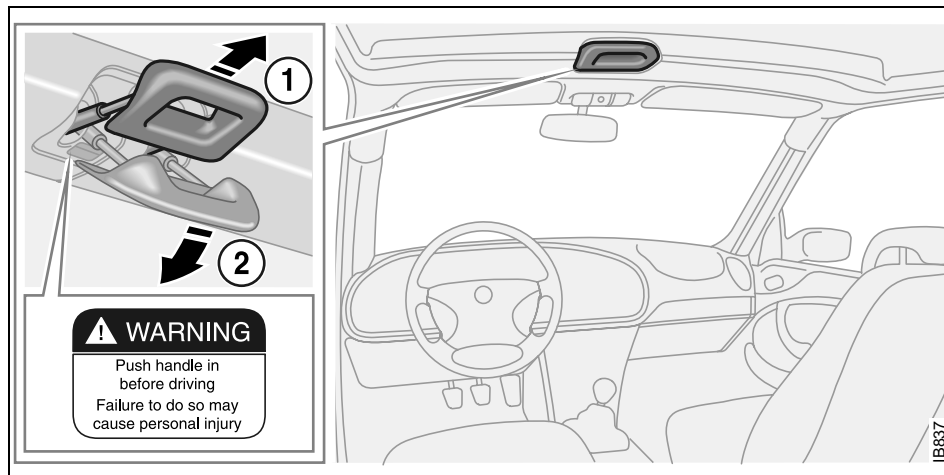

Locking handle

- 1 Pull the handle out
 - 2 Unfasten the hooks
- 1 Start the engine and let it idle.
 - 2 Release the locking handle to free the two hooks.
 - Pull the handle straight backwards.
 - Pull the handle down, releasing the hooks.
 - Raise the handle up.

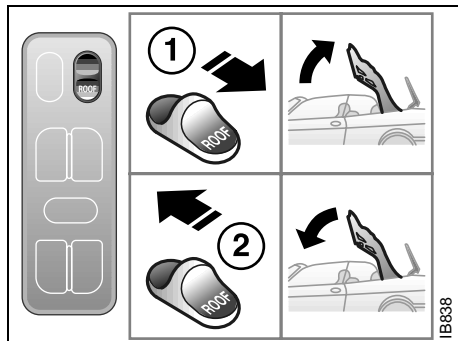

Switch for operating the soft top

- 1 Lowering
- 2 Raising

3 Slide the ROOF button backwards until the soft top is completely folded away, the tonneau cover is closed **and the SID has given an OK signal** (beep). Slide the ROOF button backwards a second time to lower the windows.

4 Check that there are no fault messages on the SID; see page 48.

NOTE

After folding the top down you should check that the front of the tonneau cover is locked at the front on both sides before driving away.

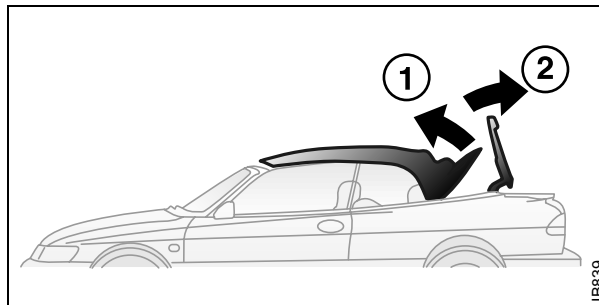

- 1 The rear window is raised.
- 2 The tonneau cover is opened.

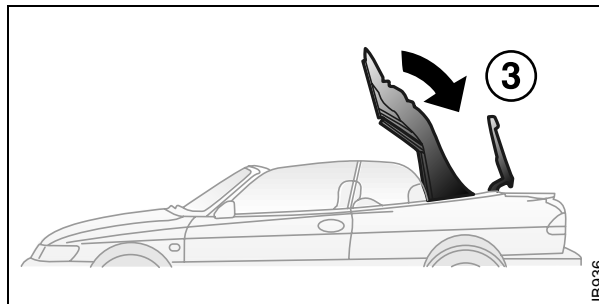

- 3 Roof and rear window are folded down.

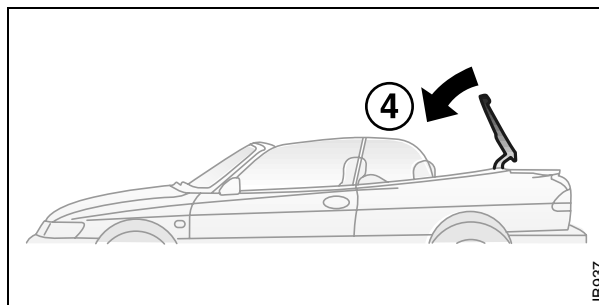

- 4 Tonneau cover is closed.

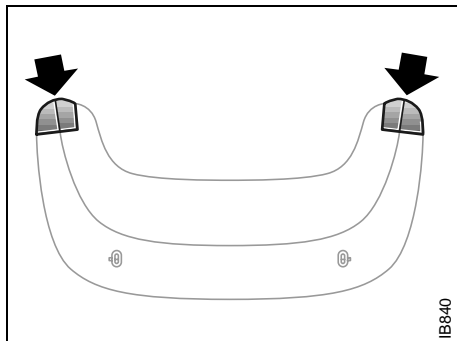

IBB40

The front-edge locking of the tonneau cover

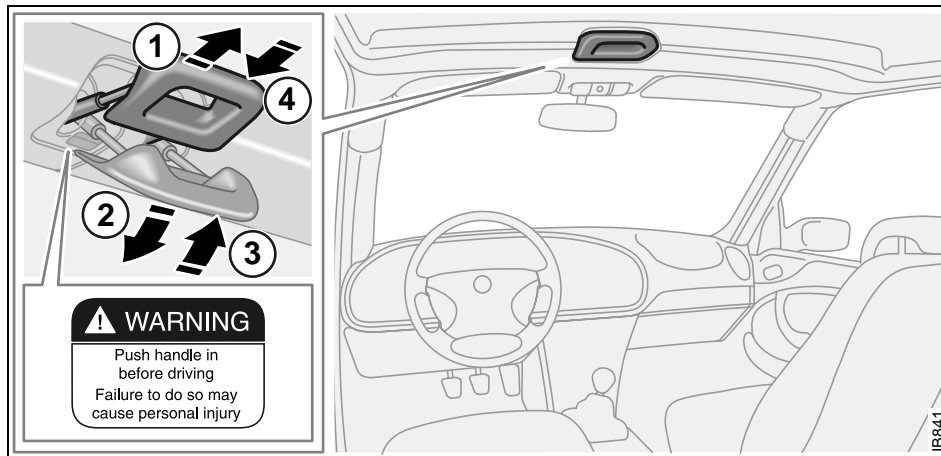

IBB41

Raising the soft top

WARNING

- Do not touch the hinges or struts of the soft top during raising the top, because of the danger of being injured.
- Do not operate the soft top with passengers in the rear seat or bystanders right next to the car, because of the risk of head injuries.

Locking handle

- 1 Pull the handle out and lift it
- 2 Push the handle in

- 1 Start the engine and let it idle.
- 2 Slide the ROOF button forward until the 5th bow is locked in the tonneau cover **and the SID has given an OK signal** (beep). The top must be locked within 20 seconds. If this is not done the soft top will lift an inch or two (a few centimetres). In this case, slide the ROOF button forward again until the SID gives an OK signal. Lock the soft top with the locking handle.

Note that all side windows will be automatically lowered an inch or two (a few centimetres) so as to protect the seal

strips when the soft top is raised.

The window operation is bypassed throughout the raising cycle to prevent the windows being raised.

- 3 Pull the front end of the soft top down with the aid of the closing handle and lock the soft top by rotating the locking handle up.
 - Pull the handle down.
 - Rotate the handle upwards, the soft top will be locked.
 - **Push the handle in.**

Check that the hooks have locked the soft top.

- 4 Raise the side windows by sliding the ROOF button forward a second time. Alternatively, use the central operating switch for the side windows.
- 5 Check that there are no fault messages on the SID; see page 48.

Manual raising of the soft top

WARNING

Manual operation of the soft top must be resorted to only **to raise** it in an emergency (e.g. in case of an electrical or hydraulic fault).

After manual raising the soft top must on no account be folded down manually, since this could cause damage to the soft top mechanism.

Points 6 to 8 are only valid if the soft top is operated manually when the soft top tonneau is locked.

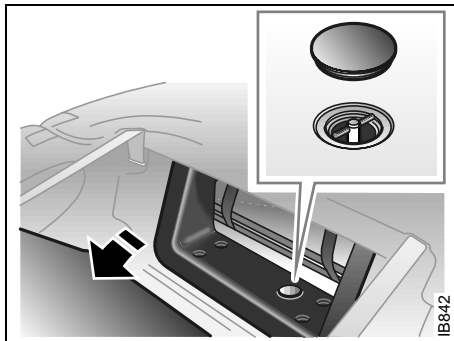

Valve for manual raising of the soft top

- 1 Tip the backrests of the rear seats forward.
- 2 Unlock the rear-seat backrest with the ignition key just outboard of the left rear headrest and tip it forward.
- 3 Remove the round rubber cover over the hydraulic valve.
- 4 Open the valve about half a turn.
- 5 Open the trunk lid.
- 6 Take out the wheel lug wrench.
- 7 In the soft top tonneau mechanism and inside the trunk lid lining on the right-hand side, is a hole into which the straight part of the tool is to be inserted; see the figure.

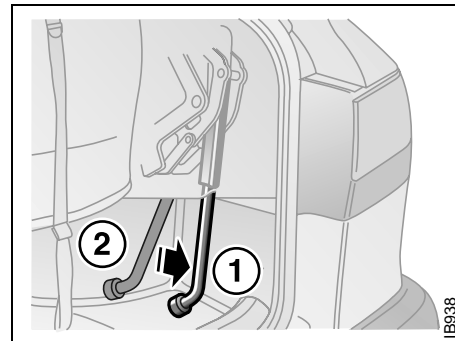

Tool fitted for manual unlocking (1) or locking (2) of the tonneau cover

- 8 Unlock the tonneau cover by pulling the tool backwards. The cover should lift half an inch or so (a centimetre or so). Remove the tool. Close the trunk lid.

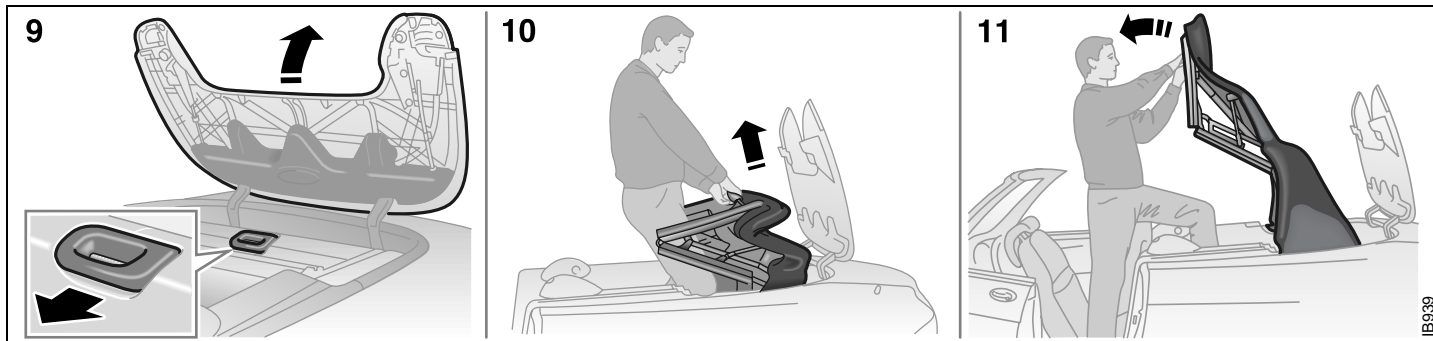

Manual raising of the soft top

- 9 (ill. 1) Stand at the side of the car and open the tonneau cover by grasping its black part.
- 10 (ill. 2) Get into the car and stand on the lowered backrest.

- 12 Climb down onto the floor and pull the soft top towards the windshield. Raise the 5th bow (rear window).
- 13 Stand at the side of the car and close the tonneau cover.

- 14 Tip down the 5th bow/rear window as far as possible.
Note: In manual raising it is not possible to completely secure the 5th bow in the recess of the tonneau cover.
- 15 Shut the valve of the hydraulic system, without making it too tight. Replace the cover over it. Raise the rear-seat backrest again. See that the safety belts don't get caught. Be sure the seat back locks in place on both sides.
- 16 Sit down in the front seat, open the handle and lock the soft top to the windshield beam. Make sure that the hooks engage in the beam.
- 17 In the trunk: replace the tool in the soft top mechanism and lock the soft top tonneau by pushing the tool forward until the stop point.
- 18 Take the tool out.

The soft top system must be checked and repaired by an authorized Saab dealer as quickly as possible.

 WARNING
<p>Do not touch the hinges and struts of the soft top during raising. Keep your hands clear of the upper beam of the windshield - this is a pinch hazard area. Do not operate the soft top with passengers in the rear seat or with bystanders right next to the car.</p>

NOTE
<p>Close the cover carefully so as not to damage the small flaps in the front.</p>

- 11 (ill. 3) Take hold of the handle and pull the soft top up.

Fault messages in SID

The following CHECK messages are included in the soft top system and can be displayed on the SID together with a beep.

SID displays	Cause	Action
CHECK SOFT TOP STORAGE	<ul style="list-style-type: none"> The soft top storage bag is hooked up. An item in the trunk under the soft top is obstructing the soft top. 	<ul style="list-style-type: none"> Unhook and lower the soft top storage bag, see page 50. Make sure that no item in the trunk is lying against the soft top storage.
CLOSE TRUNK LID	<ul style="list-style-type: none"> The raising or lowering of the soft top is obstructed because the trunk lid is not closed. 	<ul style="list-style-type: none"> Close the trunk lid so it is latched securely.
CHECK SOFT TOP LATCHES	<ul style="list-style-type: none"> The soft top is not latched to the top beam of the windshield. Somebody is trying to lower the soft top while it is still locked to the windshield beam. 	<ul style="list-style-type: none"> Lock the soft top with the locking handle, see page 45. Release the soft top with the locking handle, see page 43.
FINISH SOFT TOP MOTION	<ul style="list-style-type: none"> Raising or lowering was stopped before the cycle completed. 	<ul style="list-style-type: none"> Finish the soft top motion completely.
CHECK SOFT TOP COVER	<ul style="list-style-type: none"> The soft top cover is not being locked. The soft top cover doesn't open. 	<ul style="list-style-type: none"> Make sure that the valve for manual raising of the soft top is closed, see page 46. Try to slide the ROOF button backwards once more.
SOFT TOP FAILURE	<ul style="list-style-type: none"> Serious fault in soft top mechanism. 	<ul style="list-style-type: none"> Try to slide the ROOF button once more. BE VERY CAREFUL AND MAKE SURE THAT NOTHING IS OBSTRUCTING THE OPERATION OF THE SOFT TOP. Remove anything that can obstruct the operation of the soft top. Operate the soft top manually, see page 46.
CHECK SOFT TOP	<ul style="list-style-type: none"> Something is in the way and is obstructing the operation of the soft top by the electro- hydraulics. The soft top cover has not locked at the front on both sides. The 5th bow (rear window) has not locked to the soft top cover on both sides. 	<ul style="list-style-type: none"> Try to slide the ROOF button once more. BE VERY CAREFUL AND MAKE SURE THAT NOTHING IS OBSTRUCTING THE OPERATION OF THE SOFT TOP. Remove anything that can obstruct the operation of the soft top.

The following fuses should be checked if the soft top cannot be operated and no fault messages are shown by the SID:

- MAXI-fuse 5 in the engine bay, see page 188.
- 7, 14, 21 and 23 in the fuse panel on the end of the instrument panel, see page 189.

Central operation of the windows, 9-3 Convertible

On the center console is a switch (see illustration) for the simultaneous closing or opening of the four side windows.

Using the ROOF-button

When folding the soft top down, you can lower all windows by continuing to hold the ROOF button backwards after the soft top has been folded down.

When the soft top is being raised, all side windows are automatically lowered an inch or two (a few centimetres) to protect their seals. After the "beep" is heard, the hooks of the soft top have been secured to the windshield beam, hold the ROOF switch forward again and all 4 windows will close.

WARNING

Remember the risk of personal injury when raising the windows. Check that all persons travelling in the car have their head, hands and fingers away from the windows before raising them.

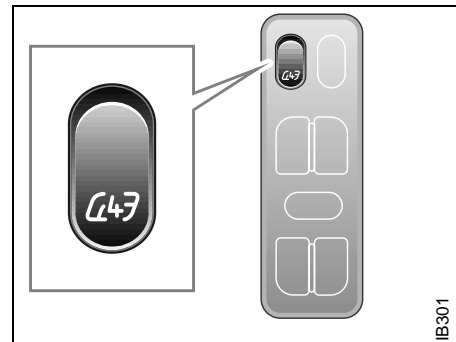

Switch for central operation of the windows, Convertible

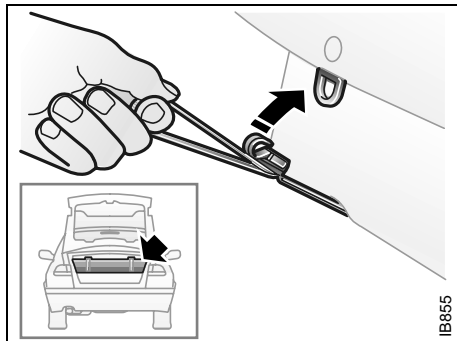

Suspending top bag

Trunk, 9-3 Convertible

Hooking up top storage bag

More space in the trunk can be obtained by lifting the top storage bag up by the straps under it and hooking them in the eyelets at the top of the bag.

The top storage bag can only be hooked up in this way when the top is raised. If you attempt to lower the top while the bag is hooked up, the SID will display the message "CHECK SOFT TOP STORAGE"; see page 48.

Trunk lid lock

Unlocking the trunk lid by using the remote trunk release button on the driver's door is possible only when the top is **fully** lowered or raised (note that the ignition must be in position ON when the top is lowered).

NOTE

If the trunk lid is opened by unlocking it with the key when the top is not fully raised or lowered, damage to the trunk lid and/or top system could result.

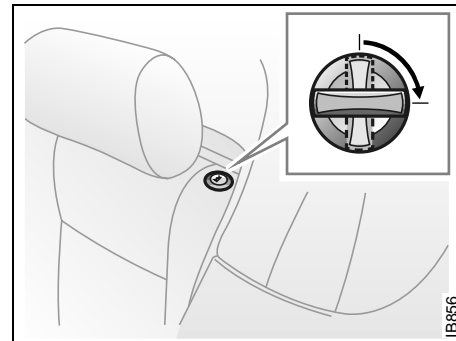

Lock for rear backrest cushion

Rear seat

The rear seat is intended for two passengers.

The two rear seat positions have three-point safety belts with inertia reels.

Lowering the rear seatback

To increase the load-carrying capacity of the car, the rear seatback can be folded forward. This will be easier if the front seats are not too far back.

- 1 Pass the rear safety belts under the black handles at both ends of the backrest. This prevents the safety belts from becoming caught when the seatback is raised again.
- 2 The seatback is fitted with a lock at the top near the left rear head restraint. Use the ignition key to unlock the entire backrest. Remove the key.
- 3 Lower the seatback. (In Canada, if using child seat top tether strap, detach from anchorage in trunk prior to lowering the seatback.)

NOTE

The trunk pass-through can only be used when the top is raised.

If you attempt to lower the top with the top storage bag suspended from the hooks or with a load pressing against the top storage bag, the SID will display the message "CHECK SOFT TOP STORAGE" (see page 48).

Trunk Pass-Through in the rear seatback for long, narrow loads

A trunk pass-through is provided in the rear seatback support so that long narrow objects can be carried. Before using this trunk pass-through, the rear seatback must be lowered.

Suspend the top storage bag by means of the hooks as previously described on page 50.

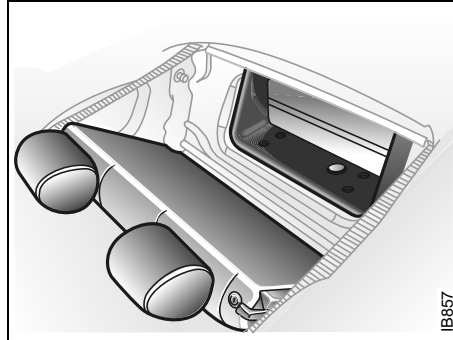

Pass through for long loads

Cleaning the soft top, 9-3 Convertible**NOTE**

- Note that some automatic car washes can damage a textile soft top. This applies to washes that have mechanical feelers in contact with the bodywork. We advise against washing a Saab 9-3 Convertible in automatic car washes.
- Park in the shade if possible. Long standing in strong sunlight can affect the color and material of the soft top.
- Never use strong bleaches or abrasive cleaning agents, since they can damage the textile soft top.
- Wash bird droppings off at once, since they can have a corrosive effect on the textile soft top and paint.
- During prolonged parking, especially winter storage, the soft top should be up to give optimum airing of the fabric.
- Do not wash the fabric soft-top with a high-pressure jet.
- Strong detergents and solvents can damage the flame retardant treatment of the soft top.

Use mild soap, lukewarm water and a sponge for washing.

Rinse the top thoroughly with plain water to get rid of all the soap. Flush the cleaning agent off the bodywork as well, since it can cause discoloration if it is left to dry on the paintwork.

If further cleaning is needed after soap and water have been used, a mild shampoo may be employed. First rinse the soft top, then use shampoo on the complete top and scrub with a small soft hand brush.

Add water as needed until the cleaning agent lathers. Use a rag or sponge to remove dirt, so as to avoid working it into the cloth. Thoroughly rinse the whole car with plain water and make sure that cleaning agents are not allowed to dry on the paintwork.

NOTE

After washing, the soft top must be given time to dry completely before being folded down. A wet or damp top that is folded down can be damaged by mold.

Cleaning the rear window

The rear window can be cleaned with a window cleaner or a mild soap solution and a soft, anti-static cloth.

Since the rear window is made of glass, when necessary, you can use an ice scraper on the outside. Never use a scraper on the inside!

Interior lighting

The front light is located on the front roof rail. The rear lighting consists of two lights built in to the side panels adjacent to the rear seat. The switch is on the center console between the front seats, see also page 121. Certain variants have a mirror and lighting built into the sun visors.

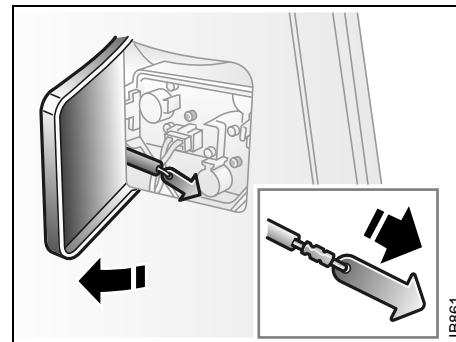

Wire for manual opening of fuel filler door (Convertible)

Manually opening the fuel filler door

Convertible

If the fuel filler door, controlled by the central lock, does not unlock take the following action:

Check fuse 25. If it is defective or blows again after changing, the locking motor can be detached from the flap by pulling a wire. The wire, marked with a yellow arrow at the end, is located in the trunk inside the opening in the upholstery in front of the right-hand rear light.

Instruments and controls

Warning and indicator lights	54
Instruments	59
Trip computer SID	62
Switches	71
Wipers and washers	74
Manual climate-control system.....	76
Automatic climate control (ACC).....	80



IB946

Main instrument panel

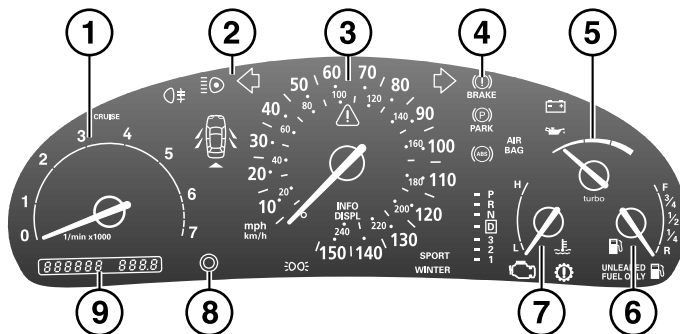

Main instrument panel

- | | |
|---|--|
| <ul style="list-style-type: none"> 1 Tachometer 2 Indicator and warning lights 3 Speedometer 4 Indicator and warning lights 5 Pressure gauge | <ul style="list-style-type: none"> 6 Fuel gauge (tank volume:
17 gallons (64 litres)) 7 Engine temperature gauge 8 Trip meter reset button 9 Odometer and trip meter |
|---|--|

IB1356

Warning and indicator lights

A number of warning and indicator lights will come on when the ignition is switched on prior to starting (see page 58). Under normal conditions, these should go out a few seconds after the engine has started.



Warning, oil pressure (engine oil)

This symbol comes on together with  if the oil pressure in the engine is too low. If the symbol flashes or comes on while you are driving, stop as soon as possible and where it is safe to do so, switch off the engine and check the engine oil level, see page 172.

NOTE

The car must not be driven under any circumstances when the warning lamp is on. Too low oil pressure will damage the engine.



Warning charging

This light comes on together with  if the battery is not charging. If it comes on while you are driving, stop the car as soon as possible and switch off the engine.

Check the alternator drive belt (see page 179). If the belt has broken, the engine may overheat (cooling system will not function properly), the belt is slack or broken, battery charging will be poor and engine cooling unsatisfactory.



Brake warning light

This light will come on together with  if there is insufficient brake fluid in the reservoir, see page 176.

If the ABS warning light is on at the same time, the ABS system may be inoperative because of a fault (see anti-lock brake warning).

WARNING

Never drive the car when these warning lights are on. Danger of brake failure!

Have the brake system checked at once by an authorized Saab dealer.



Parking brake warning light

The light will show when the parking brake is on (see page 151.)

If the car driven with the parking brake on,



 will also come on and a chime will sound.



The parking brake is mechanical and operates on the rear wheels.

WARNING

- Always apply the parking brake when parking
- Always apply the parking brake before removing the ignition key
- Do not apply the parking brake while the car is moving (see page 151)



Anti-lock brake warning

This light together with  and  indicates that a fault has occurred in the ABS system. Conventional braking without the ABS function will still be available.

For safety reasons, stop the car and check the level of the brake fluid (see page 176).

If the level is normal, depress the brake pedal firmly two or three times. Now check the level again. If the level is still normal, you may drive the car, with considerable caution, to the nearest authorized Saab dealer to have the brake system checked.

 **WARNING**

- If the ABS is inoperative, there is a danger of the rear wheels locking up on hard braking
- If the level of brake fluid in the reservoir is below the MIN mark, the car should be towed to an authorized Saab dealer



Airbag warning light

This light together with  will come on if a potentially serious fault has occurred in the airbag system.

 **WARNING**

- If the airbag readiness light stays on after you start your vehicle, it means the airbag system may not be working properly.
- The airbags in your vehicle may not inflate in a crash, or they could even inflate without a crash.
- To help avoid injury to yourself or others, have your vehicle serviced right away if the airbag readiness light stays on after you start your vehicle.

This light will come on for about three seconds when the ignition switch is turned to the Start or Drive position. It should go out after the engine has started.



Indicator, fuel

This light comes on when there is less than about 2.5 gallons (10 litre) of fuel left in the tank.

NOTE

If the car runs out of fuel, air can have been drawn in with the fuel, which, in turn, can cause the catalytic converter to be damaged by overheating.



Central warning light

This light comes on and a chime will sound if a fault has been detected in any system that is critical to safety. Any of the following can activate the central warning light and alarm:

- Airbag system.
- Low oil pressure in engine.
- Parking brake is on (when car is moving).
- Brake fluid level low.
- Fault detected in ABS system.
- Engine overheating.
- Alternator not charging properly.

The symbol and the chime will also sound if the ignition key is turned to the ON position but the engine is not started within 10 seconds.

CRUISE

Cruise Control indicator light

The symbol is lit when cruise control is active.



Engine malfunction (CHECK ENGINE)

WARNING

An illuminated CHECK ENGINE indicator light indicates a serious engine-related problem. While your car may be able to be driven with the CHECK ENGINE indicator light illuminated (limp-home mode), you are advised to have your car serviced at an authorized Saab dealer as soon as possible.

Continued driving without this problem being corrected might cause serious further damage to your car and create unsafe driving conditions. The operator should be prepared to take action if such unsafe conditions arise (e.g., apply the brakes, disengage transmission, turn off the ignition etc.).

This light indicates a malfunction in the fuel-injection or ignition system. The car may still be driven with care and with somewhat diminished performance.

SPORT

SPORT Mode Indicator

On cars with automatic transmission the indicator light comes on when you press the SPORT button on the gear-lever knob.

In SPORT mode, the transmission remains longer in the (D, 3, 2, 1) gears before upshifting.

Quit Sport mode by again depressing the SPORT button; see also page 147.

WINTER

WINTER Mode Indicator

On cars with automatic transmission the indicator light comes on when, in the D position, you press the WINTER button on the center console next to the gear selector.

When the car is in the Winter mode it starts in 3rd gear, which gives a better grip in slippery conditions by reducing the tendency to spin the wheels.

Quit Winter mode by again depressing the WINTER button; see also page 147.

INFO
DISPL**CHECK message
indicator**

This light indicates that there is a message in the SID. A chime will also sound (see page 63).

**Automatic transmission
fault indicator**

On a car with an automatic transmission, this warning symbol is illuminated if a fault has been detected in the transmission.

Switch the ignition off and on again to check if the fault persists.

Even if the fault persists, it is still possible in most cases to drive the car (see page 144).

Have the automatic transmission checked by an authorized Saab dealer as soon as possible.

NOTE

If the control module has actuated the Limp-home function for the automatic transmission, the car will remain in 4th gear when D is selected, making it very sluggish. To overcome this, move the selector lever to position 2.

When the indicator light is on, the car must not be driven with a trailer attached.

**Rear fog light Indicator**

This light shows when the rear fog light is on (see page 73).

The rear fog light is switched off automatically when the engine is switched off. When the fog light is next needed, it will have to be switched on manually again.

**High beam Indicator**

The symbol is lit when the high beam is on.

**Open door Indicator**

If a door has not been closed properly, the pictogram will indicate the door concerned (or trunk).

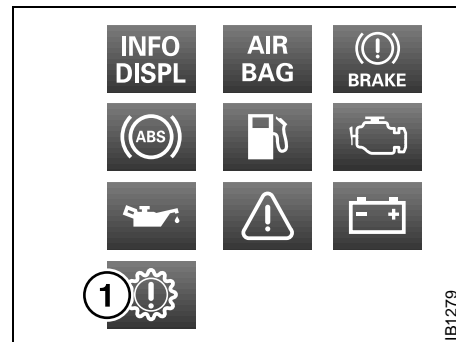

1 Cars with automatic transmission

**Autochecking of lights,
main instrument panel**

The above warning and indicator lights should come on when the ignition is switched on. They go out after about 3 seconds.

The following lamps light up until the engine starts, as long as no faults exist:

Central warning light .

Oil pressure warning light .

Charge warning light .

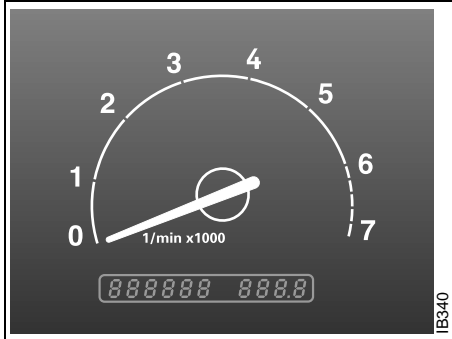

Instruments

Tachometer

The tachometer indicates the engine speed in thousands of revolutions per minute. The needle may be allowed to enter the broken red zone on the dial only for an instant.

A safety cut-out function (in the fuel system) prevents the engine speed exceeding approximately 6,200 rpm (2.0 Turbo) and 6,400 rpm (2.3 Turbo).

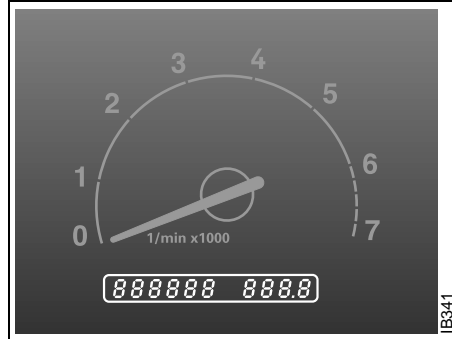

Odometer and trip meter

The odometer records the distance travelled in miles on U.S. vehicles and on Canadian vehicles the distance indicated is in kilometres, and the trip meter in miles and tenths (kilometres and tenths of kilometres on Canadian vehicles).

Reset button

The button is located close to the right of the odometer and trip meter in the main instrument panel.

The reset button has two functions, determined by whether the ignition is ON or OFF.

- When the ignition is ON, the button will reset the trip meter.
- When the ignition is OFF, the button will bring up the display for 20 seconds to allow the odometer and trip-meter readings to be viewed.

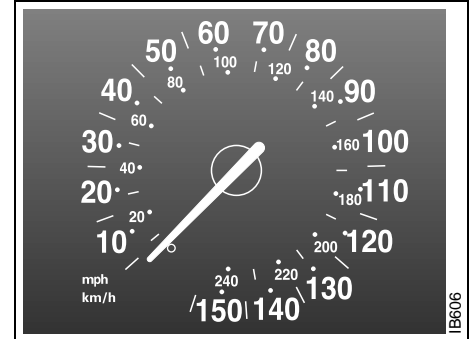

Speedometer (U.S. speedometer shown)

The speedometer receives signals from a wheel sensor in the ABS system.

If the NIGHT PANEL mode has been selected, the scale will be illuminated up to 87 mph (140 km/h). The remainder of the scale will be illuminated if the speed of the car exceeds 84 mph (135 km/h).

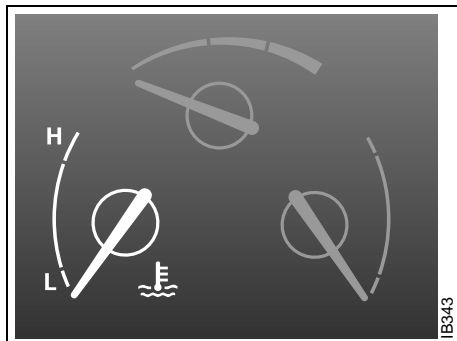

Temperature gauge

The temperature gauge shows the temperature of the coolant. The needle should be in the middle of the scale when the engine is at normal operating temperature.

If the needle enters the red zone, the  warning light will come on and an alarm chime will sound.

If the needle approaches the red zone, which can occur in very hot weather or when the engine is under a heavy load, drive in the highest gear possible, keep the engine revs low and avoid shifting down.

Check fuse 3 (radiator fan) in the fuse panel under the hood, see page 191.

If the needle repeatedly enters the red zone, stop the car as soon as it is safe to do so and check the coolant level by looking at the level visible through the plastic tank - do not remove the cap.

NOTE

If the needle, despite the above action, enters the red zone, stop the car immediately.

If the needle stays in the red zone, stop the engine.

If the coolant level falls below the MIN mark, the SID will display the message "FILL COOLANT FLUID".

WARNING

Never open the coolant expansion tank cap when the engine is hot. It contains hot coolant under pressure. Failure to heed this warning may result in personal injury.

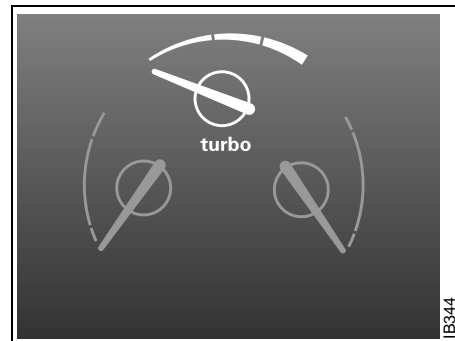

Pressure gauge

The pressure gauge indicates the pressure in the induction manifold. Under low load and while the engine is braking there will be vacuum in the induction manifold. The needle of the pressure gauge will then move within the white zone. At higher engine speeds and higher loads, the turbo-compressor produces an overpressure in the induction manifold. The needle will then enter the orange zone. Normally the needle should not enter the red zone, since a monitoring system sets limits to the charging pressure and protects the engine.

Under certain barometric conditions the needle may enter the first part of the red zone without necessarily indicating that a fault has arisen.

If the needle repeatedly enters the red zone and the engine at the same time loses power, because the monitoring system is holding the charging pressure down, you should contact an authorized Saab dealer.

If the speed exceeds 143 mph (230 km/h), the increase in speed will be limited by the lowering of the boost pressure. The pressure gauge then moves towards the middle of the orange zone, indicating reduced engine output and thus reduces the speed of the car as well.

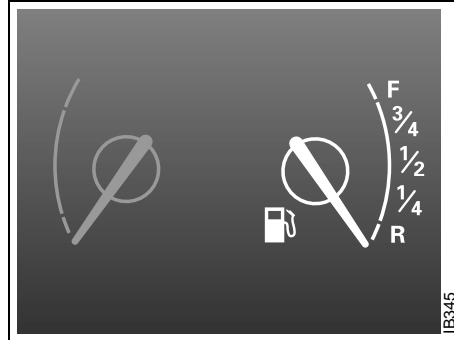

Fuel gauge

The fuel-tank capacity is 17.0 gal. (64 liters). The fuel gauge shows the amount of fuel left in the tank. When this is down to about 2.5 gal. (10 liters), a warning light on the main instrument panel will come on (see page 56).

Use the Saab Information display (SID) to check the approximate distance that can be travelled on the remaining fuel (see page 62).

Refueling; see page 138.

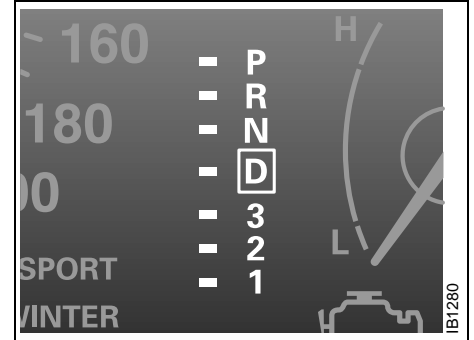

Gear selector indication (cars with automatic transmission)

An indicator showing which gear is selected is situated in the main instrument panel.

Trip computer SID (Saab Information Display)

The car is equipped with SID (Saab Information Display). This instrument contains a varying number of functions depending on the standard of equipment and the model variant.

SID 2 displays CHECK messages and has four trip-computer functions.

SID 3 displays CHECK messages and has eight trip-computer functions; see page 65.

WARNING

It is strongly recommended that the SID settings be changed only when the car is stationary. The driver's attention can otherwise easily be distracted from the road.



SID 2

SID 2

Selecting the function

Use the  and  buttons to scroll through the following functions:

TEMP	Outdoor temperature and Date.
D.T.E.	Estimated range (distance to empty fuel tank).
FUEL Ø	Average fuel consumption since function last reset.
SPD Ø	Average speed since function last reset.

Outside temperature (warning of slippery conditions)

Regardless of what function you have selected, SID automatically switches to the outside-temperature function when this temperature is between 26° and 38°F (-3° and +3°C), and also when temperature has been selected and it has been outside the range from 21° to 43°F (-6°C to +6°C) and again enters the range between 26° and 38°F (-3°C and +3°C).

WARNING

Remember that roads can be icy even at temperatures of above 38°F (+3°C), especially on bridges and stretches of road that are sheltered from the sun.

Resetting values

Resetting is accomplished by depressing the CLEAR button for at least 4 seconds. The following values will be reset:

- Distance To Empty (DTE).
- Average fuel consumption.
- Average speed.

CHECK messages

When the engine is started, CHECKING will appear on the display for about four seconds, while the SID checks are being performed.

When a CHECK message is generated while the car is being driven, a chime will sound, INFO DISPL will illuminate on the main instrument panel, and the message will appear on the SID. The number of messages that can be displayed by the SID varies with the specification of the car.

If more than one CHECK message has been generated, the + symbol will appear to the left of the text on the display. The messages appear in order of priority.

If a new fault occurs while another message is being displayed, the message relating to the new one will appear for 10 seconds, after which the display will return to the earlier one.

Press CLEAR once to acknowledge a message, whereupon it will be cleared from the display. It will not be displayed again before the ignition has been switched off and then on again.

The following CHECK messages may be displayed:

Display shows:	See page
TEST BRAKE LIGHTS ¹⁾	183
BRAKE LIGHT FAILURE	183
FRONT LIGHT FAILURE	181
REAR LIGHT FAILURE	183
FOG LIGHT FAILURE	183
WASHER FLUID LEVEL LOW	180
FILL COOLANT FLUID	174
TIGHTEN FUEL FILLER CAP	138
KEY NOT ACCEPTED	39
REPLACE KEY BATTERY	39
SERVICE THEFT ALARM	39
TRANSMISSION OVERHEATING	144
TIME FOR SERVICE ²⁾	212

1 This message cannot be removed by pressing CLEAR. Press the brake pedal to clear.

2 This message will be displayed approximately 600 miles (1,000 km) before the next scheduled service is due, or when 365 days have elapsed since the last service. The message should be cleared at the time of that service (see the Saab Warranties & Service Record Booklet).

If you have carried out the service yourself, you can clear the message by pressing CLEAR once. Reset by pressing CLEAR for at least eight seconds, until "SERVICE" appears on the display and a chime sounds.

Night Panel

To improve night-driving conditions inside the car, the Night Panel mode can be selected. In this mode, the amount of information displayed is reduced, and only the most important instruments and displays will be illuminated.

When the Night Panel button is pressed, only the speedometer will be illuminated (up to the 87 mph or 140-km/h graduation), all the other instruments illumination will be extinguished and their needles moved to zero. Both the SID and the ACC displays will be extinguished and the backlighting for switches and other controls will be dimmed. Note: All indicator and warning lights, together with the display of CHECK messages, will operate as normal.

The following conditions will wake up the respective displays in the Night-Panel mode:

- Adjusting of the Audio System, SID or ACC (display comes on for ten seconds).
- CHECK message generated in the SID.
- High engine revs cause the rev counter to be illuminated until the engine speed has fallen again.
- If the quantity of fuel remaining falls below 4 gallons (15 liters), the fuel gauge will be illuminated.
- If the engine temperature rises above normal, the temperature gauge will be illuminated.

- If the speed of the car exceeds 84 mph (135 km/h), the entire speedometer will be illuminated.
- In cars with automatic transmission, if the selector lever is moved from D to position 3, 2 or 1, the selector indication on the main instrument panel will be illuminated.

To restore the displays and lighting to the normal mode, press the Night-Panel button.

Setting the date

- 1 Use or to select TEMP/DATE.
- 2 Press the CLEAR button and for at least one second (year starts to flash and a chime sounds).
- 3 Set the year using or .
- 4 Touch CLEAR.
- 5 Set the month in the same way.
- 6 Touch CLEAR.
- 7 Set the day in the same way.
- 8 Press CLEAR to save the date setting.

Units and language versions

The SID has four sets of units:

METRIC	IMP. 1	IMP. 2	US
km	miles	miles	miles
km/h	mph	mph	mph
litres	gallons	gallons	US gallons
°C	°F	°C	°F
24 hours	12 hours	12 hours	12 hours

CHECK messages can be displayed in six language options: English, Swedish, German, French, Italian and Spanish.

Selecting units and language

- 1 Depress the CLEAR button and at the same time for 4 seconds until an audible signal sounds.
- 2 Select the required units with or .
- 3 Briefly depress the CLEAR button.
- 4 Press or to select the required language.
- 5 Briefly depress the CLEAR button.



IB964

Clock

Set the clock by using the two buttons under the digital clock on the left of the display.

Programming features, see page 231.

SID 3 (SCC)

! WARNING

It is strongly recommended that the SID settings be changed only when the car is stationary. The driver's attention can otherwise easily be distracted from the road.

Selecting the function

Use the  button to scroll through the following functions:

- DIST Distance to destination / Trip meter.
- ARRIV Estimated time of arrival.
- ALARM Alarm function.
- SPD W Speed warning (chime).

Use the  button to scroll through the following functions:

- TEMP Outdoor temperature and Date.
- D.T.E. Estimated range (distance to empty fuel tank).
- FUEL Ø Average fuel consumption since function last reset.
- SPD Ø Average speed since function last reset.



SID 3 (SCC, Saab Car Computer)

Outside temperature (Frost warning)





Regardless of what function you have selected, SID automatically switches to the outside-temperature function when the temperature is between 26° and 38°F (-3° and +3°C), and also when temperature is selected and it has been outside the range from 21° to 43°F (-6°C to +6°C) and again enters the range between 26° and 38°F (-3°C and +3°C).

! WARNING



Remember that roads can be icy even at temperatures of above 38°F (+3°C), especially on bridges and stretches of road that are sheltered from the sun.

Entering values for the functions

Values can be entered for the following functions: SPD Ø (SPEED AVERAGE), DIST, ARRIV, ALARM and SPD W.

- 1 Select the desired function using  or .
- 2 Press the SET button for at least one second (figures start to flash and a chime sounds).
- 3 Use  or  to increase or decrease the value (press CLR to reset).
- 4 Press SET to record the value.

Setting the date

- 1 Use  to select TEMP/DATE.
- 2 Press the SET button for at least one second (year starts to flash and a chime sounds).
- 3 Set the year using  or .
- 4 Touch SET.
- 5 Set the month in the same way.
- 6 Touch SET.
- 7 Set the day in the same way.
- 8 Press SET to save the date setting.

Turning the Alarm and Speed warning on or off

- 1 Select the Alarm or Speed-warning function.
- 2 Press SET to turn on the function. Press CLR to turn off the function.

When either function is on, an asterisk * will be visible on the far right of the display. The function will be visible even if another function has been selected.



The Alarm and Speed-warning settings will not be cancelled when the engine is switched off.

When the Alarm has been set to come on at a specified time, it will only be activated once – it will not come on at the same time every day. Press SET to turn it on again. The Alarm will continue to beep for one minute if not switched off.

Calculation of arrival time and average speed

The settings must be made before the journey is started.

Calculation of arrival time:

- 1 Select DIST using the  button.
- 2 Hold SET until display starts flashing.
- 3 Set the destination distance using  or  .
- 4 Press SET to store settings.

When ARRIV is selected during the journey, the arrival time based on the average speed over the past 20 minutes will be displayed. Press DIST and the distance remaining to the destination will be displayed in the same way.

After the distance to destination has decreased to zero, the DIST will function as a trip meter (see "Using DIST as a trip meter"). The starting value for the trip meter will be the last distance set in the DIST function.

Example: The DIST setting was 100 miles. Once 100 miles (160 km) has been covered, the DIST will start to function as a trip meter, the initial reading of which will be 100 miles (160 km).

Using DIST as a trip meter

If no value has been set for the DIST function, DIST will now function as a trip meter (indicated by an arrow on the far right of the display).







Press CLR to reset the trip meter.

Under 1000 miles the distance will be shown in increments of 0.1 miles, there-after, the reading will change in increments of 1.0 miles.

Metric units: for just under a kilometer, the distance will be shown in increments of 10 meters, there-after, the reading will change in increments of 100 meters.







When DIST is functioning as a trip meter, the ARRIV function will display the current time.

To calculate the arrival time if a specified average speed is maintained

- 1 Select DIST using the  button.
- 2 Hold the SET button for two seconds.
- 3 Set the distance to be covered using  or .
- 4 Press SET to store settings.
- 5 Press  to select SPD Ø.
- 6 Hold the SET button for two seconds.
- 7 Set the average speed you intend to drive at using  or .
- 8 Press SET to display the estimated arrival time.

At the beginning of a journey, the SPD Ø and ARRIV functions will display current values. If values are set during the journey, the new values will be displayed after a delay of about 10 seconds.

Calculating the requisite average speed:

- 1 Press  to select DIST.
- 2 Hold the SET button for two seconds.
- 3 Set the distance to be covered using  or .
- 4 Press SET to store settings.
- 5 Press  to select ARRIV.
- 6 Hold the SET button for two seconds.
- 7 Set the desired arrival time using  or .
- 8 Press SET to display the average speed you need to maintain to arrive at the desired time.

At the beginning of a journey, the SPD Ø and ARRIV functions will display current values. If values are set during the journey, the new values will be displayed after a delay of about 10 seconds.

Resetting values

To reset the values, press CLR for at least four seconds.

The following functions will be reset simultaneously:

- Estimated range on remaining fuel (function based on a fuel consumption of 28 mpg)
- Average fuel consumption
- Average speed
- Arrival time (function based on current speed)

Programmed values for DIST, ALARM and SPD W will not be reset (see the respective function).

CHECK messages

When the engine is started, CHECKING will appear on the display for about four seconds, while the SID checks are being performed.

When a CHECK message is generated while the car is being driven, a chime will sound, INFO DISPL will illuminate on the main instrument panel, and the message will appear on the SID. The number of messages that can be displayed by the SID varies with the specification of the car.

If more than one CHECK message has been generated, the + symbol will appear to the left of the text on the display. The messages appear in order of priority.

If a new fault occurs while another message is being displayed, the message relating to the new one will appear for 10 seconds, after which the display will return to the earlier one.

Press CLR once to acknowledge a message, whereupon it will be cleared from the display. It will not be displayed again before the ignition has been switched off and then on again.

The following CHECK messages may be displayed:

Display shows:	See page
TEST BRAKE LIGHTS ¹⁾	183
BRAKE LIGHT FAILURE	183
FRONT LIGHT FAILURE	181
REAR LIGHT FAILURE	183
FOG LIGHT FAILURE	184
WASHER FLUID LEVEL LOW	180
TIGHTEN FUEL FILLER CAP	138
FILL COOLANT FLUID	174
KEY NOT ACCEPTED	39
REPLACE KEY BATTERY	39
SERVICE THEFT ALARM	39
TRANSMISSION OVERHEATING	144
TIME FOR SERVICE ²⁾	212

1 This message cannot be removed by pressing CLR. Press the brake pedal to clear.

2 This message will be displayed approximately 600 miles (1,000 km) before the next scheduled service is due, or when 365 days have elapsed since the last service. The message should be cleared at the time of that service (see the Saab Warranties & Service Record Booklet).

If you have carried out the service yourself, you can clear the message by pressing CLR once. Reset by pressing CLR for at least eight seconds, until "SERVICE" appears on the display and a chime sounds.

Night panel

To improve night-driving conditions inside the car, the Night Panel mode can be selected. In this mode, the amount of information displayed is reduced, and only the most important instruments and displays will be illuminated.

When the Night Panel button is pressed, only the speedometer will be illuminated (up to the 87-mph or 140-km/h graduation), all the other instruments illumination will be extinguished and their needles moved to zero. Both the SID and the ACC displays will be extinguished and the backlighting for switches and other controls will be dimmed. Note: All indicator and warning lights, together with the display of CHECK messages, will operate as normal.

The following conditions will wake up the respective displays in the Night-Panel mode:

- Setting of the Audio System, SID or ACC (display comes on for ten seconds).
- CHECK message generated in the SID.
- High engine revs cause the rev counter to be illuminated until the engine speed has fallen again.
- If the quantity of fuel remaining falls below 4 gallons (15 liters), the fuel gauge will be illuminated.
- If the engine temperature rises above normal, the temperature gauge will be illuminated.
- If the speed of the car exceeds 84 mph (135 km/h), the entire speedometer will be illuminated.
- In cars with automatic transmission, if the selector lever is moved from D to position 3, 2 or 1, the selector indication on the main instrument panel will be illuminated.

To restore the displays and lighting to the normal mode, press the Night-Panel button.





Units and language versions

The SID has four sets of units:

METRIC	IMP. 1	IMP. 2	US
km	miles	miles	miles
km/h	mph	mph	mph
litres	gallons	gallons	US gallons
°C	°F	°C	°F
24 hours	12 hours	12 hours	12 hours

CHECK messages can be displayed in six language options: English, Swedish, German, French, Italian and Spanish.

Selecting units and language

- 1 Press the CLR and SET buttons at the same time for 4 seconds until an audible signal sounds.
- 2 Press  or  to select the required units.
- 3 Touch SET.
- 4 Press  or  to select the required language.
- 5 Touch SET.



Clock

Set the clock by means of the two small buttons under the digital clock on the left of the display.

Programming features, see page 231.

Switches



Daytime running lights

The parking lights and daytime running lights come on automatically when the ignition switch is in the ON position.

Note to owners in the U.S.: If you do not want Daytime Running Lights, this feature can be disconnected: switch off the engine and remove fuse No. 15 (see page 189).

Note to owners in Canada: Daytime Running Lights must not be disconnected as they are a Canadian Federal legal requirement.



Parking lights

The parking lights can be switched on regardless of the position of the ignition switch. Do not use parking lights when driving.

Note:

The lighting switch must be in parking or headlight position to operate the rear fog light (see page 73).

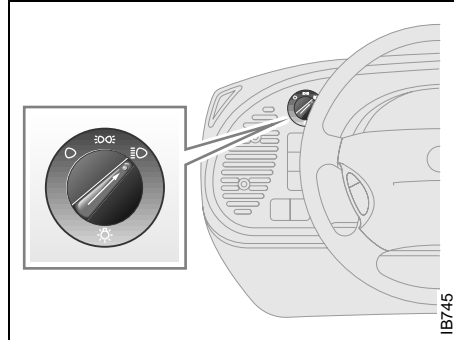

Light switches



Headlights

The headlights come on when the ignition switch is in the OFF, ON or START positions. Note that they go off again when the ignition switch is turned to LOCK.

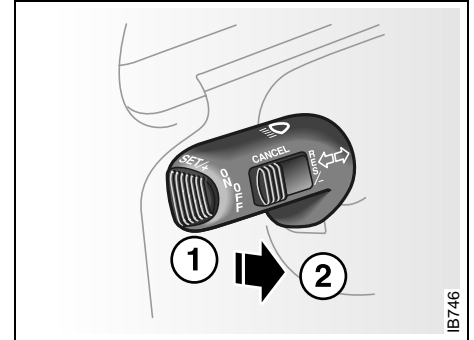

- 1 Headlight flasher
- 2 High/low beam

High/low beam

To switch from high to low beam, move the control stalk towards the steering wheel to position 2.

Headlight flasher

To flash your headlights, move the control stalk towards the steering wheel to position 1. The high beam will remain on until you release the switch.

Courtesy Headlamp Feature

A delay function allows the headlights to remain on low beam for about 30 seconds after the driver's door has been closed.

To activate this function, switch off the ignition, remove the key, open the driver's door and pull the high/low beam control stalk towards the steering wheel like you are flashing the high beam, see page 71. The low beam headlights will now come on immediately after the driver's door has been closed and will remain on for about 30 seconds.

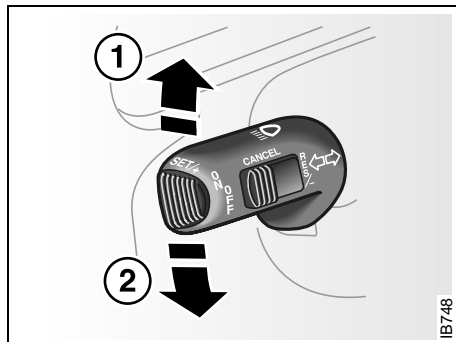

Turn signal & lane change indicators

- 1 Right indicators
- 2 Left indicators

Turn signal & lane change indicators

To switch on the indicators, move the stalk up or down.

The stalk has fixed positions for indicating a right or left turn, and the indicators are cancelled automatically (stalk returns to off position) after most turns.

The stalk also has an intermediate, spring-loaded position that is useful for signalling when changing lanes or passing.

The respective indicator lights on the instrument panel flash at the same frequency as the indicators

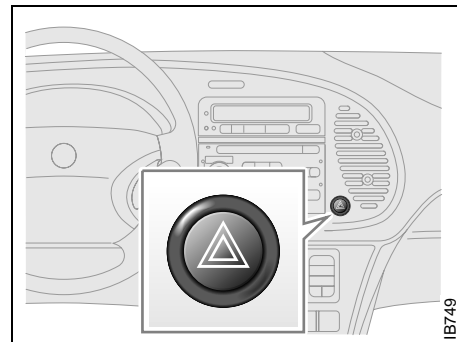

Hazard warning lights

When this button is pressed, all the turn signal & lane change indicators and a symbol in the button flash simultaneously. If the ignition is on, both indicator lights on the instrument panel will also flash.

If the hazard warning lights are left on for some time, the flasher frequency will be reduced to save the battery.

Hazard warning lights should only be used if, because of an accident or breakdown, the car constitutes a hazard to other road users.

! WARNING

Switch on the hazard flashers if the car has to be left at the roadside on account of an accident, engine trouble or a flat tire.

If you carry a warning triangle or flares, they should be set up along side of the road 300 ft. (100 m) behind your vehicle. If the car is not clearly visible (e.g. over the brow of a hill or bridge), place the triangle/flare even further back.

Back-Up

The back-up lights come on automatically when reverse gear is engaged or selected with the ignition switched on.

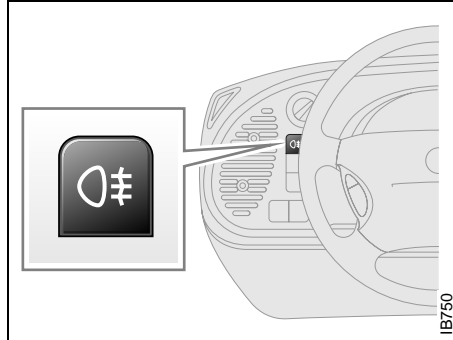

Rear fog light

Press the button to switch on the rear fog light, which will only come on if the headlights or front fog lights are on. The rear fog light will go off automatically when the engine is switched off. When the fog light is next needed, it will have to be switched on manually again. Your Saab is equipped with one rear fog light and this is located on the driver's side in the rear tail-light housing.

Make sure you are familiar with the applicable provincial/state law regarding the use of rear fog lights.

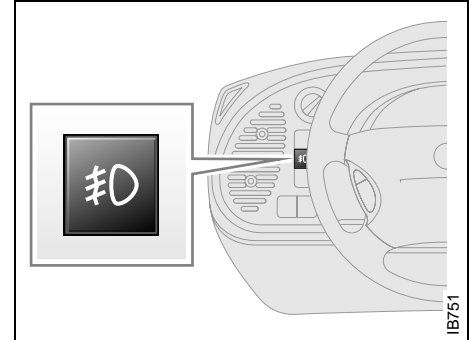

Front fog lights

Press the button to switch on the fog lights fitted in the front spoiler. These should be used in poor visibility. They will only operate on low beam and switch off automatically on high beam.

Make sure you are familiar with the applicable provincial/state law regarding the use of fog lights.

! WARNING

In poor visibility, avoid following the tail lights of the vehicle in front. If the vehicle stops suddenly, you may be unable to avoid a collision and therefore risk injury to yourself and others.

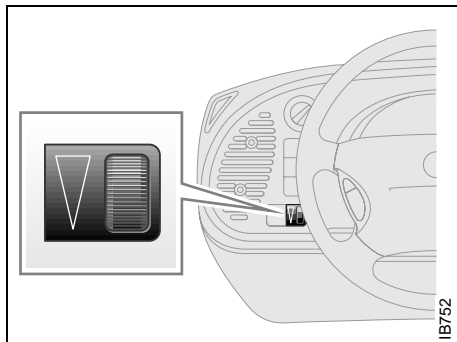

Instrument lighting

The brightness of the instrument lighting can be varied by means of the dimmer switch adjacent to the headlight switch, the ignition switch shall be in position ON. (See also Night panel on page 69).

In daylight or other equally bright light, the instrument and switch illumination is automatically extinguished.

Wipers and washers

Windshield wipers

The delay of the intermittent operation can be adjusted to between 2 and 15 seconds.

Moving the control stalk to the spring-loaded position between 0 and 2 will produce a single sweep of the wipers.

Washers

When the washers are operated the wipers will make 3, 4 or 5 sweeps depending on how long the washers were in action. If the speed of the car is less than 12 mph (20 km/h) the wipers will make an additional sweep after about 9 seconds.

The headlights are washed and wiped automatically whenever you use the windshield washers. They cannot be operated independently of the windshield washers.

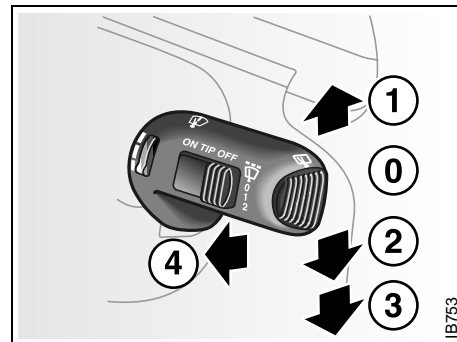

- 0 OFF
- 1 Windshield wipers: intermittent operation. The delay can be adjusted to between 2 and 15 seconds
- 2 Windshield wipers: low speed
- 3 Windshield wipers: high speed
- 4 Washing the windshield and cleaning the headlights

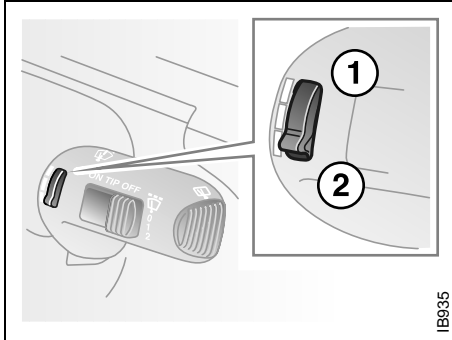



IB935

Control for setting wiper delay

- 1 Long delay
- 2 Short delay

Rear-window wiper

Rear-window washing and wiping are carried out using the same stalk switch as for washing and wiping the windshield and headlights.

This stalk has two additional switches, ON/OFF  and .

The ON position gives intermittent wiping.

The  position gives washing and wiping. After a few sweeps the wiper stops, or reverts to intermittent wiping if this has been selected. When washing/wiping of the rear window ends, the wiper makes a single sweep after about 15 seconds to wipe away any remaining washer fluid.

Moving the control stalk to the spring-loaded position between OFF and ON will produce a single sweep of the wipers.

Intermittent wiping of the rear window is done when reverse gear is selected, if the wipers are in position 1, 2 or 3, see page 74.

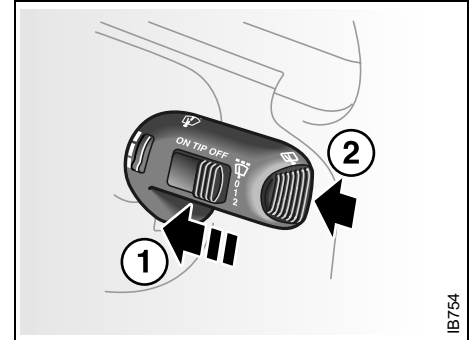

IB754

Rear-window wiper

- 1 Intermittent wiping
- 2 Washing

Manual climate-control system

The air is drawn in through an intake at the bottom edge of the windshield. It passes through an efficient filter before being routed through the climate-control system and into the cabin. The cabin discharge vent is located on the right behind the rear bumper. The air discharge vents should be kept free of snow and ice in the winter.



Fan

The rate of air flow inside the car is controlled by means of the fan switch.

Temperature control

The temperature of the incoming air can be steplessly varied using the temperature control.

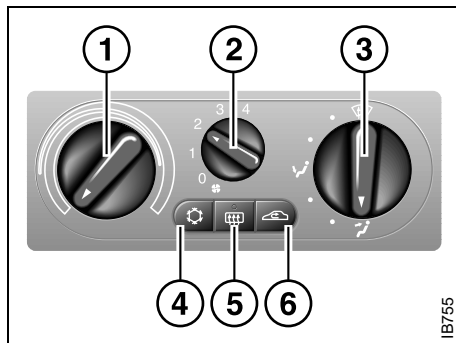

IB755

Control panel: manual system

- 1 Temperature
- 2 Fan speed
- 3 Air distribution
- 4 Air conditioning (A/C)
- 5 Rear-window heating
- 6 Recirculation

Air distribution

The air distribution control is used to direct the flow of air to the defroster, dash and floor vents.

The control permits settings intermediately between the three main settings so that the available air can be apportioned between the floor and the windshield (defroster) or between the floor and the panel.

To counter cold drafts from the front side windows when the control has been set to defroster or floor, a small flow of air issues from the dash vents.

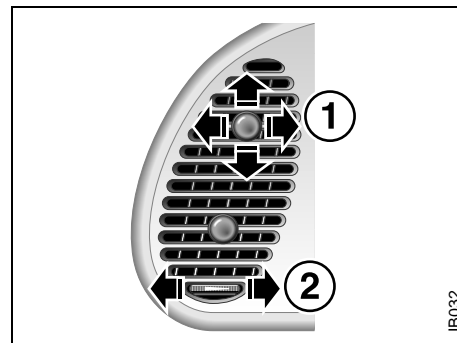

IB032

Dash vent



- 1 Adjusting the direction of the air flow.
- 2 Adjusting the air flow

The dash vents swivel universally, so that the air can be directed as desired.

The flow of air through the dash vents can be adjusted for each vent by means of the adjacent control.

Air to the rear side windows is supplied by the floor ducts. To demist these windows you should therefore select a defroster/floor combination.

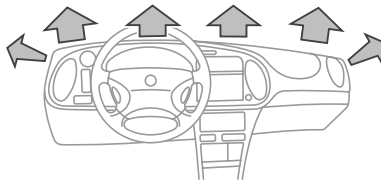
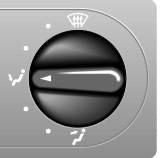
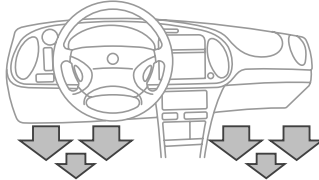
If the windows are thoroughly cleaned it is much easier to keep them free of mist.

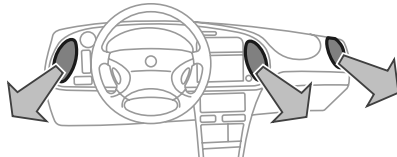
 <p>Defroster</p>	
 <p>Floor</p>	 <p>incl. rear side windows</p>
 <p>Panel</p>	 <p>incl. rear center vent</p>

As the winter comfort setting we recommend that the distribution knob be turned two steps to the left from the Defroster position.

Settings for various weather conditions

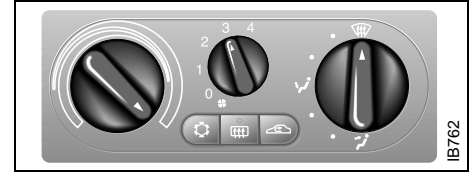

Winter - defroster

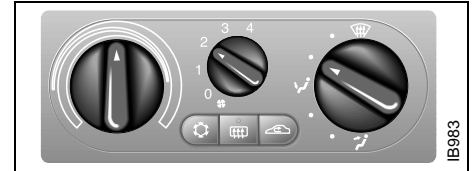

Winter - comfort

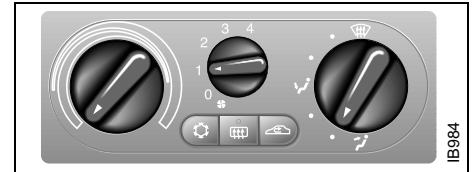

Summer - cloudy

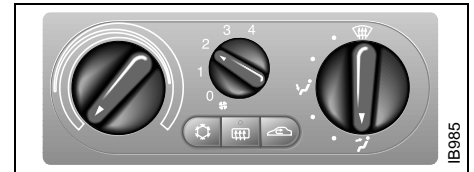

Summer - sunny

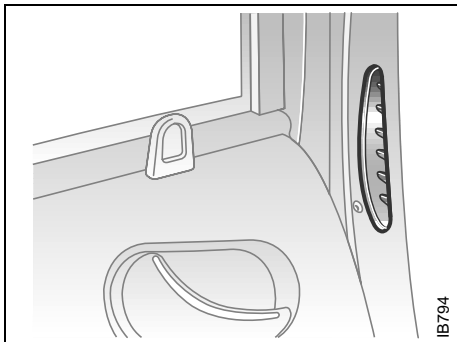

Air vent at rear side window



Air conditioning (A/C)

The air conditioning is combined with the conventional climate-control system and is switched on by pressing the  button, provided that the fan control is in position 1-4.

The incoming air is treated in three stages: first it passes through a filter; it is then dehumidified and cooled and, finally, if required, heated.

The air conditioning can be used at outdoor temperatures down to 32°F (0°C).

Condensation water

When the A/C compressor is on, the incoming air is dehumidified. The resulting condensation water is drained away through an outlet under the car.

It is therefore perfectly normal for water to be seen dripping from this outlet when the car is parked. The warmer the ambient air and the higher the humidity, the more condensation will form.



Recirculation

When the  button is depressed the regular air intake will be closed. In this position, the air inside the cabin is recirculated.

Use recirculation when you want rapid cooling, at extremely high air temperatures. Switch the air conditioning (A/C) on first.

Recirculation can be useful to activate manually to prevent unpleasant smells being drawn into the car from outside.

Note that recirculation should not be used when the outside temperature is lower than 50°F (+10°C) except briefly, e.g. to avoid unpleasant air from entering the car. Prolonged use of recirculation could cause the windows to mist or ice up.



Electrically heated rear window/external mirrors

The button is located on the climate-control panel. An LED in the button is lit as long as heating is on.

Switch off the heating as soon as the rear window is clear. It will go off automatically after about 10 minutes.

If the battery voltage is lower than 12 V the heating will be switched off earlier so that the battery can get the benefit of the alternator charge.

Avoid placing sharp objects on the rear parcel shelf; the heater elements may suffer damage if such objects touch the rear window. Do not switch the heating on until you have started the engine.

Recommended settings in severe cold

On starting with a cold engine, set the fan switch to position 2 and select defrost to heat the cabin and defrost the windshield as quickly as possible.

When the engine is warm enough for the reading of the temperature gauge to start rising, fan setting 3 may be chosen. Once the windshield is clear, the air-distribution control should be shifted two steps to the left.

The warm-up time of the engine depends on the kind of driving. Town driving in high gear with a low RPM gives a longer warm-up time than highway driving with a higher RPM.

Do not use position 4 on the fan switch, as this is mainly intended to provide rapid cooling in hot weather.

Automatic climate control (ACC)

The air is drawn in through an intake at the bottom edge of the windshield. It passes through an efficient filter before being routed through the climate-control system and into the cabin. The cabin discharge vent is located on the right behind the rear bumper. The air discharge vents should be kept free of snow and ice in the winter.

ACC (Automatic Climate Control) automatically maintains the desired cabin temperature, regardless of the weather outside.

The system will achieve the desired temperature in the quickest possible way.

Note that heating or cooling is not speeded up by setting the temperature higher or lower than you really want.

For the ACC system to be most effective, all windows, and the sunroof if there is one, must be closed, and the panel vents must be open.

The incoming air is treated in three stages: first it passes through a filter; it is then dehumidified and cooled and, finally, if required, heated.

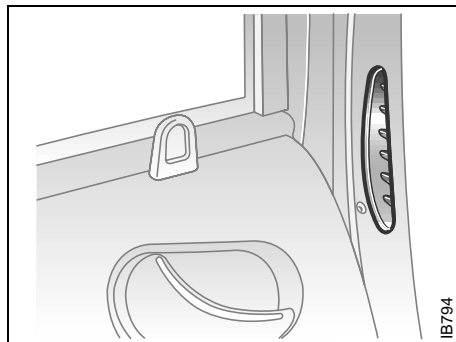

Air vent at rear side window

The temperature interval within which you can make adjustments is 58-82°F (15-27°C). Outside it, there is the HI position (max. heat and high fan speed) and the LO position (max. cooling and max. fan speed).

The displayed temperature is not the actual temperature but corresponds to the comfort level normally experienced at that temperature after allowance has been made for the air flow, relative humidity, solar radiation, etc., currently prevailing inside the car.

- The most usual temperature setting is 66-74°F (19-23°C), depending on personal preference and what clothing is worn.

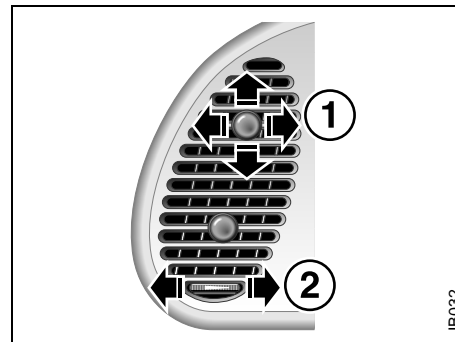

Dash vent

- 1 Adjusting the direction of the air flow.
- 2 Adjusting the air flow

- It is recommended that changes in the temperature setting be made in steps of 2°F (1°C).
- Conversion between °C and °F is done in the SID unit; see "Units and language versions", page 69.
- During the cooling phase in warm weather the panel vents must be open.
- Do not manually select recirculation in cold/wintery weather. The reduced air flow can cause misting and ice on the inside of the windows.

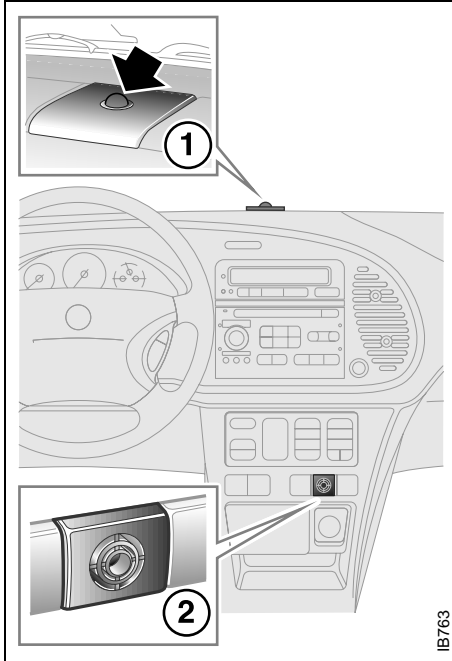

- 1 Sun sensor
2 Interior-temperature sensor

The system uses five sensors:

- Outside-air temperature.
- Cabin-air temperature.
- Sun sensor.
- Blended-air temperature (located in the heater unit).
- Coolant temperature.

The sun sensor is centrally located on the dashboard panel between the defroster nozzles. Note that if anything is placed over the sun sensor the ACC system will not function properly.

Condensation water



When the A/C compressor is on, the incoming air is dehumidified. The resulting condensation water is drained away through an outlet under the car.

It is therefore perfectly normal for water to be seen dripping from this outlet when the car is parked. The warmer the ambient air and the higher the humidity, the more condensation will form.









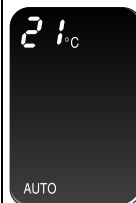

Functions



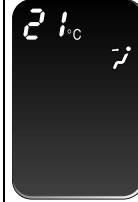

The function you have manually selected will be locked in, while other functions remain automatic. Temperature maintenance, except in positions HI and LO, is, therefore always automatic. The active function is shown in the display. A manual selection is cancelled by pressing AUTO or by repeated pressing of the button used to make the manual choice. For further functions, see "Programming II", page 87.

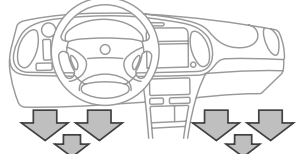

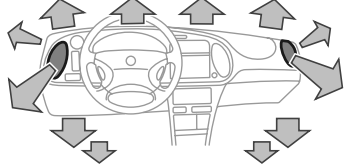

Button	Display	
		<p>Setting the cabin temperature</p> <ol style="list-style-type: none"> 1 Switch on the ignition. 2 Set the desired cabin temperature using the two buttons. 3 The temperature you have now chosen will be stored, remaining in the memory even when the ignition is switched off, unless ACC has been programmed with a different "ON" setting. See programming, page 86.

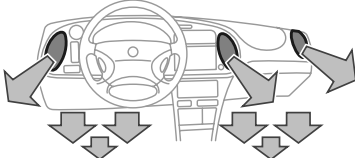
Button	Display	
		<p>When the system is set to AUTO, the temperature, air distribution, fan speed and recirculation will be controlled automatically. The air conditioning is activated automatically if the outside temperature is above 32°F (0°C). When AUTO is depressed again, all automatically selected settings are shown on the display.</p>

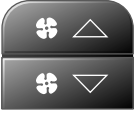
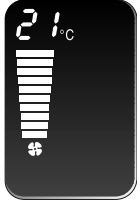
Button	Display	
		<p>One touch: When Defroster is manually selected you will get demisting of all windows (the air flow to the rear side windows will be shut off) by high fan speed. Air will be routed to the defroster nozzles. Normal temperature control, recirculation and ECON will be switched off but the electric heating of the rear window and outside mirrors will be switched on. Current settings will be shown on the display and AUTO will go out.</p> <p>The demister function remains operative until another selection is made, but the heating of the rear window and the outside mirrors will be switched off after a certain time, depending on the outside temperature.</p> <p>Two touches: Two touches on the defroster button routes the air to the windshield without any increase in fan speed and without switching on the rear-window heating.</p> <p>To revert to the previous setting, press the AUTO button.</p>

Button	Display	
		 <p>Panel (and center rear vent)</p>
		 <p>Floor, front and rear (and rear side windows)</p>
<p>Press simultaneously</p> 		 <p>Defroster - floor (front and rear)</p>

Button	Display	
Press simultaneously 		 Panel - floor (front and rear) and center rear vent
		Electrically heated rear window/electrically heated door mirrors are controlled automatically, though they can also be programmed for manual control; see "Programming II", page 87. The temperature, air distribution and fan speed will still be controlled automatically.
		Press \triangle or ∇ to increase/decrease the fan speed (the fan setting is shown on the display). To revert to automatic fan control, press AUTO. Other manual selections will revert to automatic control at the same time.

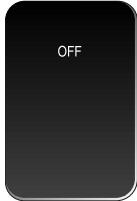
Button	Display	
		Recirculation is controlled automatically, but there is also manual ON/OFF control.
		When this function is activated the A/C compressor will be shut off. Reconnection can be made with one press on AUTO or pressing ECON. The function can be programmed for automatic A/C disconnection when the outside temperature falls below 57°F (+14°C), see "Programming II", page 87. The temperature, air distribution and fan speed will still be controlled automatically.
		After you have depressed OFF there will be no control. You can re-activate by pressing AUTO or by again pressing OFF, which gives the latest setting.

Starting in cold weather: The automatic climate control system selects the defroster position, max. heating and low fan speed to begin with.

As the engine temperature rises, the fan speed is increased and air is routed towards the floor.

As the temperature inside the car nears the selected value, both the fan speed and the heat will be decreased to a level determined by the system.



Starting in hot weather: The automatic climate control system selects air to the panel vents and high fan speed. Recirculation is switched on about 30 seconds after starting if the selected cabin temperature is markedly lower than the actual temperature.

Unless the ECON button has been depressed, the A/C compressor is always switched on at outside temperatures above 32°F (0°C) in order to cool and dehumidify the incoming air, unless the ECON button has been depressed.

As the temperature inside the car nears the selected value, the fan speed will be decreased to a value determined by the system.

Action to be taken in special types of weather

Normally, misting and icing problems on the windows do not occur other than in extreme situations, e.g. when you are driving in heavy rain or severe cold in combination with high air humidity or when those traveling in the car are sweaty and wet. If you have trouble with misting or icing in such cases we suggest the following countermeasures:

- 1 Select  and temperature 70°F (21°C).
- 2 Select . If this is not enough ...
- 3 Increase the fan speed. If this is not enough ...
- 4 Select a higher temperature.

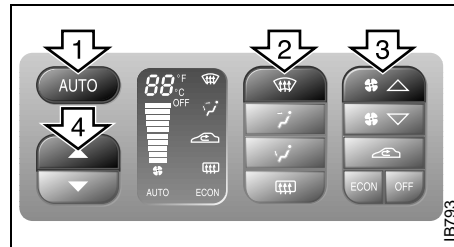

Air to the rear side windows is supplied by the floor ducts. To demist these windows you should therefore select a defroster/floor combination by pressing both buttons at the same time.



Calibration

If the battery has been disconnected or has run flat, the system will recalibrate automatically.

Manual calibration:

- 1 Start the engine.
- 2 Press  +  at the same time. The ACC display flashes once to indicate that calibration and self-testing have started.

During calibration the display indicates the figure 0 or the fault codes (01-23) that have been found.

Calibration and self-testing takes about 30 seconds.

Programming I



The manual selections you have made can be saved so that the ACC system always starts up on these selections every time the ignition is switched on. But notice that the ignition must have been off for at least 10 minutes before you try out the saved setting.

- 1 Select the desired settings.
- 2 Press  +  at the same time.



(The ACC background lighting flashes to confirm that the information has been stored.)

Example:

If you want the ACC system to distribute the air to the dash vents from the start, proceed as follows:

- 1 Start the engine.
- 2 Press the button .
- 3 Press  and  at the same time.
- 4 Shut off the key.
- 5 The system will memorize this new program 10 minutes after the key is shut off.



Cancelling program I

A saved setting is deleted only by pressing  +  at the same time.

(The ACC display flashes to confirm that deletion has been effected.)



Programming II

It is also possible to customize the ACC system to adapt to driving and weather conditions.

Function	Operation in AUTO mode after Programming II	Standard operation in AUTO mode
	The A/C compressor is not switched on until the outside temperature goes above +55°F (+13°C). – This function can be used to save fuel, since the A/C compressor will not be in action for so long a time. In wet weather, however, the A/C compressor should be on at below 57°F (14°C) as well, since this reduces the risk of misting on the windows.	A/C compressor cuts in when outside temperature is above 32°F (0°C).
	Rear-window heating can only be switched on manually.	The heating will come on about five seconds after the engine has started if the outside temperature is below +41°F (+5°C). –The activation time depends on the outside temperature.

Programming and cancellation of programming is carried out by holding the appropriate button down until the corresponding symbol has flashed 4 times, an audible signal has sounded and the following text for the desired function has appeared in the SID.

Make sure the ignition is ON.

Function	Text displayed on SID during programming	Text displayed on SID when cancelling program
	ACC: LO TEMP A/C CTRL	ACC: NORMAL A/C CTRL
	ACC: MANUAL RDEFR CTRL	ACC: AUTO RDEFR CTRL

Example:

If you want to control the switching on and off of the heating for the rear window and the door mirrors manually, hold the  button depressed until the symbol has flashed 4 times, an audible signal has sounded and the following text has appeared in the SID.

SID shows:
ACC: MANUAL
RDEFR CTRL

Once a function has been recorded under "Programming II", it will remain in the system until you cancel the program. AUTO will still show on the display after a function has been saved in "Programming II".

Additional programming features, see page 231.

Useful tips:

If the ACC system is not functioning satisfactorily the following should be tried before you take the car to an authorized Saab dealer.

- If the indication AUTO does not light up after starting (the ignition must have been switched off for at least 10 minutes): See Cancelling programming of ACC.
- If you think that the ACC system is not functioning satisfactorily you should:
 1. Check that the cigarette lighter plug is in its socket (since if the socket is empty heated air can flow out and affect the cabin sensor).
 2. Recalibrate: See the section headed Calibration.
- If the battery has been disconnected or has died, the ACC system should be recalibrated: See Calibration.

Programmed settings are not deleted if the battery has been disconnected.

Extinguishing the lighting in ACC

See section Night Panel, page 63.

ACC - 9-3 Convertible

When the soft top is folded down the ACC system goes over to manual temperature setting.

Between HI and LO there are eleven (0-10) fixed temperature steps.

The system adjusts itself as follows

- AUTO is turned off.
- Heating, air distribution and fan speed are not affected.
- Recirculation and electric rear window are turned off.
- A/C assumes the same setting (ON/OFF) as it had when the soft top was last folded down.

All manual selections are possible with the exception of electric rear window.

Saab recommends leaving the ACC setting on ECON when the soft top is folded down to improve fuel economy and unnecessary running of the A/C compressor.

When the soft top is raised the system reverts to the AUTO mode and the previous set temperature.



ACC display with soft top folded down

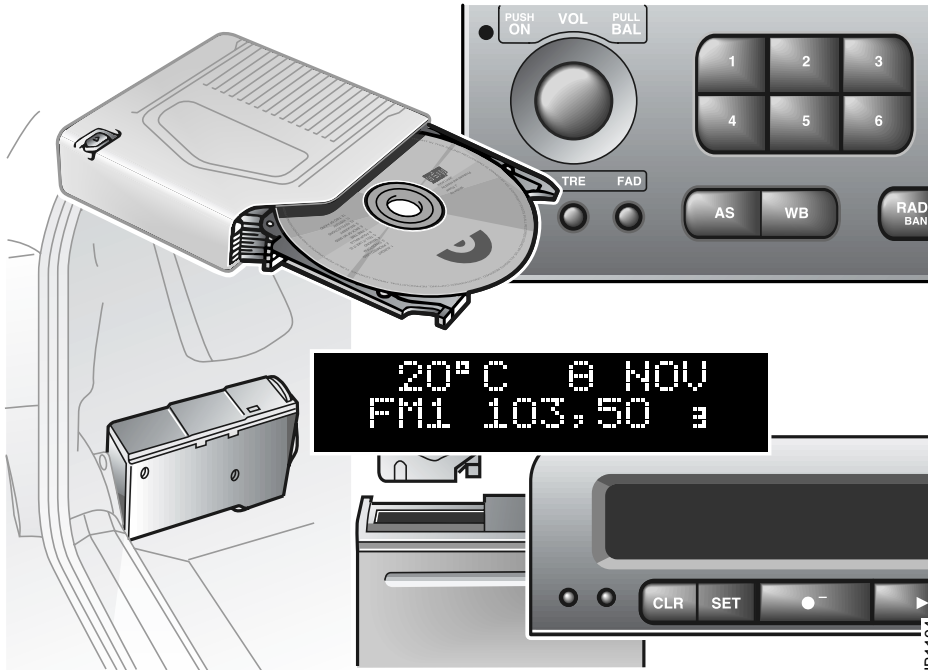

Saab 9-3 Audio System

Quick guide to the Saab 9-3 Audio System	91
Sound controls.....	93
Radio	94
Cassette player	96
CD player	99
CD changer.....	101
General functions	104
Steering-wheel controls ..	105
Security lock.....	105
Technical data	106
Installation of car phone (option).....	109
Fault codes	110

Saab 9-3 Audio System

The Saab 9-3 Audio System comes in two levels, Premium and Prestige. They are specially adapted to the cabin space in the Saab 9-3.

The Saab 9-3 Audio System consists of a main unit with a radio and a cassette player. There is also a CD player and a CD changer for 6 CD discs available as an accessory.

The Premium Audio System has two loudspeakers at the front and two at the rear. Output is 4x20 watts.

The Prestige Audio System 3 has two additional loudspeakers. They are mounted in the front doors and reproduce bass tones below 200 Hz. These subwoofers have their own amplifier of 2x40 watts.

The Audio Systems are interconnected with SID (Saab Information Display) which is located above the radio in the instrument panel. The Audio Systems uses the display of the SID instrument to show text/characters and indications.

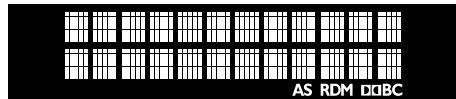

Indicator	
AS	Radio is in Autostore mode
RDM	Random playback of CD tracks when CD player selected
 (DOLBY B/C)	DOLBY B/C noise reduction on for cassette player

Quick guide to the Saab 9-3 Audio System

Radio, see page 94



On

To switch the system ON, press the volume button. The last settings used will be activated. If the Audio System is switched on when the ignition key is not in the switch, the system will automatically be switched off after one hour has elapsed since a control button on the radio was last pressed.

Off

To switch the system OFF, press the volume button or remove the ignition key.

VOL

To adjust the volume, rotate the VOL control.

BAL

To adjust the balance between the left and right channels, pull out and turn the VOL control.



BAS

Press to release the button, and adjust the bass level. Lock the setting by pushing the button in.

TRE

Press to release the button, and adjust the treble. Lock the setting by pushing the button in.

FAD

Press to release the button, and adjust the balance between the front and rear sets of speakers. Lock the setting by pushing the button in.



Preset station buttons

Press once: play the preset station.

Press and hold briefly: store a new station.



Auto tuning

Touch: SEEK.

Press and hold briefly: manual tuning.

Press SEEK once: frequency display



Touch: AS (AutoStore) ON/OFF.

Press and hold briefly: automatic tuning and storing of the 6 strongest stations in the area in which you are currently driving.



Touch: change frequency band.



Press once: Mute ON/OFF (on CD tuner only).



Press once: activate Weather Band

Cassette player. See page 96



Touch: choice of play when another sound source is active.



Changing cassette side.



Take out the cassette.



Touch: music search.
Touch and hold: fast wind.
Touch centrally on SEEK: Blank-skip off/on, see page 97.

CD player. See page 99

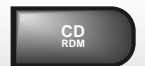

Touch: change to CD playback when other sound source is active.
Press and hold briefly: random playback.



Touch: SEEK at either end to change track.
Press and hold briefly: fast playback or fast track changes.
Touch center on SEEK: change between functions fast playback (PLAY) and fast track changes (TRACK).



Remove CD.

CD changer (option). See page 101



Touch: change to CD changer when CD player is active.
Two touches: change to CD changer when radio or cassette player is active.
Press and hold briefly: random playback of entire magazine.



Touch: SEEK at either end to change track.
Touch and hold briefly: fast playback.
Press SEEK (center) once: Switch between Rapid play (PLAY) and Fast track search (TRACK).



Selects disc in magazine.

Sound controls

ON/OFF

The Audio System will come on:

- When the volume control is pressed.
- When the ignition is switched ON, if the Audio System was on when the ignition key was last removed.

The Audio System will be switched off:

- When the volume control is pressed.
- When the ignition key is removed.
- One hour after the ignition was switched OFF, if the ignition key has not been removed.
- When one hour has elapsed since a control button was pressed if the Audio system was switched on when the ignition key was not in the switch.

VOL - Volume

BAL - Balance

Pull out and rotate the VOL control to adjust the balance between the left and right speakers. When the control is released, it reverts to the volume function.

BAS/TRE/FAD controls:

Rotate clockwise to increase the level and counter-clockwise to reduce it.



BAS - Bass

TRE - Treble

FAD - Fader

The fader control adjusts the balance between the front and rear sets of speakers.

The Bass, Treble and Fader controls must be pressed first to release them.

Radio

Press the RADIO/BAND button (3) to switch to the radio when another source is active.

Preset station buttons (1)

Press once (release within a second) to select a preset station, e.g.



The small figure on the far right of the display is the number of the preset button selected.

Presetting a station

Press the desired button and hold it down for more than a second to store the currently tuned station. During this time, the radio will be mute. The sound will return as soon as the station has been stored.



Seeking (2)

Automatic seek tuning:

Press SEEK >> briefly to search for higher frequencies or << SEEK for lower frequencies.

Manual tuning:

To switch to the manual-tuning function, press SEEK >> or << SEEK and hold until a chime sounds and the M indicator appears on the display.

The function will revert to automatic seek tuning two seconds after the last manual frequency change has been made.

Band selector (3)

Touch the RADIO/BAND button repeatedly to move through the waveband selections: FM1, FM2 and AM.

AS, Autostore (4)

The autostore mode provides an additional preset function that can be used to search for and to store stations when you are in an area where you are unfamiliar with the stations and their frequencies. This can be done without changing your normal presets. Touch the AS button to switch the Autostore mode ON/OFF. When the Autostore mode is ON, the AS indicator will show at the bottom of the display.

Press and hold the AS button for more than a second to initiate an automatic search for the six strongest stations.

Each time the system finds and stores a station, the number on the far right of the SID display will change. If the system cannot find six stations with good reception, the remaining preset buttons will be empty. If one of these empty buttons is pressed, FM or AM**** will appear on the display.

When the system leaves the AS mode, it returns to the station that was selected before the AS mode was activated.

The AS mode can also be used in the AM band.



WB (Weather Band) (5)

Press the WB button to select the Weather Band mode. The radio will automatically search for the strongest national weather service station in the area. When a weather band station is received, the display indicates "WB". The strongest station generally provides the most accurate information for the area in which you are travelling.

To exit the Weather Band mode, depress the WB button again. Weather Band reception is available in CD and RADIO mode. If the radio is unable to find a sufficiently strong station to lock onto, the unit will continue to search and the display will indicate "NO WB".

Cassette player

Before playing a tape, make sure that the label is secure and that the cassette is not warped, otherwise the cassette can become jammed in the deck. The cassette player senses automatically whether the tape is normal or metal (Type I or Type II).

TAPE (1)

Turn on the cassette player by pressing

 or by inserting a cassette in the deck, with the exposed tape to the right. Playback will start with the side that is facing up (indicated by A on the display). The display will now be as follows:



Playback direction (2)

To play the other side of the tape,

press .

The deck will automatically change the playback direction when the end of the tape is reached, be it during playback, fast forward/rewind or music search.



Dolby® noise reduction (3)

Press TAPE/DOLBY to switch Dolby B/C on/off.

Dolby should be on for playback of tapes recorded with Dolby, and off for those recorded without Dolby.

Eject button (4)

To stop playback of a tape, press the eject button  or select another source.

If you select another source without pressing the eject button, the tape will remain in the deck but the head and pinch rollers will release from the tape. The same applies if the Audio System is switched off while a tape is being played. Tapes can still be ejected when the system is turned off.

Music search forward/reverse (5)

To search forward for a track, press SEEK >> and release quickly (within half a second). The following will now appear on the display:



To perform a backward search, press << SEEK instead.

A forward search will continue until a gap of at least 4 seconds is found, or until you press SEEK >> or SEEK (mid-segment).

Pressing and holding the button during a search will initiate the fast-forward function.

Fast forward/rewind

Press and hold SEEK >> to start fast-forward to the end of the tape. The following will now appear on the display:



Press SEEK >> once to cancel fast-forward.

Press and hold SEEK briefly to switch to music search.

Fast rewind (<< WIND) is performed in the same way as fast forward.

Auto music search (Blank skip)

To switch the Blank-skip function ON/OFF, press and hold SEEK (mid-segment).

When the Blank-skip function is active (display: BL SKIP ON), unrecorded gaps that are longer than 15 seconds will automatically be skipped.

When auto music search is in progress, the following will show on the display:



If a track has been recorded at an unusually low level and is therefore identified incorrectly as a gap between tracks, it could initiate a spurious "auto music search".

To cancel such a search, press and hold SEEK (mid-segment) during playback. The following will now appear on the display:



Type II (metal) tapes

The cassette has an automatic tape-type selector.

Cleaning-due indicator

After 30 hours' playing time, the following message will appear on the display:



The message will be displayed for ten seconds each time the cassette player is selected.

A cleaning tape should be used to clean the heads inside the cassette player to maintain good reproduction and to prevent unnecessary wear.

To reset the playing-time meter:

- 1 Remove the current tape.
- 2 Load the cleaning tape and play it for the required time.
- 3 Remove the cleaning tape and reload the other one.

Tape care

Do not expose cassette tapes to direct sunlight or to extremes of temperature as this can damage the cassette and the tape.

Always keep cassettes in their boxes when not in use.

If a cassette should become jammed in the deck, seek help from an authorized Saab dealer.

CD player (option)

To select the CD mode, load a CD into the deck or, if one is already loaded, press the CD/RDM button.

Insert the CD, label-side up, and allow the mechanism to load it automatically. Playback of the first track will start and the following message will appear on the display:



A tiny, amber-colored LED indicator to the left of the disc tray is illuminated when a disc is loaded.

When all the tracks have been played, the CD player will restart playback from track 1. To cancel playback, press the eject or RADIO button.



Track search (1)

Touch << SEEK or SEEK >> repeatedly to move to preceding or following tracks. Touching << SEEK once will restart playback from the beginning of the current track. To change to the preceding track, touch SEEK twice.

Rapid play (passage search)

When << SEEK or SEEK >> is pressed and held, rapid play will be initiated, with the time and track showing on the display, e.g.:



If the button is depressed for more than 5 seconds, the rapid play will be even faster. Rapid play stops when the button is released.

Fast track changes

Touch SEEK (mid-segment) to switch between the CD PLAY and CD TRACK modes.



The CD PLAY and CD TRACK modes change the function of << SEEK and SEEK >>. The selected mode will also be active the next time the system is switched on. Choose the mode that you find most convenient:

CD PLAY	Pressing and holding << SEEK or SEEK >> starts Rapid play.
CD TRACK	Pressing and holding << SEEK or SEEK >> activates track changes.



Random playback (RDM) (2)

Press and hold the CD/RDM button to select/deselect random playback of the current disc. When this function is selected, RDM will appear at the bottom of the display.

Touch SEEK >> to move from the current track to the next during random playback.

Touch << SEEK to repeat the current track during random playback.

Pressing and holding << SEEK or SEEK >> will start Rapid play.

Eject (3)

Touch  to remove the disc.

If you press the eject button to open the tray but fail to remove the disc, the CD player will automatically close the tray again after 10 seconds to protect the disc, without restarting playback.

CD changer (option/accessory)

Important! Always keep the sliding cover closed to keep dust out of the CD changer, so that it will continue to provide satisfactory service for a long time.

To load the CD changer, which is installed in the trunk and can accommodate six CDs, proceed as follows:

- 1 Slide the cover back.
- 2 The CD magazine will automatically eject after it has retrieved all discs.
- 3 Press the catch on the magazine to one side.
- 4 Withdraw one CD tray at a time and swap or load the CD (label side up). Slide the tray back into the magazine.

Note the position of the magazine for loading (see picture).

Insert the entire magazine carefully inside the CD changer and slide the cover closed again.

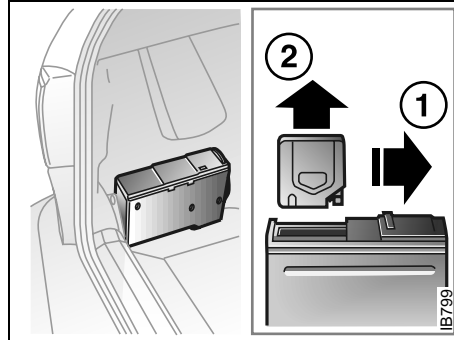

CD changer in trunk

To select the CD changer

- If the Audio System is in the RADIO mode, touch the CD/RDM button twice.
- If the CD player is active, touch the CD/RDM button once.

If the CDs in the magazine have not been changed, the system will restart playback from where it left off.

If there is no magazine in the CD changer, the following will appear on the display:

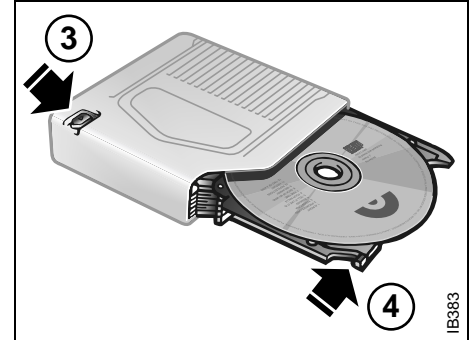

If the magazine in the CD changer is empty, the following will appear on the display:



If the CD changer is activated immediately after a magazine has been loaded, the following will appear on the display:



The CD number will change as each CD is played.

After a magazine has been loaded, playback will start with the first track on the first CD when the CD changer is selected, and the following will appear on the display:



Selecting CDs (1)

When the CD changer is operating, the radio preset buttons work for the six CDs in the magazine. Press the button for the corresponding CD.

If the selected CD is already being played, playback will restart from the first track.

If the selected CD-tray, e.g. 3, is empty, the following will appear on the display:



After two seconds, the status of the trays in the magazine (i.e. loaded or empty) will be shown on the display, e.g.:



If for some reason the CD selected by the preset button cannot be played, playback of the current CD will continue.

Track change (2)

Touch << SEEK or SEEK >> repeatedly to move to preceding or following tracks. Pressing << SEEK once will restart playback from the beginning of the current track. Thus, to play the preceding track, touch << SEEK twice.

Rapid play

When << SEEK or SEEK >> is pressed and held, rapid play will be initiated, with the time and track showing on the display, e.g.:



If the button is depressed for more than 5 seconds, the rapid play will be even faster. Rapid play stops when the button is released.

Fast track changes

Touch SEEK (mid-segment) to switch between the CD PLAY and CD TRACK modes.



The CD-PLAY and CD-TRACK modes change the function of << SEEK and SEEK >>. The selected mode will also be active the next time the system is switched on. Choose the mode that you find most convenient.

CD PLAY	Pressing and holding << SEEK or SEEK >> starts Rapid play.
---------	--

CD TRACK	Pressing and holding << SEEK or SEEK >> activates track changes.
----------	--

Random playback (RDM) (3)

Press and hold the CD/RDM button to select/deselect random playback of the CDs in the magazine. When this function is selected, RDM will appear at the bottom of the display.

Touch SEEK >> to move from the current track to the next during random playback.

Touch << SEEK to repeat the current track during random playback.

Pressing and holding << SEEK or SEEK >> will start Rapid play.

To stop playback from the CD changer, simply select another source (RADIO/CD). The CD changer will now enter stand-by mode.

General functions



WARNING

These functions should only be carried out when the car is stationary.

Volume-preset mode

To select the volume-preset mode, press and hold the WB button at the same time as you switch the Audio System on.

Use the << SEEK >> button to select the required function.

The following volume settings can be preselected:

- **START VOL** - **maximum** volume level when the Audio System is switched on.
- **TEL VOL** - preset volume level when an in-car phone is activated.
- **SP D VOL** - speed-dependent volume. The Audio System will automatically adjust the volume level to suit the background noise, such as road noise, occurring while the car is in motion.
- **LOUDNESS ON/OFF** - boosting of the highest and lowest frequency ranges to enhance the sound image when the volume is set to a low level.

Adjusting the volume

The default setting for START VOL is volume setting 9, and that for TEL VOL is volume setting 14 (the highest volume setting is 30).

- Maximum START VOL

- TEL VOL

To change the volume setting:

- Press and hold the WB button at the same time as you switch on the Audio System.
- Adjust the volume.
- Wait 10 seconds or touch one of the buttons on the bottom row of the Audio System, e.g. RADIO/BAND, to save the new volume setting.

Speed-dependent volume (SP D VOL) ON/OFF

To change the volume setting:

- The default setting for this function is ON.
- Press and hold the WB button at the

same time as you switch on the Audio System.

- Select SP D VOL using << SEEK >>.
- Select ON/OFF by turning the VOL control.
- Wait 10 seconds or touch one of the buttons on the bottom row of the Audio System, e.g. RADIO/BAND, to save the new volume setting.

Loudness ON/OFF

To change the loudness setting:

The default setting for this function is ON.

- Press and hold the WB button at the same time as you switch on the Audio System.
- Select LOUDNESS using << SEEK >>
- Select ON/OFF by turning the VOL control.
- Wait 10 seconds or touch one of the buttons on the bottom row of the Audio System, e.g. RADIO/BAND, to save the new volume setting.

Steering-wheel controls

To facilitate use of the Audio System and to promote safer driving, most of the functions can be operated using the integral remote controls on the steering wheel.

Control functions:

NXT (NEXT):

RADIO mode: preselect buttons

1⇒2⇒ ... ⇒6⇒1⇒ ...

TAPE mode: Play other side of tape.

CD mode: Inoperative.

CD-changer mode: Change CD in the magazine 1⇒2⇒ ... ⇒6⇒1⇒ ...

<< SEEK >>:

RADIO mode: Auto/manual seeking.

TAPE mode: Music search/Fast forward or rewind.

CD/CD-changer mode: Track change/Rapid play.

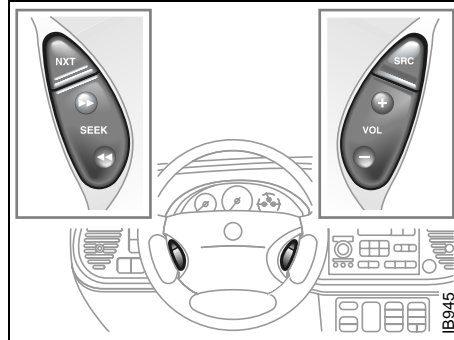

Audio System controls on steering wheel

SRC (SOURCE)

Press repeatedly to switch between RADIO ⇒TAPE or CD ⇒(CD changer) ⇒RADIO ⇒ ...

VOL +/-:

Volume adjust.

Security lock

The Audio System is equipped with an electronic security lock. The special code is unique to the car in which the Audio System is fitted.

Each time the Audio System is switched on, a check is made to ensure that the codes match.

If not, the following will appear on the display:

20°C 8 NOV
RADIO LOCKED

If a CD changer has been installed, it will also have been security coded.

If the security code for the CD changer does not match when the changer is selected, the following will appear on the display:

20°C 8 NOV
CDC LOCKED

If a CD changer is to be installed or if you wish to move the main audio-system module and/or CD changer to another car (Saab 9-3), you *must* consult an authorized Saab dealer so that the modules can be given the correct security codes.

Technical data

Tone controls

Bass _____ ± 12 dB at 40 Hz
 Treble _____ ± 10 dB at 15,000 Hz

Power output _____ 4 x 20 W (4 x 12 W at 1% THD (total harmonic distortion) and 13.5 V)

Radio module

Radio system _____ PLL dual-synthesizer tuner

Number of presets

FM _____ 3 x 6
 AM _____ 2 x 6

Frequency range

FM _____ 87.9 MHz – 107.9 MHz
 AM _____ 530 kHz – 1710 kHz
 WB _____ 162.40 – 162.55 MHz

Scanning steps

Automatic seek tuning: _____ VHF (FM) 200 kHz
 AM 10 kHz
 WB 50 kHz

Manual seek tuning: _____ VHF (FM) 200 kHz
 AM 10 kHz

Cassette player

Fast forward/rewind _____ < 110 s (C-60)
 Frequency range _____ 50 Hz - 12500 Hz ± 3 dB
 WOW _____ 0.1% WRMS
 Signal-to-noise ratio _____ 45 dB
 Dolby NR effect _____ 10 dB

CD player and CD changer

1-bit system and 8 x oversampling
 Frequency range _____ 5-20000 Hz
 _____ ± 0.5 dB
 Stereo separation _____ 45 dB
 Distortion _____ < 0.008%
 Dynamics _____ > 95 dB (1 kHz)
 CD-changer capacity: 6 discs

Amplifier (cars with extra speakers in front doors)

Power output _____ 2 x 40 W (2 x 30 W at 1% THD 50 Hz)
 Crossover frequency _____ 110 Hz (-3 dB)

- These specifications comply with the new IHF Standard
- Since the policy at Saab is one of continual improvement, we retain the right to alter specifications and design without prior notice.
- Dolby noise reduction is produced under licence from Dolby Laboratories Licensing Corporation
- "Dolby" and the double-D symbol  are trademarks of Dolby Laboratories Licensing Corporation

Changes or modifications not expressly approved by the manufacturer for compliance could void the user's authority to operate the equipment.

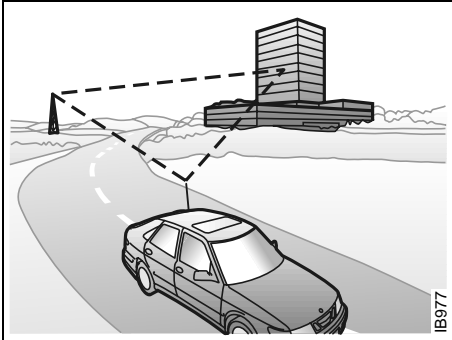

Multipath interference

When the radio waves from an FM transmitter collide with a large building, for example, they will be reflected so that they reach the car antenna slightly later than the direct waves. This is referred to as multipath distortion. The effect is liable to be blamed upon malfunctions in the radio.

Antenna

The antenna of the Audio System is motorized.

Saab 9-3 Viggen Coupé and 5-door: The antenna is located on the roof.

NOTE

Remove the antenna if you wash the car in a car wash, to avoid it being damaged.

For the cleaning of the motorized antenna, see the section headed "Washing", page 201.



Shadow effect

Because FM radio waves travel in straight lines from the transmitter, a shadow effect can occur when tall buildings or hills obstruct the interference path from the transmitter to the car.

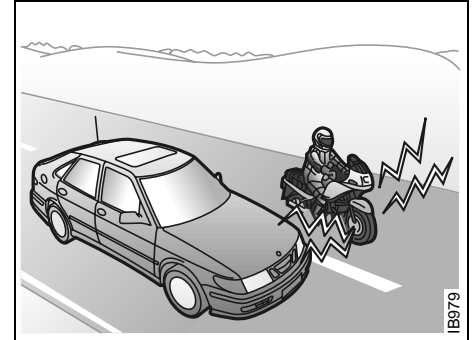

Sources of FM interference

Interference to FM reception can be caused by the electrical systems in other vehicles, particularly if the signal from the transmitter is weak.

To maintain good radio reception do not tint the rear windshield, particularly with film containing small metal flakes.

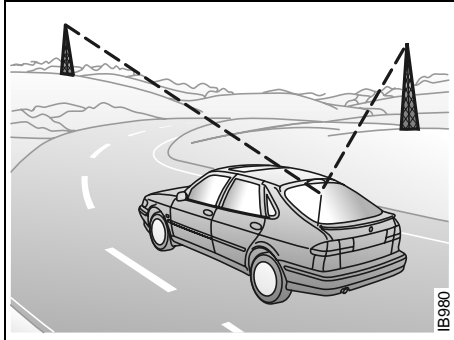

Cross-modulation

When the radio is tuned to a weak transmitter in the vicinity of a stronger one, the car's antennas will receive signals from both. Such interference is apparent when the unwanted broadcast can be heard faintly in the background.

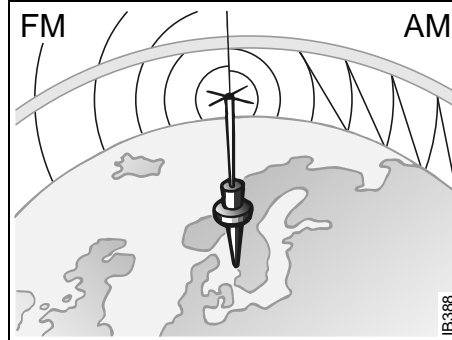

Radio waves, FM/AM

FM radio waves radiate in straight lines from the transmitter. Because such waves do not follow the curvature of the Earth, their strength becomes weaker the further they travel. That is why a large number of transmitters are needed to provide good reception.

AM waves, on the other hand, are reflected off the ionosphere, thus greatly extending their range.



Sources of AM interference

AM reception is prone to interference, e.g. from electrical systems on other vehicles, high-tension power lines and lightning.

Installation of car phone (option)

WARNING

To prevent crashes while using a cell phone:

- Do not use the cell phone in distracting traffic situations. Turn it off if traffic is heavy.
- Dial sensibly, at a stoplight or safely off the road.
- Consider installing hands-free or speaker phone.
- Avoid stressful and intense phone conversations.

NOTE

The A-pillar area (area beside the windshield) and the headlining of your Saab contain padding designed to reduce head injuries. No modifications to these areas should be made unless done by your authorized Saab dealer.

Provision has been made on certain variants of the Saab 9-3 for the installation of a hands-free car phone.

Installation must be done by an authorized Saab dealer.

A car-phone cradle is available as an accessory.

Your Saab dealer has details of which phones are suitable for the installation.

Provision for hands-free phone (Convertible, only if Saab 9-3 Audio System is fitted)

- Car phone connects to car's circuitry.
- Coaxial cable for external antenna is pre-run.
- Microphone for hands-free phone use incorporated in overhead panel at front (not Convertible).
- Audio System mute functions when phone activated.
- Phone conversation amplified through Audio System speakers.

- "TELEPHONE" appears on the SID when phone is in use.

TELEPHONE

- Volume level for ongoing conversation can be adjusted by volume controls on steering wheel or on audio-system module. See also "Volume-preset mode", page 104.
- If the sound is a bit fuzzy, adjust by means of the volume control on the *phone set*.
- Phone battery is charging when ignition is ON and phone in its cradle.

Please refer to the instructions supplied with the phone for details of how to make and receive calls.

OnStar System (US Only Option)

Your car may be equipped with OnStar, a vehicle telematics system for communication and navigation. Please consult the separate owner's manual for OnStar provided in your document organizer.

Mobile phones and communications radios

Mobile phones and communications radios that **do not have** a separate external antenna radiate an electromagnetic field inside the car.



The electromagnetic field inside the car can be detrimental to your health.

NOTE

The electromagnetic field can cause interference with other electrical systems in the car, such as the Audio System.

Saab therefore recommends that a car phone/radio transmitter should always be connected to an **external antenna**.

An external antenna also provides improved transmission/reception and a greater range.

Mobile phones and communications radios that are not supplied as standard equipment by Saab can interfere with the car's electrical system and cause misleading fault codes to be generated.



Always consult an authorized Saab dealer for installation guidance.
If you feel that any of the warnings or fault indications are unclear, have the equipment checked by an authorized Saab dealer.

Fault codes

NOTE

Great care should be exercised in trying to rectify a fault. If you are at all unsure, contact an authorized Saab dealer.

The Audio System has a built-in diagnostics function. If a fault is detected, a fault code is generated to help dealer technicians to diagnose the fault. Below is an example of a fault code that you might be able to rectify yourself.

Fault code	Possible cause
CD/CDC ERROR 12/17/19	CD is dirty, loaded wrong side up or defective.
TAPE ERR 01	Tape broken or mechanical fault in deck.

TAPE ERR 02/03	Tape snarled up or mechanical fault in deck.
TAPE ERR 11	Cassette jammed: cannot be loaded/ejected.



The CD player/CD changer is classified as Class 1 laser equipment.

- Service and repair work must only be carried out by authorized technicians.
- If the casing is damaged, hazardous laser radiation can occur.

Adjusting the frequency steps North America/Europe

If the car is taken from Europe to North America, the radio's frequency steps will need to be adjusted.

- With the radio off, press and hold SEEK (mid-segment) and switch the radio on at the same time.
- The station presets will be cancelled and replaced by preset frequencies.

Interior equipment, trunk

Seats	112
Steering-wheel adjust- ment	118
Electrical windows.....	119
Sunroof (option).....	120
Interior lighting.....	121
Cup holder	122
Ashtrays (accessory).....	123
Glove compartment	123
Rear-view mirrors	124
Trunk, Coupé and 5-door	125
Tools and spare wheel	130
Manually opening the fuel filler door	131

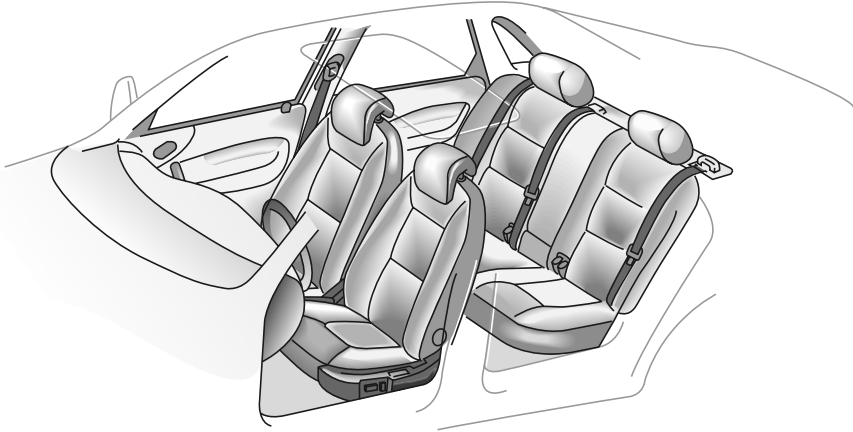

Seats

The following seat adjustments can be made to achieve a comfortable driving position:

- Height (driver's seat).
- Legroom.
- Backrest rake angle.
- Lumbar support.
- Head-restraint height.

We recommend that adjustments to the driver's seat be performed in the following order:

- 1 Height.
- 2 Legroom.
- 3 Backrest rake angle.

Lastly, adjust the steering wheel (see page 118).

WARNING

Never adjust the driver's seat except when the car is stationary.

Side airbags (SRS)

See page 27.

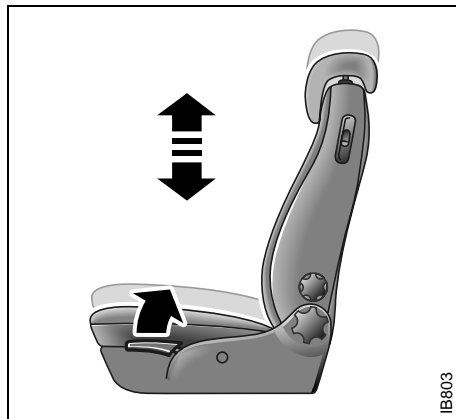

Height adjustment, driver's seat

Lift the lever to raise the seat. The lever is spring-loaded to return to its neutral position. Repeated lifting of the lever will increase the height in steps.

Press down the lever to lower the seat. Repeated downward presses of the lever will lower the seat in steps.

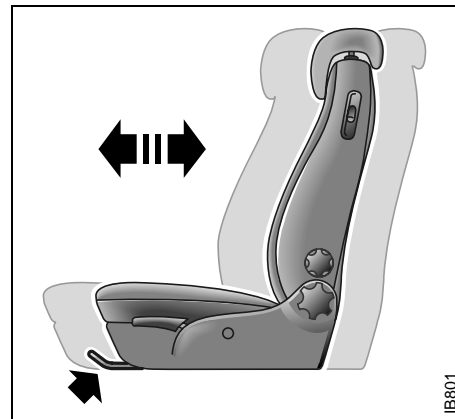

Legroom adjustment

Lift the lever under the front of the seat and slide the seat to the desired position.

WARNING

Check that the seat is locked in the new position - if not, it may move while the car is being driven. If the fore-and-aft setting of the seat has not been locked, it could result in injury to the occupant in the event of an accident.

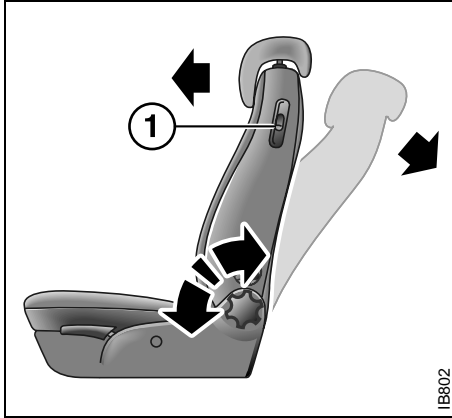

IB802

Adjusting the backrest

- 1 Catch, backrest (Coupé and Convertible versions)

WARNING

The backrest should be upright during driving, so that the safety belt, airbag and backrest can provide optimum protection in the event of emergency braking or a collision.

Center armrest

Certain models have a foldable center armrest that is attached to the driver's seat.

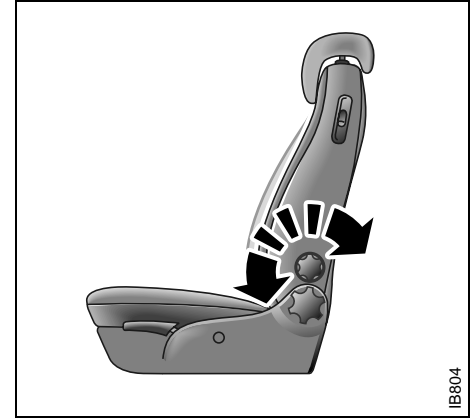

IB804

Lumbar support

Turn the smaller knob for stepless adjustment of the lumbar support.

Backrest rake angle

To find the most comfortable position, turn the knob to provide stepless adjustment of the backrest.

Head restraint

The front seats in the Saab 9-3 are equipped with Saab Active Head Restraints (SAHRs). These reduce the risk of whiplash injury if the car is hit from behind at low speeds.

In the event of a rear-end collision, the body is forced back against the backrest. This, in turn, causes the mechanism to press the head restraint forward and upward, thus limiting the backward movement of the head.

The SAHR is a mechanical system, actuated by body weight. The mechanism is built into the top of the backrest, where it is connected to the head restraint.

Because the SAHR is mechanically operated, it does not need to be replaced after a collision has occurred.

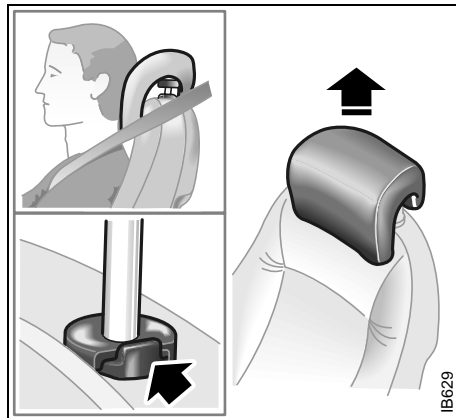

The head restraint can be raised or lowered and is adjustable in various positions.

- Raising: grasp the head restraint on both sides and pull it straight up.
- Lowering: depress the catch on the left-hand side of the attaching point and press the head restraint down.

WARNING

Adjust the head restraint so that the head is well supported and the center of the head restraint is at ear height, thus reducing the likelihood of neck injury in an accident.

Front seats, Coupé and Convertible versions

Both front seats have release levers on the outside of the backrest. The passenger seat also has a release on the inside of the backrest so that the driver can tilt the backrest for the convenience of rear-seat passengers.

Raise the release levers to tip the backrest forward.

Manually adjustable front seats with "Easy Entry" function, Coupé and Convertible versions

Manual seats have a feature called "Easy Entry", which facilitates movement to and from the rear seat.

Activate "Easy Entry" as follows:

- 1 Raise the release lever and hold it in its uppermost position until the backrest is tipped forward.
- 2 Slide the seat forward. The whole seat is now shifted to its forward position.

Resetting:

- 1 Slide the seat back to the desired position.
- 2 Fold the backrest to the upright position. Lock the front to rear seat adjustment.

After resetting you should ensure that the backrest and seat are properly secured.

WARNING

- Always check that the catch engages properly after the backrest is raised.
- Check also that the seat's lateral adjuster is properly secured by trying to shift the seat. Both the backrest and the whole seat must be locked in place; otherwise you are at risk of injury during braking or in a collision.

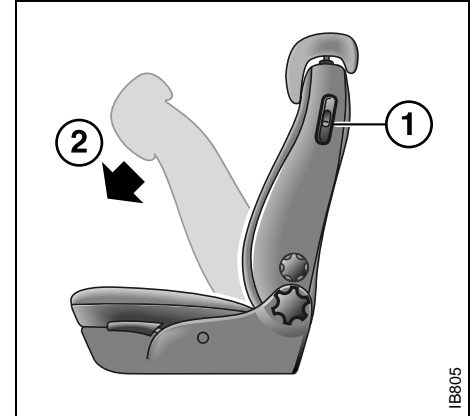

Manually adjusted front seat, Coupé and Convertible versions

- 1 Release lever, tipping backrest forward
- 2 Activation of the "Easy Entry" feature when the backrest is tipped forward

Electrically adjustable front seats (certain variants)

Both seats can be operated from outside when one of the front doors is opened, to improve access to the car.

For safety reasons, if the door is closed, the seat can only be adjusted when the ignition is ON.

Note, that both front seats can be adjusted up to 30 seconds after the door has been closed.



WARNING

The seats are actuated by powerful motors. Bear this in mind when adjusting the seat, and make sure that nothing gets caught and damaged.

Bear in mind that children can be injured if they play with the electrically-operated seats.



Height

Raise the seat by lifting the front switch bar straight up.

Lower the seat by pushing the front switch bar down.

The same switch bar can be used to adjust the height of the front and rear edges of the seat independently by moving half of the switch in the direction desired.

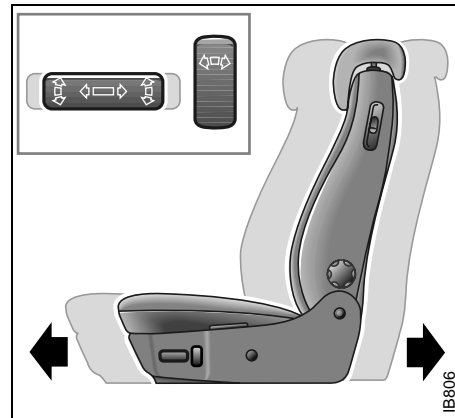

Legroom adjustment

For power seats, slide the switch bar forward or rearward to the desired position.



Backrest rake angle

Push the rear lever forward or rearward to adjust the rake angle of the backrest.

Memory function (certain variants)

In some variants the electrically adjustable driver's seat has a memory function. Three different settings can be programmed.

- 1 Make the desired adjustments to the seat setting.
- 2 Store the setting of the seat by keeping the "M" depressed and at the same time pressing one of the memory buttons, 1, 2 or 3. The SID will acknowledge storage with a chime.

When you next wish to activate the memory function, keep the desired memory button depressed while the seat adopts the programmed settings.

To change any of the three programmed settings, repeat stages 1 and 2.

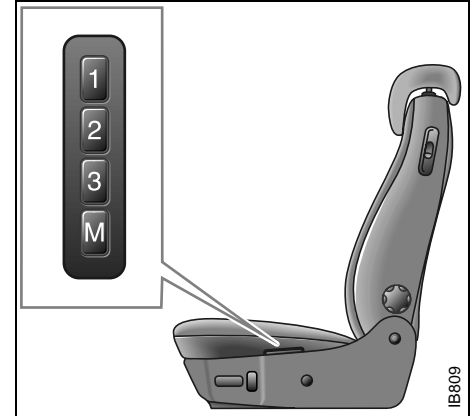

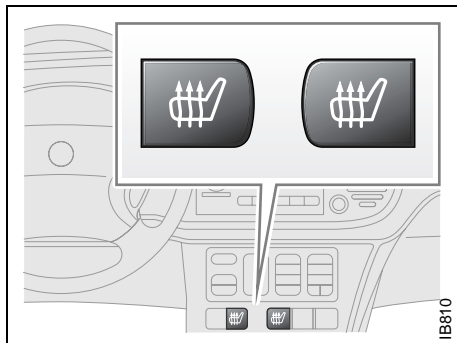

**Electrically heated front seats
(option on some model variants/markets)**

Both front seats incorporate heating for the seat cushion and backrest. It is switched on and off using the buttons on the instrument panel.

The heating is thermostatically controlled. It comes on when the temperature of the seat cushion goes below 79°F (26°C) and turns off when it reaches 97°F (36°C).

Shut off the heating once the seat is warm.

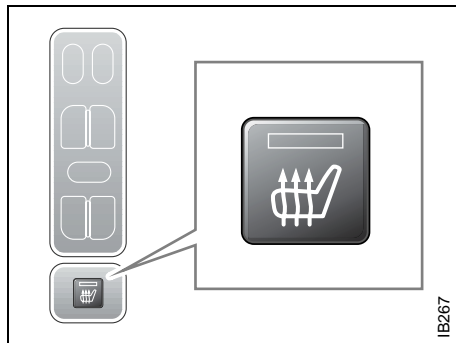

**Electrically heated seat cushions
in the rear seat
(option on some model variants /
markets)**

Electrically heated seat cushions for the two outer seats in the back are available as an option.

The ON/OFF control button for the cushion heating is located on the back of the center console.

The warming-up time varies with the temperature outside. You can also switch the heat off by means of the button.

The button has an integral indicator that is illuminated when the heating is on.

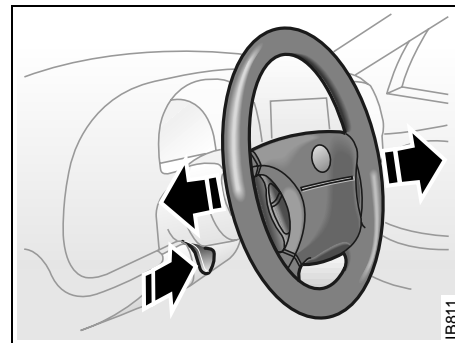

Lever for steering-wheel adjustment

**Steering-wheel
adjustment**

The steering wheel can be positioned fore-and-aft by pulling the lever to the left. Set the steering wheel to the desired position and return the lever to the locked status.

 WARNING
<p>For safety reasons, you should adjust the steering wheel only while the car is stationary.</p>

Horn signal

The horn is operated by pressing at the outer edges of the airbag module in the center of the steering wheel.

Electrical windows

WARNING

- Bear in mind the pinch hazard when the side windows are being raised. Make sure that all passengers keep their heads, hands and fingers clear of the window openings before you begin raising the windows.
- Always remove the ignition key when leaving the car to avoid the danger of injury arising from unattended children operating the windows.

The electric window motors are equipped with overload protection. If this protection should trip, wait several seconds before operating the electric windows again.

To open

Press the window symbol on the button.

The switches for the front windows have a third position for automatic opening of the window. Press the switch down all the way to lower the window completely.

To cancel automatic lowering of the window, lift the switch briefly.

To close

Lift the symbol side of the button.

The actuating motor will be switched off automatically when the window is fully closed or when the switch is released.

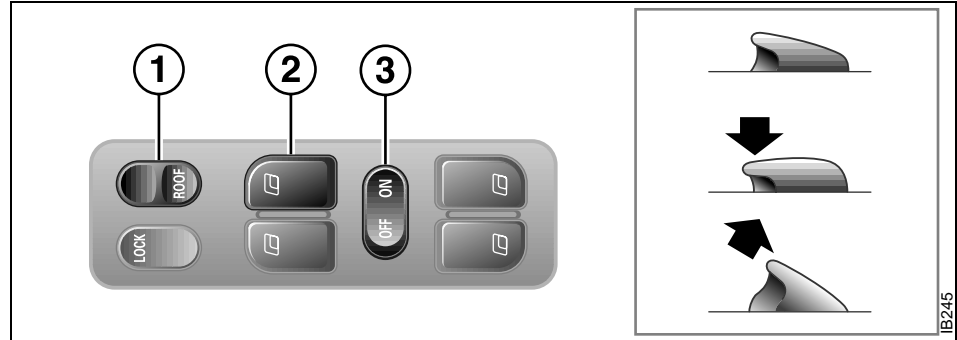

- 1 Control, sunroof (soft top operation, Convertible)
- 2 Window switches, front
- 3 Control for disengaging the window switches at the rear

Child safety: rear windows (ON/OFF)

The window switches on the rear doors can be rendered inoperative by the ON/OFF switch in the panel on the center console.

When the switch is ON, the rear side windows can be operated by the switch on each rear door.

When the switch is OFF, the rear side windows can only be operated from the panel on the center console.

Extra button for the rear window operator

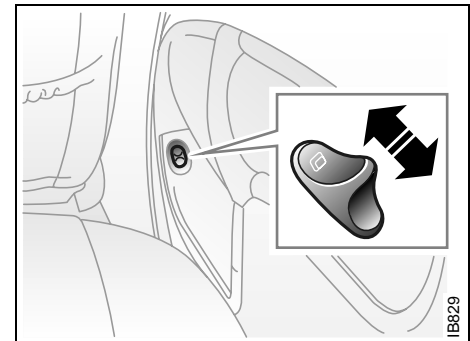

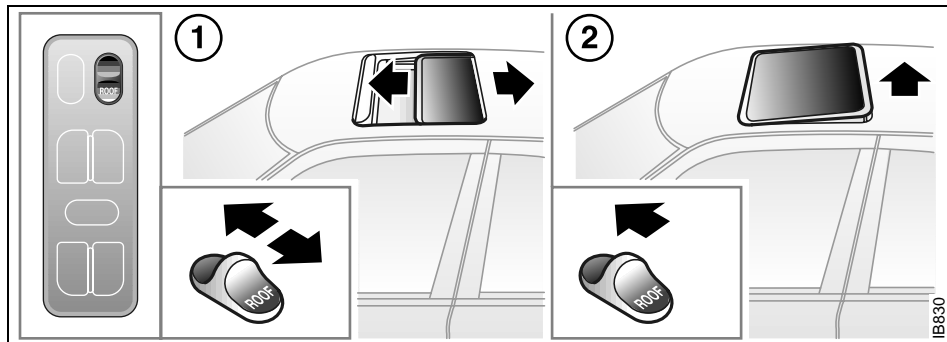

Sunroof (option)

The sunroof is operated electrically using the ROOF control on the center console. The sunroof can be opened completely or partially. As soon as you release the control the sunroof stops.

- 1 If you wish to open the sunroof all the way from the closed position, proceed as follows:
 - To open: slide the control rearwards.
 - To close: slide the control forwards.
- 2 You also have the option of opening the rear edge of the sunroof from the closed position for the purpose of ventilation.
 - To open: slide the control forwards.
 - To close: slide the control rearwards.

But you must release the control after each position so as to shift between the two functions.

The sunroof also has an inner sun blind that slides by hand.

WARNING

Be alert to danger of fingers being trapped when operating the sunroof.

Always remove the ignition key when leaving the car, to avoid the danger of injury arising from unattended children operating the sunroof.

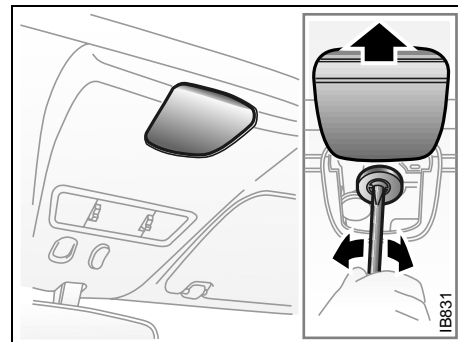

Emergency operation of the sunroof

The sunroof can be operated manually with a screwdriver, e.g. in the case of an electrical fault. Slide back the cover on the roof console. Insert a screwdriver into the slot in the center of the motor shaft and turn

Turn clockwise to open the sunroof.

Turn counterclockwise if the sunroof is open at the rear edge.

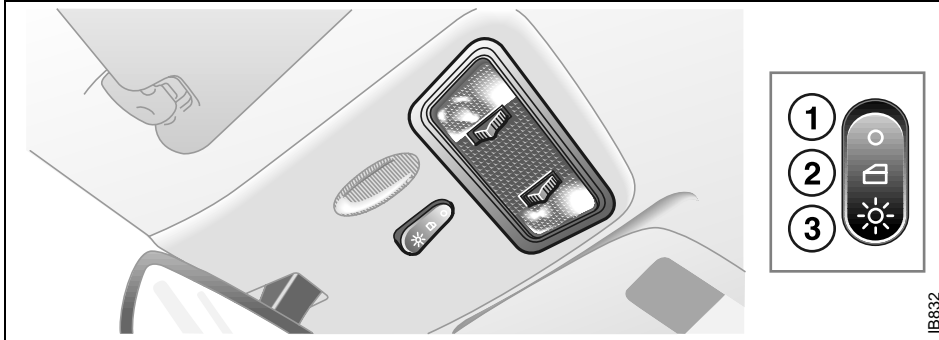

- 1 Interior lighting is off
- 2 Lighting comes on when a door is opened
- 3 Interior lighting on continuously

Interior lighting

The interior lighting consists of one dome light in the front and one in the back. The switch for the interior lighting is on the overhead panel next to the rearview mirror.

When the switch is in the mid-position (door-activated), the interior lighting will come on:

- When the car is unlocked from outside.
- When any door is opened with the ignition off.
- When the ignition key is withdrawn from the switch.

The lighting goes out about 12 seconds after the doors are closed or when the ignition is turned on, provided that the switch is in the mid-position.

If the doors are left open and the switch is in position 2 or 3 with the ignition off, the interior lighting is turned off automatically after 20 minutes to preserve battery life.

The sun visors are equipped with vanity mirrors. On certain model variants, the sun visors are fitted with vanity lighting, which turns on when the cover is lifted.

9-3 Convertible: see page 52.

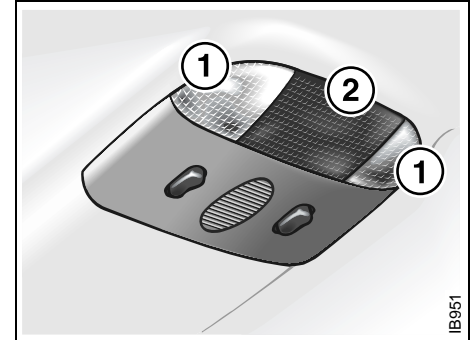

Rear-seat lighting

- 1 Reading lights
- 2 Dome light

Trunk lighting

The trunk lighting is switched on and off when you open and close the trunk, if the switching button is set to ON. The lighting can also be switched on and off using the button on the light.

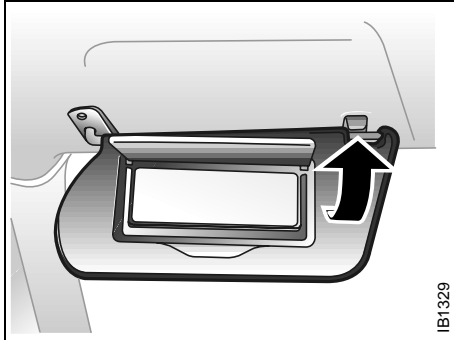

Sun visor with vanity mirror

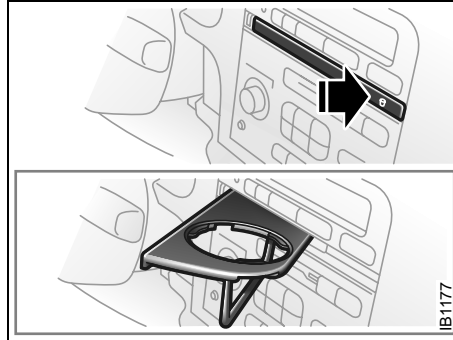

Cup holder

There are two cupholders, one in the fascia under the SID unit and one in the center-console compartment between the front seats on certain models.

Next to the cup holder between the front seats is a coin tray.

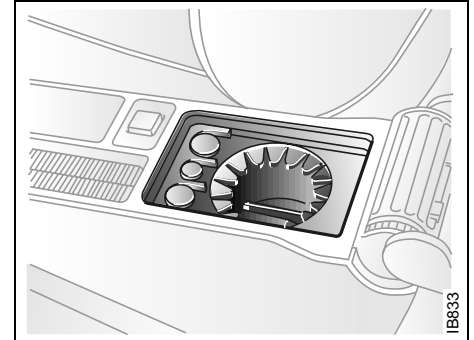

Cup holder in the center console

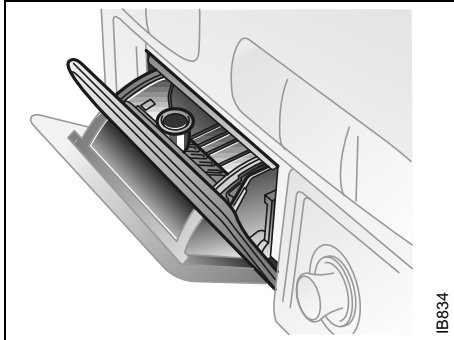

IB834

Front ashtray

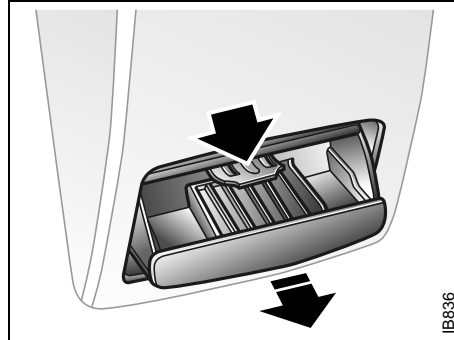

IB836

Rear ashtray

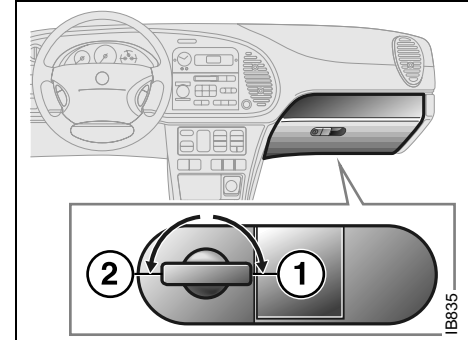

IB835

Glove compartment

- 1 To unlock
- 2 To lock

Ashtrays (accessory)

The car is equipped with two ashtrays. One is positioned low down on the dash and the other on the back of the center console. Open the front ashtray by lightly pressing on the front. Remove it by depressing the catch on the underside. You do not need to open it in order to take it out. To replace it, just push it straight in.

Open the rear ashtray by lightly pulling its upper edge rearward. Remove it by depressing the catch and opening it past the catch point.

To put it back, align it with the two locating pins on either side of the opening, then push it closed.

The cigarette lighter socket can also be used as a power supply for a mobile phone or other electrical accessory.

WARNING

The maximum output that can be taken from the cigarette lighter socket is 240 W (20 A).

Glove compartment

WARNING

The glove compartment must be closed while travelling. An open glove-compartment door could cause leg injuries in the event of a collision.

There are additional storage pockets on the front edges of the front seats and on the passenger side of the center console.

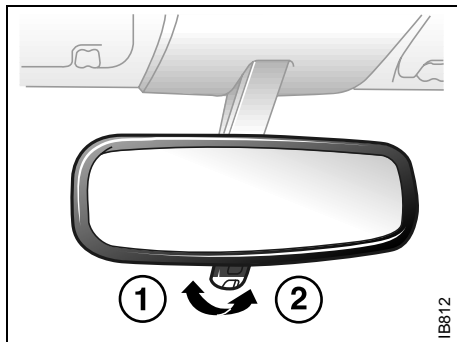

Rear-view mirror

- 1 Day position
- 2 Night position

Rear-view mirrors

The rear-view mirror has day/night positions that can be selected by means of a knob beneath the mirror. Adjust the mirror for best vision in the day position and pull the tab on the bottom of the mirror toward you for the night position.

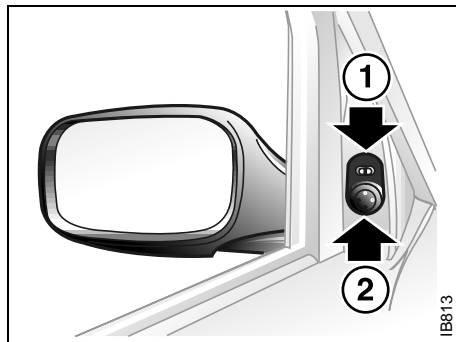

Adjusting the door mirrors

- 1 Select mirror
- 2 Use touch pad to adjust mirror

Door mirrors

The door mirrors are electrically adjustable. The controls are on the driver's door.

- 1 Use the upper button to select a door mirror.
- 2 Use the touch pad to set the mirror vertically and horizontally. There are raised points at the 12, 3, 6 and 9 o'clock positions to indicate adjustment points.

If subjected to a certain force, the whole mirror will fold back to prevent injury.

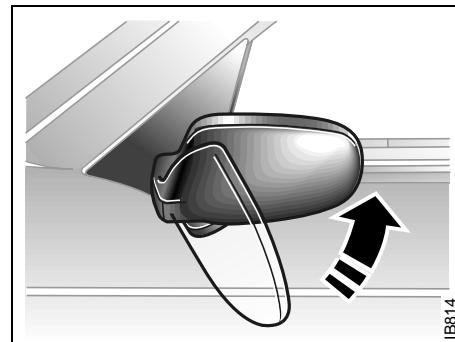

Retracting a mirror

The mirror can also be retracted by hand, which can be useful when parking in confined spaces, e.g. on car ferries. Don't forget to fold the mirrors out again before driving away.

The electric heating of the door mirrors is switched on and off with the same button as the heating of the rear window.

NOTE

The door mirrors should be retracted before the car is put through an automatic carwash.

Trunk, Coupé and 5-door

WARNING

When the back seat has been put back in place, make certain that the belt beam is locked firmly on both sides (the red warning tabs must go down). **This is vital since the upper anchorages for the safety belts are located in the belt beam.** The belts will not restrain a rear seat occupant if the belt beam is not properly latched.

When the entire rear seat has been lowered, you must remove the rear window shelf. Otherwise it could come loose and cause personal injury during a collision.

Trunk lid lock

Unlock the trunk lid by pressing the lower button on the remote transmitter, by pressing the remote release button on the driver's door or by using the key. The alarm horn sounds three times and the lights flash when the trunk is released with the remote control. Programming features, see page 231.

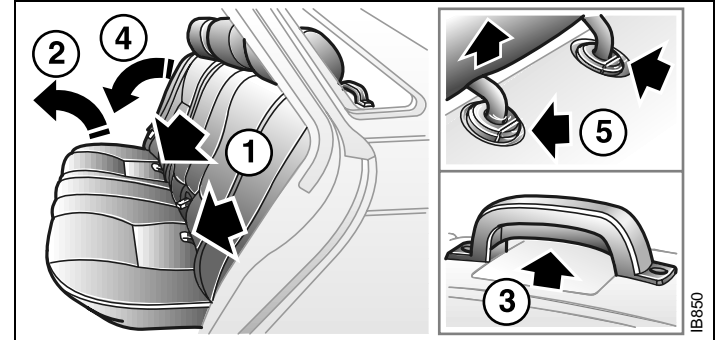

Lowering the entire rear seat

To lower the rear seat, the front seats must be moved forward if they are in the most rearward position. The seat back must be almost vertical.

- 1 Flip up the seat bottom by pulling the loops located between the backrest cushions and seat cushions.
- 2 Rest the seat cushions on edge just behind the front seats.
- 3 Release the entire backrest cushion, including the belt beam, by pressing in the latch in the handle on the left (driver's) side. After this has been done, the fact that the belt beam has been released is indicated by the red "warning tabs" popping up on the right and left sides of the beam. For increased load capacity with the backrest cushion down, remove the rear seat head restraints (5).

- 4 Lower the entire backrest cushion by pulling this same handle (item 3) forward. At the same time, pivot the beam backwards. **IMPORTANT:** When you replace the belt beam using the handle (item 3), you must verify that it is properly locked and that the two red "warning tabs" go down (thereby indicating that locking has taken place properly).
- 5 To increase the volume, the rear head restraints can be removed before the backrest cushion is lowered.

 **WARNING**

Never leave a child or animal unattended in the car. During sunny weather the temperature in the cabin/luggage compartment can climb to 160-180°F (70-80°C). Small children are very susceptible to heat stroke.

Lowering the right-hand part of the rear seat

 **WARNING**

- If the head restraints have been removed, they must be stored safely so that they cannot be thrown about and injure someone while braking or in a collision.
- Do not ride in the rear seat without having remounted the head restraints, and making sure they are properly locked in place.
- Whenever you handle any system containing moving parts, such as the belt beam, always be careful not to get pinched.
- Never keep objects on the rear window shelf since they can be thrown forward and cause personal injury during heavy braking or in the event of a collision.
- When the back seat has been put back in place, make certain that the belt beam is locked firmly on both sides (the red warning tabs must go down). **This is vital since the upper anchorages for the safety belts are located in the belt beam.** The belts will not restrain a rear seat occupant if the belt beam is not properly latched

To provide more flexibility, the rear seat is divided so that you can lower the narrower (right) part separately.

- 1 Tilt the seat cushion forward by pulling the loop located between the backrest and the seat cushion.
- 2 Stand the seat cushion on end behind the front seats.
- 3 Release the right backrest cushion by means of the latch on the belt beam's **right** side just behind the head restraint.
- 4 Lower the right backrest cushion.

IMPORTANT: When you replace the right backrest cushion, make certain that it is properly locked.

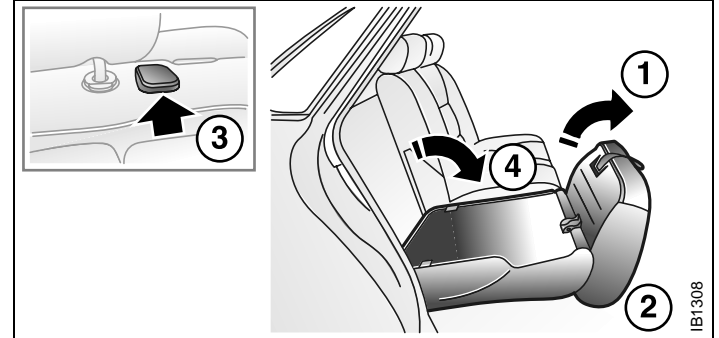

Warning tabs

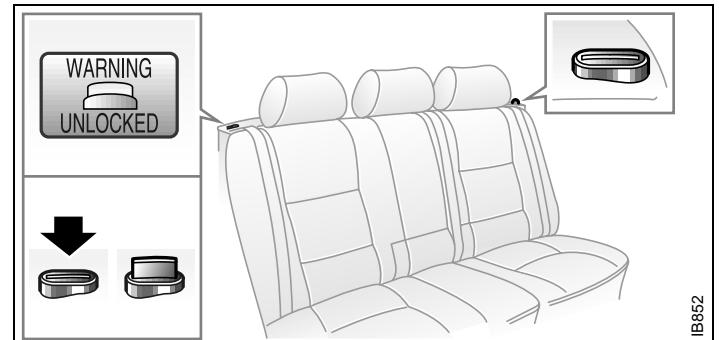

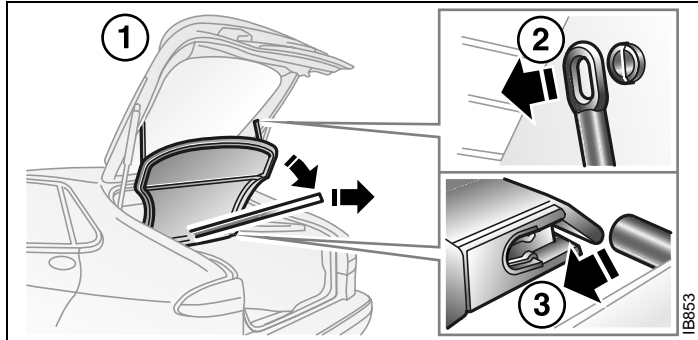

Removing the parcel shelf

- 1 Open the trunk lid.
- 2 Unhook the rubber ties.
- 3 Lift the rear parcel shelf and pull it away from the guide pins in the front edge of the shelf support.

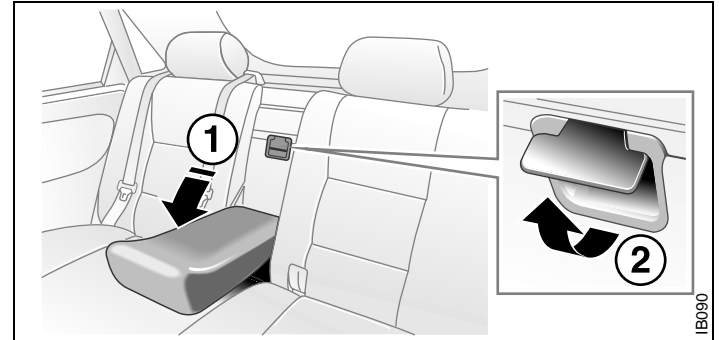

Load opening (trunk pass through)

A load opening is provided in the backrest so that you can carry long narrow objects.

Switch off the engine and set the parking brake before loading or unloading long objects. Otherwise, there is risk that you will inadvertently bump the gear/selector lever and the car could start moving.

- 1 Lower the rear armrest.
- 2 Open the cover by lifting the locking handle.

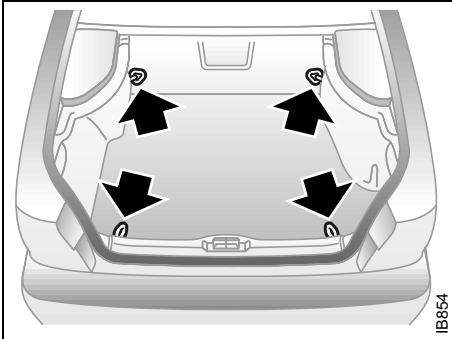

Tie downs

Four tie downs for securing the load are fitted inside the trunk. Place the load as far in as possible.

Trunk lighting

To the left in the trunk is a light which goes on and off when the trunk lid is opened and closed.

The lighting can also be turned on and off using the button on the light housing. If the trunk lid is left open, the lighting will go off after 20 minutes to prevent the battery from being drained.

WARNING

Load opening:

Always secure a load properly. You can, for example, use the hip strap in the center rear safety belt. This will reduce the risk of having the load thrown about during a collision and causing personal injury.

Trunk:

Lay heavy suitcases flat on the floor. Then place smaller and lighter items of luggage on top.

Always secure heavy, bulky loads to the four tie downs in the trunk. This will reduce risk of having them thrown about during heavy braking or during a collision and causing personal injury. When the backrest is lowered, narrow objects can also be thrown around and cause injury. You should thus secure them well.

To retain the car's safe normal handling characteristics, you must be careful not to exceed its maximum load capacity, (see page 220).

WARNING

- Never place any objects on top of the rear parcel shelf. In the event of a collision, unsecured cargo may present a safety hazard and cause personal injuries to vehicle occupants.
- Do not obstruct outward vision or the ability to exit the vehicle when loading the vehicle.
- When the rear seat backrest is placed upright after having been folded forward, ensure that all rear safety belts are accessible and properly routed.
- Make sure that tire pressures are properly adjusted in accordance with altered vehicle weight (refer to tire pressures in the Specifications section of this manual).

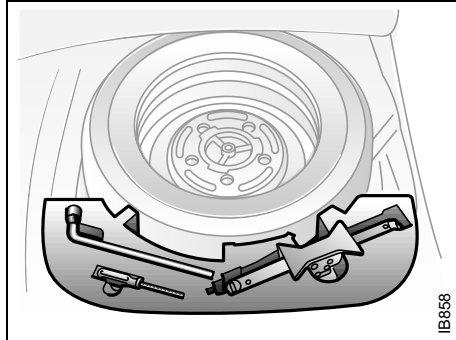

Tools and spare wheel

The tool kit and compact spare wheel are kept beneath the carpeting in the trunk.

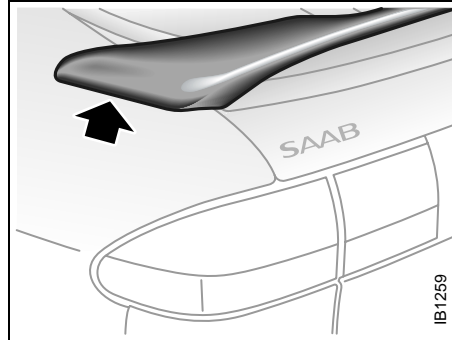

Rear spoiler, Saab 9-3 Viggen Coupé and 5-door

WARNING

Saab 9-3 Viggen Coupé and 5-door:
Avoid placing your hands on the upper part of the rear fender when the tailgate is to be closed because of the risk of getting finger caught between the spoiler and the fender.

Manually opening the fuel filler door

Coupé and 5-door models

If the fuel filler door (which is controlled by the central locking system) does not unlock, proceed as follows.

Check fuse 20. If it is blown or its replacement blows, you can release the lock motor from the door as follows:

- 1 Use a sharp knife to release the pre-cut rectangle on the right in the upholstery in the trunk so that you can access the two retaining screws that secure the lock motor to the fuel filler door.
- 2 Unscrew the retaining screws somewhat and back them out through the screw holes, whereupon the lock motor will be released from the door.

Manually opening the fuel filler door, Convertible, see page 52.

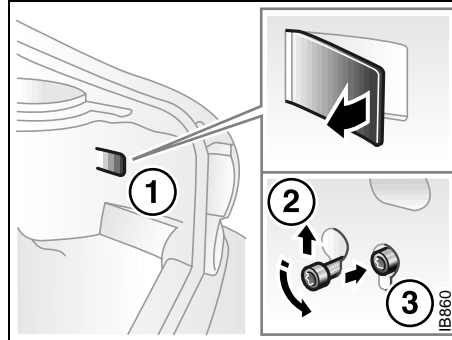

- 1 Cutout outline in the upholstery of the trunk
- 2 Undo the retaining screws of the lock motor
- 3 Remove the screws through the screw holes

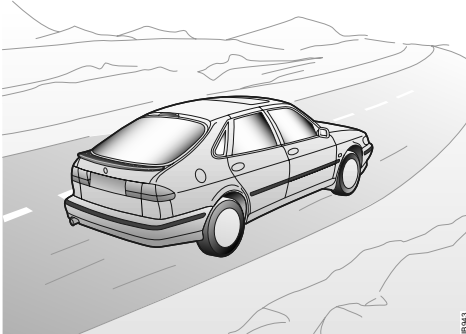

Starting and driving

Ignition switch	134	Driving in cold weather ...	154
Starting the engine.....	135	Driving in hot weather	156
Important considerations for driving.....	136	Towing a trailer	156
Engine Break-in Period...	140	Driving with a roof rack load.....	158
Gear changing	141	Towing the car.....	160
Manual transmission	141	Jump starting	162
Automatic transmission .	141	Driving considerations with compact spare wheel/tire fitted.....	165
Cruise Control	148	For long trips.....	165
Braking.....	149	Driving with the trunk lid open	166
Parking	151	Driving in deep water.....	166
Economical motoring	153		



Ignition switch

The single lock used for both the ignition and gear/selector lever is in the center console located between the front seats. Before you can remove the key, the car must be in reverse gear (manual gearbox cars) or the Parking (P) position (cars with automatic transmission).

The key for this lock also fits all other locks in the car. The key number is on a small plastic tag delivered together with the keys. Be sure to save this plastic tab since it has the key number on it.

	<p>LOCK position Put the gear lever in reverse and turn the ignition key to the LOCK position.</p> <p>For cars with automatic transmission, select the Parking (P) position and turn the ignition key to the LOCK position. The gear lever is now locked. The key can only be removed when the gear lever is in this position.</p> <p>The parking lights, the hazard warning lights and the interior lighting can still be illuminated.</p>
	<p>OFF position Gear lever is not locked (manual transmission). Automatic transmission: gear lever is locked until brake pedal is depressed.</p>
	<p>ON position The entire electrical system is operative. Do not leave the key in the ON position while the engine is not running. Turn the key to the LOCK position to disconnect the electrical system.</p> <p>When you turn the key to the ON position, the warnings and indicators in the main instrument light so that you can check to see that they are functioning properly. They are extinguished after approx. 3 seconds.</p>
	<p>Start position (ST) The starter motor operates in this position. When you release the key, it springs back to the ON position. Restarting the starter motor is prevented. If starting is unsuccessful, you must turn the key back to a position between OFF and LOCK before you can turn it to the start (ST) position again.</p>

! WARNING

- Always remove the key before leaving the car.
- Always apply the parking brake before removing the ignition key.

NOTE

Take care not to spill drinks or to drop crumbs over the ignition switch. If dirt or liquid gets into it, the switch may not operate properly.

If the car does not start

If the text "KEY NOT ACCEPTED" appears on the SID when the engine refuses to start, the trouble may be a fault in the transponder of the key or in the receiver of the ignition switch. Proceed as follows:

- Turn the key back to the LOCK position.
- Turn the key to the ON position.
- Press one of the buttons on the remote control (the LED on top of the dash stops flashing).
- Start the engine.

Try the other key. If it works, the trouble is in the first key.

Call on an authorized Saab dealer for inspection and correction.

Starting the engine**! WARNING**

- Carbon monoxide (CO) is a colorless, odorless, poisonous gas. Be alert to the danger of CO – always open the garage doors before starting the engine in the garage.
- There is also a danger of CO poisoning if the exhaust system is leaking.

Do not run the starter motor for more than 25 seconds at a time. Wait 20-30 seconds before running the starter again, to give the battery time to recover.

Avoid racing the engine or putting a heavy load on it before it has warmed up. Let the engine idle for at least 10 seconds and then drive away as long as the engine oil warning light has gone out to enable the engine to attain its normal temperature as quickly as possible.

It is possible for air to enter the lubricating system in conjunction with an oil or oil-filter change, or if the car has been stored for some time. This air can cause the hydraulic cam followers to emit a ticking noise, which can persist for up to 15 minutes after starting. Although this is quite normal and does not indicate any malfunction, it is advisable not to exceed 3,000 rpm before the noise has disappeared.

The hydraulic cam lifters are completely service free; the valve clearance is set up at the factory and will not need any subsequent adjustment.

Starting the engine

The engine has an automatic choke and should be started as follows:

Cars with manual gearbox

To start the engine the clutch pedal must be fully depressed.

- 1 Depress the clutch pedal but do not touch the accelerator.
- 2 Start the engine. Let the ignition key spring back as soon as the engine has started and is running smoothly – at very low temperatures, you may need to run the starter for up to 50 seconds.

Let the engine idle for about 10 seconds. Do not open the throttle wide for at least 2-3 minutes after starting.

Cars with automatic transmission

The selector lever must be in the P or N position.

- 1 Keep your foot on the brake pedal.
- 2 Start the engine. Let the ignition key spring back as soon as the engine has started and is running smoothly – at very low temperatures, you may need to run the starter for up to 50 seconds.

Let the engine idle for about 10 seconds. Do not open the throttle wide for at least 2-3 minutes after starting.

Useful tips on cold climate starting

If the engine has failed to start after several attempts in very cold weather, press and hold the accelerator down to the floor and run the starter for 5–10 seconds. This will prevent the engine being flooded (excessively rich fuel-air mixture).

Now start the engine in the normal way – do not touch the accelerator.

If the engine stalls immediately after starting (e.g. if the clutch was released too quickly), do not touch the accelerator when restarting the engine.

Every time the engine is switched off the spark plugs are automatically cleaned. If your attempt to start nevertheless fails, let go of the ignition key and allow it to spring back. This initiates more vigorous cleaning of the sparking plugs which goes on for about 5 seconds. Then start in the ordinary way. Do not touch the accelerator; if the accelerator is pressed to the floor the fuel supply is shut off.

Important considerations for driving

The engine-management system in the Saab 9-3 is called Saab Trionic T7. The system manages the ignition, fuel injection and turbo boost pressure.

The Trionic T7 system developed by Saab is an intelligent engine-management system designed to achieve optimum driveability under differing driving conditions. The system makes adjustments automatically, for instance, if the car is being driven at altitude (oxygen-deficient air), for different grades of fuel (AON 87–93) and for different load conditions.

1 Starting and driving

- Refrain from using full throttle before the engine has warmed up (before needle is in the mid-range on temperature gauge) to avoid unnecessary wear. If the needle of the pressure gauge repeatedly enters the red zone the engine may suddenly lose power, owing to the intervention of a monitoring system which curtails the charging pressure. Get in touch with an authorized Saab dealer at once.
- A safety function prevents the engine from revving faster than 6,200 rpm by temporarily shutting of the fuel injectors.

2 Stopping the engine

- Do not rev the engine immediately before switching it off - stop the engine when it is idling.

3 Regulating the charging pressure

- The system is optimized for fuel with an octane rating of AON 90. For cars with 205 hp engines and the Viggen, the system is optimized for AON 93. One of the advantages of the system is that it enables the engine to be run safely on lower-grade fuel, although not lower than AON 87. However, engine performance will fall off slightly, and heavy loading should be avoided. For best performance you should use the recommended grade of fuel, AON 90 (205 hp engine and Viggen AON 93).
- The maximum boost pressure is adjusted automatically to the knocking or pinging tendency of the engine. Occasional, short-lived knocking when the engine is under a heavy load is perfectly normal; the extent will depend on the grade of fuel in the tank.
- Isolated instances of knocking are more likely to occur with low-octane fuel. This controlled form of knocking, followed by a reduction in the boost pressure, is a sign that the wastegate is functioning and is perfectly safe for the engine.

Saab 9-3 Viggen: The Saab 9-3 Viggen has a high-performance engine which means that a certain amount of care should be exercised, in particular when accelerating in the lower gears. This is especially important when the road surface is slippery to avoid the driving wheels losing their grip

NOTE

If constant knocking occurs every time a load is put on the engine, this indicates a malfunction in the system.

Have the car checked without delay by an authorized Saab dealer.

NOTE

If the engine is being run with the car on a rolling road or dynamometer, longer than for a standard state emission inspection, to ensure adequate cooling, air must be blown into the engine compartment and under the car at a rate equivalent to the ram-air effect that would be obtained at the corresponding road speed.

Important considerations with catalytic converters

The catalytic converter is an emission-control device incorporated in the car's exhaust system. It consists of a metal canister with a honeycomb insert, the cells of which have walls coated in a catalytic layer (mixture of precious metals).

NOTE

Use only unleaded gasoline. Leaded gasoline is detrimental to the catalyst and oxygen sensor and will seriously impair the function of the catalytic converter.

To ensure that the catalytic converter continues to function properly, and also to avoid damage to the converter and its associated components, the following points must be observed:

- Have the car serviced regularly in accordance with the service program. The fuel and ignition systems are particularly important in this context.
- Always be alert to any misfiring of the engine (not running on all cylinders) and any loss of power or performance. At the first sign of a malfunction, reduce speed and take the car to an authorized Saab dealer as soon as possible.
- If the engine fails to start (in very cold weather or if the battery is dead), the car can be push started (manual gearbox only) or started using jumper cables to a donor battery. However, as soon as you

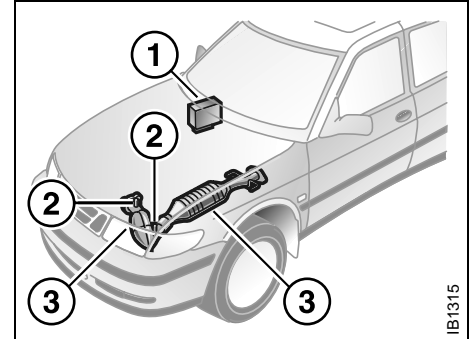

Engine-management system with catalytic converter

- 1 Engine control module
- 2 Oxygen sensor (lambda probe)
- 3 Catalytic converter

- have started the engine, it is important that it runs on all cylinders. If it is misfiring, allow it to idle for up to five minutes to give it time to settle and run smoothly. If, after this time, the engine still fails to run properly, turn off the engine and get in touch with an authorized Saab dealer for advice.
- Never park the car on dry grass or other combustible material. The catalytic converter gets very hot and could therefore start a fire.
 - Never drive off if the engine is misfiring.
 - If you jump start the car when the engine is already up to normal temperature, the engine must start to run on all cylinders.

Stop jump-starting if the engine fails to start immediately.

NOTE

If the car runs out of fuel, it is possible for air to get into the fuel system. If this happens, the catalytic converter may overheat and be damaged.

- Failure to follow these directions could result in the catalytic converter and associated components being damaged, and could represent a breach of the warranty conditions.

Refueling

Ensure that you are using the correct grade of fuel, unleaded AON 87-93. For optimum performance we recommend:

- **AON 90** for 2.0 Turbo 185 hp.
- **AON 93** for 2.0 Turbo 205 hp and 2.3 Turbo Viggen.

If fuel containing a mixture of alcohol is used, the following restrictions apply:

Methanol: max. 5% by volume.

Ethanol: max. 10% by volume.

MTBE: max. 15% by volume.

The fuel filler cap is located in the right rear quarter panel.

Switch off engine.

Insert the fuel-pump nozzle beyond the flange on the filler pipe. Do not withdraw the nozzle while filling is in progress.

Cease refuelling the first time the pump stops.

NOTE

Do not overfill. Fuel should not come right up the filler pipe as expansion room is needed.

Fuel-tank capacity: 17.0 US gal. (64 liters)

Screw on the filler cap and keep turning until it has clicked at least **three** times.

Manually opening the fuel filler door, see page 131, Convertible, page 52.

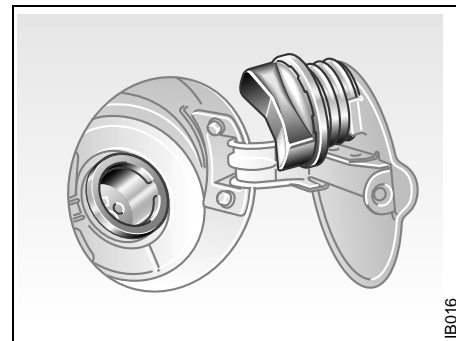

The most effective way to prevent condensation forming in the tank (and thus avoid possible running problems) is to keep the tank well filled.

Before the onset of freezing temperatures in winter, it may be advisable to add gasoline anti-freeze to the fuel a few times to dispel any condensation in the system.

⚠ WARNING

- Never use fuel for any purpose other than as engine fuel.
- Gasoline is highly flammable and can cause severe burns. Never use an exposed flame in the vicinity of gasoline. Never smoke when filling the vehicle up with gasoline.

NOTE

- Fill to maximum filling capacity
- Stop filling after the first time that the nozzle trips to shut off the flow of fuel
- Filling capacity can differ between different fuel stations and outside temperature. Fuel tank volume when nozzle trips to shut off, may vary by 0.5 gal. (2 liters).
- Do not fill fuel all the way up the filler pipe. The gasoline must be allowed room for expansion especially during hot weather.

Recommended fuel:

The engine in your Saab 9-3 is designed to operate on unleaded gasoline that has an octane rating of:

- AON 90 (minimum 87) for 185 hp engines.
- AON 93 (minimum 87) for 205 hp engines and Viggen.

Octane rating is determined according to the formula:

$$\frac{\text{MON} + \text{RON}}{2}$$

where MON is the Motor Octane Number, and RON is the Research Octane Number.

The average of these two values is the octane rating of the gasoline as it appears on the pump at a retail gas station. This value is sometimes referred to as the "Anti-Knock Index" (AKI) or the "Average Octane Number" (AON).

To avoid deposit formation on the fuel injectors which can cause poor driveability, use only quality gasolines that contain detergents and corrosion inhibitors. Because gasolines sold at retail gas stations vary in their composition and quality, you should switch to a different brand if you begin experiencing driveability and/or hard starting problems shortly after refueling your car. In recent years, a variety of fuel additives and alcohols or oxygenates have been blended with gasoline. These types of gasolines may

be found in all parts of the United States and Canada, but particularly in geographic areas and cities that have high carbon monoxide levels. Saab approves the use of such "reformulated" gasolines in its products, which help in reducing pollution from all motor vehicles, provided that the following blending percentages are met by such fuels:

- Up to 10% ethanol by volume, with corrosion inhibitors.
- Up to 15% MTBE by volume (methyl tertiary butyl ether).
- Up to 5% methanol by volume, with an equal amount of a suitable co-solvent and added corrosion inhibitors.

Other, less common, fuel additives used by some gasoline dealers are also acceptable, provided that the resultant gasoline is not more than 2.7% oxygen by weight. In many cases, you may not be able to determine the exact type or percentage by volume of fuel additive in the gasoline you purchase for your car.

Some Canadian and U.S. gasolines contain an octane enhancing additive called methylcyclopentadienyl manganese tricarbonyl (MMT). If such fuel is used, your emission control system performance may deteriorate and the malfunction indicator lamp on your instrument panel may turn on. If this occurs, return to your authorized Saab dealer for service.

However, these blended gasolines are regulated and should never exceed these rec-

ommended blend percentages and service station operators should know if their gasolines contain detergents and oxygenates, and have been reformulated to reduce vehicle emissions. Nevertheless, if you begin to notice a problem with the way your car starts or runs shortly after it has been refueled, try a different brand of gasoline.

NOTE

Higher concentrations of methanol than listed above, or the use of methanol-blended gasoline without suitable co-solvents and corrosion inhibitors, can damage your car's fuel system, leading to the need for repairs which are not covered by Saab's product warranty.

NOTE

The engine control module (ECM) monitoring the engine parameters also stores fault codes.

Under certain circumstances, this may cause constant illumination of the Engine malfunction (CHECK ENGINE)

lamp , thus indicating a fault that must be checked by your Saab dealer, see page 57.

NOTE: always observe the following two measures:

- Make sure that the fuel filler cap is screwed on correctly before the engine is started. Screw on the fuel filler cap until you hear three distinct clicks.
- Avoid driving with the fuel low level indicator illuminated. The symbol illuminates when less than approximately 2.5 gallons (10 litres) of fuel remains in the tank.

Engine Break-in Period

Pistons, cylinder bores and bearings need time to obtain uniform, wear-resistant surfaces.

If a new engine is driven too hard, this gradual process of bedding-in will not be possible and the life of the engine will be shortened.

During the first 1,200 miles (2,000 km), do not exceed 5,000 rpm.

In addition, refrain from driving the car at full throttle, other than for brief instances, during the first 1,800 miles (3,000 km).

Wearing in new brake pads

New brake pads take time to bed in, about 90 miles (150 km) if the car is driven largely under stop-and-go conditions or about 300 miles (500 km) of highway driving.

To extend the useful life of the pads, avoid hard braking as much as possible.

Wear indicators

The outer brake pads on the front wheels have acoustic wear indicators. When 3 mm remain on the pads, a scraping or shrieking noise is heard on braking. When this occurs, the pads should be changed as soon as possible.

Changing brake pads should only be carried out by an authorized Saab dealer.

Gear changing

Manual transmission

To start the engine the clutch pedal must be fully depressed.

The gear positions are marked on the gear lever. Before reverse (R) can be engaged, you must lift the ring underneath the gear-lever knob.

To change gear, fully depress the clutch pedal and then release it smoothly. It is inadvisable to drive with your hand resting on the gear lever, as this can increase the wear on the gearbox.

When shifting down from 5th to 4th gear, ease the gear lever straight back, without applying any lateral pressure. This will prevent 2nd gear being engaged by mistake, which can result in overrevving and possible damage to the engine.

NOTE

When the reverse gear is to be engaged the car must be at a standstill with the accelerator fully released. Lift the reverse lock-out collar and push the gear lever firmly to the right in neutral before easing it into reverse.

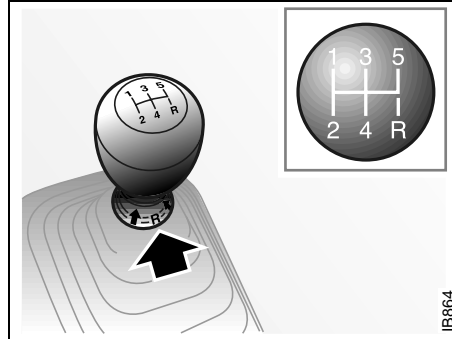

Shift-up indicator for improved fuel economy (U.S. models only)

Cars equipped with a manual transmission have a "Shift-up" light on the instrument panel. The light begins to work after the vehicle is warmed up and provides you with a good indication when to shift to a higher gear.

It is not necessary or recommended to follow the shift-up recommendations in all driving conditions, for example, when driving in heavy urban traffic or steep downhill grades.

However, shifting with the light should result in improved fuel economy. Therefore, for reduced fuel consumption and better energy conservation, you should make a habit of shifting before or when the shift-up light comes on.

Automatic transmission

⚠ WARNING

- Make it a habit to keep your foot on the brake when selecting a drive position, to prevent the car from creeping forward (or backwards if reverse is selected).
- The car must be at a standstill before P, R or N is selected. You have to have your foot on the brake pedal to move the lever out of park. If the car is still moving when a drive position is subsequently selected, this could cause an accident or damage the automatic transmission.
- Never park the car with the selector lever in a drive position, even if the parking brake is on.
- If you want to leave the car with the engine running, move the selector lever to P or N and apply the parking brake.

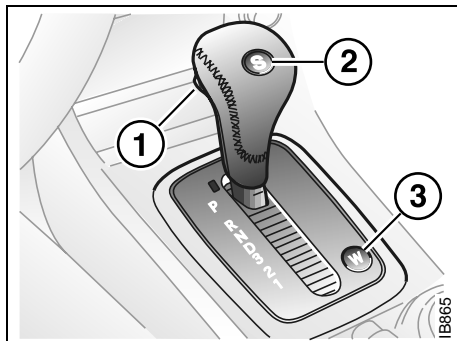

Selector lever

- 1 Catch
- 2 Button for SPORT position
- 3 Button for WINTER position

The electronic control module for the automatic transmission receives information on engine torque and road speed. It also controls the hydraulic pressure in the transmission to ensure that gear changing is as smooth as possible.

The position of the selector lever is shown by the symbols adjacent to the lever and also by an indicator on the main instrument panel.

The ignition key can only be removed when the selector lever is in the P position.

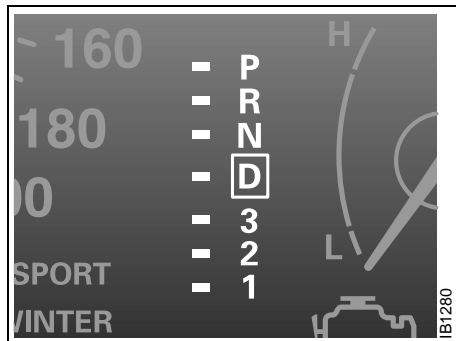

Indication of gear position on the main instrument panel

When the car is stationary, the engine must be idling when the selector lever is moved. **You must have your foot on the brake pedal to move the lever out of park.** If the accelerator is depressed while the lever is moved, this will result in abnormal wear in the transmission.

NOTE

After selecting a drive position, pause briefly to allow the gear to engage (the car starts to pull a little) before you accelerate.

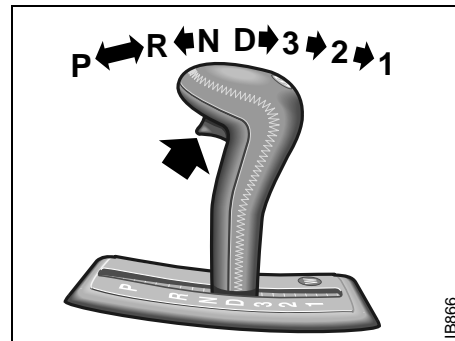

Detent positions for selector movement

The detent button on the selector lever has to be pressed before the selector can be moved between certain positions.

Three modes for the automatic transmission can be selected: Normal, Sport and Winter.

The Normal mode, which provides the best fuel economy, is the default setting when the engine is started.

Sport mode alters the angle of the throttle valve for increased power compared to the same accelerator position in Normal mode. This means gear changes are made to optimize the car's performance. The SPORT indicator light is shown on the main instrument panel; see page 147).

The Winter mode is intended for use when pulling away and driving on icy roads. In this mode, the transmission starts in 3rd gear, to

provide better grip, and the WINTER indicator appears on the main instrument panel. When the ignition is turned to OFF, the automatic transmission will automatically revert to Normal mode (see page 147).

Adaptive gear change pattern is a function of the Normal and Sport modes. It allows gear changing to be suited to the prevailing driving conditions. The transmission control module senses the engine load and temperature of the transmission and selects one of the four available gear change patterns. Unnecessary gear changes and undesired temperature increases in the transmission are avoided.

The automatic transmission has a special shift pattern during the first minute after a cold engine is started so that the catalytic converter will reach its correct working temperature more rapidly

Lock-up function

The automatic transmission has a lock-up function, which renders the torque converter inoperative in 2nd, 3rd and 4th gears. The result is reduction in the engine speed and, hence, fuel consumption.

When the lock-up function comes into operation, it may give the impression of an overdrive being engaged.

Shift Lock override

NOTE

Due to electrical problems it may not be possible to move the selector out of the park position, even if the ignition is ON. If for some reason the selector has to be moved out of the park position (i.e. to tow the car a short distance) do as described below.

- 1 Apply the parking brake.
- 2 Make sure the key is in the ON position.
- 3 Use a small tool such as a screwdriver and push the lever downwards so that the detent button can be pressed approx. 10 mm.
- 4 Move the selector out of position P to N.
- 5 Remove the tool.
- 6 Release the parking brake if the car is to be moved immediately; otherwise keep it applied.

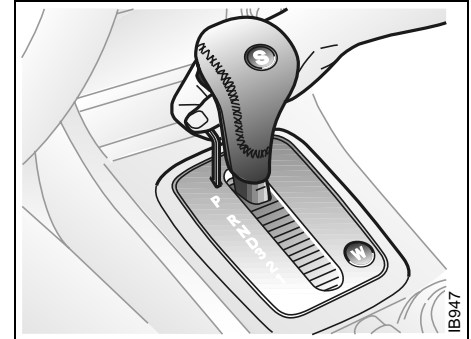

Check fuse No. 1 (see page 189). If the fuse is OK, check the battery voltage.

If the problem was cured by changing the fuse or battery, you do not have to contact a Saab dealer.

If the fuse blows again as soon as the Shift Lock feature is activated you should contact your Saab dealer.



Automatic transmission fault indicator

If the symbol appears on the main instrument panel, the system has detected a fault in the automatic transmission or its control module (see page 58).

This also means that the Limp-home mode has been selected, to guard against further damage being done to the transmission. In this mode, the automatic transmission starts in 4th gear, and gear changes (if necessary) will have to be made manually.

It is not possible to select the SPORT or WINTER mode when the Limp-home mode is active.

You should have the automatic transmission checked as soon as possible by an authorized Saab dealer.

The following gears will be engaged in the respective selector positions when the automatic transmission is in the Limp-home mode:

Position	R	D	3	2	1
Gear	Reverse	4th	4th	3rd	3rd

NOTE

If the control module has actuated the Limp-home function for the automatic transmission, the car will remain in 4th gear when D is selected, making it very sluggish. To overcome this, move the selector lever to position 2.

Overheated transmission oil

If the transmission oil becomes overheated while driving, the following message appears on the SID: TRANSMISSION OVERHEATING. In this event, stop the car in a suitable place, switch off the engine, open the hood and wait until the message goes out. When driving subsequent to the transmission oil overheating, select a locked gear position in which the engine speed is about 3,000 rpm.

The transmission oil can become very hot when the car is driven with a heavy load; for example, driving with a trailer on hilly roads when the wrong gear has been selected, resulting in many extra gear changes. Select one of the positions 1, 2 or 3. A high outside temperature or a defective oil cooler can also cause the oil temperature to increase. Contact an authorized Saab workshop, see also page 156.

Driving in hilly country with a heavy load

Overheating of the automatic-transmission fluid can occur when the car is towing a heavy load, such as a trailer in hilly country, with the wrong gear selected, resulting in abnormally frequent gear changing. Try selecting position 1, 2 or 3. High ambient temperatures can also increase the temperature of the transmission fluid or the oil cooler may be faulty. As the transmission fluid temperature increases, its useful service life is reduced. Contact an authorized Saab dealer (see also page 156).



WARNING



Remember to use engine-braking (selector position 1, 2, or 3) to spare the brakes when you are driving on a long or steep downhill slope. Select the same gear as you would on the corresponding uphill slope.



Brake failure can result from overheated brakes!

Towing

Towing a car with automatic transmission, see page 162.

Selector positions

	<p>P To shift out of the P position you must depress the brake pedal and the ignition must be ON. The parking position (P) must only be selected when the car is at a complete standstill. The selector lever is locked and the transmission is mechanically immobilized. Always apply the parking brake after parking the car. The engine can be started.</p>
	<p>R The reverse (R) position must only be selected when the car is at a complete standstill. The detent-release button must be pressed before the selector lever can be moved to R. Wait until reverse gear has engaged (car starts to creep) before touching the accelerator.</p>
	<p>N In the Neutral position (N), the transmission is disengaged from the engine. The engine can be started, but first ensure that the parking brake is on, to prevent the car from moving off unexpectedly. To prevent the engine and transmission from becoming hotter than necessary, select N for stops other than brief ones, e.g. if stuck in a traffic jam. The normal drive position (D) is recommended for waiting at traffic lights.</p>

	<p>D The Drive position (D) is the position for normal motoring. Gear changes between 1st and 4th will take place automatically, the timing of which is determined by the throttle (accelerator) position and the speed of the car. After moving the selector lever to D, pause to give the gear time to engage (car starts to pull).</p>
	<p>3 In position 3, 4th gear is locked out. The car will start in 1st gear and normal gear changing (up and down) will take place automatically between gears 1, 2 and 3. Position 3 is recommended on roads with frequent bends and in congested traffic. Moving the selector lever from D to 3 will cause a downshift to 3rd gear, which will give better engine-braking. Do not move the selector to position 3 at speeds in excess of 90 mph (150 km/h).</p>
	<p>2 Position 2 is recommended in hilly country. This gear enables the performance of the engine to be exploited better and also provides effective engine-braking. Normal gear changing (up and down) between 1st and 2nd gear will take place automatically. Third and 4th gears are locked out. Do not move the selector to position 2 at speeds in excess of 70 mph (110 km/h).</p>

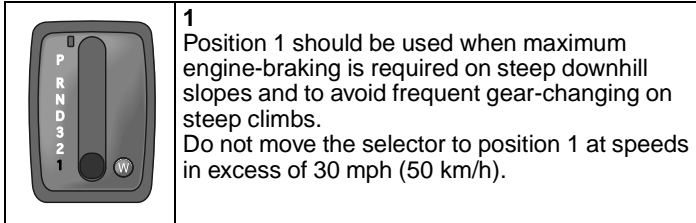

If the gear selector lever is moved from position D to 1, a change-down to 3rd gear will occur at about 110 mph (180 km/h). A change-down to 2nd gear will occur at about 75 mph (120 km/h) and to 1st gear at about 40 mph (65 km/h).

When position 1 is selected, all the other gears will be locked out. Manual gear-changing is not recommended on slippery roads.

2.0 Turbo 185 hp and 205 hp: If one of the drive wheels spins excessively, the engine torque will be reduced to avoid damaging the transmission

Kick-down

When the accelerator is pressed down hard, a downshift to the next lower gear will occur to provide maximum acceleration, e.g. for overtaking.

The change-up to the next gear again will take place either when the accelerator is released or when maximum engine speed for that gear is reached.

Adaptive gear-change patterns

Adaptive gear-change patterns are selected automatically depending on the engine load. This function applies in the Normal and Sport modes.

The change occurs at a higher rotation speed and the gear remains engaged for a longer period, if the control module senses that the load does not drop. These change patterns avoid unnecessary gear changes when, for example, driving on long inclines with a trailer, and to prevent overheating of the transmission oil. This function cuts in automatically if the oil becomes too hot, to protect the transmission from serious damage, and lower the oil temperature.

The adaptive change pattern function is not activated at speeds over 93 mph (150 km/h). If a pattern is in operation when this speed is exceeded, it will be maintained until the control module senses that a more suitable one can be activated.

The adaptive gear-change pattern function is deselected when:

- Winter mode is selected.
- The engine is switched off.
- The load is reduced by so much that this function is no longer required.
-  "Automatic transmission fault indicator" appears on the main instrument panel, see page 144.

The SPORT and WINTER modes



To select Sport mode, press the "S" button on the selector lever when the selector lever is in position N, D, 3, 2 or 1.

In this mode, gear changes will take place at higher engine speeds than in Normal mode, in other words, the transmission will shift up later and shift down earlier for the same throttle (accelerator) position.

The Sport mode will be deselected if:

- The S button is pressed.
- The selector lever is moved to position P or R.
- The engine is switched off.
- The Winter mode is selected.
-  "Automatic transmission fault indicator" appears on main instrument panel, see page 144.



The Winter mode facilitates starting off and driving on icy roads. Third gear is selected automatically for starting off to reduce wheelspin.

Winter mode can be selected when the engine is running by pressing the "W" button on the selector-lever surround. It cannot be selected when the selector lever is in position 2 or 1.

Note: It is still possible to use kick-down in the Winter mode, in which case a change-down to 2nd or 1st will take place.

The Winter mode will be deselected if:

- The W button is pressed.
- The engine is switched off.
- The selector lever is moved to position 2 or 1.
- Kick-down is activated.
- The automatic-transmission fluid overheats.
-  "Automatic transmission fault indicator" appears on main instrument panel, see page 144.

Cruise Control

! WARNING

- Do not use the Cruise-control system on wet or icy roads, in dense traffic or on winding roads
- To prevent the system being activated inadvertently, set the control to OFF when you do not want to use the system

The system is operated by means of the controls on the stalk switch:

- OFF (system is disconnected; the system is always in the OFF position when the engine is started).
- ON (system switched on).
- SET/+ (to set the desired speed).
- CANCEL (cancel operation of system, e.g. to reduce speed temporarily).
- RES/- (resume preset speed).

When the system is ON, the CRUISE indicator light will appear on the main instrument panel and will be extinguished when the system is switched OFF. If CANCEL is selected, CRUISE will flash off once.

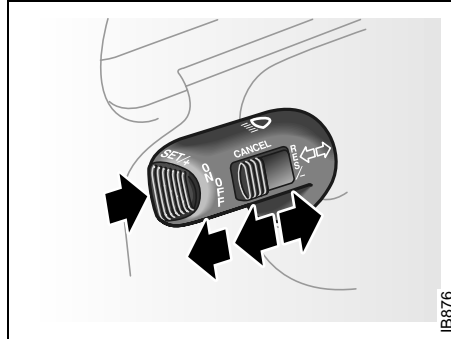

To set the desired speed

Move the switch to ON. Accelerate to the desired speed (minimum speed: 25 mph (40 km/h) and press SET/+.

To increase the preset speed

Accelerate to the desired speed and press SET/+.

You can also increase the speed of the car using the SET/+ button. Press it once to increase the speed by 1 mph (1.6 km/h) or hold it in and release when the desired speed is reached.

Temporary increase in speed

Press the accelerator to override the preset speed, e.g. for overtaking.

When you release the accelerator, the system will revert to the preset speed.

To cancel temporarily

Move the control stalk to CANCEL (spring-loaded position before OFF position). This will disengage the system but the preset speed will be retained in the system memory. (The memory is deleted when the engine is switched off.)

To re-engage the system

To revert to the preset speed, slide the switch to RES/-. This will only operate when the car's speed is above 25 mph (40 km/h).

To reduce the preset speed

The cruise-control system will always disengage automatically the moment that either the brake pedal or the clutch pedal is depressed.

It is also possible to reduce the speed by:

- Sliding the button to RES/- once will reduce the speed by 1 mph (1.6 km/h).
- Holding the button in the RES/- position will effect a gradual reduction in speed until the button is released.

Disengaging the system

The system will be disengaged:

- When the brake or clutch pedal is depressed.
- When the switch is moved to CANCEL.
- When the switch is moved to OFF.
- When the engine is switched off.
- When the selector lever is moved to position N (cars with automatic transmission).

Braking

To avoid overheating the brakes, (e.g. when negotiating long descents with a drop of several hundred feet), select a low gear to use the braking effect of the engine. If the car has automatic transmission, move the selector lever to position 1 or 2.

When driving fast, you can help to prolong the life of the brakes by thinking ahead and braking harder for short periods, rather than braking more moderately over long stretches.

Brake pad wear indicators

The outboard brake pads on the front wheels incorporate pad-wear indicators. When the lining is down to 3 mm, the pad will produce a screeching, squealing or scraping noise when the brakes are applied. New pads should be installed without delay.

Brake pads should only be replaced by an authorized Saab dealer.

To ensure optimum brake performance, it is recommended that you use only Saab original brake pads.

WARNING

- It is prudent to try your brakes from time to time, especially when driving in heavy rain, on roads with a lot of surface water, or in snow or slush. In such conditions, the brakes may take longer than normal to take effect. To rectify this, touch the brake pedal periodically to dry the brakes out.
- The same applies after the car has been washed or when the weather is very humid.
- The brakes are power assisted and it should be kept in mind that the servo unit only provides the power assistance when the engine is running.
- The brake pressure required when the engine is off, (e.g. when the car is being towed) is roughly four times the normal pedal force required. The pedal also feels hard and unresponsive.

ABS brakes

! WARNING

- The additional safety afforded by the ABS system is not designed to allow drivers to drive faster but to make normal driving safer.
- To stop as quickly as possible, without loss of directional stability, whether the road surface is dry, wet or slippery, **press the brake pedal down hard without letting up (do not pump the pedal), declutching simultaneously, and steer the car to safety.**

ABS (Antilock Braking System) modulates the brake pressure to the respective wheels. Wheel sensors detect if a wheel is about to lock, and the control module reduces the pressure to that wheel and then increases it once more until the tendency is detected again.

The brake system is equipped with an Electronic Brake-force Distribution device (EBD), which distributes the brake pressure between the front and rear wheels in such a way as to achieve optimum braking performance regardless of the car's speed and load.

The ABS system has a built-in diagnostic function which will switch on the ABS warning light if a fault is detected in the system (see page 56).

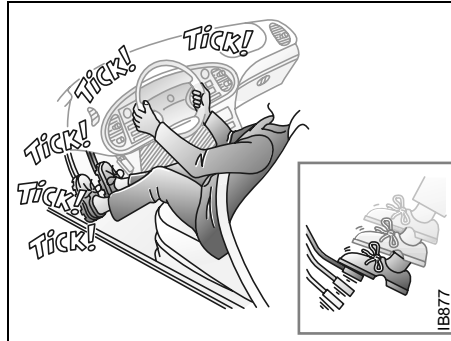

ABS braking - confirmation that the system is operating



Braking with ABS - evasive steering

The ABS system will not reduce the braking distance on loose gravel or on snow or ice but, because the wheels cannot lock up, some steering control is retained.

When the ABS system is working, i.e. modulation of the brake pressure is in progress, the brake pedal will pulsate and a ticking noise will be heard. All this is perfectly normal.

Press the pedal **down hard** (you cannot press too hard) and steer the car to safety.

Do not release the brake pedal before the car has come to a halt or the danger is past!

This is critical.

If the road is slippery, the ABS system will operate even when only light pressure is applied to the pedal. This means that you can brake gently to test the condition of the road and adapt your driving accordingly.

It is well worth practising the use of ABS brakes on a skid pad or other suitable facility.

Parking brake

The parking brake lever is located between the front seats. The brake acts on the rear wheels. When the parking brake is on, the indicator lamp on the main instrument panel will be lit.

To release the brake, lift the lever slightly, press the pawl button, and let the lever drop down. Always apply the parking brake when you park.

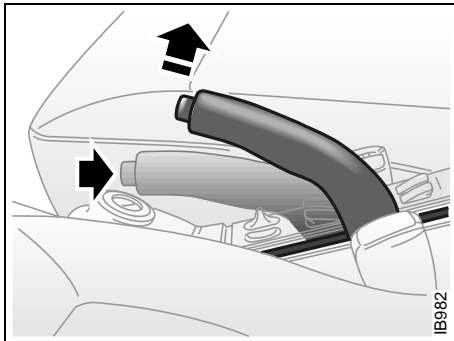

Parking

! WARNING

- Park where the vehicle will not create an obstruction or a hazard to other road users.
- Do not park on dry grass or other combustible material. The catalytic converter gets very hot and could start a fire.
- Do not leave children or pets unattended in the car. In warm, sunny weather, the temperature inside the car can reach 160–180°F (70–80°C).

NOTE

- Apply the parking brake.
- Shift into Reverse for manual transmission; for automatic transmission: move selector lever to P (Park), and remove the ignition key.
- Lock the car.

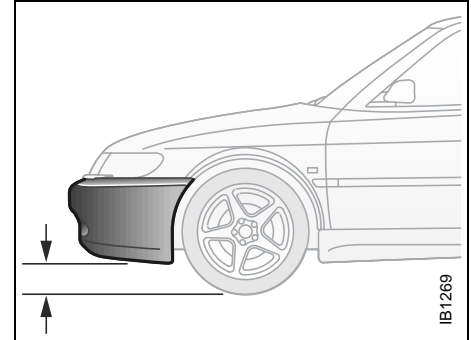

NOTE

Saab 9-3 Viggen: The body design together with the relatively low ground clearance of the car means that great care must be taken during parking to avoid damage to the under part of the bumper.

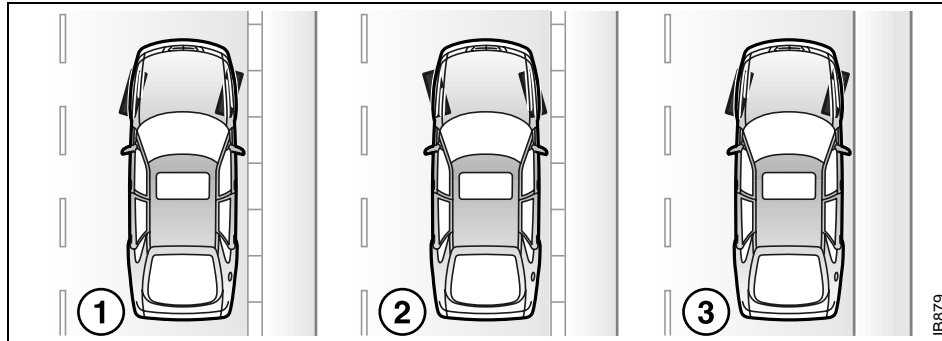

1 Pointing downhill and against the curb

– Turn the wheels into the curb and edge the car forward until the wheels touch the curb.

2 Pointing uphill and against the curb

– Turn the wheels away from the curb and edge the car back until the wheels touch the curb.

3 Pointing uphill or downhill – no curb

– Turn the wheels towards the edge of the road. If the car should start rolling, it will not run into the road.

Parking on a hill

When parking on a steep hill, turn the front wheels so that they will be blocked by the curb if the car should move.

Long-term parking

If the car is not going to be used for some time, e.g. 3–4 months, the following steps are recommended:

- Run the engine to normal temperature before long-term parking.
- Drain the washer-fluid reservoir and hoses.

- Wash and wax the car. Clean the rubber seals on the hood, trunk lid and doors, and lubricate them with glycerol (glycerin).
- After washing the car, dry the brake discs by taking the car out on the road and applying the brakes a few times.
- Fill the fuel tank with fuel to prevent condensation forming in it.
- Top up the coolant and check the anti-freeze before the onset of winter.
- Park the car in a dry, covered and well-ventilated building. Leave the parking brake OFF!
- Disconnect the negative (-) battery lead. If freezing temperatures are likely to occur during the long-term parking, remove the battery and store it away from freezing temperatures.
- Ideally, the car should be put up on blocks, with the wheels off the ground. If this is not possible, inflate the tires to about 43 psi (300 kPa).
- Leave all the windows open a crack and cover the car with a fabric tarpaulin - not one made of plastic which will not breath.

Economical motoring

Factors affecting fuel consumption

Fuel consumption is greatly affected by the general driving conditions, the way in which the car is driven and at what speeds, the weather, the state of the road, the condition of the car, etc.

Breaking-in

Fuel consumption may be somewhat higher during the break-in period (the first 3,000–4,000 miles (5,000–7,000 km) than stated under "Technical data".

Weather conditions

Fuel consumption can be as much as 10 % lower in summer than in winter. The higher consumption in cold weather is explained by the longer time it takes for the engine to reach normal operating temperature, and for the transmission and wheel bearings to warm up. Fuel economy is also affected by the distance driven: short journeys of 3-5 miles (5-8 km) do not give the engine enough time to reach normal temperature. Strong winds can also affect fuel consumption.

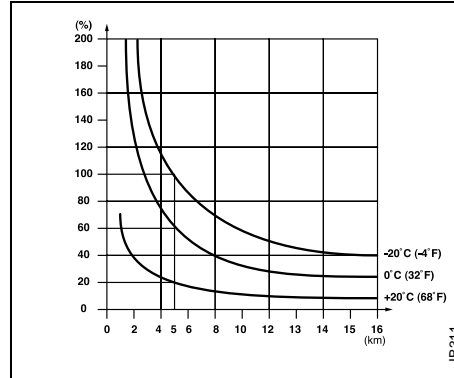

Percentage increase in fuel consumption of engine starting from cold compared to engine at normal temperature

How to read the graph:

If fuel consumption with the engine at normal temperature is 28 mpg (10l/100 km), the actual fuel consumption 3 miles (5 km) after the engine has started from cold will be:

- 23.5 mpg (12l/100 km) at outside temp. of 68°F (20°C) (increase of 20%)
- 17.7 mpg (16l/100 km) at outside temp. of 32°F (0°C) (increase of 60%)
- 14 mpg (20l/100 km) at outside temp. of -4°F (-20°C) (increase of 100%)

As can be seen, both the distance travelled by the car and the outside temperature have a major impact on fuel consumption after

the engine has started from cold. Thus, if the car is mainly used for short journeys of 3–5 miles (5–8 km), the fuel consumption will be 60–80 % higher than normal.

Driving technique

- To obtain the best running economy, not only regarding fuel consumption but general wear also, regular service is required.
- High speed, unnecessary acceleration, heavy braking and much low gear work all gives rise to higher fuel consumption.
- Frequent gear changing in traffic, starting in cold weather, the use of studded tires and roof racks, and towing a trailer all increase fuel consumption.
- Do not run the engine when the car is stationary. If idling, it will take much longer before the engine becomes hot. Engine wear is greatest during this warming-up phase. Therefore drive away as soon as possible after the engine is started and avoid high revving.

- Driving in a low gear results in higher fuel consumption than in a high gear because of the lower engine speed for a given road speed. Always change up to a higher gear as soon as traffic conditions allow and use the highest gear as much as possible.
- Check the air pressure in the tires once a month. Incorrect pressures increase tire wear. It is better to have slightly higher pressure than lower.
- Check fuel consumption regularly. Increased consumption can indicate that something is wrong and that the car needs to be checked by an authorized Saab dealer.

Practical tests on the roads have demonstrated that substantial savings in fuel consumption can be made if the above advice is heeded.

Road conditions

Wet roads increase fuel consumption, as do unpaved roads and driving in hilly country (the amount of fuel saved driving downhill is less than the additional amount required to climb the hill).

Engine block heater (standard equipment in Canada, accessory in U.S.)

The following are just some of the benefits to the car and the environment of using an engine block heater:

- Lower fuel consumption.
- Reduced wear on the engine.
- Inside of car warms up faster.
- Exhaust emissions substantially reduced over short runs.

The engine block heater is effective with outside temperatures up to +60 – +70°F (+15 – +20°C). The warmer it is outside, the shorter the time the heater need be connected. Longer than 1.5 hours is unnecessary.

If the car is equipped with a removable electrical cabin heater that is not in use, this should be stored in the luggage compartment.

Driving in cold weather

Before starting a journey in cold weather you should check the following:

- That the wiper blades have not become frozen to the windshield/glass.
- Brush any snow away from the air intake for the heater system (opening between hood and windshield).
- It may be advisable to lubricate the door-lock cylinder (use molybdenum disulphide, MoS₂) to prevent its freezing. If the lock has frozen, take care not to break the key (or use the remote control) – heat it first or spray it with de-icer.
- Periodically during the winter, add gasoline anti-freeze to the fuel to dispel any condensation in the fuel tank which could freeze and cause problems in the system. Keep the tank well filled to reduce the risk of condensation forming. If the car is parked outside in freezing weather, fuel additives (gasoline anti-freeze) will not do any good as it cannot remove water that has already frozen. Park the car in a warm place so that any ice that may have built up melts, then add gasoline anti-freeze when filling up the tank. Condensation is caused by changes in the outdoor temperature or by the car being parked alternately in a garage and outside.
- It is particularly important when the roads are slippery that the brakes and tires be in good condition.

- Check the anti-freeze in the engine coolant, see page 174.

The car's trip computer will warn you when there is a risk of slippery conditions. For further information on this function, see page 62.

The car is equipped with tires designed to provide optimum grip on both wet and dry roads, although this has been achieved at the expense of somewhat reduced grip on snow and ice. For regular driving on snow and ice, we therefore recommend that winter (snow) tires be fitted.

Winter (snow) tires, particularly studded tires (where use is legally permitted), generally make driving safer on snow and ice.

Acquaint yourself with the legal provisions governing the use of different types of winter tires and snow chains. Studded tires are not allowed in some countries.

If winter tires are installed, the same type must be installed on all wheels. Your Saab dealer will be pleased to advise you on the best tires for your car.

Remember that tires age. It may therefore be necessary to change them before they reach the legal wear limit, as they gradually lose their friction properties.

The best response if the car gets into a front-wheel skid is to freewheel (manual gearbox only), i.e. disengage the clutch (so that the wheels are neither driven nor braked by the engine) and carefully steer the wheels in the direction you want to go.

If the car has an automatic transmission you should lift off the accelerator somewhat and carefully steer the wheels in the direction you want to go.

In a rear-wheel skid, steer into the skid, i.e. in the same direction as that in which the back is sliding.

Tire chains

If you want to fit tire chains (where legally permitted) they should only be installed to the tires recommended under "Technical data" (see page 227).

Consult your Saab dealer for details about approved tire chains.

WARNING

- Do not exceed 30 mph (50 km/h) when tire chains are fitted.
- Tire chains can reduce the directional stability of the car.
- Tire chains must not be used on the rear wheels.

NOTE

- Check the links frequently for wear.
- Check that the chains do not contact the wheel-arch liner at full lock.
- See section "Technical data", page 227, for information on allowable wheel dimensions for the fitting of tire chains.

Driving in hot weather

- Always check the coolant level before starting a journey. When the engine is cold, the coolant must not be above the KALT/COLD mark on the expansion tank.
- At the end of a journey, if the engine has worked hard, allow it to idle for two or three minutes before switching it off.

If the needle on the temperature gauge enters the red zone:

- 1 Bring the car to a standstill but leave the engine running. Do **not** remove the cap on the expansion tank even if the tank is empty. The engine temperature should decrease. If the temperature continues to rise with the engine idling, the engine must be switched off.

- 2 If the engine is idling and the needle on the temperature gauge falls, wait until a normal temperature is shown (about in the middle of the scale) before switching off the engine. If the coolant needs topping up, unscrew the cap on expansion tank **carefully**.

Top up, as necessary, ideally with a 50/50 mixture of coolant and water. Use a Saab-approved coolant. If only water is available, use that, but remember to have the coolant mixture checked as soon as possible.



WARNING

Always undo the expansion tank filler cap carefully, releasing the pressure and any vapor before removing the cap completely.

- 3 As soon as possible, have the cooling system checked by an authorized Saab dealer.

Towing a trailer

Trailer hitch attachment

Trailer hitch attachments are available as accessories. These are designed for a maximum trailer weight of 2000 lbs (900 kg), see also page 222.

Use only the electrical trailer hitch socket provided in the trailer hitch kit.

Saab recommends:

- Use a Saab original hitch kit attachment which is designed and tested by Saab.
- Consult your Saab dealer as regards the right hitch kit for your car.

NOTE

Use only a genuine Saab trailer hitch and wiring, since other wiring methods can cause expensive damage to the car's body and electrical system.

Consult an authorized Saab dealer for guidance on how to connect the trailer hitch electrical system.

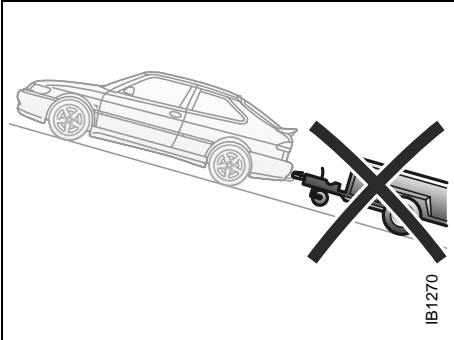

NOTE
Saab 9-3 Viggen cannot be equipped with a trailer hitch because of the design of the body and chassis.

Trailer weight

Maximum recommended trailer weights for different gradients, for best comfort and driveability for manual and automatic cars, are shown in the drawing.

Make sure you are familiar with the law regarding speed limits for towing, maximum trailer weights, trailer-braking requirements, and also any special driving-license provisions (see also page 222).

⚠ WARNING

When towing a trailer, do not attempt to negotiate a hill having a gradient in excess of 15%. The weight distribution over the front wheels of the car will be insufficient to prevent wheelspin, making further progress impossible.

In addition, the parking brake may not always be able to hold the car and trailer securely, with the result that the wheels can start to slide downhill.

The specified trailer weights and gradients assume you are operating in hilly terrain and therefore apply only to short trips.

Recommendations for cars with automatic transmission

The following time limits are based on the capacity of the cooling system in warm weather, i.e. approximately 86°F (30°C).

Gradient of hill, %	Maximum trailer weight, lbs. (kg)	Maximum duration, minutes
10-15	1890 (850)	15 max.

The following time limits are based on the capacity of the cooling system in warm weather, i.e. approximately 104°F (40°C).

Gradient of hill, %	Maximum trailer weight, lbs. (kg)	Maximum duration, minutes
10-15	1110 (500)	15 max.

When negotiating long hills, bear the following important considerations in mind:
Do not drive continuously with the WINTER mode selected in hilly country when you are towing a trailer, as this will increase fuel consumption and risk overheating the transmission.

Trailer hitch load

The weight distribution on the trailer makes a lot of difference to the handling properties of the car and trailer combination. With single-axle trailers, whenever possible, concentrate the load over the axle and keep it as low as possible.

The trailer should be loaded so that the maximum load on the towbar ball is 5% to 7% of the trailer weight with a maximum permissible tongue weight of 165 lbs (75 kg).

Note that this load must be added to the total load for the car. If this now exceeds the specified load capacity, the load in the trunk will have to be reduced by a corresponding amount.

Driving considerations

Always take extra care when towing a trailer, as the car's handling will be different and its braking effect reduced. The trailer's braking system and suspension also have a considerable effect on these characteristics, see also "Driving with a load" page 160.

If the car is equipped with automatic transmission, select position 1 when ascending or descending steep hills.

NOTE

If the  "Automatic transmission fault indicator" warning comes on, cease towing until the problem has been rectified.

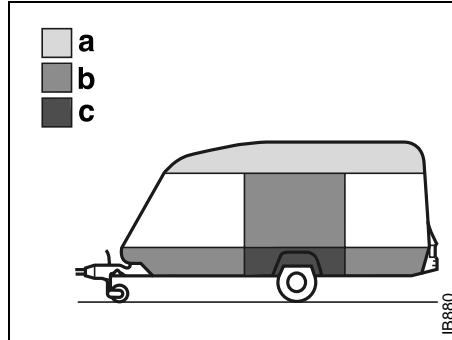

Distribution of load in trailer

- a Light
- b Moderate
- c Heavy

Driving with a roof rack load

WARNING

- A roof load will affect the car's center of gravity and aerodynamics. Be aware of this when cornering and driving in crosswinds.
- Adjust your speed to the prevailing conditions.

The maximum permissible roof load is 220 lbs (100 kg). Note that the roof load is included in the car's maximum permissible load (see page 221).

Strong, sturdy roof carriers designed specially for the car are available from your Saab dealer. Always secure the roof load safely.

Installing the roof carriers (accessory)

The carrier feet are marked with a top view of the car and an arrow indicating their positions.

- 1 Slip the plastic cover onto the adjustable foot of the carrier (the foot with a knob for tightening) to protect the paintwork during assembly.
- 2 Open all the doors.
Fold back the rubber strip and locate the fixing holes. On Coupés, the cover plates for the rearmost points of attachment must be removed.
- 3 Position the carrier gently across the roof, with the rigid foot towards you. Hold the foot clear of the roof to avoid damaging the paintwork.



Mounting holes for load carrier, front on Coupés and front/rear on five-door models

- 4 Fold back the rubber strip and insert the pins of the foot into the fixing holes. In fitting the rear carrier on Coupés, press the foot down over the pins in the mounting and slide it forward.
- 5 Carefully close the doors on this side, so as to hold the feet in place.
- 6 Move to the other side of the car and remove the plastic cover from the adjustable foot. Fold back the rubber strip and insert the pins of the foot into the fixing holes.

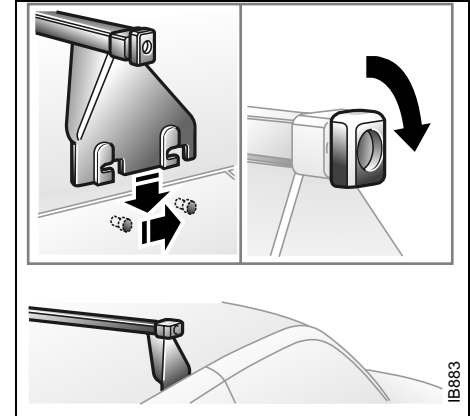

Carrier mounting, rear, on Coupés

- 7 When fitting the rear carrier on Coupés, press the foot down over the pins in the mounting and slide it forward.
- 8 Make the carrier hand-tight by turning the knob clockwise.

Driving with a load

The driving characteristics of the car are affected by the way it is loaded.

- Place heavy loads as far forward and as low as possible in the trunk.
- Secure the load to the tie downs, see page 129.
- The load should be such that the car's total weight or axle weight are not exceeded, see page 221.
- Heavy loads mean that the car's center of gravity is further back. As a result, the car will sway more during evasive steering.
- Never exceed the permissible load in the roof box, even if there is room for more.
- Ensure that the tire pressure is correct – slight overinflation is preferable to underinflation.
- The braking distance of a loaded car is always greater. Keep your distance from the vehicle in front.

Tire pressure, see page 192 and back cover.

Towing the car

WARNING

- The towing vehicle should always be heavier than the vehicle being towed.
- Never allow passengers to ride in the car being towed.
- Remember that the brake servo does not operate when the engine is off. Much greater pressure than normal will therefore be required to operate the brake pedal.
- Nor does the steering pump operate when the engine is off. The steering will therefore be much heavier than usual.
- Always seek professional help if the car needs to be towed.

The car is fitted with towing eyes at both front and rear. For access to the front towing eye, compress the grille (see illustration) and pull it straight out.

If the car is equipped with a trailer hitch, this can be used to tow another car.

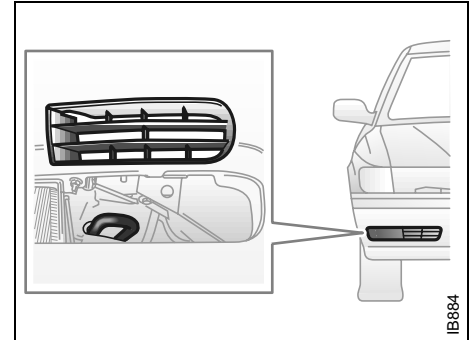

Front towing eye

Transporting the car

NOTE

If a car with sports (lowered) chassis is transported, for example on a flat bed truck, take extra care not to damage the spoiler and/or underbody.

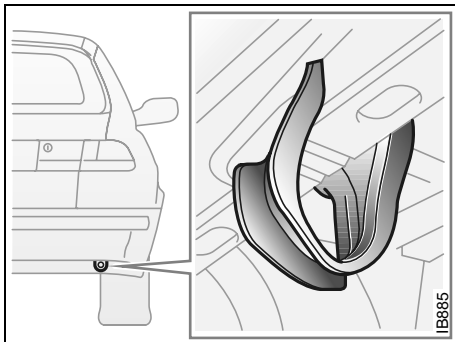

Rear towing eye

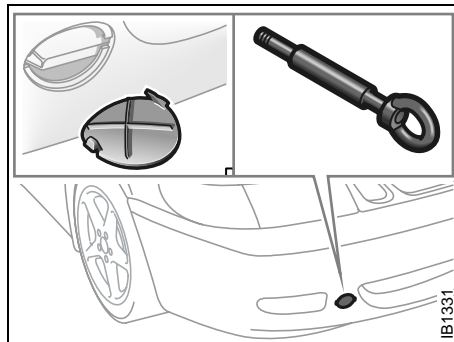

Front towing eye, Saab 9-3 Viggen

Saab 9-3 Viggen

The front towing eye is stored in a storage bag beside the spare wheel. Remove the plastic cover with a screwdriver from the car's toolkit, and screw in the towing eye.

NOTE

The design of the underside of the **rear** bumper means that the rear towing eye must not be used. This is to prevent damaging the bumper.

Towing a car with manual gearbox

The gear lever must be in neutral. Switch hazard lights on.

Drive carefully and do not exceed the speed limit for vehicles in tow.

Always try to keep the towrope taut by gently applying the brake as necessary. This will avoid the towrope being jerked violently.

NOTE

If the car is to be towed with the front wheels off the ground, make sure the parking brake is off, as this acts on the rear wheels.

Towing a car with automatic transmission

The following rules must be observed if a car with automatic transmission is to be towed.

The gear selector must be in the N position. Switch hazard lights on.

Drive carefully and do not exceed the speed limit for vehicles in tow.

Always try to keep the towrope taut by gently applying the brake as necessary. This will avoid the towrope being jerked violently.

NOTE

The car must be towed front first.

If the car is to be towed with the front wheels off the ground, make sure the parking brake is off, as this acts on the rear wheels.

- 1 Selector lever in position N.
- 2 Raise the oil level in the gearbox above normal by 2 extra quarts. Use oil of type Texaco Texamatic Dexron III.
- 3 The local regulations on towing speeds must be followed.
The highest permissible towing speed is 30 mph (50 km/h), unless the legal limit is lower. The longest permissible towing distance is 25-30 miles (40-50 km). If the car has to be transported farther than that, summon a tow truck. A flat bed tow truck is the preferred method to tow.
- 4 When the car is being returned to service, check the gearbox oil, and reduce it to the prescribed amount if necessary.

The engine cannot be started by towing or pushing the car. In emergency, the engine can be started as described in the section "Jump starting".

Jump starting

If your battery has run down, you may want to use another vehicle and some jumper cables to start your Saab. Follow the steps below to do it safely.



Batteries can cause injury. They can be dangerous because:

- They contain acid that can burn you.
- They contain gas that can explode or ignite.
- They contain enough electricity to injure you.

If you do not follow these steps exactly, some or all of these things can hurt you.

NOTE

Ignoring these steps could result in costly damage to your vehicle that would not be covered by your warranty.

Trying to start your car by pushing or pulling it could damage your vehicle, even if you have a manual transmission. If you have an automatic transmission, your vehicle cannot be started by pushing or pulling it.

To jump start your vehicle:

- 1 Check the other vehicle. It must have a 12-volt battery with a negative ground system.

NOTE

If the other system is not a 12-volt system with a negative ground, both vehicles can be damaged.

- 2 Get the vehicles close enough so the jumper cables can reach, but be sure the vehicles are not touching each other. If a poor connection on the negative jumper cable should exist, it is possible for damage to be caused to electrical systems/components of either vehicle should inadvertent contact be made. You would not be able to start your car and bad grounding could damage the electrical systems.

! WARNING

You could be injured if the vehicles roll. Set the parking brake firmly on each vehicle. Put an automatic transmission in P (Park) or a manual transmission in Neutral.

- 3 Turn off the ignition on both vehicles. Turn off all lights that are not needed, and radios. This will avoid sparks and help save both batteries and it could save your radio.

NOTE

If you leave your radio on, it could be badly damaged. The repairs would not be covered by your warranty.

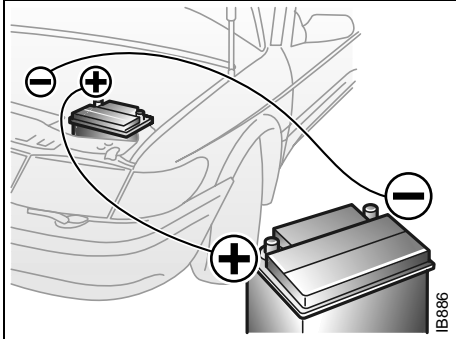

- 4 Open the hood and locate the battery. Find the positive (+) and negative (-) terminals on the battery.

! WARNING

An electric fan can start up even when the engine is not running and can injure you. Keep hands, clothing and tools away from any underhood electric fan.

 **WARNING**

Using a match or flame of any kind near a battery can cause battery gas to explode. You can suffer burns or be blinded. Use a flashlight if you need more light.

Be sure the battery has enough water. The battery installed in your new Saab has filler caps. Be sure the right amount of water is there. Add distilled or boiled water if the level is too low. If you don't, explosive gas could be present.

Be sure the electrolyte in the battery is not frozen. Discharged batteries will freeze. When connecting jumper cables to a frozen battery, gas from the chemical reaction inside the battery can build up under the ice and cause an explosion.

Battery fluid contains acid that can burn you. Do not get it on you. If you accidentally get it in your eyes or on your skin, flush the area with water and get medical help immediately.

- 5 Check that the jumper cables do not have loose or missing insulation. If they do, you could get a shock and also the vehicles could be damaged. Before you connect the cables, here are some basic things you should know. Positive (+) will go to positive (+) and negative (-) will go to negative (-) or a major metal engine part with a good ground. Do not connect (+) to (-) or you will get a short that could injure you or would damage the battery and maybe other parts as well.
- 6 Connect the red positive (+) cable to the positive (+) terminal of the vehicle with the discharged battery.
- 7 Do not let the other end touch metal. Connect it to the positive (+) terminal of the good battery. Use a remote positive (+) terminal if the vehicle has one.
- 8 Now connect the black negative (-) cable to the good battery's negative terminal. Do not let the other end touch anything until the next step. The other end of the negative cable **does not** go to the dead battery. It goes to a major metal part with a good ground on the engine of the vehicle with the discharged battery.
- 9 Attach the cable at least 18 inches (45 cm) away from the discharged battery, but not near engine parts that move. The electrical connection is just as good there, but the chance of sparks getting back to the battery is much less.
- 10 Start the vehicle with the good battery and run the engine for a while.
- 11 Try to start the vehicle with the discharged battery. If it does not start after a few tries, it probably needs service.
- 12 Remove the cables in reverse order to prevent electrical shorting. Take care that they do not touch each other or any other metal.

Driving considerations with compact spare wheel/tire fitted

WARNING

Do not exceed 50 mph (80 km/h) as the tire can overheat and adversely affect the handling of the car.

The tire should be inflated to 60 psi (420 kPa).

The following should be observed when the compact spare wheel (T115/70 R16) is installed:

The compact spare is light and easy to handle when changing the wheel. Do not drive farther than necessary with the compact spare fitted – the maximum life of the wheel is only just over 2000 miles (3,500 km). Have the standard wheel repaired and reinstalled as soon as possible.

The car's ground clearance is reduced with the compact spare fitted. Note that only one compact spare wheel may be used at any time. Take care not to hit the curb and do not fit snow chains. Leave the wheel cover off, so that the warning text is readily visible.

NOTE

To avoid damaging a punctured alloy wheel this can be placed outside up in the spare-wheel well but **only** while driving to the closest workshop.

A general rule is that all heavy loads must be well secured in the luggage compartment, see page 129.

For long trips

Before starting off on a long journey, it is advisable to have your car inspected over by your Saab dealer.

Obtain a few important items to take along on your journey such as spare bulbs, wiper blades, fuses, a Poly-Vee-belt and the like. You can check some points yourself beforehand:

- Make sure that the engine is in good condition.
- Check that no oil or fuel leaks out of the engine or gearbox/transmission.
- Inspect the Poly-Vee-belt and replace it if it shows any signs of wear.
- Check the battery charge.
- Check the tires for tread pattern and air pressure, including the compact spare wheel.
- Take an extra car key/remote control and keep it separate, see also page 30.
- Check the brakes.
- Check all bulbs.
- Check for the presence of the tool kit and the jack in the car.

Driving with the trunk lid open

Avoid driving with the trunk lid partly or fully open, since exhaust fumes can be drawn into the cabin.

If you must drive with the trunk lid open, all windows and the sunroof (if fitted) must be closed and the cabin fan on at its highest speed setting.

Driving in deep water

NOTE

Do not drive in water deeper than 11" (30 cm) and do not drive faster than at idling speed. Water can otherwise be sucked into the engine. The engine will be damaged if water enters the intake system.



IB944

Car care

Hood release handle	168	Upholstery and trim	200
Engine	168	Textile carpeting	200
Engine bay	169	Engine bay	201
Engine oil	172	Washing	201
Transmission fluid	173	Waxing and polishing	202
Coolant	174	Touching up the paint	202
Brake- clutch fluid and brake pads	176	Anti-corrosion treatment.	203
Power steering	177	Recovery and/or recycling of automotive materials.	205
Battery	177	Air conditioning (A/C system)	207
Drive belt	179		
Wipers and washers	179		
Wiper blades	179		
Changing bulbs	181		
Fuses	187		
Wheels	192		
Safety belts	199		

Hood release handle

The handle of the hood lock is located on the left under the instrument panel. Open the hood in the following way:

- 1 Pull the release handle.
- 2 The hood moves to the half-locked position and is stopped by a safety catch at the front edge.
- 3 Press the lever of the catch upwards and raise the hood.

When you close the hood you should drop it from a height of about 8 inches (20 cm), **without** slamming it.

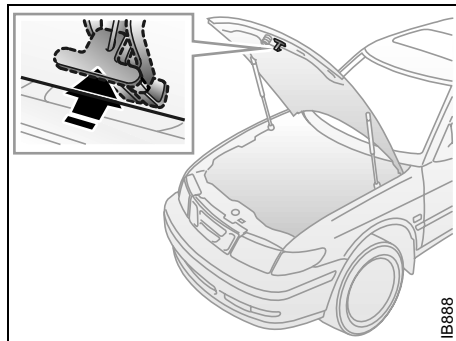

Hood release pressure plate

Engine

The engine is a transverse four-cylinder in-line engine with twin overhead camshafts and 16 valves.

The engine is equipped with two balance shafts that reduce engine vibration to a minimum.

The balance shafts are chain-driven and rotate at twice the speed of the crankshaft. They produce forces and torques that are opposed to those generated by the pistons and connecting rods. The effect occurs twice in each revolution of the engine, counteracting the vibration from its moving parts, and at the same time reducing unwanted engine noise.

The gearbox, located on the right (viewed from the front), is integrated with the engine.

Hood release handle

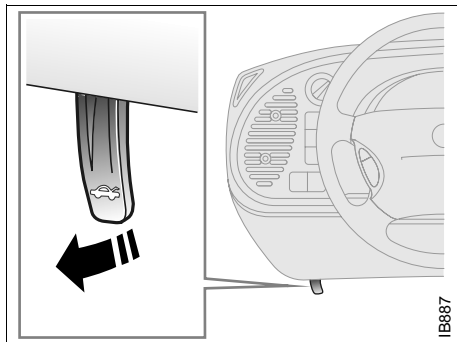

Engine bay

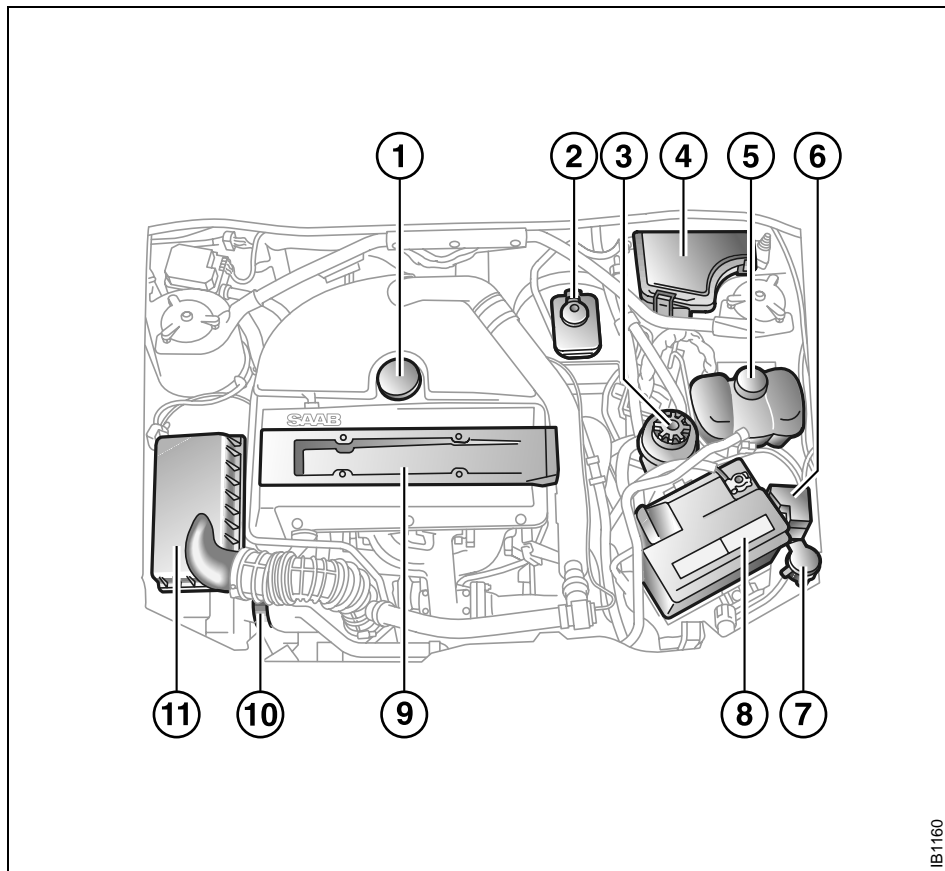

- 1 Engine-oil dipstick
- 2 Brake-fluid reservoir
- 3 Power-steering fluid reservoir
- 4 Fuse box
- 5 Coolant reservoir
- 6 MAXI fuses
- 7 Washer-fluid reservoir
- 8 Battery
- 9 Ignition discharge module
- 10 Drive belt
- 11 Air filter

Engine families

Saab cars imported into the United States and Canada meet all applicable emission control standards. The engine family and appropriate tune-up specifications are identified on a label affixed to the left front inner fender.

These engine families meet applicable EPA Federal Standards, California State Standards and Canadian Federal Standards and are equipped with the following systems:

- Sequential multiport fuel injection system.
- Three way catalytic converter.
- Crankcase emissions control system.
- Evaporative emission system.

Emission control systems

The systems for controlling emissions to the atmosphere require regular checking and adjustment at the intervals specified in the service program.

In addition to meeting the exhaust emission regulations and thereby helping to keep the environment clean, a correctly tuned engine will also give maximum fuel economy.

Saab Trionic engine management system

The Saab Trionic engine management system is a unique Saab development that combines sequential multiport fuel injection, electronic distributorless ignition and turbo-charger boost pressure control into one system.

The Trionic engine control module (ECM) monitors many different engine parameters such as:

- Intake manifold pressure.
- Intake air temperature.
- Crankshaft position.
- Engine coolant temperature.
- Throttle position.
- The oxygen content of the exhaust gases.

The ECM receives information regarding engine knocking from a sophisticated feedback function in the ignition discharge unit. By processing all of this information, the Trionic system can control fuel injector opening duration, ignition timing and turbo-charger boost pressure to provide excellent engine performance while maintaining low emissions and fuel consumption.

NOTE

The Trionic engine management system continuously monitors the operation of these systems and has on-board diagnostic capabilities (OBD II). If the CHECK ENGINE light in the main instrument illuminates, the Trionic ECM has detected a problem. The car will continue to operate, but performance may be diminished. You should have your car checked by a Saab dealer as soon as possible.

ORVR (Onboard Refueling Vapor Recovery)

All hydrocarbons formed when refuelling will be recovered by the car and not released into the atmosphere. The hydrocarbons are absorbed in an evaporative emission canister. When the engine is subsequently started, the evaporative emission canister is gradually purged as air is sucked into it through a shut-off valve. The hydrocarbon/air mixture passes through the evap canister purge valve and into the engine where it is burned. "Refueling", see page 138.

Engine oil

Checking the fluid level

Regularly check the oil level in the engine. Do this with the car standing on level ground with the engine warm, 2-5 minutes after it has been turned off. Take the dipstick out and wipe it off with a clean rag before carrying out the check.

The level must not be below the MIN mark on the dipstick, but nor should it be above the MAX mark. Excess engine oil could result in abnormal oil consumption.

The distance between MIN and MAX corresponds to a volume of about one quart.

When necessary, add oil of the recommended grade via the dipstick pipe. Make sure that the cap of the dipstick is screwed on properly after the check.

Oil changing

The engine oil must be changed in accordance with the service program, see page 215.

Oil volume and grade, see page 223.

Oil changing should be carried out on a warm engine.

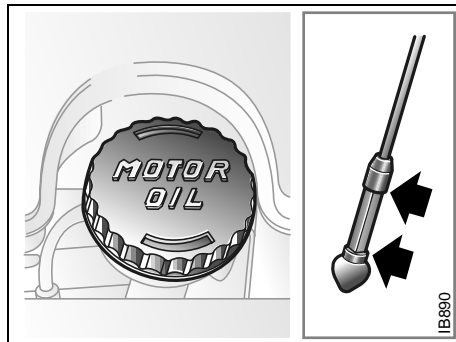

Oil filler cap and dipstick

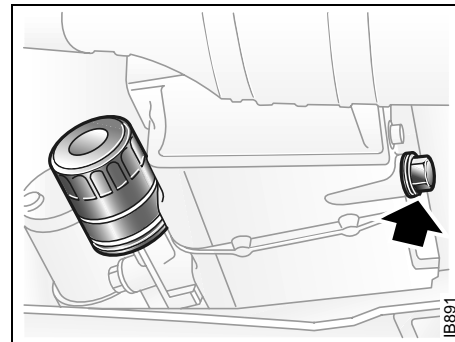

Drain plug

- 1 Unscrew the drain plug in the bottom of the sump and leave the oil to drain into an oil tray or other suitable receptacle for at least ten minutes. Take care, as the oil may be hot.
- 2 After the oil has been drained, unscrew and remove the oil filter.
- 3 Fit a new filter and tighten it by hand.
- 4 Refit the drain plug with a new washer.
- 5 Add new oil.

Run the engine to normal temperature and check the oil level.

NOTE

Change of engine oil and oil filter may be required more frequently (5000-mile intervals (8,000 km)) if any one of the following conditions apply to the car:

- Most trips are less than 5 to 10 miles (8 to 16 km). This is particularly important when outside temperatures are below freezing.
- Most trips include extensive idling (such as frequent stop-and-go driving).
- Most trips are through dusty areas.
- You frequently tow a trailer or use a carrier on top of your vehicle.
- You frequently tow a trailer or use a carrier on top of your vehicle.
- If the vehicle is used for delivery service, police, taxi or other commercial applications.

 **WARNING**

- Prolonged and repeated exposure of the skin to engine oil can cause serious skin disorders.
- Avoid prolonged skin contact whenever possible. Wash the affected area thoroughly with soap and water after any contact.
- Keep oil out of reach of children.
- Do not touch the turbocharger or manifold. These get very hot when the engine has been running.
- Do not spill oil on hot parts of the engine as this could cause a fire.
- Protect the environment. Do not dispose of oil in the ground or down a drain. Dispose of all used oil and oil filters at an appropriate disposal facility.

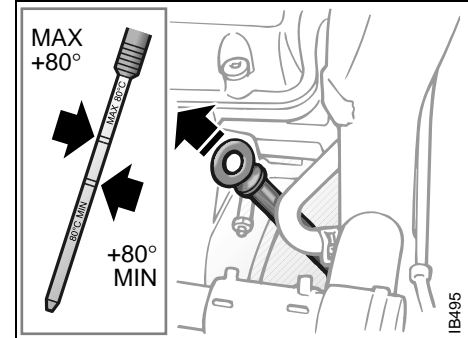

Oil dipstick, automatic transmission

Transmission fluid

Manual transmission

Check and top up the fluid in accordance with the service program.

If original fluid cannot be obtained for topping up, Dexron III (synthetic fluid) automatic transmission fluid can be used. If so, the car should be taken to an authorized Saab dealer as soon as possible to have the reason for low fluid level corrected and original fluid installed.

Automatic transmission

Check the fluid level as follows:

- 1 Park the car on level ground and apply the parking brake. The automatic transmission fluid must be at normal running temperature, approximately 175°F

(80°C). This can be achieved by driving the car for about 30 min on the open road.

- 2 With the engine idling, move the selector lever to D and wait for at least 15 seconds. Next, move the selector lever to R and wait for 15 seconds again. Finally, move the selector lever to P. Let the engine idle.
- 3 Wipe the dipstick clean with a lint-free cloth and put it back.
- 4 With the fluid at normal temperature, the level should be between the MAX and MIN marks on the dipstick. Top up, as necessary, with Texaco Texamatic Dexron III automatic-transmission fluid, adding it through the dipstick pipe. The distance between the MIN and MAX marks on the dipstick corresponds to a volume of approximately 0.4 qts (0.4 litre).

NOTE

If there is a burnt smell or the fluid is black, change the fluid as soon as possible.

If the outside temperature is below 50°F (10°C), the fluid will not reach the specified temperature of 175°F (80°C). In this case, the correct fluid level may be 0.8 in (20 mm) below the MAX mark.

Coolant

The expansion tank is transparent, to facilitate checking. The level must be a little under the mark "KALT – COLD" on the tank when the engine is cold. If the SID message "FILL COOLANT FLUID" is displayed, the level in the expansion tank should be checked. Top up as necessary with equal parts of clean water and coolant. Use only coolant approved by Saab.

If the expansion tank is empty when coolant is added, run the engine to normal temperature and top up again, as necessary.

Coolant

The cooling system is filled at the factory with coolant containing a 50% concentration of a combined antifreeze and corrosion inhibitor. A weaker mixture will result in reduced anticorrosion protection. For protection against freezing in very cold weather, a stronger concentration will be needed.

A 60% concentration of antifreeze will provide protection at temperatures down to -58 F (-50°C).

The corrosion-inhibiting properties of the coolant deteriorate over time, but coolant approved by Saab can be used for year-round protection. Change the coolant as specified in the service program (page 215) and use only coolant approved by Saab – other makes may need changing more frequently and may damage the system.



Coolant expansion tank

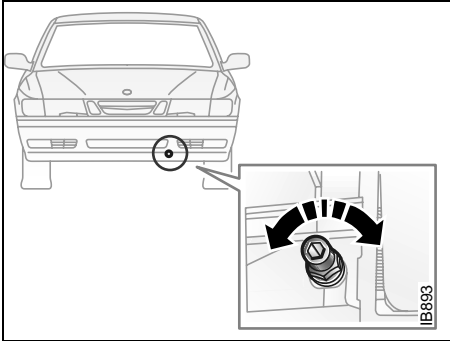

Radiator drain cock

NOTE

Always mix the antifreeze with the appropriate volume of water before adding it to the cooling system.

If pure antifreeze is added, the engine could still freeze and be damaged. This is because the antifreeze will not mix properly with the coolant before the thermostat has opened to allow full circulation.

! WARNING

- Proceed with caution if the radiator is boiling when you open the hood. Never remove the expansion-tank filler cap when the radiator is boiling. Loosen the cap carefully, and let the engine cool before removing the cap.
- The cooling system is pressurized – hot coolant and vapor can escape when the filler cap is released.

Changing the coolant

(Usually carried out as part of the Saab original service by an authorized Saab dealer)

- 1 If the engine is hot, loosen the expansion-tank filler cap a little to release the pressure. Leave the cap in place.
- 2 Fit a suitable piece of hose onto the nipple of the drain cock. Let the hose discharge into a receptacle under the radiator and open the drain cock, which is located on the inside of the radiator facing the engine bay.
- 3 Remove the filler cap on the expansion tank.
- 4 In a couple of minutes the system will be empty. Close the drain cock.
- 5 Mix antifreeze and water in a suitable container. Use only Saab-approved coolant.
- 6 Add the coolant slowly to the expansion tank. This will take about two minutes, as the air needs time to escape.
- 7 Screw the expansion-tank cap on and run the engine to normal temperature. Top up with coolant until the level is just under the "KALT – COLD" mark on the tank.
- 8 Check the coolant again after a few days and top up as necessary.

Brake- clutch fluid and brake pads

WARNING

Brake fluid deteriorates as it becomes old. Because it is hygroscopic, it absorbs water from the air and, in time, could allow vapor to form in the brake system, thus reducing its performance. It is therefore important that brake fluid be changed regularly, as specified in the service program, see page 215.

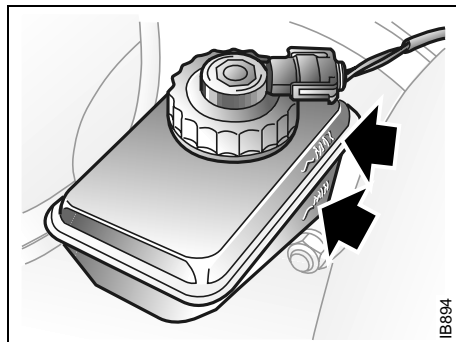

Checking the fluid level

The combined brake and clutch-fluid reservoir is transparent to facilitate checking of the fluid level.

The level should be between the MAX and MIN marks. Top up, as necessary, with **DOT 4** fluid. Do *not* use DOT 5 brake fluid. Use only new brake fluid from a sealed container.

Check that there are no leaks in the brake system.

Changing of the brake fluid should be carried out by an authorized Saab dealer.

The vehicle's regular braking system is adjusted automatically, but the parking brake has to be adjusted manually. This work, involving adjustment of the parking brake cables and brake pads, must only be carried out by an authorized Saab dealer.

It is not possible to detect, through abnormal pedal or parking brake-lever travel, whether

brake pads are worn and need replacing. It is therefore essential that brake pads be checked regularly, as specified in the service program, see page 215.

NOTE

Avoid spilling brake fluid onto paintwork, since it can cause the paint to bubble and lift. If any brake fluid is spilled, the area should be flushed with large quantities of water as quickly as possible.

Brake pad wear indicators

The outboard brake pads on the front wheels incorporate pad-wear indicators. When the lining is down to 0.11 in (3 mm), the pad will produce a screeching, squealing or scraping noise when the brakes are applied. New pads should be installed without delay.

Brake pads should only be changed by an authorized Saab dealer. To ensure optimum brake performance, use only Saab original brake pads.

Power steering

Check the level of the power-steering fluid in the reservoir regularly, in accordance with the service program.

The wheels should point forward during the check.

Clean around the cap before it is unscrewed.

Unscrew the cap and wipe the dipstick. To check the fluid level, first screw the cap on fully again and then remove. The level should be between the MAX and MIN marks on the dipstick when the oil temperature is about 68°F (+20°C). If the oil is colder the oil level can be lower, and in higher temperatures the level can be higher, both of which are acceptable.

Top up with power-steering fluid CHF 11S (part number 3032380).



Power-steering fluid reservoir

Battery

WARNING

- Work on the battery may entail an explosion hazard, since the battery gives off hydrogen which forms an explosive mixture with the oxygen in the air. For this reason, always avoid sparks or open flames when working near the battery.
- The battery contains corrosive sulphuric acid. Always wear a face mask or goggles when working on the battery.
- If battery acid gets into the eyes or splashes the skin or clothing, wash the affected area liberally with water. If acid gets into the eyes or a large quantity makes contact with the skin, seek medical help.

The liquid level in the car battery must be checked at regular intervals.

NOTE

Never use tap water to top up the battery.

Tap water contains salts and minerals that accelerate the corrosion of the battery electrodes, which can shorten the life of the battery.

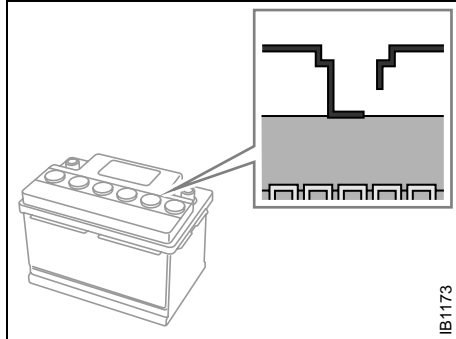

IB1173

Correct fluid level in the battery

The charge level should be checked with a battery-acid tester. The specific gravity of the acid in a fully charged battery should be 1.28. A specific gravity of 1.18 roughly indicates a 50% charge.

NOTE

A discharged battery can freeze and fracture. Batteries should therefore always be stored away from frost.

If frequent short journeys are made in cold weather, the battery may need to be given a booster charge. This can be done either using a battery charger or by taking the car for a long drive.

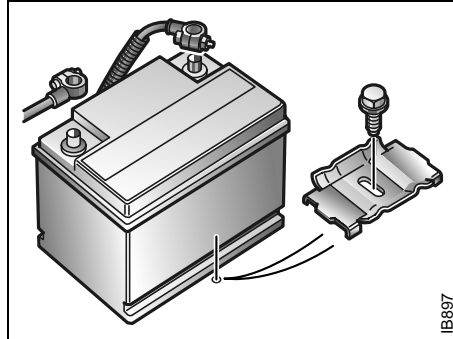

IB897

Taking out the battery

A car with standard equipment and a fully charged battery can be left for up to 40 days and still have a sufficient charge for starting. If extra equipment is fitted, such as a mobile telephone, the time may be reduced to about 15 days.

Always connect the positive (red) cable to the positive (+) terminal of the battery and the negative (blue) cable to its negative (-) terminal. Always disconnect both battery leads when boost charging the battery.

NOTE

- Don't connect the battery terminals + and - the wrong way around.
- Serious damage can occur to the car's electrical system if a battery or alternator lead is disconnected while the engine is running.

Drive belt

WARNING

- Keep hands and clothing clear of drive belts when engine is running.
- Always stop the engine before inspecting drive belts.

NOTE

Serious damage can occur to the car's electrical system if an alternator lead is disconnected while the engine is running.

The alternator is situated on the right-hand side of the engine. It is driven via a poly-V-belt from the crankshaft pulley.

The poly-V-belt also drives the water pump, the A/C compressor and the steering servo pump.

The belt tension is critical, and is adjusted by an automatic belt tensioner.

See also page 55, "Warning charging".

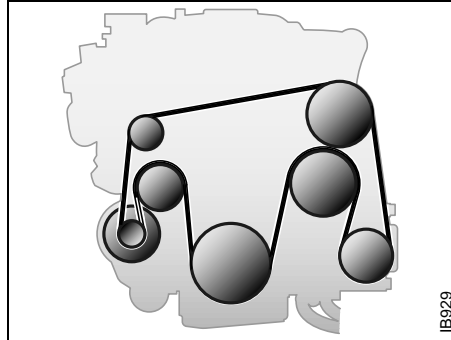

Drive belt

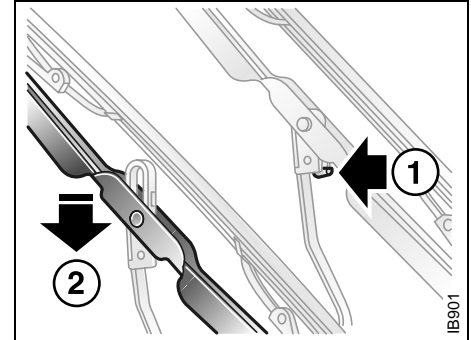

Windshield and rear window

- 1 Push the catch in (1).
- 2 Pull the complete wiper blade downwards so that it comes away from the wiper arm. Slide the entire blade out from the arm.

Wipers and washers

Wiper blades

Check and clean all wiper blades regularly. We recommend Saab washer fluid for cleaning.

If poor wiper performance is experienced, clean the windshield with Saab washer fluid. This is particularly important if the car has been through an automatic car wash, as this sometimes leave a wax coating on the windshield.

If wiper performance is still unsatisfactory, fit new blades.

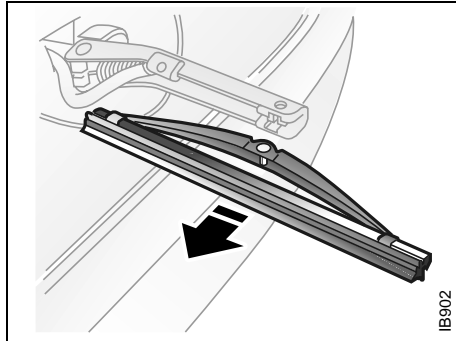

IB902

Headlight wipers

- 1 Lift the wiper arm off the headlight.
- 2 Detach the wiper blade by pulling it laterally from the wiper arm.
- 3 Fit the new blade by sliding it into the retainer on the wiper arm and pressing it firmly home.

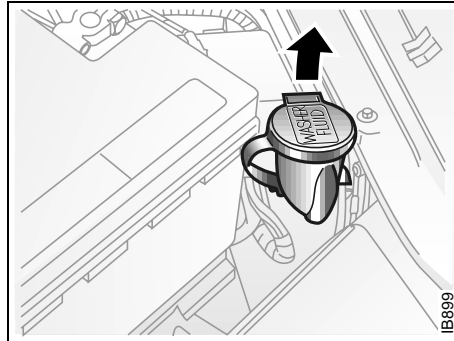

IB899

Washer-fluid reservoir

Washer

The reservoir holds 5 quarts (4.7 litres). When the SID message "WASHER FLUID LEVEL LOW" appears there is about 1.5 quarter (1.4 litres) left.

Fill with quality washer fluid, available from your Saab dealer and follow the instructions on the package to reduce the risk of freezing.

If the reservoir is run dry and the car has a rear-window wiper, then after refilling you cannot wash the rear window until you have first washed the windscreen.

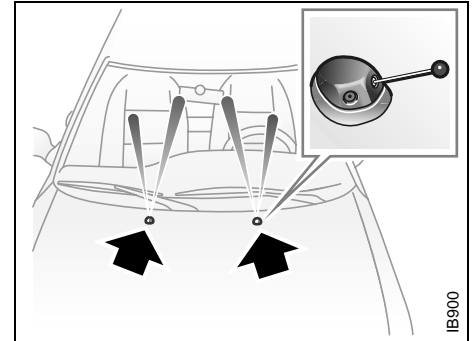

IB900

Washer jets

The washer jets, which are adjustable, can be cleaned with a pin if necessary.

The jet for rear-window washing is located in the right-hand part of the high-mounted brake light.

Changing bulbs

WARNING

Before changing a bulb in the engine bay, switch off the engine to avoid the danger of fingers and hands being injured by moving parts.

The radiator fan can cut in even when the engine is switched off.

NOTE

Switch off the ignition before changing a bulb, to avoid possible short-circuiting.

Headlight

- 1 Unscrew the cover from the back of the light units.
- 2 Unplug the connector.
- 3 Unhook the spring clip by pushing it forward and then to the side.
- 4 Remove the bulb.
- 5 Insert the new bulb, without touching the glass with your fingers. Line it up so that the three lugs fit into the corresponding slots in the reflector and secure it with the spring clip.

NOTE

Do not fit bulbs with a rating above 60/55W, since the headlight reflector and the wiring of the car are not designed for a higher wattage.

Do not touch the glass of the bulbs with your fingers. The oil on your skin can shorten the life of the bulb.

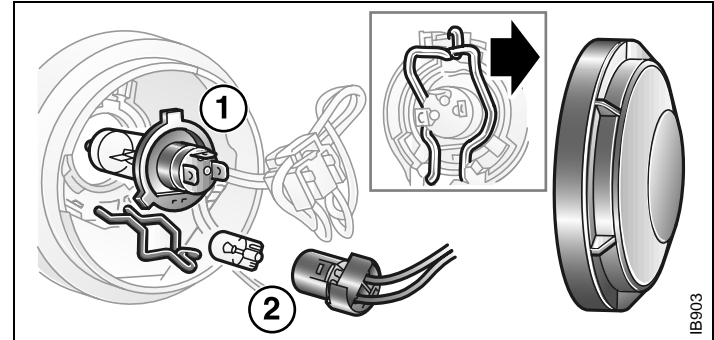

- 1 Headlight bulb
- 2 Parking-light bulb

IMPORTANT! When changing bulbs, use the same type of bulb, (e.g. Long-life).

Headlight aiming, see page 208.

Parking lights

The parking-light bulb is fitted in the same light unit as the headlight bulb.

- 1 Remove the bulb holder from the lamp unit.
- 2 Then take the bulb out of the holder.

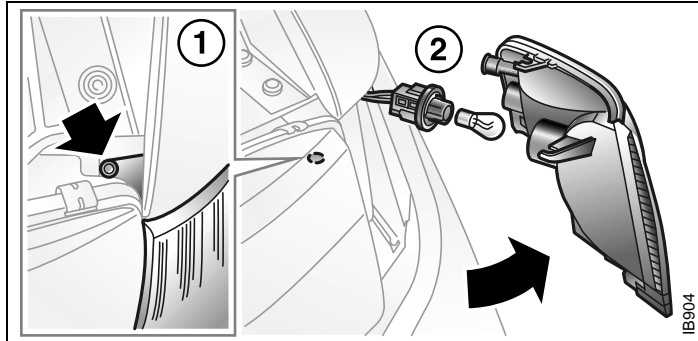

- 1 Retaining screw
- 2 Turn signal bulb

Front turn signal bulb

To change the bulb, the complete lamp unit has to be removed.

- 1 Loosen the screw (1). There is no need to remove it completely.
- 2 Carefully remove the complete lamp unit.
- 3 Grasp the two plastic tabs and turn the bulb holder counterclockwise.
- 4 Pull the bulb holder out of the lamp unit and change the bulb.
- 5 Check that the new bulb is firmly in place and has good contact.
- 6 When mounting the lamp unit, see that the two guide lugs on the rear edge of the unit come inside the edge of the body panel.
- 7 Insert the lamp unit in towards the headlight and see that the front bracket comes under the screw. Tighten the screw (1).

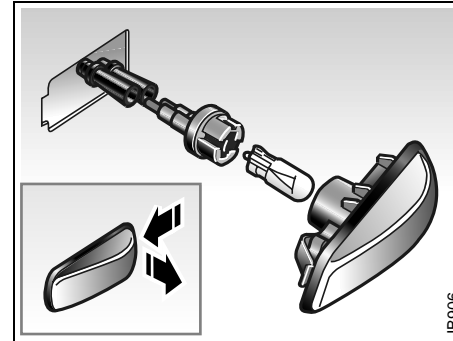

Side-mounted turn signal

- 1 Slide the lens forward so that its rear part can be pulled out.
- 2 Change the bulb.
- 3 When refitting, make sure that the groove in the spring engages the edge of the body panel and that the rubber gasket is correctly positioned.

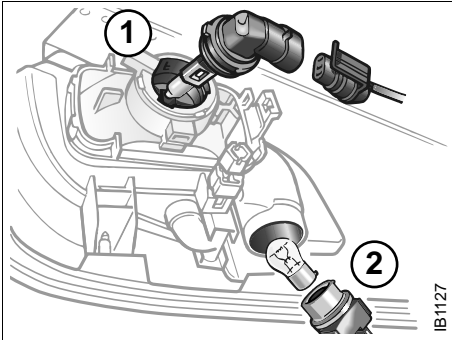

Front fog lights and cornering lights

- 1 Front fog light
- 2 Cornering light

Front fog light / cornering lights

- 1 Slightly turn the bulb holder counter-clockwise.
- 2 Unplug the connector.
- 3 Remove the bulb.

⚠ WARNING

Never crawl under a car that is supported only by a jack use axle stands; for further information about jacking up the car, see page 197.

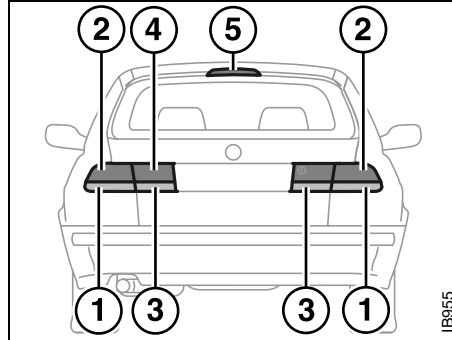

Rear light clusters

- 1 Direction indicators
- 2 Tail lights/stop lights
- 3 Reversing lights
- 4 Rear fog light
- 5 High-mounted stop light

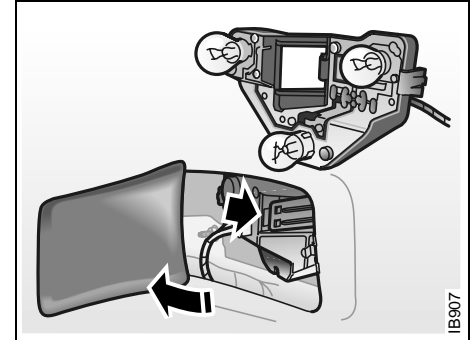

Stop lights, taillights and direction indicators

- 1 Open the door in the trunk upholstery.
- 2 Press aside the plastic tab that secures the bulb holder.
- 3 Carefully pull the entire bulb holder out of the lamp unit. Replace the dead bulb.
- 4 When the bulb holder is being refitted, check that its plastic catches snap into place.

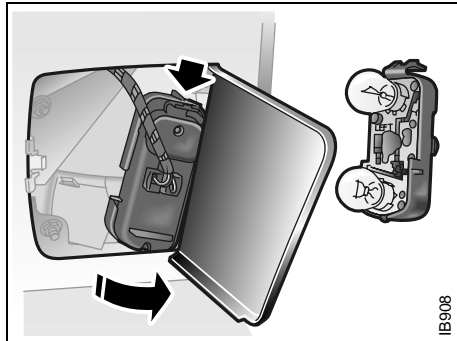

Reversing lights and rear fog light

- 1 Open the hatch on the inside of the trunk.
- 2 Press down the plastic tab that secures the bulb holder.
- 3 Carefully pull the entire bulb holder out of the lamp unit. Replace the dead bulb.
- 4 When refitting the bulb holder, fit it in first at the lower edge. Then push the bulb holder in so that the plastic tab snaps into place.

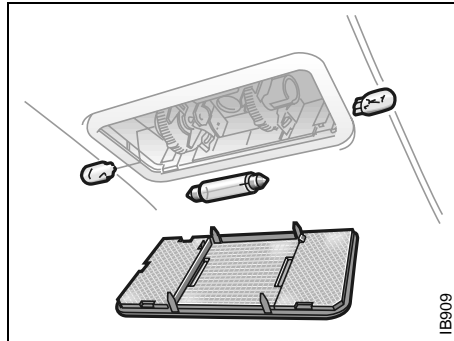

Dome light, front

- 1 Insert a screwdriver on one side and pry gently upwards. Remove the cover lens.
- 2 Change the bulb.

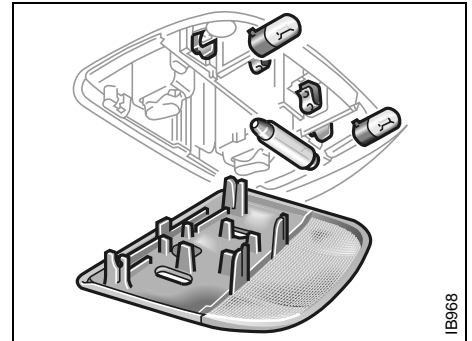

Dome light, rear

- 1 Remove the entire overhead panel: ease out the trailing end of the dome light first, and then both front edges.
- 2 Change the bulb.

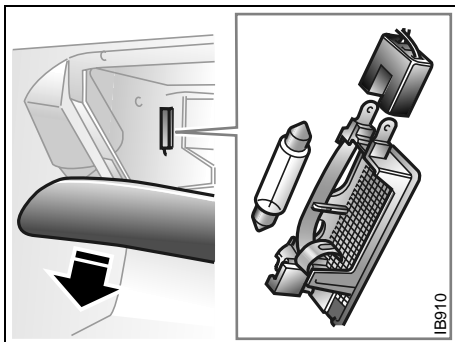

Glove-compartment lighting (detach the whole lamp unit with a short screwdriver applied at the lower edge)

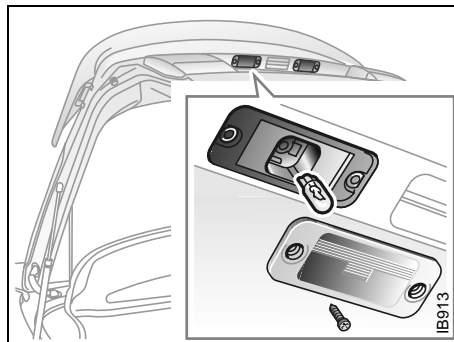

License plate lighting (the glass is held in place by two screws)

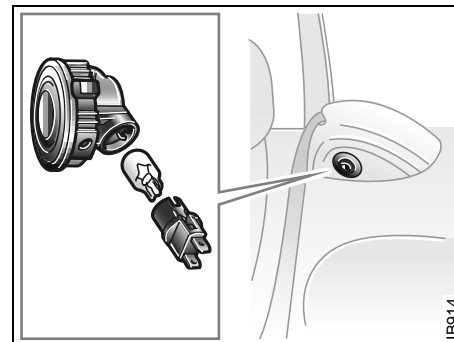

Reading lamps, rear seat (Convertible)

Trunk light (detach the whole lamp unit with a screwdriver applied at one edge)

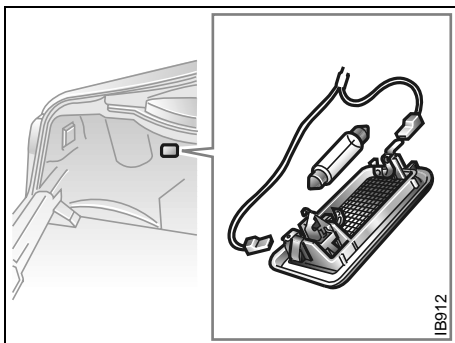

Reading lamps, 9-3 Convertible

Detach the whole lamp unit by inserting a screwdriver into the notch and carefully prying the lamp unit out. Pull the bulb holder out of its bracket and change the bulb. Replace the bulb holder in its bracket and refit the entire lamp unit.

Other lighting

If any other bulbs need changing, you are advised to take the car to an authorized Saab dealer.

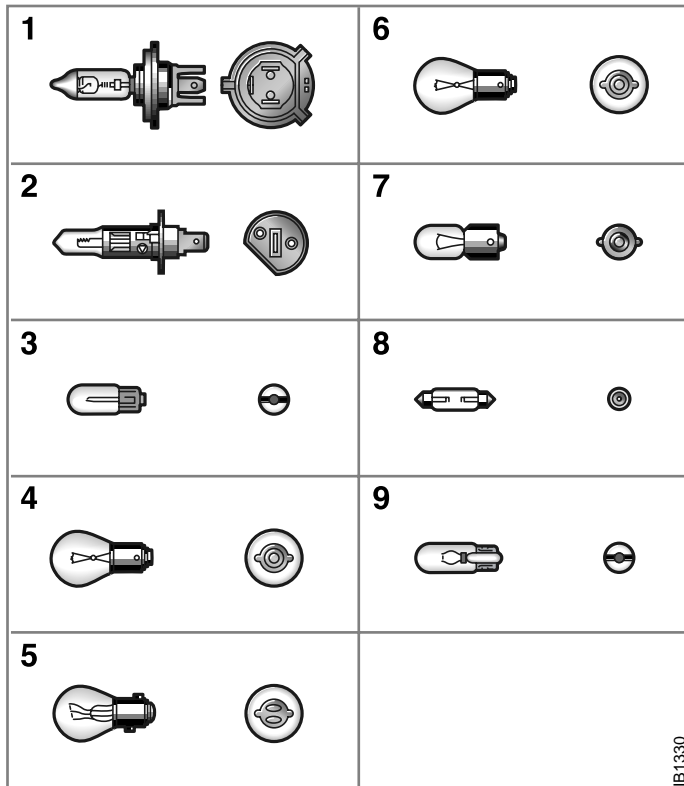

Bulb table

No.	Wattage	Cap	
1	60/55	P 43t-38	Headlight
2	55	P 14.5s	Front fog light
3	1,2	W 2 x 4.6d	Ashtray; cigarette lighter; warning light for safety belts
4	21	BA 15s	Rear fog light; reversing light
5	21/5	BAY 15d	Stop/taillight
6	PY21 yel	BAU 15s	Direction indicator, front/rear
7	5	BA9	Reading lamps, rear (Coupé and 5-door)
8	10	SV 8.5	Dome light; trunk; glove compartment
9	5	W 2.1 x 9.5d	Side indicators; license plate lighting; parking lights; reading lamps, front; reading lamps, rear (Convertible)

NOTE

Do not change any bulbs with ones of another wattage: only use what is stated.

Fuses

The fuses are housed in two fuse panels: one at the end of the instrument panel on the driver's side, and one under the hood.

To check if a fuse has blown, first remove it from the panel (see below). If the filament is broken, the fuse has blown.

A special tool for removing fuses is provided at the bottom of the fuse panel on the fascia. Simply push the tool onto the fuse, squeeze and remove the fuse.

WARNING

To avoid the risk of short-circuiting and/or fire breaking out in the electrical system, the following advice should be heeded:

- Always consult an authorized Saab dealer before modifying or adding any electrical equipment. Failure to do so can result in the electrical system being damaged.
- Never replace a fuse with one having a higher/lower rating than specified (see page 189). The color of the fuse indicates its amperage.
- If the same fuse blows repeatedly, have the electrical system checked by an authorized Saab dealer.
- If a MAXI fuse blows, it means that there is a major fault in the electrical system. Have the car checked without delay by an authorized Saab dealer.
- When a fuse is to be replaced, it is essential that the new one should have the same rating as the one being replaced (see the Table on page 189). The color of the fuse indicates its amperage.

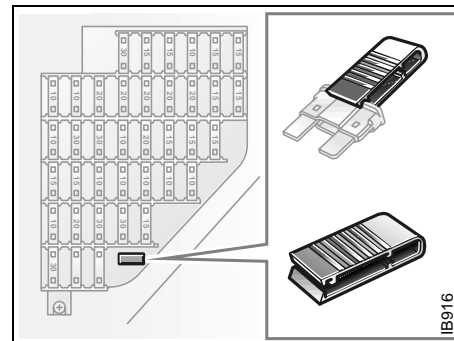

Tool for changing fuses

Sound fuse/Blown fuse

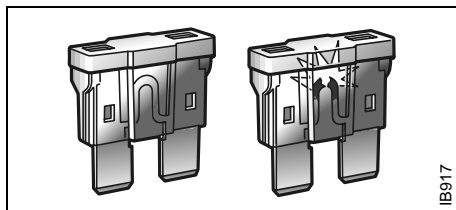

IB917

IB916

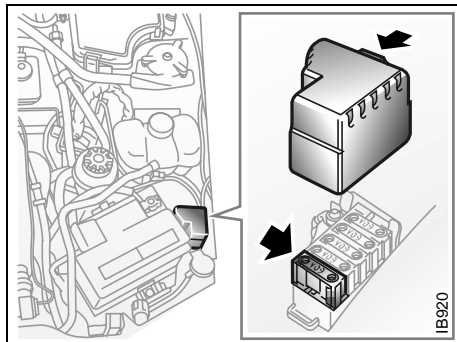

*MAXI fuse for soft-top system
(Convertible)*

MAXI fuses

The MAXI fuses are housed in the fuse box under the hood. These fuses can be checked in the same way as the other fuses. The MAXI fuses are designed to protect the car's electrical system from being damaged. Each MAXI fuse protects a number of electrical circuits and functions and therefore has a higher rating (amperage) than the standard fuses. No spare MAXI fuses are supplied with the car.

NOTE

If a MAXI fuse blows, it means that there is a major fault in the electrical system. Have the car checked without delay by an authorized Saab dealer.

DICE / TWICE

DICE = Dashboard Integrated Central Electronics

TWICE = Theft-Warning Central Electronics

DICE and TWICE are electronic control modules.

DICE controls, among other things:

- Front lights and interior lighting.
- Instrument illumination.
- Intermittent wiper operation.
- Electric heating of rear window and door mirrors.

TWICE controls, among other things:

- Central locking.
- Car alarm (Anti-theft system).
- Engine immobilizer.
- Auto checking of lights.
- Electric heating of rear seat.
- Safety belt reminder.
- Electrically adjustable passenger seat.

The DICE and TWICE control modules are linked to a data bus, which is basically an information carrier that allows information to be exchanged between all the control modules and components connected to the bus. If a fault occurs in any of these components, diagnostic faults codes are set in the relevant control module, which enhances fault diagnosis at the Saab dealer.

The scan tool connector for fault diagnosis is located under the instrument panel on the drivers side.

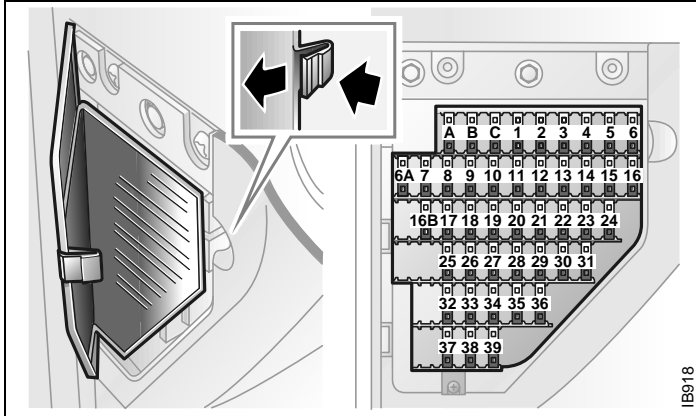

Fuse holder on the end of the instrument panel

Fuses

No.	Amp	Function
A	–	–
B	10	Stop lights, trailer
C	30	Cabin fan, ACC
1	30	Electrically heated rear window and rear-view mirrors
2	20	Direction indicators
3	30	Cabin fan, A/C
4	15	Trunk light; switch illumination; electrically powered radio antenna
5	30	Electrically operated front seat, right

6	30	Cigarette lighter
6A	7.5	Automatic transmission
7	30	Rear window operators, rear-view mirrors, sunroof
8	15	Rear wiper
9	7.5	ACC panel
10	–	–
11	7.5	DICE / TWICE
12	20	Stop lights; front fog lights
13	15	Diagnostics; radio
14	30	Front window motors
15	20	Daytime running lights
16	30	Electrically operated front seat, left
16B	30	Control module, engine management system
17	15	DICE/TWICE; instruments; memory for electrically operated driver's seat
18	10	Airbag
19	10	ABS; A/C; rear fog light
20	20	Electric heating, front seats

No.	Amp	Function
21	10	Manual A/C; soft top (Convertible)
22	15	Cruise Control; direction indicators
23	20	Soft top (Convertible); telephone
24	7.5	Radio
25	30	Central locking
26	30	Control module, engine management system; ignition cassette
27	15	High beam flash; ACC
28	10	Engine management system
29	10	Right parking light; number-plate lighting
30	10	Left parking light
31	20	Reversing light; windshield wipers; headlight beam-length adjustment
32	15	Fuel pump
33	15	Electric heating of rear seat
34	10	SID; control module; automatic transmission
35	15	DICE/TWICE; main instrument panel; interior lighting
36	10	Relay, starter
37	–	–
38	25	Oxygen sensor (lambda probe)
39	–	–

Relay holder

Under the instrument panel next to the steering wheel

Item	Function
A	Electric heating of rear seat
B	Reversing light, cars with automatic transmission
C1	–
C2	Lock motor, trunk lid
D1	Rear wiper
D2	Rear-window washing
E	Ignition switch
F	–
G	Windshield wipers (intermittent)
H	Rear-window heating
I	Fuel pump
J	–
K	Start relay
L	Main relay (injection system)

Fuses and relays

Fuse panel in engine bay

No.	Amp	Function
1	10	Horn
2	15	Front fog lights
3	40	Radiator fan, low speed
4	10	Vacuum pump
5	15	A/C-compressor
6	10	Left low beam
7	10	Right low beam
8	10	Left high beam
9	10	Right high beam
10	7.5	Headlight wipers
11	-	-
12	-	Extra lights
13	7.5	APC
14	10	Extra heater; water pump (Europe)
15	15	Extra heater (Europe)
MAXI 1	30	Radiator fan, high speed
MAXI 2	50	ABS

Item	Amp	Function
A		Low beam
B		High beam
C1		Extra heater (Europe)
C2		Vacuum pump (Turbo aut.)

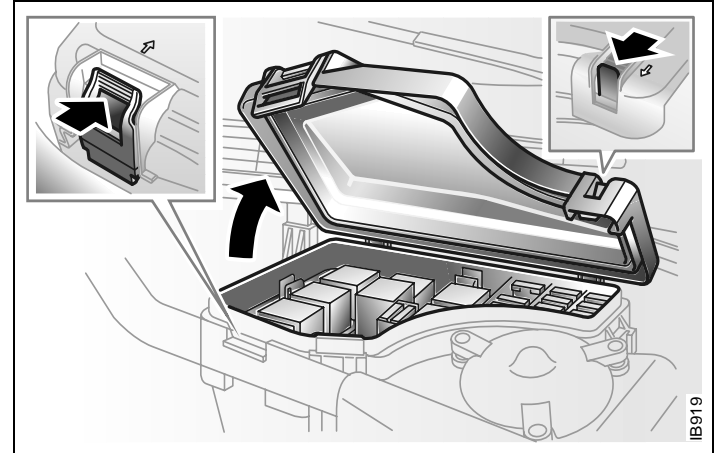

Fuses and relays in engine bay (left side)

D		Radiator fan, low speed
E		Lamp check (filament monitor, front)
F1	-	-
F2	-	-
G1		Horn
G2		Front fog lights
H		-
I		Radiator fan, high speed
J		A/C-compressor

Wheels

Alternative wheels and tires

If you wish to fit other tires or wheels than those supplied with the car, consult your Saab dealer first as to the possibilities available.

Wheels/tires combinations that are not approved by Saab can negatively affect the car's directional stability, steering and braking in both wet and dry conditions.

Do not assume that a wheel/tire combination will function properly just because it will bolt on.

NOTE

For wide wheels and/or low-profile tires, bear in mind the following:

- Tires and wheels can be damaged in potholes etc.
- Springs and shock absorbers can be overloaded.
- The wheels can come into contact with chassis and body components.
- The speed and load limits for the tires must not be exceeded; see page 193.
- Wheels larger than 16" must not be fitted on the Saab 9-3. For Viggen models the wheel should not be larger than 17". The maximum permissible offset for the 9-3 is 49 mm and for the Viggen 42 mm.
- When fitting wheels on a 9-3, please note that a 15" wheel should be used on 9-3 Coupé and 5-door models, and nothing smaller than 16" wheel should be used for Viggen models. Fitting a smaller size wheel on a Viggen is not possible due to the size of the brake discs.

The wheels and tires have been carefully matched to the characteristics of the car and play a key role in its outstanding roadholding and handling.

Tire pressure

NOTE

Check the tire pressures **at least once per month**.

Underinflation is the main cause of:

- Tires wearing out prematurely.
- Damage to the sidewalls.
- Damage to the wheels.

Tires need to be inflated to suit the load carried and the maximum speed the car will be driven (see the recommended tire pressures on the back cover). Note that all values apply to cold tires. For tires with an aspect ratio less than /60, increase the tire pressure by 3 psi (20 kPa) for rough roads with potholes to minimize the risk of rim damage.

Never reduce the pressure of a hot tire. If the tires are hot when you check them, only increase the pressure, if necessary.

Soft tires will cause faster wear than over-pressurized tires. They also increase fuel consumption.

If a valve is leaking, simply unscrew it and fit a new one.

Important! Remember to adjust the tire pressures if you change the load in the car or intend to cruise at a substantially higher or lower speed than normal.

Changing the wheels round

WARNING

When fitting just **one** new pair of tires, these should be fitted to the rear wheels, as these are more critical to the directional stability of the car (e.g. on braking or in a skid). The existing rear tires should therefore be moved to the front. Always move left rear to left front and right rear to right front, so that the direction of rotation remains the same.

Because of front wheel drive, the front tires tend to wear faster than the rear ones. New tires should always be fitted in pairs, so that tires on the same axle have the same amount of tread.

If swapping the complete set, e.g. winter tires for summer tires, mark the tires removed to ensure that they go back in the same position (e.g. FL for front left, RL rear left, etc.).

Store wheels lying flat or hanging – **never** standing upright.

Tire markings

An example of the meaning of the different markings in a tire size is given below for a tire size of 195/60 R15 88V:

- 195 Tire section width, mm
- 60 Aspect ratio, i.e. the section height is 60 % of the section width
- R Radial ply
- 15 Wheel rim diameter 15 in. at bead seats
- 88 Tire load code
- V Speed marking

Speed ratings

- S Tire approved for speeds up to 112 mph (180 km/h)
- T Tire approved for speeds up to 118 mph (190 km/h)
- H Tire approved for speeds up to 130 mph (210 km/h)
- V Tire approved for speeds up to 150 mph (240 km/h)
- W Tire approved for speeds up to 167 mph (270 km/h)
- Y Tire approved for speeds up to 186 mph (300 km/h)

Winter tires

Winter (snow) tires are recommended for winter climates where the majority of your driving will be done on snow and ice. Winter tires should be fitted to all four wheels to maintain a proper balance. Your Saab dealer can advise you of the correct size tire for your car (if different from the original size) and also supply Saab approved winter tires pre-mounted on steel or alloy rims.

Tire quality grading (cars sold in U.S.)

New tires must be graded and labeled in accordance with new Federal regulations. Standard tests are conducted to measure performance in the areas of traction and temperature resistance. Refer to the tire sidewall for the specific quality grades of the tires provided on your new Saab. Compact spare tires are exempt.

DOT QUALITY GRADES

- Treadwear.
- Traction AA, A, B, C.
- Temperature A, B, C.

All passenger car tires must conform to Federal safety requirements in addition to these grades.

Uniform Tire Quality Grading (US)

Quality grades can be found where applicable on the tire sidewall between tread shoulder and maximum section width. For example:

**Treadwear 200 Traction AA
Temperature A**

Treadwear

The treadwear grade is a comparative rating based on the wear rate of the tire when tested under controlled conditions on a specified government test course. For example, a tire graded 150 would wear one and one half (1 1/2) times as well on the government course as a tire graded 100. The relative performance of tires depends upon the actual conditions of their use, however, and may depart significantly from the norm due to variations in driving habits, service practices and differences in road characteristics and climate.

Traction

The traction grades, from highest to lowest, are AA, A, B and C. These grades represent the tire's ability to stop on wet pavement as measured under controlled conditions on specified government test surfaces of asphalt and concrete. A tire marked C may have poor traction performance.

 **WARNING**

The traction grade assigned to a tire is based on straight-ahead braking, traction test and does not include acceleration, cornering, hydroplaning or peak traction characteristics.

Temperature

The temperature grades are A (the highest), B, and C, representing the tire's resistance to the generation of heat and its ability to dissipate heat when tested under controlled conditions on a specified indoor laboratory test wheel. Sustained high temperature can cause the material of the tire to degenerate and reduce tire life. Excessive temperature can lead to sudden tire failure. The grade C corresponds to a level of performance which all passenger car tires must meet under the Federal Motor Vehicle Safety Standard No. 109.

Grades B and A represent higher levels of performance on the laboratory test wheel than the minimum required by law.

 **WARNING**

The temperature grade for a tire is established for a tire that is properly inflated and not overloaded. Excessive speed, underinflation, or excessive loading, either separately or in combination, can cause heat buildup and possible tire failure.

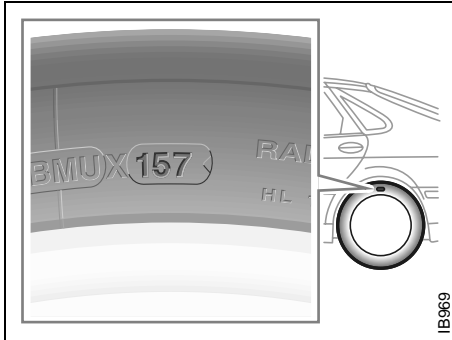

IB969

*Date code***Date code**

Tires should be regarded as perishable goods. As the tires age, the rubber becomes progressively harder, and the roadholding ability of the tires diminishes. This is particularly true on winter tires.

Tires now have a date-code marking for the year of manufacture. The first two digits denote the week number and the last digit the year. The "3" symbol points to the year. Accordingly, a date code of 157 signifies that the tire was manufactured in week 15, 1997.

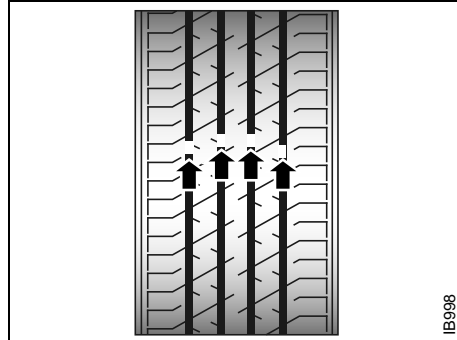

IB998

*Wear indicators***Wear indicators**

The tires incorporate wear indicators in the form of smooth, treadless strips across the width, which become visible when only 2/32" (1.6 mm) of tread remains. As soon as the indicators become visible, new tires should be fitted without delay.

Make sure you are familiar with the legal limit for minimum tread depth in your country and also any regulations governing the use of winter tires.

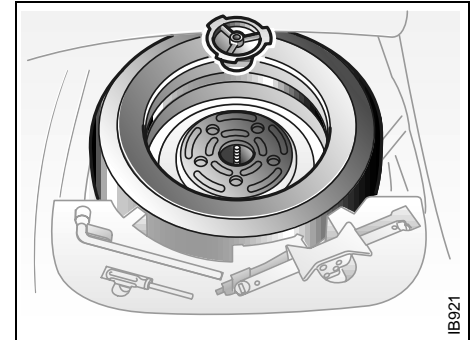

IB921

*Spare wheel (under the carpet in the trunk)***Compact spare wheel**

The compact spare is light and easy to handle when changing the wheel. Its use is only permitted when a standard wheel has sustained a puncture. The maximum life of the wheel is only 2000 miles (3,500 km).

Do not exceed 50 mph (80 km/h) with the compact spare fitted.

The compact spare should be inflated to 60 psi (420 kPa). Carry the punctured tire in the spare-wheel well under the trunk floor.

Have the standard wheel repaired and refitted as soon as possible

Driving considerations with compact spare wheel/tire fitted, see page 165.

The spare wheel, the tools and the jack with its crank are carried under a panel in the trunk.

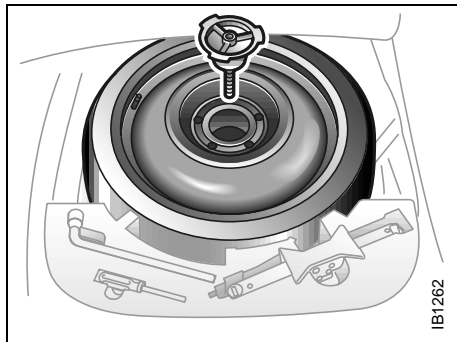

Spare wheel (under the carpet in the trunk), Saab 9-3 Viggen

When changing a wheel, take the tool kit out first, then the spare wheel.

NOTE

To avoid damaging a punctured alloy wheel this can be placed outside up in the spare-wheel well but **only** while driving to the closest workshop.

A general rule is that all heavy loads must be well secured in the luggage compartment, see page 129.

Changing a wheel

WARNING

- The car jack is designed solely for use in changing a wheel or fitting snow chains. It must not be used to support the car during repair work or servicing.
- Never crawl under a car that is supported only by a jack.
- Special care must be taken if the car is on a slope – use wheel chocks!
- Position chocks, one ahead and one behind, the wheel that is diagonally opposite to the one to be changed.
- Switch on the hazard warning lights if the car is on a road.
- Apply the parking brake and leave the car in gear (1st or reverse). Automatic transmission: move selector to the P position.
- Ensure that everybody is out of the car before jacking it up.
- Never start the engine while the car is jacked up.
- The jack must stand on a firm, level surface.

- Stow the jack in the place provided for it under the panel in the floor of the trunk. Secure it properly to avoid injury to passengers in the event of an accident.
- Do not use the jack for any purpose other than for jacking up the car.

If light-alloy wheels have been fitted to the car for several years and a change is made to steel wheels, the threads for the wheel bolts in the brake discs should be cleaned before the thinner steel wheels are fitted. The innermost threads in the holes may be clogged with sand, salt and rust so that the correct tightening torque cannot be achieved.

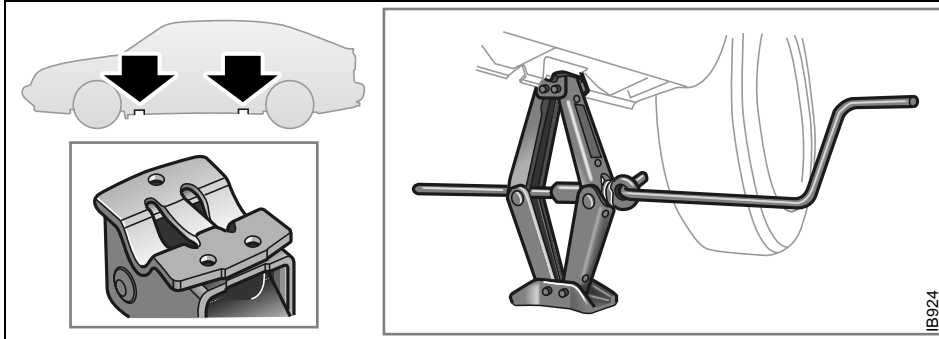

Position for jack

When it is time to raise the car, apply the jack to one of the four jacking points (front or rear) located beneath the sills.

If a floor jack is used it can be applied to the standard jacking points used by the dealer or centrally under the front of the engine subframe. If the car is equipped with a trailer hitch, the jack can also be placed under the hitch.

NOTE

Do not position the jack under the rear axle or under the rear floor.

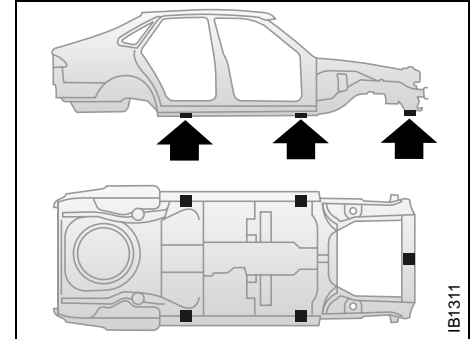

Jacking points for a floor jack.

- 1 Put the car in 1st gear (automatic transmission: move selector to the P position) and apply the parking brake.
Saab 9-3 Viggen: The front and rear jacking points are located behind covers that must be removed.
- 2 Wind the jack up to a suitable height before placing it under the recess in the sill.
- 3 Make sure that the jack fully engages the recess in the sill and that the base of the jack is steady and flat on the ground.
- 4 Turn the jack handle clockwise until it just begins to lift the car.
- 5 Remove the wheel cover (where applicable). Loosen the wheel bolts by half a turn.
- 6 Turn the jack handle to raise the wheel clear of the ground. Remove the wheel bolts and lift off the wheel.
- 7 Fit the wheel and screw in the bolts in the sequence shown (opposite pairs). Tighten the studs enough for the studs and wheel to be seated correctly. See page 199 for sequence.

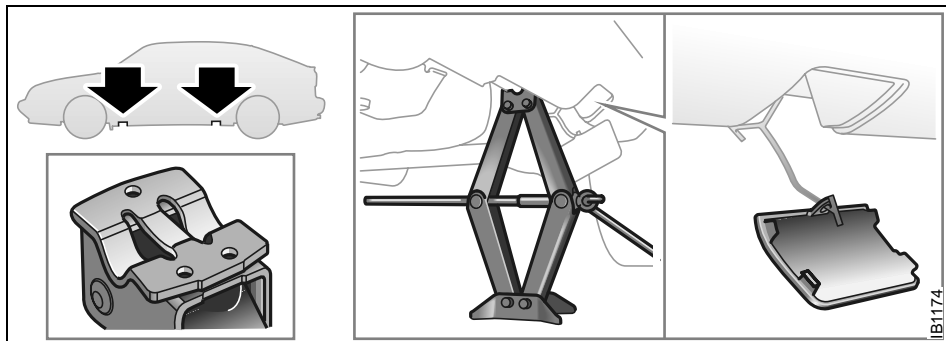

Position for jack, Saab 9-3 Viggen

- 8 Lower the car and tighten the wheel bolts to the correct torque in the sequence shown (opposite pairs).

Tightening torque:

Light-alloy wheels: 80 ft.lbs (110 Nm).
Steel wheels: 80 ft.lbs (110 Nm).

Do not overtighten the bolts using an impact wrench: not only can this damage the wheels but it can also make it impossible to undo the bolts using the wheel wrench in the car's toolkit.

- 9 Recheck the wheel bolts after a few miles.

Tightening torque:

Light-alloy wheels: 80 ft.lbs (110 Nm)
Steel wheels: 80 ft.lbs (110 Nm)

We advise against using wheels with open wheel covers in winter, as the brake components are then more exposed both to slush and to road salt and grit.

Tire chains; see page 155.

NOTE

Saab 9-3 Viggen: The minimum permissible wheel diameter is 16", due to the size of the brake discs.

NOTE

When refitting wheel covers (where applicable), make sure that the valve protrudes through the hole in the wheel cover.

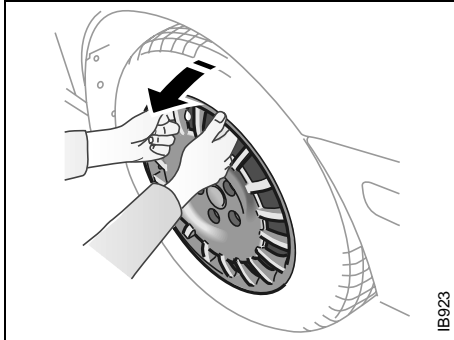

IB923

Removing the wheel cover

Flat spotting

All tires get hot, especially on long journeys or when the car is driven hard. After the car has been parked with hot tires and the tires have cooled down, a flat spot can form in the tire, where it is in contact with the ground. The same can occur if the car has not been moved for a long time.

Flat spots can cause vibration that can be felt through the steering wheel, similar to that experienced when the wheels need balancing. Flat spots of this type disappear once the tires get hot again, usually after 10–15 miles (20–25 km) of driving at cruising speed.

Tightening sequence, wheel bolts

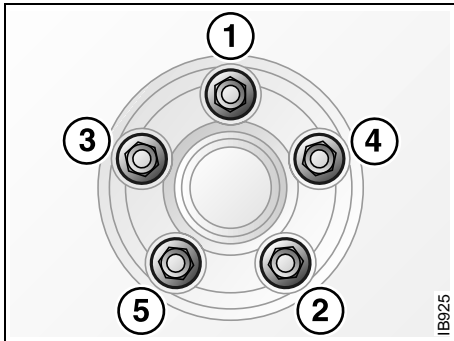

IB925

Safety belts



Safety belts and belt pretensioners that were in use in a serious collision must be replaced even if they are not visibly damaged.

No attempt must be made to repair, or modify the function of, safety belts.

A check should be made periodically to ensure that the safety belts are working properly.

- Hold the diagonal strap and pull it sharply. The seat belt should lock and it should not be possible to withdraw it further.

A sharp tug on the belt should cause the inertia reel to lock. Check the floor anchorage points for corrosion damage. If a belt is worn or has any fraying edges, it should be replaced.

Safety belts must not come into contact with substances such as polishes, oil or chemicals. If the belts get dirty, wash them with warm water and a detergent or have them replaced.

Upholstery and trim

To remove fluff or hairs from the seat upholstery or headlining, use a moist, lint-free cloth or a special lint remover (brush or roller). Remove any dirty marks using a cloth moistened with lukewarm soapy water.

When using a stain remover, always work from the outside towards the center to avoid leaving a ring. If a soiled ring or spot should remain, it can usually be removed using lukewarm soapy water or water alone.

Wet patches left by spilled soft drinks or thin oil must be wiped off immediately using an absorbent material, such as paper toweling, and treated with stain remover.

Isopropyl alcohol is recommended for removing grease or oil stains, and a semi-stiff brush may also be used.

Cleaning and caring for leather upholstery

The principal reason for treating leather upholstery is to maintain its elegant appearance and to provide it with a protective film. Discoloration caused by dust and wear mainly affects the lighter shades, although this is not detrimental to the leather – indeed, the patina resulting from use is often considered desirable in leather. But if the leather is allowed to become too grubby, it can start to look shabby.

It is a good idea to clean and recondition the leather twice a year – in conjunction with a general spring-cleaning of the car – after the winter and in the autumn, for instance. In hot, dry climates, the leather will need to be treated more frequently.

Moisten a soft cloth in a mild soap solution. Carefully apply this damp (not wet) cloth to the leather, working in light, circular movements until the leather is clean. Repeat the procedure using clean water and then leave the leather to dry thoroughly. Finally, treat the leather with a conditioner.

Apply the leather conditioner using a soft cloth and the same circular movements as described above. After it has dried, polish the leather with a soft, dry cloth. Follow the directions given above. Do not use hot water, unknown abrasive polishes, solvents, sprays or soaps that might scratch the leather. Look after the leather as described and it will stay clean and attractive for many years.

Textile carpeting

Vacuum clean the carpeting regularly. Carpets can also be cleaned using a brush, or carpet shampoo applied with a sponge. Do not use vacuum cleaners outdoors unless they are properly grounded.

Engine bay

Clean the engine compartment using an engine detergent and rinse with hot water. Cover the headlights and do not aim the spray nozzle on the:

- Radiator.
- Throttle cable.
- Throttle housing.
- Other engine controls.
- The alternator.
- Ignition system and other electrical components.

Avoid spraying the hood liner, as this can become heavy and hang down and touch the engine when the hood is closed.

Additional care should be taken if using a high-pressure washer. Hold the nozzle at right angles to the area to be cleaned. This is particularly important when spraying labels.

Do not use gasoline as a cleaning agent or solvent when carrying out repairs or maintenance. Saab recommends the use of environmentally safe degreasing agents.

Washing

Wash the car frequently. When the car is new, wash the bodywork by hand, using just cold water – a brush attachment on the end of a hose is ideal. Do not use automatic car washes for the first five or six months, before the paintwork has hardened properly. Thereafter, use a high quality car wash soap added to lukewarm water.

Remove any bird droppings without delay, as these can discolor the paintwork and prove difficult to polish out.

Use a soft cloth moistened with methyl alcohol to remove splashes of tar or asphalt. Do not use strong cleaners, as these can dry out the paintwork.

NOTE

Avoid using any alcohol-based cleaners on the front and rear light clusters, as these can cause cracking of the lenses.

The underside of the car also needs washing regularly, and this should be done very thoroughly at the end of winter. Clean the underside of the car by hand if the car is usually washed in an automatic car wash without special facilities for underbody cleaning. Never wash or leave the car to dry in the sun, but wipe it dry with a chamois leather immediately after washing to avoid smears and streaks.

Clean the window glass inside and out using a high quality window cleaner. This is particularly important when the car is new, as upholstery and trim have a tendency to sweat a little at first.

Keep the glass well cleaned, as this helps to prevent misting.

NOTE

- Try your brakes on leaving a car wash. Wet brake discs reduce the braking effect.
- Turn off the radio before entering an automatic car wash so the power antenna mast does not get damaged.
- Clean the rod of the electrically powered antenna about once a month with a clean, dry rag.
IMPORTANT! Use no oil, nor any silicone-based cleaning product.
- Fixed antennas must be removed when going through an automatic car wash.
- **Saab 9-3 Viggen, Coupé and 5-door:** If you wash the car in an automatic car wash, you must first remove the roof-mounted antenna, otherwise it will be damaged.
- On Convertible models with OnStar, fold down the cellular antenna mounted on the windshield before entering a car wash to avoid damage to the antenna or convertible top.

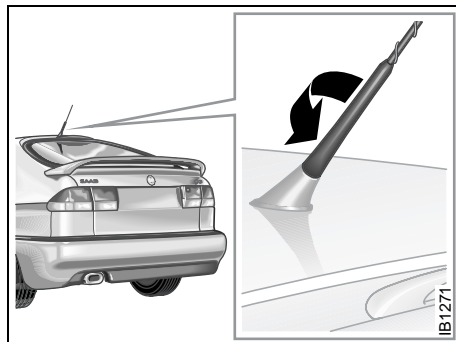

Removing the roof-mounted antenna, Saab 9-3 Viggen Coupé and 5-door

Waxing and polishing

Do not wax a new car during the first three or four months. In fact, there is no need to polish the car before the paintwork has started to go dull through oxidation. Other than in exceptional cases, do not use abrasive polishes containing a cutting agent on a new car. Always wash the car thoroughly before waxing or polishing.

Touching up the paint

Damaged paintwork should be treated as soon as it is discovered: the longer it is left, the greater the risk of corrosion. The anti-perforation warranty does not cover corrosion resulting from untreated defects. Paintwork damage sustained in a collision is usually extensive and can only be properly restored by professionals.

However, you can repair small scratches and stone-chip damage yourself. The necessary tools and materials, such as primer, touch-up paint and brushes, are available from your Saab dealer.

In the case of minor flaws in the paintwork, where the metal has not been exposed and an undamaged layer of paint remains, touch-up paint can usually be applied directly, after any dirt has been scraped away using a pointed knife.

If corrosion has already set in, e.g. as a result of stone-chip damage, use a pointed knife to scrape off all surface rust. If possible, the damaged area should be taken back to the bare metal. The metal should then be primed with two thin coats of primer applied by brush.

After the primer has dried, apply several thin layers of topcoat enamel until the surface of the repaired area is flush with the surrounding paintwork.

Stir both primer and touch-up enamel thoroughly before use and allow each coat to dry before applying the next.

Two-coat enamel

As the name implies, two-coat enamel is applied in two operations. The first coat, the base color, contains the pigment, metal flakes and binder. The second coat consists of a clear enamel, which provides the final gloss for the paintwork and protects the base from moisture and environmental contaminants.

Touch-up stone-chip damage as follows:

- 1 Thoroughly clean the damaged area.
- 2 Then apply the primer, base color, and finally, the enamel. To achieve the best finish, apply two or three coats of primer.

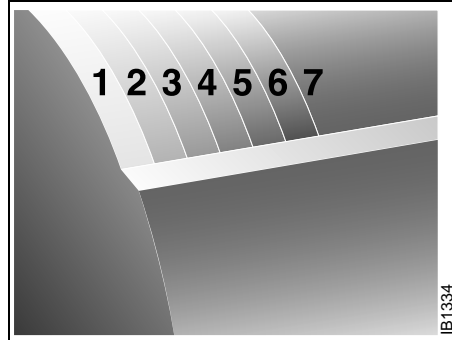

Surface-treatment composition

- 1 Body panel
- 2 Zinc (certain parts) 7.5 μm
- 3 Phosphate coating
- 4 Cathodic ED 28 μm
- 5 Intermediate coat 35 μm
- 6 Metallic base/solid base 15 μm
- 7 Clear enamel 40 μm

Anti-corrosion treatment

The entire car is corrosion-protected at the factory in different stages by an electrolytic immersion coating and a polyester-based protective coating to protect against corrosion caused by stones flung up by the wheels. A thin penetrating anti-rust oil is also applied in cavities and body members.

In addition to conventional anti-corrosion treatment like painting, underbody treatment and cavity treatment, most of the body panel surfaces are galvanized. These include the hood, the doors and the underbody.

The anti-corrosion treatment on the underside of the car and inside the wheel arches is particularly exposed to constant wear and possible damage, the degree of which will obviously depend on driving conditions.

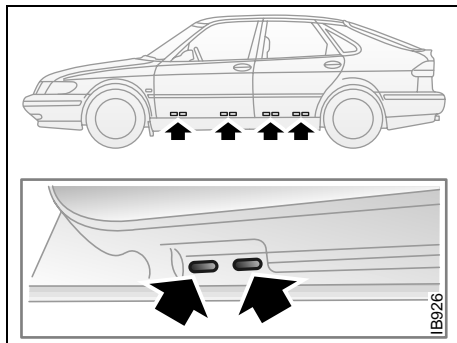

Drainage holes in doors

What causes rust?

Steel body panels of automobiles are subject to rusting whenever air and moisture manage to penetrate the protective finish. Body panels may rust through if the process is unchecked. Rusting can occur wherever water is trapped or where the car's panels are continuously damp.

Damage to paint and undercoating by stones, gravel and minor accidents immediately exposes metal to air and moisture. Road salts used for de-icing will collect on the bottom of the car and promote rusting. Areas of the country with high humidity have a greater potential for rust problems, especially where salt is used on roads or there is moist sea air. Industrial pollution (fallout) may also damage paint and promote rusting.

Preventive maintenance

The following procedures are necessary to help protect against rusting. Refer also to the terms and conditions of the Performance Limited Warranty described in the warranty booklet.

- 1 **Wash the car frequently, and wax at least twice a year.** Under adverse conditions, where there is a rapid buildup of dirt, sand or road salt, wash your car at least once a week. After extreme exposure to salted snow or slush, evidenced by a white film on the car, wash the car immediately. Frequent washing will prevent paint damage from acid rain and other airborne contaminants such as tree sap and bird droppings. If any of these contaminants are noticed on the car the finish should be washed immediately.
 - Begin washing by rinsing the entire car with water to loosen and flush off heavy concentrations of dirt (include the underbody).
 - Sponge the car with a solution of either a good quality car soap or mild general purpose (dish washing) detergent and water.
 - Rinse car thoroughly with clean water.
 - After washing, check and clear all drains in doors and body panels.
 - Wipe the car dry, preferably using a chamois.

2 **Clean the underside of the car during the winter.** Use high pressure water to clean the car's underside (floor panels, wheel wells) at least at mid-winter and in the spring.

3 **Inspect the car frequently for leaks or damage, and arrange for needed repairs promptly.** After washing or after heavy rain, check for leaks. When washing the car inspect body surfaces for paint damage. While checking for leaks, lift the floor mats and check underneath them. Water can collect in these areas and remain for prolonged periods. Dry any wet areas including the floor mats. Have leaks repaired as soon as possible.

Use touch-up paint to repair small scratches or minor finish damage. Areas where metal is exposed will rust quickly and **MUST** be repaired immediately by touch-up or professional repainting. Rust must be removed, the bare metal primed and painted. Major body damage should be repaired immediately and new panels or exposed areas should be undercoated with anti-corrosion material.

Repairs of this type are the owner's responsibility and are not covered under warranty.

Inspect the undercoating and touch up if necessary. Pay particular attention to the fenders and wheel housings, which are exposed to abrasion by flying gravel, etc. If the composition has worn or flaked off, the steel must be thoroughly cleaned and dried before a fresh coat is applied. The cleaning is best done with a scraper and a steel wire brush, followed by washing with solvent. Apply the new coating thinly, otherwise it may run off or fall off when dry.

Recovery and/or recycling of automotive materials

A typical car consists of metals (65–75%), plastics (10–14%), rubber (5%) and small quantities of glass, wood, paper and textiles.

Some of these materials can be recycled, while others can be recovered in chemical processes for reuse in new products or as a source of energy.

While the Saab 9-3 was still at the drawing-board stage, Saab engineers were giving serious consideration to how the maximum quantity of materials could be reclaimed from the car on its eventual scrapping. To facilitate sorting, plastic parts, for instance, have been marked to identify the precise nature of the plastic.

Approximately 90% of the materials in the car can be recycled or recovered, where facilities exist.

Before the car is scrapped, all the oils and other fluids that could pollute the environment should be recovered from the car. It may be of interest in this context to learn that the refrigerant used in the Saab 9-3's A/C and ACC systems (R134a) contains neither CFCs nor any other chlorine compounds

- 1 A-pillar trim: PP, PP/EPDM.
- 2 Windshield trim: PP, PP/EPD.
- 3 Seals: EPDM.
- 4 Rear-window casing PUR.
- 5 Trim panel ABS.
- 6 C/D-pillar trim PP.
- 7 Rear light cluster: PMMA.
- 8 Corner filler panel PPO/PA.
- 9 Rear bumper
Expanded PP core
PP/EPDM sheathing.
- 10 Fuel tank PE.
- 11 Side-window casing:
PP/EPDM.
- 12 Side trim PVC.
- 13 A-pillar upholstery trim:
PC/ABS, textile.
- 14 Rearview mirror: ABS.
- 15 Sill scuff plate: PP/EPDM.
- 16 Wheel-arch liner: PP.
- 17 Wheel cover: PA.
- 18 Direction-indicator lamp lens: PMMA.
- 19 Front spoiler: PP/EPDM.
- 20 Front bumper,
cellular core, expanded PP,
sheathing: PP/EPDM.
- 21 Fan shroud: PP.
- 22 Radiator grille: ABS.
- 23 Washer-fluid reservoir: PE.
- 24 Cowl trim: PC/ASA.

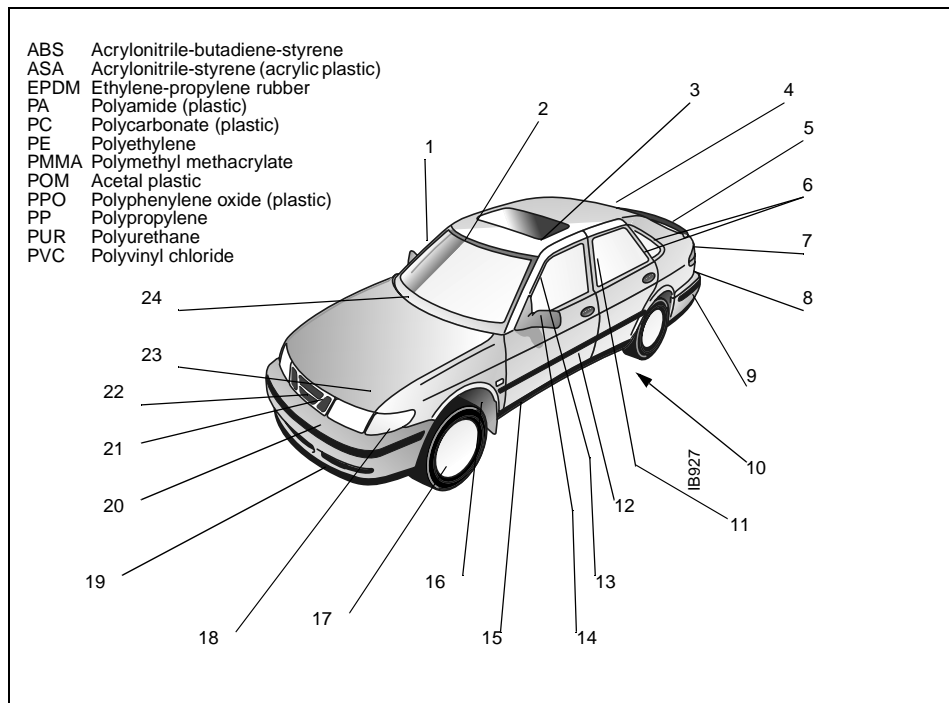

Air conditioning (A/C system)

NOTE

- The A/C system is designed for use with R134a refrigerant.
- Refrigerant handling requires special equipment and special procedures for charging and draining the system.
- All repairs and adjustments on the A/C system must be carried out by a Saab dealer authorized for this kind of work.
- Never mix R134a and R12 refrigerants.



WARNING

- The A/C system is pressurized. Do not break any connections or undo A/C system components.
- Escaping refrigerant gas can cause blindness or other injury.

Fault diagnosis

If a fault occurs in the A/C system, there are a number of checks you can perform yourself. If the fault persists, however, have the system checked by an authorized Saab dealer.

Important!

When the A/C system is in operation, moisture from the air will condense on the evaporator. When the car is then parked, this condensation will drip off the evaporator and form a small pool of water on the ground. This is normal. The warmer the ambient air and the higher the humidity, the greater the amount of condensation formed.

Inadequate cooling:

- Make sure that the temperature and air-distribution controls are in the appropriate settings, see page 77.
- Check that the condenser (forward of the radiator) has not become clogged with dirt and insects.
- Make sure that the drive belt for the compressor is not slipping, see page 179.
- Check the fuses for the ventilation fans and compressor, see page 189.

Maintenance

- The drive belt for the compressor should be inspected under the regular service program.
- Clean dirt and insects away from the condenser and radiator to prevent clogging. When washing the car, use the hose to spray the radiator and condenser (located forward of the radiator) from both sides (both from the front of the car and from inside the engine bay). Do not use a pressure washer.

Caution: Do not use the hose when the engine is hot.

Other than in extremely cold weather, do not cover the radiator, e.g. with screen netting, as this will greatly diminish its cooling capacity.

Note: The A/C system will only operate when the outdoor temperature is above the freezing point (0°C, 32°F). Switch on the A/C system when the car stands in a warm place.

Headlight aiming



Before checking/adjusting the headlight aiming, switch off the engine to avoid danger of fingers and hands being injured by moving parts.

The radiator fan can start up even when the engine is switched off.

The vehicle is equipped with vertical and horizontal aim indicators. The aim has been preset at the factory and should normally not need further adjustments. This is true even though your vertical and horizontal aim indicators may not fall exactly on the "0" (zero) marks on their scales.

If your headlight is damaged in an accident, the headlight aim may be affected. If you believe your headlights need to be re-aimed, we recommend that you take it to your Saab dealer for service. However, it is possible for you to re-aim your headlights as described in the following procedure.

To check the aim, the vehicle should be properly prepared as follows:

- Place the vehicle on a level pad or surface
- The vehicle should be unladen and fuel tank full, and one person or 160 lbs. (75 kg) on the drivers seat
- The vehicle should not have any snow, ice or mud attached to it
- Tires should be inflated to the prescribed pressure
- Rock the vehicle to stabilize the suspension

Open the hood and locate the vertical aim level (B) that you can see through the top of the headlight lens.

If you find that the headlight needs adjustment follow these steps:

- 1 Locate the vertical aiming device (A) located behind and below the outer headlight assembly.
- 2 Turn the vertical aiming screw with a 0.24 in. (6 mm) Hexagonal Allen wrench until the bubble inside the level is centered between the two red lines (zero).
- 3 Check the horizontal aim (1) and adjust as necessary. The horizontal aiming device (2) is located behind the inner headlight assembly. Turn the horizontal aiming knob until the zero (0) line on the knob aligns with the zero mark on the graduation scale.
- 4 Recheck the vertical aim to make sure it is still correct after the horizontal aim adjustment. Readjust as necessary.

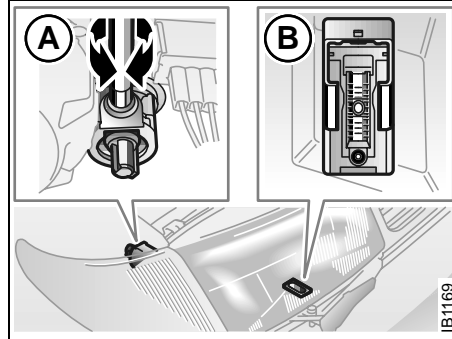

Vertical adjustment

- A Vertical aiming device
- B Vertical aim level

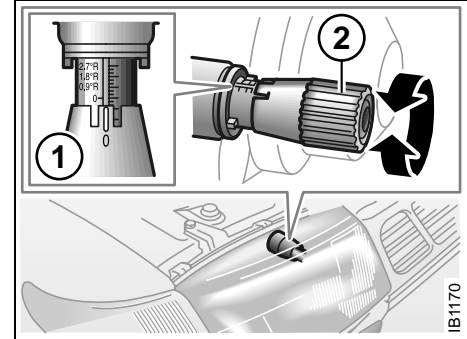

Horizontal adjustment

- 1 Horizontal aim
- 2 Horizontal aiming device

NOTE

To make sure that your headlights are aimed properly read all instructions before beginning. Failure to follow these instructions could cause damage to headlight parts or a not correctly aimed headlight.

Maintenance and owner assistance

Maintenance schedule.....	212
Owner assistance	213
Reporting Safety Defects (U.S.A.)	214
Reporting Safety Defects to the Canadian government	214
Saab Original Service Program M2000 USA, Canada, (9-3 Models)	215

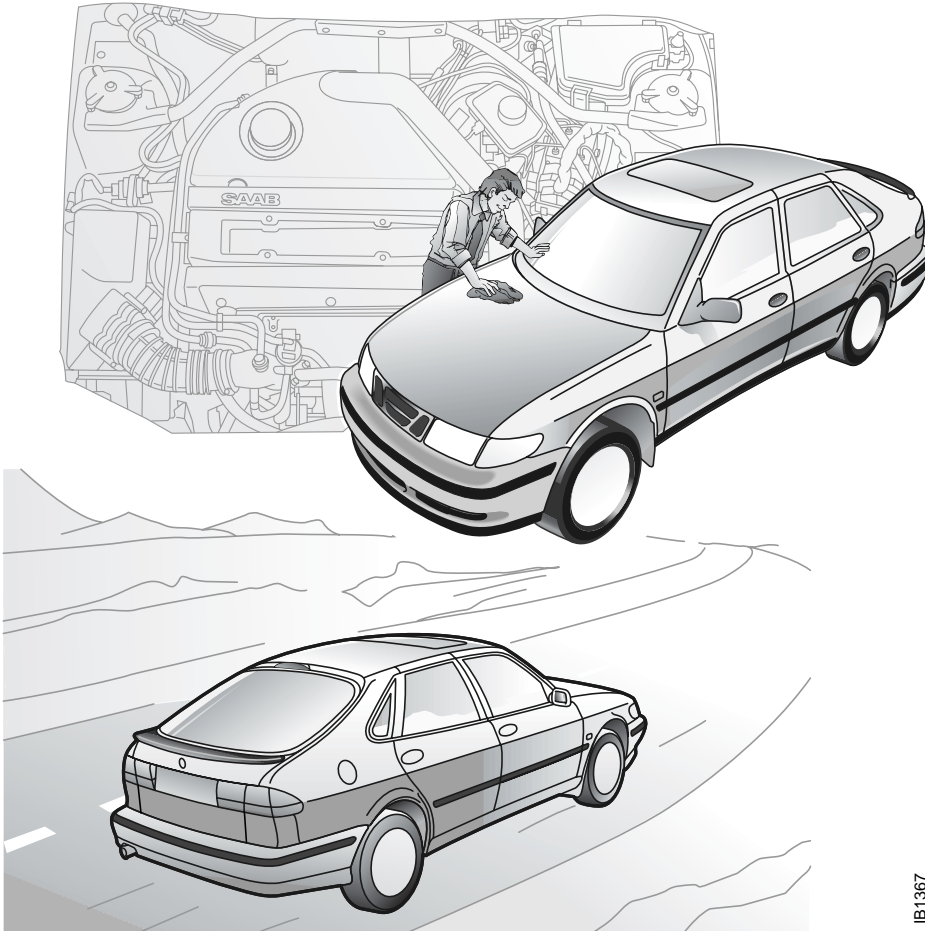

Maintenance schedule

The Maintenance Schedule prescribes a service program to the purchaser/operator of a Saab that is reasonable and necessary to ensure the proper emission control systems function, safety and reliability of the Saab automobile in normal use. Additional maintenance is recommended for specific components when the car is operated under certain severe conditions. Proper maintenance is always a good practice!

Authorized Saab dealers are equipped and trained to meet your Saab's service needs. They regularly receive up-to-date Saab service manuals and parts and technical service bulletins from Saab and are able, through their franchise agreement, to attend Saab service schools, obtain Saab special tools and technical assistance and purchase original equipment service and replacement parts.

Today's complex automobiles should only be entrusted to the most knowledgeable service professionals. A Saab dealer is your best choice.

Service intervals

The maintenance schedule is comprised of a "First Service" at 1,000 miles (1,600 km), followed by services at every 10,000 miles (16,000 km) thereafter (20,000, 30,000 miles/32,000, 48,000 km etc.).

NOTE

The "First Service" will be done by your Saab dealer at no charge and should be done as close as possible to the scheduled mileage (1,000 miles/1,600 km). The engine oil and filter must be changed at this service.

Engine oil and filter changes

Changing the engine oil and filter is required at every service point. Use only a Saab approved long-life oil filter and engine oils meeting the SAE viscosity ratings and API service classifications stated in the "Technical data" section of this Owner's Manual. The use of extra additives in the oil is not necessary and is not recommended, and may be harmful to turbochargers.

More frequent oil changes are recommended if your vehicle is operated under any of the following conditions:

- Most trips are less than 5-10 miles (8-16 km). This is particularly important when outside temperatures are below freezing.
- Most trips include extensive idling (frequent stop-and-go traffic).
- Most trips are through dusty areas (such as construction zones).
- If the vehicle is used for delivery service, police, taxi or other commercial applications.

If your driving habits match this description, have the engine oil and filter changed in-between normal services at 5,000 mile (8,000 km) intervals. These conditions cause the engine oil to break down faster. The Warranties and Service Record Booklet has provisions to record extra oil changes.

Service record retention

Service instruction coupons and record stubs are provided in the Saab Warranties and Service Record Booklet which accompanies this Owner's Manual. The coupons are arranged in the order that normal service should be performed. The edge of each coupon is shaded to correspond to the type of service point:

- Striped - "First Service".
- Blue - Oil change/inspection service.
- Black - Major service.

Note that in Canada a combined service and warranty book is used, but not service coupons.

When scheduled services are performed, your dealer will tear out the applicable coupon and use it to check off the operations performed and enter it into the service file at the dealership. The servicing dealer's stamp, along with the date and mileage at which the service was done, should be entered on the corresponding stub which remains in your booklet. The booklet is your permanent record of the services performed. It also includes a log sheet for unscheduled repairs.

It is advisable to retain receipts and, if possible, copies of shop work orders for all service and repair work, wherever performed.

Service costs

Dealer pricing practices and labor for service work vary. Saab's recommended service times for each service point do not include the labor required to replace wear items, such as wiper blades, brake pads or tires. Nor is labor to perform other service or repairs found to be necessary as a result of the inspections included in these times. Additional labor and parts will be charged for such work when necessary, except as covered under an applicable Saab warranty or any optional extended service contract. Transmission fluid changes or suspension alignment, when necessary, are also additional.

Dealer charges for general shop material, regulated hazardous waste removal, recycling expenses or other operation costs may also be applied to service and repair invoices and are apt to vary by dealer and location.

Owner assistance

Warranties and service problem assistance

For complete information about all applicable warranties, including the New Car Warranty, Perforation Warranty, Vehicle Emission Warranty and Emission Perforation Warranty, consult the Warranties and Service Record Booklet which accompanies this Owner's Manual. It also contains owner assistance information including Saab Roadside Assistance. If the booklet is lost or misplaced, a new one may be ordered through a Saab dealer or by contacting Saab.

In the U.S. there is a national Customer Assistance Center at Saab Cars USA, Inc. The toll-free number to call from all 50 states is 1-800-955-9007.

In Canada, please call the Saab Customer Assistance Centre at 1-800-263-1999.

A list of authorized Saab sales and service dealers is available for those planning to travel in the United States and Canada.

Canadian or U.S. travelers may call the Customer Assistance Center in the country in which they are traveling.

Change of Address Notification (U.S.)

Two change of address cards are provided at the end of the Warranties and Service Record Booklet. Knowing your current address allows Saab to contact you in the event of a recall or service campaign. Please help us keep our records up to date for your own peace of mind.

Service information

Factory Service Manuals for the Saab 9-3 and 9-5 car lines can be ordered through the dealer. These are comprehensive manuals comprised of several sections in multiple ring-type binders, geared to use by professional technicians.

Sections may be ordered individually. Consult your Saab dealer for prices and for a listing of available sections for your model.

Reporting Safety Defects (U.S.A.)

If you believe that your vehicle has a defect which could cause a crash or could cause injury or death, you should immediately inform the National Highway Traffic Safety Administration (NHTSA) in addition to notifying Saab Cars USA, Inc.

If NHTSA receives similar complaints, it may open an investigation, and if it finds that a safety defect exists in a group of vehicles, it may order a recall and remedy campaign. However, NHTSA cannot become involved in individual problems between you, your dealer, or Saab Cars USA, Inc.

To contact NHTSA, you may either call the Auto Safety Hotline toll-free at 1-800-424-9393 (or 202/366-0123 in Washington D.C. area) or write to: NHTSA, U.S. Department of Transportation, Washington, D.C. 20590. You can also obtain other information about motor vehicle safety from the Hotline.

Reporting Safety Defects to the Canadian government

If you live in Canada, and believe that your vehicle has a safety defect, you should immediately notify Transport Canada, in addition to notifying General Motors of Canada Limited.

You may write to Transport Canada at Box 8880, Ottawa, Ontario, K1G 3J2.

In addition to notifying Transport Canada in a situation like this, we certainly hope you will notify us. In Canada, please call our Saab Customer Assistance Centre at 1-800-263- 1999.

Or write:

General Motors of Canada Limited
Customer Assistance Centre,
1908 Colonel Sam Drive,
Oshawa, Ontario, L1H 8P7.

Saab Original Service Program M2000 USA, Canada, (9-3 Models)

Service Intervals ** Miles = U.S. Cars Kilometers = Canadian Cars	10,000 (16,000 km)	20,000 (32,000 km)	30,000 (48,000 km)	40,000 (64,000 km)	50,000 (80,000 km)	60,000 (96,000 km)	70,000 (112,000 km)	80,000 (128,000 km)	90,000 (144,000 km)	100,000 (160,000 km)	
Service #	1	2	3	4	5	6	7	8	9	10	11

Engine and engine compartment

E	Engine oil and filter (a.)	■	■	■	■	■	■	■	■	■	■	■	■	■	■	■
R	Engine coolant freezing point and level	○	○	○		○	○	○	○	○	○	○	○	○	○	○
R	Engine coolant flush and replace (max. 3-year intervals)				■			■					■			
R	Engine cooling system, hoses and cap		○	○	○	○	○	○	○	○	○	○	○	○	○	○
R	Drive belt; condition		○	○	○	○	○	■	○	○	○	○	○	○	○	○
E	Spark plugs				■*			■*						■*		
E	Crankcase ventilation and vacuum lines							○						○		

* These are the minimum required Emission Control System maintenance steps. Saab urges that all recommended maintenance procedures be performed according to this program.

(a.) Engine oil and filter should be changed at least once a year. Intermediate oil and filter changes (halfway between indicated intervals) suggested for cars primarily used for driving in dense city traffic or for repeated short trip operation without sufficient warm up.

** **Service intervals:** Refer to the Warranties & Service Record Book for service intervals beyond 100,000 miles (160,000 km).

Application/type of service (col. 1)
E = emission service
R = regular maintenance

Service Procedure
○ = Check - top up, adjust or replace if necessary
■ = Replace
● = Lubricate

Service Intervals ** Miles = U.S. Cars Kilometers = Canadian Cars	1,000 (1,600 km)	2,000 (3,200 km)	3,000 (4,800 km)	4,000 (6,400 km)	5,000 (8,000 km)	6,000 (9,600 km)	7,000 (11,200 km)	8,000 (12,800 km)	9,000 (14,400 km)	10,000 (16,000 km)
	1	2	3	4	5	6	7	8	9	10

Chassis

R	Ball joint clearance, outer and inner steering joints and rubber boots		○	○	○	○	○	○	○	○	○	○	○	○	○
R	Front suspension, rear axle mountings; retighten	○													
R	Shock absorbers and bushes; tightness and condition				○			○					○		
R	Tire pressure, tread depth and wear (c.)	○	○	○	○	○	○	○	○	○	○	○	○	○	○
R	Rotate tires, front to rear		○	○	○	○	○	○	○	○	○	○	○	○	○
R	Brake pads and discs; wear and condition (d.)		○	○	○	○	○	○	○	○	○	○	○	○	○
R	Brake lines and hoses	○	○	○	○	○	○	○	○	○	○	○	○	○	○
R	Brake fluid level & renewal (max. 2-year intervals)	○	○	○	■	○	○	■	○	○	○	○	■	○	○
R	Check parking brake function	○	○	○	○	○	○	○	○	○	○	○	○	○	○
R	Power steering fluid level	○	○	○	○	○	○	○	○	○	○	○	○	○	○

(c.) Check wheel alignment if irregular or premature tire wear is apparent.

(d.) Check and clean rear pads and rear calipers in areas with heavy road salt use.

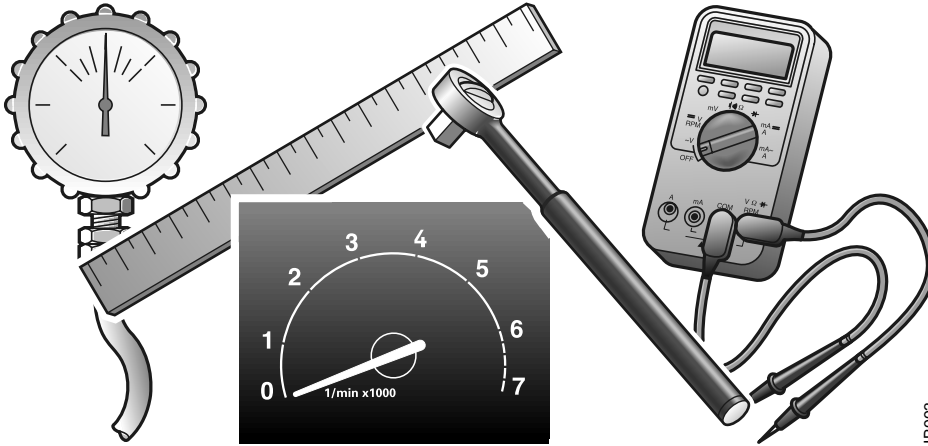

IB993

Technical data

General particulars	220
Engine	223
Engine oil.....	223
Engine variants	225
Electrical system.....	225
Drive belts.....	225
Manual transmission	226
Automatic transmission ..	226
Suspension.....	226
Steering.....	226
Brake system.....	227
Rims and tires	227
Plates and labels.....	229

General particulars

Overall length, with bumper(s):	
Coupé/5-door/Convertible _____	182.3" (4629 mm)
Viggen _____	182.7" (4639 mm)
Overall width, including door mirrors _____	76.2" (1936 mm)
Maximum height _____	56.2" (1428 mm)
Maximum height when the soft top is being operated (Convertible) _____	approx. 87" approx. 2200 mm
Wheelbase _____	102.6" (2605 mm)
Track:	
front, Coupé/5-door/Convertible _____	57.2" (1452 mm)
front, Viggen _____	57.7" (1466 mm)
rear, Coupé/5-door/Convertible _____	56.8" (1442 mm)
rear, Viggen _____	57.3" (1456 mm)
Ground clearance at max. weight _____	approx. 3.9" (100 mm)
Number of occupants, incl. driver:	
Coupé and 5-door _____	5
Convertible _____	4
Turning circle:	
measured at vehicle extremities _____	36.4 ft. (11.1 m)
curb to curb _____	34.4 ft. (10.5 m)

Gross vehicle weight (GVW)

Maximum train weight (GVW + max. trailer weight)

Maximum axle load, front

Maximum axle load, rear

Permissible load (in addition to the driver) = GVW minus curb weight. The maximum permissible axle load, front or rear, must not be exceeded. The precise curb weight of the vehicle (weight ready for driving + driver á 154 lbs. (70 kg) and load capacity are specified in the vehicle registration documents.

Chassis number plate in engine bay

Length of the trunk:

rear seat raised, Coupé- and 5-door car	37.0" (940 mm)
rear seat lowered, Coupé- and 5-door car	67.2" (1705 mm)

Volume of trunk according to SAE:

with parcel shelf, Coupé- and 5-door car	15.9 cu.ft. (451 dm ³)
whole rear seat tipped forward, Coupé- and 5-door car _____	46.0 cu.ft. (1303 dm ³)
Convertible, soft top up _____	12.5 cu.ft. (354 dm ³)
Convertible, soft top down _____	10.1 cu.ft. (285 dm ³)

Weight ready for driving (i.e. with full fuel tank, washer- fluid reservoir, standard tools and spare wheel)

Coupé _____	2990-3170 lbs. (1355-1440 kg)
Viggen, Coupé _____	3090-3160 lbs. (1405-1435 kg)
5-door _____	3030-3220 lbs. (1375-1460 kg)
Viggen, 5-door _____	3140-3210 lbs. (1425-1455 kg)
Convertible _____	3130-3260 lbs. (1420-1480 kg)
Viggen, Convertible _____	3220-3230 lbs. (1460-1465 kg)

Gross vehicle weight (GVW)

Coupé _____	3930-4060 lbs. (1785-1840 kg)
Viggen, Coupé _____	4060 lbs. (1840 kg)
5-door _____	3980-4100 lbs. (1805-1860 kg)
Viggen, 5-door _____	4100 lbs. (1860 kg)
Convertible _____	3920-3990 lbs. (1780-1810 kg)
Viggen, Convertible _____	3970 lbs. (1800 kg)
Maximum axle load	
front _____	2300 lbs. (1045 kg)
rear _____	1930 lbs. (875 kg)
Weight distribution:	
Curb weight, front/rear _____	approx. 62/38 %
GVW, front/rear _____	approx. 58/42%

Maximum permitted load in trunk

Coupé and 5-door at curb weight plus
4 passengers à 155 lbs. (70 kg) _____ 130 lbs. (60 kg)

For each passenger less in the rear seat the load may be
increased by 100 lbs. (45 kg)

Convertible at curb weight and
3 passengers à 155 lbs. (70 kg) _____ 120 lbs. (55 kg)

Coupé and 5-door at curb weight and
rear seat right down _____ 475 lbs. (215 kg)



WARNING

- The GVW and maximum axle loads must not be exceeded. Note that if some accessories (e.g. towbar, CD changer) are fitted, the available load capacity is reduced by the weight of these items.
- When goods are being transported their security is important, especially if the car is being used with the rear seat down.

Max. permitted roof load _____ 220 lbs. (100 kg)

Trailer weights:

Trailer with brakes _____ Max. 2000 lbs.
(900 kg)

Trailer without brakes _____ Max. 1000 lbs.
(450 kg)

Recommended towbar-ball load _____ 110-165 lbs.
(50-75 kg)

Maximum towing speed, trailer with
brakes _____ 62 mph (100 km/h)

The above max. weights and speed limit are those which Saab Automobile AB permits. Note that the national rules may set limits to permitted weights and speed; see also page 156.

Engine

Type _____	4 cyl, 2 overhead camshafts, 16 valves and 2 balancer shafts
Cylinder bores _____	3.54" (90 mm)
Stroke:	
2.0 Turbo _____	3.071" (78 mm)
Viggen _____	3.543" (90 mm)
Swept volume:	
2.0 Turbo _____	121 cu.in. (1,985 dm ³)
Viggen _____	140 cu.in. (2,290 dm ³)
Idling speed _____	900 rpm
Antifreeze _____	Saab-approved antifreeze
Coolant volume, cooling system _____	8.7 qts. (8.5 l)

Engine oil
Oil grade:

We recommend the use of oils that are available from your Saab dealer, for the regular oil changes.

These oils fulfill the most stringent requirements set by API and ACEA classifications.

Oil for gasoline engines is classified by the API standards (American Petroleum Institute) into the grade classes SH (since 1993) and SJ (since 1996). The SJ class fulfils more stringent requirements and has a lower phosphorous level.

These grade classes are most often combined with the corresponding classes for diesel engines. The class designations for diesel engines begin with the letter "C" (Commercial). For example a grade combination suitable for both types of engine could be API SH/CD or SJ/CF.

Under ACEA nomenclature, oils are divided into Class A for gasoline engines and Class B for diesel-engined passenger cars. There is a further class for heavy diesel engines. Each class is divided into three grades: 1, 2 and 3, where grades 2 and 3 normally encompass semi and fully-synthetic oils.

In the same way as in the API system, gasoline and diesel engine specifications are combined for products that can be used in both types of engine. For example, a grade designation could be ACEA A2/B2 or ACEA A3/B3.

To afford Saab engines the best protection, with regard to lubrication, the ability to dissolve residues and the neutralization of combustion products, we recommend the following oil grades:

- API SH/CD/CF or SJ/CD/CF.
- ACEA A2/B2 or A3/B3.

These oils contain the additives required for the engine to function well. We advise against the use of further additives.

Viscosity:

The viscosity of oil is classified according to the SAE standard. Nowadays, multigrade oils are always used in cars. The properties of these oils facilitate starting the car in cold weather but mean that the oil is also viscous enough to coat all moving parts under high pressures and with high outside air temperatures. Multigrade oils are graded with two viscosities, e.g. 10W-30, where the 10W meets certain viscosity requirements at -4°F (-20°C), while the 30 fulfills requirements at a temperature of 212°F (100°C).

Basic recommendations for Saab engines:

- **SAE 10W-30 or 10W-40.**

SAE 5W-30 can also be recommended but in which case the oil must be semi of fully-synthetic and fulfil ACEA grade requirements A3/B3.

Oils which are less viscous, such as 0W/-40/50 are becoming more common and may be used. However, the oil must be fully-synthetic, of a well known brand, and fulfil ACEA grade requirements A3/B3.

This viscosity makes starting in cold weather easier.

Oil capacity inc. filter (on changing) _____ 4.0 l

Fuel

Fuel-tank capacity _____ 17 U.S. gal. (64 l)

For optimum performance, we recommend the following:

2.0 Turbo 185 bhp _____ 90 AON, unleaded gasoline, minimum 87 AON

2.0 Turbo 205 bhp and Viggen _____ 93 AON, unleaded gasoline, minimum 87 AON

Engine variants

2.0 Turbo 185 hp, manual transmission

Rating, EEC at 5500 rpm _____ 185 hp (136 kW)
 Max. torque (man.), EEC at 2100 rpm ____ 194.0 ft.lb (263 Nm)
 Compression ratio _____ 9.2:1

2.0 Turbo 185 hp, automatic transmission

Rating, EEC at 5750 rpm _____ 185 hp (136 kW)
 Max. torque EEC at 1900 rpm _____ 184.4 ft.lb. (250 Nm)
 Compression ratio _____ 9.2:1

2.0 Turbo 205 hp, manual transmission

Rating, EEC, at 5500 rpm _____ 205 hp (151 kW)
 Max. torque EEC at 2200 rpm _____ 209 ft.lb (283 Nm)
 Compression ratio _____ 9.2:1

2.0 Turbo 205 hp, automatic transmission

Rating, EEC, at 5750 rpm _____ 205 hp (151 kW)
 Max. torque EEC at 1900 rpm _____ 184.4 ft.lb (250 Nm)
 Compression ratio _____ 9.2:1

2.3 Turbo 230 hp, manual transmission

Rating, EEC, at 5500 rpm _____ 230 hp (169 kW)
 Max. torque EEC at 2500 rpm _____ 258.1 ft.lb (350 Nm)
 Compression ratio _____ 9.3:1

Electrical system

Voltage _____ 12 V
 Battery capacity _____ 60 Ah
 Starter motor _____ 1.4 kW
 Alternator rating _____ 130 A/14 V
 Firing order _____ 1-3-4-2
 Spark plugs:
 2.0 Turbo 185 bhp _____ NGK PFR 7H-10
 2.0 Turbo 205 bhp _____ NGK PFR 7H-10
 Viggen _____ NGK PFR 7H-10
 Electrode gap _____ 1.0 mm

Drive belts

2.0 Turbo and Viggen _____ Outside length
 2345 mm

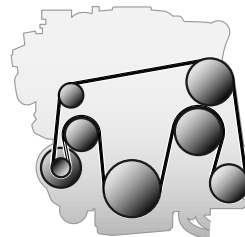

IB923

Drive belt

Manual transmission

Type _____	5-speed, fully synchronized with final-drive gear and differential
Oil type (for topping-up) _____	Saab synthetic manual gearbox oil
Oil capacity _____	1.8 qts. (1.8 l)
Speed (mph/km/h) at 1000 rpm in 5th gear	26/42

Automatic transmission

Type _____	Electronically controlled 4-speed with torque converter and differential
Gear selector positions _____	P R N D 3 2 1
Oil quantity, total _____	7.4 qts. (7.2 litres)
Oil volume (on changing) _____	3.4 qts. (3.25 litres)
Oil type _____	Texaco Texamatic Dexron III, mineral oil based
Clutch type _____	Hydraulically-operated plate clutches, brake bands and one-way clutches
Speed (mph/km/h) at 1000 rpm in 4th gear	25/40

Suspension

Spring type, front and rear _____	Coil springs
Maximum deflection of springs:	
front, Coupé/5-door/Convertible _____	6.4" (163 mm)
front, Viggen _____	6.5" (165 mm)
rear, Coupé/5-door/Convertible _____	8.3" (212 mm)
rear, Viggen _____	7.9" (200 mm)
Dampers, front and rear _____	Gas-filled telescopic shock absorbers

Steering

Steering _____	Power-assisted steering gear of rack-and-pinion type with telescopic, universal joint steering-column shaft
Number of turns, lock to lock _____	3.0
Oil type _____	Power Steering Fluid CHF 11S

Brake system

Footbrake (ABS) _____	Hydraulic disc brakes with vacuum servo, diagonally split circuits
Parking brake _____	Acts on rear wheels
Brake fluid _____	DOT 4 Do not use DOT 5
Disc diameter:	
front, Coupé/5-door/Convertible _____	11.4" (288 mm)
front, Viggen _____	12.0" (306 mm)
rear _____	11.3" (286 mm)
Total friction area of brake pads:	
front, Coupé/5-door/Convertible _____	34.4 in ² (224 cm ²)
front, Viggen _____	35.9 in ² (234 cm ²)
rear _____	14.2 in ² (92 cm ²)

Rims and tires
Rim size:

Coupé/5-door/Convertible _____	6.5 x 15 or 6.5 x 16
Viggen _____	7.5 x 17

Viggen must use 6.5 x 16 or 7 x 17
Tire sizes (summer tires):

6.5 x 15 (not Viggen) _____	195/60 R15
6.5 x 16 _____	205/50 R16
7.5 x 17 Viggen only _____	215/45 R17

Tire sizes (winter tires):

6 x 15 (not Viggen) _____	185/65 R15 M+S 195/60 R15 M+S
6.5 x 16 _____	205/50 R16 M+S

Recommended rims for snow chains:

Coupé/5-door/Convertible _____	6 x 15
Viggen _____	6.5 x 16

Spare wheel:

Tire:	
Coupé/5-door/Convertible _____	T115/70 R15
Viggen _____	T115/70 R16
Rim:	
Coupé/5-door/Convertible _____	4.0 x 15
Viggen _____	4.0 x 16
Maximum life _____	2000 miles (3500 km)
Maximum speed _____	50 mph (80 km/h)

NOTE**Snow chains**

Snow chains must **not** be fitted to the rear wheels and must be used on the following tire/wheel combinations.

Wheel**Tire**

6 x 15 _____ 185/65 R15 M+S (not Vigen),
 195/60 R15 (not Vigen) or
 195/60 R15 M+S (not Vigen)

6.5 x 15 _____ 195/60 R15 (not Vigen)

6.5 x 16 _____ 205/50 R16 or 205/50 R16 M+S

Max. speed is 30 mph (50 km/h).

Consult your authorized Saab dealer of approved snow chains.

NOTE

Coupé/5-door/Convertible: Bigger rims than 16" must not be used. The offset of the rims must not exceed 49 mm.

Vigen: Bigger rims than 17" must not be used. The offset of the rims must not exceed 42 mm.

Front-wheel angles:

Toe-in, measured on the wheel rim _____ 1.5±0.5 mm

Vigen _____ 1.3±0.3 mm

Plates and labels

In contacts with your Saab dealer it may sometimes be necessary to quote the car's chassis, engine and gearbox numbers.

- 1 Modification identity plate (in the spare wheel compartment). On certain model variants, the plate is located on the right-hand door pillar.
- 2 V.I.N. number inside windshield.
- 3 Certification label.
- 4 Gearbox number.
- 5 Engine number.
- 6 Label for tire pressures and color codes (trim and body).
- 7 Chassis number.
- 8 Chassis number (stamped on body).
- 9 Vehicle Emission Control Information.
- 10 Spark ignition system information (Canada only)

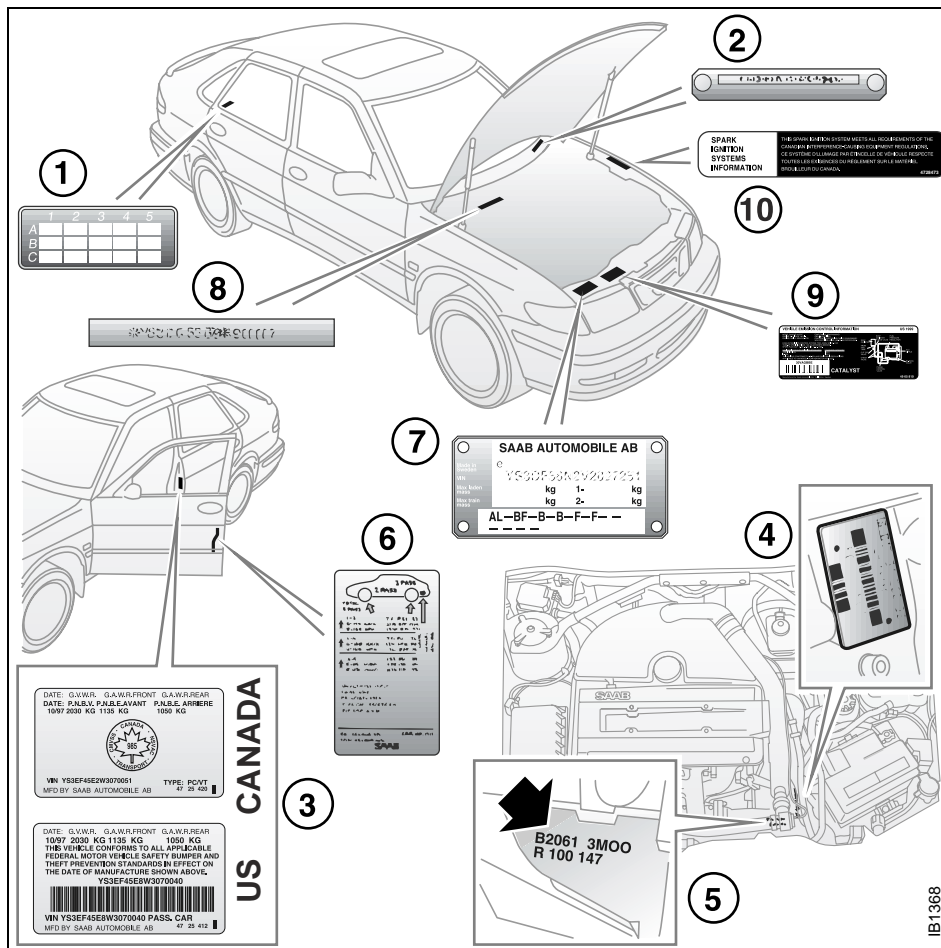

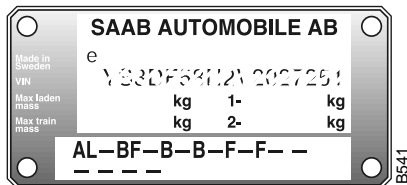

position: 1 2 3 4 5 6 7 8 9 10 11 12
 | | | | | | | | | | | |
 VIN: Y S 3 D F 5 8 K 7 Y 2 005543

| | | | | |

1 2 3 4 5 6 = identification codes for certain chassis details

- | | | | |
|------------------------------|--|--------------------------------|--|
| 1 - Region _____ | Y = Northern Europe | 6 - Body version ____ | 3 = Coupé (3-door)
5 = 5-door
7 = Convertible |
| 2 - Country _____ | S = Sweden | 7 - Gearbox _____ | 5 = Manual 5-speed
8 = Automatic 4-speed |
| 3 - Manufacturer ____ | 3 = Saab Automobile AB | 8 - Engine variant __ | G = 2.3 Turbo Viggen
H = 2.0 Turbo (185 bhp)
K = 2.0 Turbo (205 bhp) |
| 4 - Product line ____ | D = 9-3 | 9 - Check digit _____ | 0-9 or X |
| 5 - Model series ____ | D = 9-3 S with driver's and passenger's airbag
F = 9-3 SE with driver's and passenger's airbag
P = 9-3 Viggen with driver's and passenger's airbag | 10 - Model year _____ | Y = 2000 |
| | | 11 - Factory _____ | 2 = Trollhättan
7 = Nystad |
| | | 12 - Serial number ____ | 000001-999999 |

Several of the systems in your Saab car may be adjusted to better fit your individual needs

Some functions are governed by legal requirements and cannot therefore be reprogrammed.

Consult an authorized Saab dealer for further information.

Car alarm/central locking system:

- The level of the siren when locking/unlocking, HIGH or LOW.
- The number of blinks when locking/unlocking, 1 to 7.
- Automatic locking of the trunk when the car is driven, 1 to 8 mph (2-14 km/h), YES or NO.
- Preclude the unlocking of the trunk while the car is driven, YES or NO.
- Automatic locking of the trunk after 1 second-4 minutes if it has not been opened, YES or NO.
- Automatic locking of the trunk when it is closed, YES or NO.

Automatic climate control (ACC):

- Indoor temperature can be increased/decreased relative to the selected temperature.
- Delayed start of fan after starting the car, to reduce risk of fogging windshield.
- Temperature at which the defroster mode is automatically selected.
- Response time for the fan speed when the selected temperature is changed.
- Temperature at which the air distribution switches from defrost mode to defrost/floor mode.
- Last manual selection will be selected the next time the car is started.

Saab Information Display (SID):

- Outdoor temperature display can be adjusted.
- Days remaining to next service can be activated/counted or not.
- Delete "Test Brake Light" message on SID at start-up.

Miscellaneous:

- Select the on-time for heated rear seat.
- Coolant temperature gauge adjustment can be increased/decreased.
- Fuel level gauge adjustment can be increased/decreased.
- Additional sweep of the wipers after windshield washer function (ON or OFF).
- Follow me home on-time can vary from 20 to 50 seconds.
- Night panel illumination deactivation speed for the speedometer can be adjusted.

Following adjustments can be done by the driver:

Automatic Climate Control (ACC):

To alter the preprogrammed "AUTO" start up mode with your own preferences you can manually select the desired settings for:

- Temperature.
- Fan speed.
- Air distribution.

See "Programming I" on page 86 and "Programming II" on page 87.

Saab 9-3 Audio System:

The following functions can be adjusted by the driver (see page 104):

- Maximum starting volume (when the radio is switched on).
- Telephone volume (if the car is equipped with a phone connected to the audio system).
- Speed dependent volume (volume increases or decreases with vehicle speed).
- Loudness.

Alarm System:

The glass breakage sensor can be temporarily disabled, see page 36.

Daytime Running Lights:

To disable, turn off the ignition and pull out fuse 15, see page 189.

Index

A

A/C system, fault diagnosis _____	207
A/C system, maintenance _____	207
ACC _____	80
ACC, useful tips _____	88
Adjustment, steering wheel _____	118
Air conditioning (A/C), fault diagnosis and maintenance ____	207
Airbag _____	22
Alarm _____	35
Alarm functions _____	38
Alarm signals _____	38
Anticorrosion treatment _____	203
Anti-theft safety, alarm _____	35
Ashtray _____	123
Audio System _____	90
Automatic climate control (ACC) _____	80
Automatic transmission _____	141

B

Battery _____	177
Boost starting from donor battery ____	162
Brake fluid, check _____	176
Brake fluid, grade _____	227
Brake pad wear indicators _____	176
Brakes _____	149

Braking _____	149
Bulb table _____	186

C

CD changer _____	101
CD player _____	99
CHECK messages _____	63, 68
CHECKING _____	63, 68
Cabin lighting _____	121
Calibration, ACC _____	86
Car alarm _____	35
Car phone, installation _____	109
Cassette player _____	96
Center console compartment _____	123
Central locking _____	30
Change of address notification ____	214
Changing a wheel _____	196
Changing bulbs _____	181
Changing the coolant _____	175
Changing the engine oil _____	173
Changing wiper blades _____	179
Chassis number _____	229
Child car seats _____	18
Child safety _____	18
Child safety locks, rear doors _____	33
Child seats _____	18
Cigar lighter _____	123
Cleaning the soft top _____	51
Climate-control system, manual ____	76
Clock _____	69

Condensation water, A/C _____	78
Condensation water, ACC _____	81
Convertible _____	42
Coolant _____	174
Courtesy Headlight Feature _____	72
Cruise Control _____	148
Cup holder _____	122

D

DICE/TWICE _____	188
Date code, tires _____	195
Dim low beam _____	71
Dimmer _____	74
Direction indicators _____	72
Direction-indicator stalk _____	72
Dome lighting _____	121
Door mirrors _____	124
Drive belt _____	179
Driving in deep water _____	166
Driving in hot weather _____	156
Driving technique _____	153
Driving with a compact spare wheel _	165
Driving with a roof load _____	158
Driving with the trunk lid open _____	166

E

Economical motoring _____	153
Electrical system, technical data ____	225

Manual climate-control system _____	76
Manual raising of the soft top, Convertible _____	46
Manually opening the fuel filler door, Convertible _____	52
Manually opening the fuel filler door, Coupé and 5-door _____	131
Maxi fuses _____	188
Memory, driver's seat _____	117
Motoring abroad _____	165

N

Night Panel _____	69
-------------------	----

O

Odometer _____	59
Oil specification _____	223
OnStar _____	109
Opening handle _____	30
Owner assistance _____	213

P

Paint touch-up _____	202
Parcel shelf _____	128
Parking _____	151
Parking brake _____	151

Parking lights _____	71
Plates and labels _____	229
Power-steering fluid, check _____	177
Pressure gauge _____	60
Programmable driver's seat _____	117
Programming, ACC _____	86

R

Radio _____	94
Raising the soft top, Convertible _____	45
Rear fog light _____	73
Rear seat _____	125
Rear seat, tipping _____	125
Rear window wiper _____	75
Rearview mirrors _____	124
Rear-window wiper _____	75
Recirculation _____	78
Recycling _____	205
Refuelling _____	138
Relay table _____	190
Remote control _____	30
Remote control battery, changing _____	32
Reporting safety defects _____	214
Rev counter _____	59
Reversing lights _____	73
Rotating the tires _____	193
Running-in _____	140

S

SAHR, head restraint _____	114
SID (Side instrument display) _____	62
SRS (airbag) _____	22
Safety belts _____	12
Safety belts, care of _____	199
Seat-belt pretensioners _____	13
Seats _____	112
Securing a load _____	33
Service costs _____	213
Service information _____	214
Service intervals _____	212
Service record retention _____	213
Side airbag _____	27
Side airbags _____	27
Ski hatch _____	128
Snow tires _____	227
Soft-top storage, Convertible _____	50
Spare wheel _____	130
Speedometer _____	59
Starting the engine _____	135
Steering pump oil, grade _____	226
Steering-wheel adjustment _____	118
Sunroof _____	120

T

Tachometer _____	59
Tailgate, opening _____	33
Technical data _____	220

Temperature gauge _____	60
Textile carpeting, cleaning _____	200
Through-load hatch _____	128
Tie-down eyes _____	129
Tipping the rear seat _____	125
Tire pressures _____	192
Tires and wheels, sizes _____	227
Tools _____	130
Touching up paintwork _____	202
Towing a caravan or trailer _____	156
Towing the car _____	160
Trailer hitch load _____	158
Transmission, automatic _____	141
Transporting the car _____	160
Traveling abroad _____	165
Trionic _____	170
Trip computer, SID _____	62
Trip meter _____	59
Trunk _____	125
Trunk lid lock, Convertible _____	50
Trunk, Convertible _____	50
Turbo gauge _____	60
Turn signal _____	72

U

Upholstery and trim _____	200
Upholstery and trim, care of _____	200
Useful tips on starting _____	136
Useful tips, ACC _____	88

V

Vanity mirror _____	124
---------------------	-----

W

Warning labels _____	7
Warning light, AIR BAG (SRS) _____	24
Washer fluid _____	179
Washer jets _____	180
Washers _____	74
Washing _____	201
Waxing and polishing _____	202
Wear indicators, brake pads _____	140
Wear indicators, tires _____	195
Wheels _____	192
Wheels and tires, sizes _____	227
Window glass sensor, car alarm _____	36
Windshield washers _____	74
Windshield wipers _____	74
Winter driving _____	154
Wiper blades _____	179
Wipers _____	74