



Operator's Manual  
C-Class



2 0 4 5 8 4 1 1 8 1

Order No. 6515 0614 13 Part No. 204 584 11 81 USA Edition A 2008

C-Class



Mercedes-Benz

C 230 (Canada only)  
C 230 Sport (Canada only)  
C 230 4MATIC (Canada only)  
C 230 4MATIC Sport (Canada only)  
C 300  
C 300 Sport  
C 300 4MATIC  
C 300 4MATIC Sport  
C 350 (Canada only)  
C 350 Sport  
C 350 4MATIC (Canada only)  
C 350 4MATIC Sport (Canada only)

Our company and staff congratulate you on the purchase of your new Mercedes-Benz.

Your selection of our product is a demonstration of your trust in our company name. Furthermore, it exemplifies your desire to own an automobile that will be as easy as possible to operate and provide years of service.

Your Mercedes-Benz represents the efforts of many skilled engineers and craftsmen. To help assure your driving pleasure, and also the safety of you and your passengers, we ask you to make a small investment of time:

- Please read this manual carefully, then return it to your vehicle where it will be handy for your reference.
- Please follow the recommendations contained in this manual. They are designed to acquaint you with the operation of your Mercedes-Benz.
- Please pay attention to the warnings and cautions contained in this manual. They are designed to help improve the safety of the vehicle operator and occupants.

We extend our best wishes for many miles of safe, pleasurable driving.

Mercedes-Benz USA, LLC  
A DaimlerChrysler Company

<b>Introduction</b> .....	9
Product information.....	9
Operator's Manual.....	10
Service and warranty information ..	10
Important notice for California retail buyers and lessees of Mercedes-Benz automobiles .....	11
Maintenance .....	11
Roadside Assistance .....	12
Change of address or ownership....	12
Operating your vehicle outside the USA or Canada .....	12
Where to find it.....	13
Symbols.....	14
Operating safety .....	15
Proper use of the vehicle .....	15
Problems with your vehicle.....	16
Reporting safety defects.....	17
Reporting safety defects .....	17
Vehicle data recording.....	18
Information regarding electronic recording devices.....	18

<b>At a glance</b> .....	19
Exterior view.....	20
Storage compartments.....	22
Cockpit.....	24
Instrument cluster .....	26
Multifunction steering wheel .....	28
Center console .....	29
Upper part .....	29
Lower part .....	30
Overhead control panel .....	31
Driver's door control panel and seat adjustment/memory* .....	32

<b>Safety and Security</b> .....	33
Occupant safety .....	34
Air bags .....	36
Occupant Classification System .....	41
Seat belts .....	46
Active head restraints.....	50
Children in the vehicle .....	51
Blocking of rear door window operation.....	57
Panic alarm .....	58
Driving safety systems .....	59
ABS.....	59
Adaptive Brake .....	60
BAS.....	60
EBP .....	61
ESP® .....	62
Four wheel electronic traction system (4MATIC) with the ESP® .....	65
Anti-theft systems .....	66
Immobilizer .....	66
Anti-theft alarm system .....	66
Canceling the alarm.....	67

# Contents

<b>Controls in detail</b> .....	69	Steering wheel.....	93	Lighting .....	108
Locking and unlocking .....	70	Steering wheel adjustment,		Exterior lamp switch .....	108
SmartKey .....	70	manual .....	93	Switching on high beams .....	112
SmartKey with KEYLESS-GO*		Steering wheel adjustment,		Headlamp cleaning system* .....	112
(Canada only) .....	73	electrical* (Canada only).....	94	Corner-illuminating front	
Checking batteries in the SmartKey		Easy-entry/exit feature*		fog lamps* (With Bi-Xenon*	
or SmartKey with KEYLESS-GO*		(Canada only) .....	95	headlamps only).....	112
(Canada only) .....	78	Mirrors.....	97	Hazard warning flasher .....	114
Loss of the SmartKey or SmartKey		Interior rear view mirror .....	97	Interior lighting .....	114
with KEYLESS-GO* (Canada only) ..	79	Exterior rear view mirrors.....	97	Door entry lamps .....	116
Opening doors from the inside .....	79	Power folding		Trunk lamp.....	116
Automatic central locking .....	80	exterior rear view mirrors* .....	98	Windshield wipers .....	117
Locking and unlocking		Interior rear view mirror,		Switching on/off	
from the inside .....	81	antiglare position .....	99	windshield wipers .....	118
Starter switch positions.....	82	Auto-dimming rear view mirrors* .	100	Single wipe .....	118
SmartKey .....	82	Activating exterior rear view mirror		Intermittent wiping .....	118
SmartKey with KEYLESS-GO*		parking position* (Canada only)...	101	Wiping with	
(Canada only) .....	83	Memory function* (Canada only).....	102	windshield washer fluid.....	119
Seats.....	85	Storing positions into memory* ...	103	Power windows .....	120
Seat adjustment.....	85	Recalling positions from memory*	103	Opening and closing	
Lumbar support.....	91	Storing exterior rear		power windows .....	120
Seat heating* .....	91	view mirror parking position* .....	104	Summer opening feature .....	123
		Fastening the seat belts .....	105	Convenience closing feature.....	124
		Proper use of seat belts .....	106		
		Seat belt height adjustment.....	107		

Driving and parking.....	126	Tachometer.....	149	“911” emergency call .....	231
Starting the engine.....	126	Outside temperature indicator.....	149	Phone book.....	233
Driving off .....	129	Fuel gauge .....	150	Call lists.....	236
Turn signals.....	131	Control system .....	151	Making calls.....	237
Problems while driving .....	132	Multifunction display.....	151	Functions during a single call .....	240
Parking.....	133	Multifunction steering wheel.....	152	Driving systems.....	241
Turning off the engine .....	134	Menus.....	154	Cruise control .....	241
Releasing seat belts .....	135	Trip menu.....	156	Hill start assist system .....	246
Manual transmission .....	136	Navi* menu.....	158	Air vents .....	247
Shifting into reverse.....	137	Audio menu.....	158	Opening and closing air vents.....	248
Automatic transmission* .....	138	TEL menu* .....	160	Dual-zone automatic climate control..	250
Gear selector lever.....	138	Service menu .....	164	Deactivating the	
Shifting procedure .....	139	Settings menu.....	165	climate control system .....	252
Gear selector lever positions .....	140	Audio system.....	176	Operating the climate control	
Driving tips.....	142	Audio and telephone, operation....	176	system in automatic mode .....	253
Gear ranges .....	143	Audio system overview .....	176	Setting the temperature .....	253
Automatic shift program .....	144	Operating safety .....	177	Adjusting air distribution .....	254
Gear selector lever		Audio system components.....	177	Adjusting air volume .....	254
one-touch gearshifting .....	145	Menu.....	185	Using driver-side settings for all	
Emergency operation		Operation.....	188	temperature zones (Canada only) .	254
(Limp-Home Mode) .....	146	SYS menu .....	192	Front defroster .....	255
Instrument cluster .....	147	Radio operation .....	194	Maximum cooling MAX COOL	
Multifunction display.....	147	Satellite radio* .....	200	(USA only).....	256
Adjusting instrument		CD mode.....	208	Rear window defroster.....	256
cluster display illumination.....	148	Audio Aux mode.....	220	Air recirculation mode .....	257
Coolant temperature gauge .....	148	Telephone* .....	222	Air conditioning .....	258

# Contents

3-zone automatic climate control* (Canada only).....	259	Synchronizing.....	275	<b>Operation</b> .....	309
Deactivating		Panorama roof with		The first 1000 miles (1500 km) .....	310
climate control system.....	261	power tilt/sliding panel* .....	276	Driving instructions .....	311
Operating climate control		Roller sunblinds.....	276	Drive sensibly – save fuel.....	311
system in automatic mode .....	261	Opening and closing panorama		Drinking and driving.....	311
Setting the temperature .....	262	roof with power tilt/sliding panel.	277	Pedals .....	311
Adjusting air distribution .....	263	Synchronizing.....	278	Power assistance .....	311
Adjusting air volume.....	263	Loading and storing .....	280	Brakes.....	312
Using driver-side settings for		Roof rack* .....	280	Driving off .....	314
all temperature zones.....	263	Split rear bench seat* .....	281	Parking.....	314
Front defroster .....	264	Loading instructions.....	282	Tires.....	315
Rear window defroster .....	265	Storage compartments .....	283	Hydroplaning.....	315
Air recirculation mode .....	265	Cup holders.....	287	Tire traction .....	316
Residual engine heat		Trunk.....	288	Tire speed rating .....	316
and ventilation.....	266	Useful features .....	289	Winter driving instructions .....	317
Air conditioning.....	267	Sun visors .....	289	Standing water.....	318
Rear climate control .....	268	Rear window sunshade* .....	290	Passenger compartment.....	318
Trunk .....	269	Ashtrays.....	291	Driving abroad .....	318
Opening trunk .....	269	Cigarette lighter .....	292	Control and operation	
Closing trunk.....	270	Power outlet in the glove box.....	293	of radio transmitters .....	319
Trunk emergency release .....	271	Power outlet in the		Catalytic converter.....	319
Valet locking .....	272	rear passenger compartment.....	293	Emission control .....	320
Power tilt/sliding sunroof .....	273	Floor mats* .....	294	Coolant temperature.....	321
Opening and closing		ITele Aid* .....	295		
power tilt/sliding sunroof.....	273	Garage door opener* .....	303		







## ▼ Product information

Please observe the following in your own best interest:

We recommend using Genuine Mercedes-Benz Parts as well as conversion parts and accessories explicitly approved by us for your vehicle model.

We have tested these parts to determine their reliability, safety and special suitability for Mercedes-Benz vehicles.

We are unable to make an assessment for other products and therefore cannot be held responsible for them, even if in individual cases an official approval or authorization by governmental or other agencies should exist. Use of such parts and accessories could adversely affect the safety, performance or reliability of your vehicle. Please do not use them.

Genuine Mercedes-Benz parts, as well as approved conversion parts and accessories are available at your authorized Mercedes-Benz Center. Here they can be properly installed and you will receive comprehensive information, including advice on permissible technical modifications.

### Operator's Manual

This Operator's Manual contains a great deal of useful information. We urge you to read it carefully and familiarize yourself with the vehicle before driving.

For your own safety and longer service life of the vehicle, we urge you to follow the instructions and warnings contained in this manual. Ignoring them could result in damage to the vehicle or personal injury to you or others. Vehicle damage caused by failure to follow instructions is not covered by the Mercedes-Benz Limited Warranty.

Your vehicle may have some or all of the equipment described in this manual. Therefore, you may find explanations for optional equipment not installed in your vehicle. If you have any questions about the operation of any equipment, your authorized Mercedes-Benz Center will be glad to demonstrate the proper procedures.

We continuously strive to improve our product, and ask for your understanding that we reserve the right to make changes in design and equipment. Therefore, information, illustrations and descriptions in this Operator's Manual might differ from your vehicle.

Optional equipment is also described in this manual, including operating instructions wherever necessary. Since they are special-order items, the descriptions and illustrations herein may vary slightly from the actual equipment of your vehicle.

If there are any equipment details that are not shown or described in this Operator's Manual, your authorized Mercedes-Benz Center will be glad to inform you of correct care and operating procedures. The Operator's Manual and Maintenance Booklet are important documents and should be kept with the vehicle.

### Service and warranty information

The Service and Warranty Information Booklet contains detailed information about the warranties covering your Mercedes-Benz, including:

- New Vehicle Limited Warranty
- Emission System Warranty
- Emission Performance Warranty
- California, Maine, Massachusetts, and Vermont Emission Control System Warranty (California, Maine, Massachusetts, and Vermont only)
- State Warranty Enforcement Laws (Lemon Laws)

### **Important notice for California retail buyers and lessees of Mercedes-Benz automobiles**

---

Under California law you may be entitled to a replacement of your vehicle or a refund of the purchase price or lease price, if Mercedes-Benz USA, LLC and/or its authorized repair or service facilities fail to fix one or more substantial defects or malfunctions in the vehicle that are covered by its express warranty after a reasonable number of repair attempts. During the period of 18 months from original delivery of the vehicle or the accumulation of 18 000 miles (approximately 29 000 km) on the odometer of the vehicle, whichever occurs first, a reasonable number of repair attempts is presumed for a retail buyer or lessee if one or more of the following occurs:

- (1) the same substantial defect or malfunction results in a condition that is likely to cause death or serious bodily injury if the vehicle is driven, that defect or malfunction has been subject to repair two or more times, and you have directly notified Mercedes-Benz USA, LLC in writing of the need for its repair,
- (2) the same substantial defect or malfunction of a less serious nature than category (1) has been subject to repair four or more times and you have directly notified us in writing of the need for its repair, or
- (3) the vehicle is out of service by reason of repair of the same or different substantial defects or malfunctions for a cumulative total of more than 30 calendar days.

Written notification should not be sent to a dealer, it should be addressed to:

Mercedes-Benz USA, LLC  
Customer Assistance Center  
One Mercedes Drive  
Montvale, NJ 07645-0350

### **Maintenance**

---

The Maintenance Booklet describes all the necessary maintenance work which should be performed at regular intervals.

Always have the Maintenance Booklet with you when you take the vehicle to your authorized Mercedes-Benz Center for service. The service advisor will record each service in the booklet for you.

### Roadside Assistance

---

The Mercedes-Benz Roadside Assistance Program provides factory trained technical help in the event of a breakdown. Calls to the toll-free Roadside Assistance number

**1-800-FOR-MERCEdes (in the USA)**  
**1-800-387-0100 (in Canada)**

will be answered by Mercedes-Benz Customer Assistance Representatives 24 hours a day, 365 days a year.

For additional information refer to the Mercedes-Benz Roadside Assistance Program brochure in your vehicle literature portfolio.

### Change of address or ownership

---

If you change your address, be sure to send in the "Change of Address Notice" found in the Service and Warranty Information Booklet, or simply call the Mercedes-Benz Customer Assistance Center (in the USA) at 1-800-FOR-MERCEdes, or Customer

Service (in Canada) at 1-800-387-0100. It is in your own interest that we can contact you should the need arise.

If you sell your Mercedes, please leave all literature with the vehicle to make it available to the next operator.

If you bought this vehicle used, be sure to send in the "Notice of Purchase of Used Car" found in the Service and Warranty Information Booklet, or call the Mercedes-Benz Customer Assistance Center (in the USA) at 1-800-FOR-MERCEdes, or Customer Service (in Canada) at 1-800-387-0100.

### Operating your vehicle outside the USA or Canada

---

If you plan to operate your vehicle in foreign countries, please be aware that:

- service facilities or replacement parts may not be readily available,

- unleaded gasoline for vehicles with catalytic converters may not be available; the use of leaded fuels will damage the catalysts,
- gasoline may have a considerably lower octane rating, and improper fuel can cause engine damage.

Certain Mercedes-Benz models are available for delivery in Europe under our European Delivery Program. For details, consult your authorized Mercedes-Benz Center or write to:

In the USA:

Mercedes-Benz USA, LLC  
European Delivery Department  
One Mercedes Drive  
Montvale, NJ 07645-0350

In Canada:

Mercedes-Benz Canada, Inc.  
European Delivery Department  
98 Vanderhoof Avenue  
Toronto, Ontario M4G 4C9

## ▼ Where to find it

This Operator's Manual is designed to provide comprehensive support information for you, the vehicle operator. Each section has its own reference color.

### At a glance

Here you will find an overview of your vehicle's interior and exterior main features.

### Safety and Security

Here you will find descriptions of the safety and security features of your vehicle.

### Controls in detail

Here you will find detailed information about the equipment installed in your vehicle. This section also describes technical innovations.

### Operation

Here you will find all the information you need for the proper operation of your vehicle.

### Practical hints

This section provides fast assistance for dealing with problems you may encounter.

### Technical data

All important technical data for your vehicle can be found in this section.

### Indexes

The table of contents and the index are designed to help you find information quickly and easily.

The following publications are part of your vehicle documentation:

- this Operator's Manual
- the Maintenance Booklet

Separate operating instructions will be provided as required depending on the equipment options installed in your vehicle.

## Symbols

Trademarks:

- ESP® is a registered trademark of DaimlerChrysler.
- HomeLink® is a registered trademark of Prince, a Johnson Controls Company.
- SIRIUS and related marks are trademarks of SIRIUS Satellite Radio Inc.

The following symbols are found in this Operator's Manual:

- \* Optional equipment is identified with an asterisk. Since standard equipment varies between models, the descriptions and illustrations in this manual may differ slightly from the actual equipment of your vehicle.

### Warning!



Warning notices draw your attention to hazards that may endanger your health or life, or the health or life of others.

 *Highlights hazards that may result in damage to your vehicle.*

 *Helpful hints or further information you may find useful.*

- ▶ This symbol points to instructions for you to follow.
- ▶ A number of these symbols appearing in succession indicates a multiple-step procedure.
- ▷ page This symbol tells you where to look for further information on a topic.
- ▷▷ This continuation symbol marks a warning which is continued on the next page.
- ▷▷ This continuation symbol marks a procedure which is continued on the next page.
- > This symbol is used to indicate cross-references to term definitions.
- Display Words appearing in the multi-function display and COMAND display are printed in the type shown here.

## ▼ Operating safety

### Warning!



Work improperly carried out on electronic components and associated software could cause them to cease functioning. Because the vehicle's electronic components are interconnected, any modifications made may produce an undesired effect on other systems. Electronic malfunctions could seriously impair the operating safety of your vehicle.

See an authorized Mercedes-Benz Center for repairs or modifications to electronic components.

Other improper work or modifications on the vehicle could also have a negative impact on the operating safety of the vehicle.

Some safety systems only function while the engine is running. You should therefore never turn off the engine while driving.

### Warning!



Heavy blows against the vehicle underbody or tires/wheels, for example when running over an obstacle, road debris or a pothole, may cause serious damage and impair the operating safety of your vehicle. If you feel a sudden significant vibration or ride disturbance, or you suspect that damage to your vehicle has occurred, you should turn on your hazard warning flashers, carefully slow down, and drive with caution to an area which is a safe distance from the road.

Inspect the vehicle underbody and tires/wheels for possible damage. If the vehicle appears unsafe, have it towed to the nearest authorized Mercedes-Benz Center or other qualified maintenance or repair facility for further inspection or repairs.

## Proper use of the vehicle

Proper use of the vehicle requires that you are familiar with the following information and rules:

- the safety precautions in this manual
- the “Technical data” section in this manual
- traffic rules and regulations
- motor vehicle laws and safety standards

### Warning!



Various warning labels are attached to your vehicle. These warning labels are intended to make you and others aware of various risks. You should not remove any of these warning labels unless explicitly instructed to do so by information on the label itself. Removal of any of these labels may cause you and others to be unaware of certain risks which may result in an accident and/or personal injury.



### Problems with your vehicle

If you should experience a problem with your vehicle, particularly one that you believe may affect its safe operation, we urge you to immediately contact an authorized Mercedes-Benz Center to have the problem diagnosed and corrected if required. If the matter is not handled to your satisfaction, please discuss the problem with the Mercedes-Benz Center management, or if necessary contact us at one of the following addresses:

In the USA:

Customer Assistance Center  
Mercedes-Benz USA, LLC  
One Mercedes Drive  
Montvale, NJ 07645-0350

In Canada:

Customer Relations Department  
Mercedes-Benz Canada, Inc.  
98 Vanderhoof Avenue  
Toronto, Ontario, M4G 4C9

## ▼ Reporting safety defects

For the USA only:

The following text is published as required of manufacturers under Title 49, Code of U.S. Federal Regulations, Part 575 pursuant to the “National Traffic and Motor Vehicle Safety Act of 1966.”

### **Reporting safety defects**

---

If you believe that your vehicle has a defect which could cause a crash or could cause injury or death, you should immediately inform the National Highway Traffic Safety Administration (NHTSA) in addition to notifying Mercedes-Benz USA, LLC.

If NHTSA receives similar complaints, it may open an investigation, and if it finds that a safety defect exists in a group of vehicles, it may order a recall and remedy campaign. However, NHTSA cannot become involved in individual problems between you, your dealer, or Mercedes-Benz USA, LLC.

To contact NHTSA, you may call the Vehicle Safety Hotline toll-free at 1-888-327-4236 (TTY: 1-800-424-9153); go to <http://www.safercar.gov>; or write to: Administrator, NHTSA, 400 Seventh Street, SW., Washington, DC 20590. You can also obtain other information about motor vehicle safety from <http://www.safercar.gov>.

### Vehicle data recording

#### Information regarding electronic recording devices

---

(Including notice pursuant to California Code § 9951)

Please note that your vehicle is equipped with devices that can record vehicle systems data and, if equipped with the Tele Aid\* system, may transmit some data in certain accidents.

This information helps, for example, to diagnose vehicle systems after a collision and to continuously improve vehicle safety. DaimlerChrysler may access the information and share it with others

- for safety research or vehicle diagnosis purposes
- with the consent of the vehicle owner or lessee
- in response to an official request by law enforcement or other government agency
- for use in dispute resolution involving DaimlerChrysler, its affiliates or sales/service organization and/or
- as otherwise required or permitted by law.

Please check the Tele Aid\* subscription service agreement for details regarding the information that may be recorded or transmitted via that system.

**Exterior view**

**Storage compartments**

**Cockpit**

**Instrument cluster**

**Multifunction steering wheel**

**Center console**

**Overhead control panel**

**Driver's door control panel and seat  
adjustment/memory\***



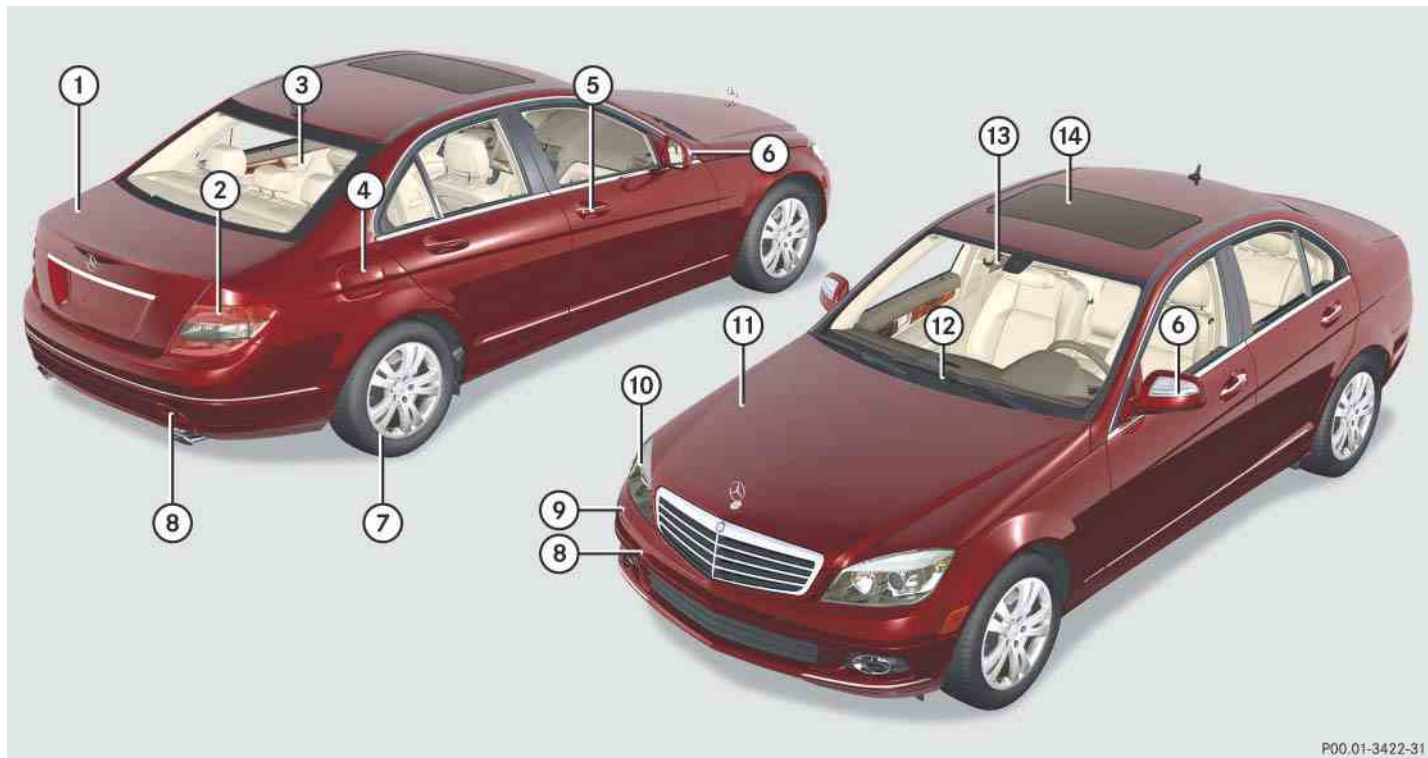

P00.01-3422-31

Item	Page
① Trunk	
• Unlocking	269
• Opening and closing	269
• Minispare wheel	441
• Vehicle tool kit	420
② Rear lamps	431
③ Rear window, defrosting	265
④ Fuel filler flap	322
Refueling	322
Gasoline	481
⑤ Doors	
• Locking and unlocking	70
• Opening and closing	70
• Unlocking/locking in an emergency	424
⑥ Exterior rear view mirror	
• Adjusting	97

Item	Page
• Auto-dimming rear view mirrors*	97
• Power folding exterior rear view mirrors*	100
• Parking position* (Canada only)	98
	101
⑦ Tires and wheels	331
• Checking tire inflation pressure	341
• Tire Pressure Monitoring System (TPMS), (USA only)	344
• Run Flat Indicator (Canada only)	342
• General information	331
• Minispare wheel	422
• Flat tire	440
⑧ Towing the vehicle	453
Installing towing eye bolt	455

Item	Page
⑨ Headlamp cleaning system*	112
⑩ Front lamps	431
⑪ Hood, opening	325
Engine oil	327
Coolant	329
Battery	446
⑫ Windshield wipers	117
Wiper blades, replacing	438
Wiper blades, cleaning	368
⑬ Windshield	
Front window, defrosting	264
Cleaning with wiper fluid	119
Cleaning	368
⑭ Roofs	
• Power tilt/sliding sunroof	273
• Panorama roof with power tilt/sliding panel*	276

Storage compartments

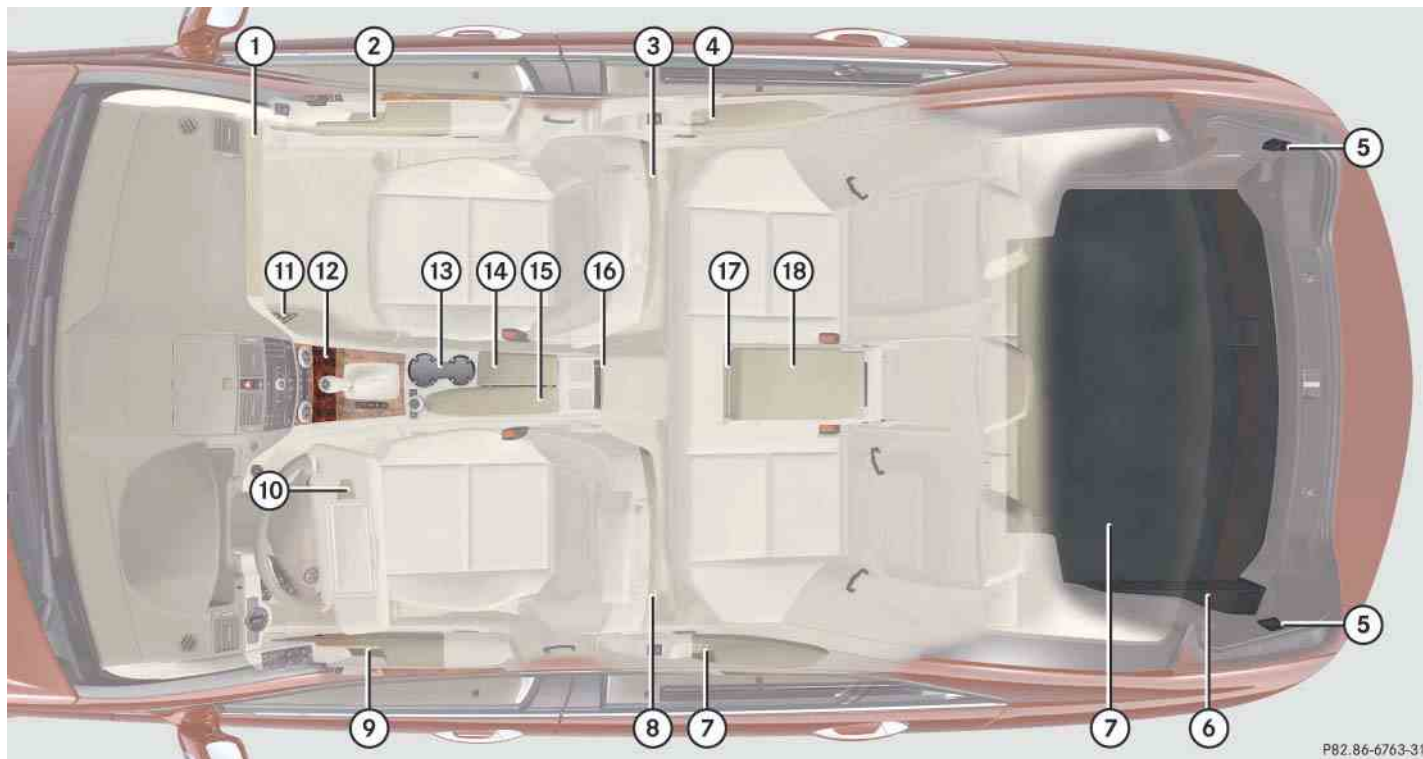

## Storage compartments

	Item	Page
①	Glove box	284
	Power outlet	293
	Aux socket	220
②	Door pocket	
③	Storage pocket	286
④	Door pocket	
⑤	Hooks on left and right side in trunk	288
⑥	Parcel net on left side in trunk	288
⑦	Storage space for Minispare wheel and vehicle tool kit in trunk	422, 420
⑧	Door pocket	

	Item	Page
⑨	Storage pocket	286
⑩	Door pocket	
⑪	Document holder in sun visor	289
⑫	Parcel net in front passenger footwell	285
⑬	Ashtray	291
	Cigarette lighter	292
⑭	Cup holder	287
⑮	Right storage compartment in front center armrest	284

	Item	Page
⑯	Right storage compartment in front center armrest	284
⑰	Ashtray in rear passenger compartment	292
	Power outlet	293
⑱	Cup holder in the rear center armrest	287
⑲	Rear center armrest with storage compartment and cup holder	286
		287





Item	Page
① Lever for cruise control	242
② Instrument cluster	26
③ Multifunction steering wheel	152
④ Horn	
⑤ Overhead control panel	31
⑥ Glove box	284
⑦ Glove box lock	284
⑧ Center console	29
⑨ Starter switch	82
KEYLESS-GO* start/stop button (Canada only)	83





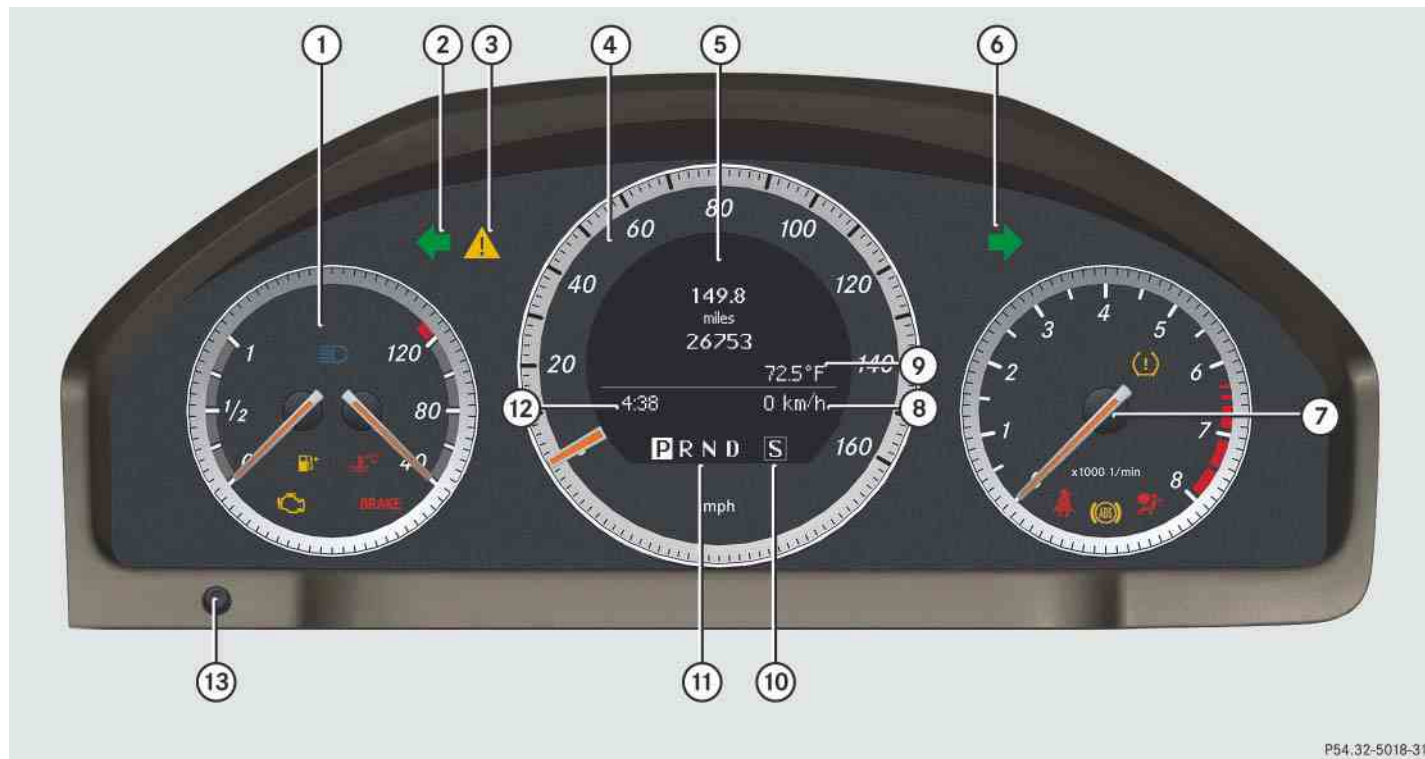

Item	Page
⑩ Steering wheel release handle (manual)	94
⑪ Steering wheel adjustment stalk (electrical)* (Canada only)	93
⑫ <b>Combination switch</b>	
• High beam	112
• Corner-illuminating lamps*	112
• Windshield wipers	117
• Turn signals	131







Item	Page
⑬ Hood lock release	326
⑭ Parking brake pedal	130
⑮ Parking brake release	130
⑯ Exterior lamp switch	108
⑰ Door control panel and seat adjustment/memory*	32

Instrument cluster



P54.32-5018-31

Item	Page
① <b>Combination gauge with:</b>	
Fuel gauge	
 Fuel tank reserve warning lamp	380
Coolant temperature gauge	112
 Coolant temperature warning lamp	374
Indicator/warning lamps:	382
 High beam headlamp indicator lamp	378
 Engine malfunction indicator lamp	
 Brake warning lamp	376
USA only	
 Canada only	
②  Left turn signal indicator lamp	131

Item	Page
③  Electronic Stability Program (ESP®) warning lamp	380
④ Speedometer	
⑤ Multifunction display	
⑥  Right turn signal indicator lamp	131
⑦ <b>Tachometer with:</b>	
 Combination low tire pressure/TPMS malfunction telltale, USA only	380
 SRS indicator lamp	382
 Antilock Brake System (ABS) indicator lamp	59
 Seat belt telltale	380
⑧ Outside temperature (manual transmission)	149
Outside temperature / additional speedometer (automatic transmission*)	149, 169

Item	Page
⑨ Outside temperature (automatic transmission*)	149, 169
⑩ Selected program mode indicator (automatic transmission*)	140
⑪ Gear position/range indicator (automatic transmission*)	143
Additional speedometer (manual transmission)	169
⑫ Digital clock	151
⑬ Instrument cluster illumination	148

## Multifunction steering wheel

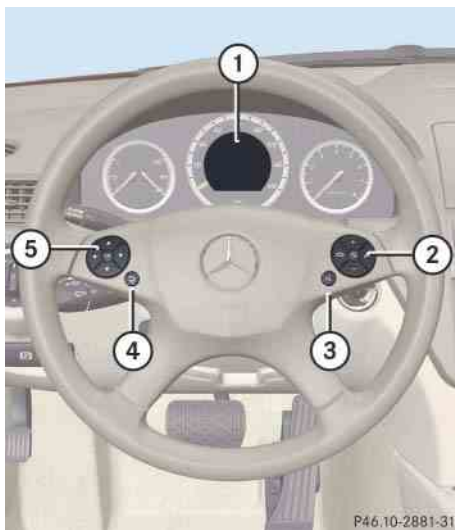

	Item	Page
①	Multifunction display	151
	<b>Operating control system</b>	151
②	Volume control: Press button	
	to increase volume	
	to decrease volume	
	Telephone*: Press button	
	to take a call to dial a call	
	to end a call to reject an incoming call	
	to mute	
③	to activate Voice Control* <sup>1</sup>	

	Item	Page
④	to cancel Voice Control* <sup>1</sup> , back, to confirm message	152
⑤	To call up line for menus and select menus: Press button	
	to scroll to the right	
	to scroll to the left	
	To select submenu or scroll through lists: Press button	
	to scroll up	
	to scroll down	
	Press button	
	to confirm selection	

<sup>1</sup> Voice Control\* is only available with COMAND\*. Refer to separate operating instructions.

## ▼ Center console

## Upper part



P68.20-3727-31

Item	Page
① Audio display cover	180
② Hazard warning flasher switch - switching on/off	114
③ Anti-theft alarm system indicator lamp	66
④ Front passenger front air bag off indicator lamp	45, 385, 393
⑤ ESP® control switch	64
⑥ Audio system, or COMAND* (see separate operating instructions)	176

Item	Page
⑦ Seat heating*, passenger side	91
⑧ Rear window sunshade switch*	290
⑨ Dual-zone automatic climate control	250
3-zone automatic climate control* (Canada only)	259
Rear window defroster	256, 265
⑩ Seat heating*, driver's side	91

## Center console

### Lower part

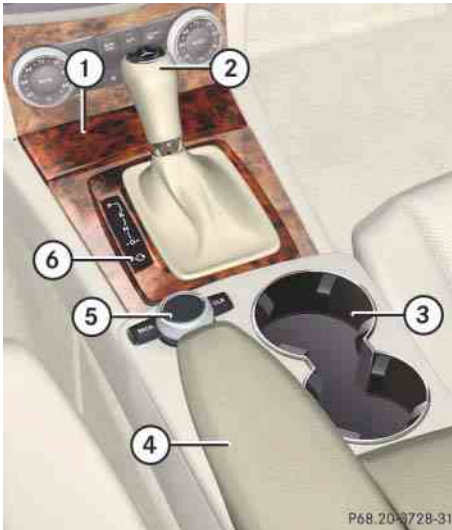

	Item	Page
①	Ashtray	291
	Cigarette lighter	292
②	Gearshift lever for manual transmission	138
	Gear selector lever for automatic transmission*	140
③	Cup holder	287
④	Split storage compartment, left and right side of the center armrest	284
⑤	Audio controller COMAND-controller* (see separate operating instructions)	182
⑥	Program mode selector switch for automatic transmission*	144

## ▼ Overhead control panel



Item	Page
① Rear interior lighting on/off	116
② Interior lighting control	115
③ Right reading lamp on/off	115
④ Power tilt/sliding sunroof or Panorama roof with power tilt/sliding panel*	273  276
⑤ Information button*	300
⑥ Tele Aid* (emergency call system) button	295

Item	Page
⑦ Rear view mirror	97
⑧ Garage door opener*	303
⑨ Hands-free microphone for <ul style="list-style-type: none"> <li>• Tele Aid* (emergency call system)</li> <li>• Telephone*</li> <li>• Voice Control*<sup>1</sup></li> </ul>	295  160
⑩ Roadside Assistance button*	299
⑪ Left reading lamp on/off	115
⑫ Front interior lighting on/off	114

<sup>1</sup> Voice Control\* is only available with COMAND\*. Refer to separate operating instructions.



## Driver's door control panel and seat adjustment/memory\*



Item	Page
① Inside door handle	79
② Central unlocking switch	81
③ Seat adjustment (at side of the respective front seat)	85
Seat adjustment* (Canada only)	85
④ Memory function* for storing seat, exterior mirror, and steering wheel settings (Canada only)	102
⑤ Exterior rear view mirrors adjustment	97
⑥ Switches for opening/ closing side windows	120
⑦ Rear door window override switch	57
⑧ Remote trunk opening switch	269
⑨ Central locking switch	81

**Occupant safety**

**Panic alarm**

**Driving safety systems**

**Anti-theft systems**



## Occupant safety

In this section you will learn the most important facts about the restraint systems of the vehicle.

The restraint systems are

- Seat belts
- Child restraints
- Lower Anchors and Tethers for Children (LATCH)

Additional protection potential provide

- Supplemental Restraint System (SRS) with
  - Air bags
  - Air bag control unit (with crash sensors)
  - Emergency Tensioning Device (ETD) for seat belts
  - Seat belt force limiter
- Active head restraints

Air bag system components with

- Front passenger front air bag off indicator lamp
- Front passenger seat with Occupant Classification System (OCS)

Although independent systems, their protective functions work in conjunction with each other.

 For information on infants and children traveling with you in the vehicle and restraint systems for infants and children, see “Children in the vehicle” (▷ page 51).

The SRS system conducts a self-test when the ignition is switched on and in regular intervals while the engine is running. This facilitates early detection of malfunctions. The  indicator lamp in the instrument cluster (▷ page 26) comes on when the ignition is switched on and goes out no later than a few seconds after the engine has been started.

The SRS components are in operational readiness when the  indicator lamp is not lit when the engine is running.

A malfunction in the system has been detected if the  indicator lamp:

- fails to go out after approximately 4 seconds after the engine was started
- does not come on at all
- comes on after the engine was started or while driving

**Warning!**

Modifications to or work improperly conducted on restraint systems (such as seat belts and anchors, Emergency Tensioning Devices (ETDs), seat belt force limiters or air bags) or their wiring, as well as tampering with interconnected electronic systems, can lead to the restraint systems no longer functioning as intended.

Air bags or Emergency Tensioning Devices (ETDs), for example, could deploy inadvertently or fail to deploy in accidents although the deceleration threshold for air bag deployment is exceeded. Therefore, never modify the restraint systems. Do not tamper with electronic components or their software.

**Warning!**

In the event that the  indicator lamp comes on during driving or does not come on at all, the SRS self-check has detected a malfunction. For your safety, we strongly recommend that you contact an authorized Mercedes-Benz Center immediately to have the system checked; otherwise the SRS may not deploy when needed in an accident, which could result in serious or fatal injury, or it might deploy unexpectedly and unnecessarily which could also result in injury.

In addition, improper work on the SRS creates a risk of rendering the SRS inoperative or causing unintended air bag deployment. Work on the SRS must therefore only be performed by qualified technicians. Contact an authorized Mercedes-Benz Center.

If it is necessary to modify an air bag system to accommodate a person with disabilities, contact your local authorized Mercedes-Benz Center or call our Customer Assistance Center at 1-800-FOR-MERCEdes (1-800-367-6372) for details.

## Occupant safety

### Air bags

#### Warning!



Air bags are designed to reduce the potential of injury and fatality in certain frontal impacts (front air bags), side impacts (front side impact air bags, rear side impact air bags\* and window curtain air bags) or rollovers (window curtain air bags). However, no system available today can totally eliminate injuries and fatalities.

The deployment of the air bags temporarily releases a small amount of dust from the air bags. This dust, however, is neither injurious to your health, nor does it indicate a fire in the vehicle. The dust might cause some temporary breathing difficulty for people with asthma or other breathing trouble. To avoid this, you may wish to get out of the vehicle as soon as it is safe to do so. If you have any breathing difficulty but cannot get out of the vehicle after the air bag inflates, then get fresh air by opening a window or door.

#### Warning!



To reduce the risk of injury when the front air bags inflate, it is very important for the driver and front passenger to always be in a properly seated position and to wear their respective seat belt.

For maximum protection in the event of a collision always be in normal seated position with your back against the backrest. Fasten your seat belt and make sure it is properly positioned on your body.

Since the air bag inflates with considerable speed and force, a proper seating and hands on steering wheel position will help to keep you at a safe distance from the air bag. Occupants who are unbelted, out of position or too close to the air bag can be seriously injured or killed by an air bag as it inflates with great force in the blink of an eye:

- Sit properly belted in a nearly upright position with your back against the seat backrest.

- Adjust the driver's seat as far as possible rearward, still permitting proper operation of vehicle controls. The distance from the center of the driver's breastbone to the center of the air bag cover on the steering wheel must be at least 10 inches (25 cm) or more. You should be able to accomplish this by a combination of adjustments to the seat and steering wheel. If you have any problems, please see an authorized Mercedes-Benz Center.
- Do not lean your head or chest close to the steering wheel or dashboard.
- Keep hands on the outside of steering wheel rim. Placing hands and arms inside the rim can increase the risk and potential severity of hand/arm injury when driver's front air bag inflates.
- Adjust the front passenger seat as far as possible rearward from the dashboard when the seat is occupied.

- Always sit as upright as possible, properly use the seat belts and use an appropriately sized infant restraint, toddler restraint, or booster seat recommended for the size and weight of the child.

Failure to follow these instructions can result in severe injuries to you or other occupants.

If you sell your vehicle, it is important that you make the buyer aware of this safety information. Be sure to give the buyer this Operator's Manual.

### Warning!



Accident research shows that the safest place for children in an automobile is in the rear seat.

There is a possibility for a side impact air bag related injury if occupants, especially children, are not properly seated or restrained when next to a front side impact air bag and/or rear side impact air bag\* which

needs to deploy rapidly in a side impact in order to do its job.

To help avoid the possibility of injury, please follow these guidelines:

- (1) Always sit as upright as possible, properly use the seat belts, and for all children 12 years old and under, use an appropriately sized infant restraint, toddler restraint, or booster seat recommended for the size and weight of the child.
- (2) Always wear seat belts properly.

**i** *Air bags are designed to deploy only in certain frontal impacts (front air bags), and in side impacts (front side impact air bags, rear side impact\* air bags, and window curtain air bags) which exceed preset thresholds, and in certain rollovers (window curtain air bags). Only during these events will they provide their supplemental protection.*

*The driver and passengers should always wear their seat belts. Otherwise it is not possible for air bags to provide their supplemental protection.*

*In case of other types of impacts and impacts below air bag deployment thresholds, air bags will not deploy. The driver and passenger will then be protected to the extent possible by a properly fastened seat belt. A properly fastened seat belt is also needed to provide the best possible protection in a rollover.*

*We caution you not to rely on the presence of the air bags in order to avoid wearing your seat belt.*

*It is important to your safety and that of your passengers that you replace deployed air bags and repair any malfunctioning air bags to make sure the vehicle will continue to provide supplemental crash protection for occupants.*

## Occupant safety

### Safety guidelines for the seat belt, emergency tensioning device and air bag

#### Warning!



- Damaged seat belts or seat belt that were highly stressed in an accident must be replaced and their anchoring points must also be checked. Only use seat belts installed or supplied at an authorized Mercedes-Benz Center.
- Air bags and Emergency Tensioning Devices (ETDs) contain Perchlorate material, which may require special handling and regard for the environment. Check with your local government's disposal guidelines. California residents, see <http://www.dtsc.ca.gov/HazardousWaste/Perchlorate/index.cfm>.
- Air bags and pyrotechnic emergency tensioning devices (ETDs) are designed to function on a one-time-only basis. An air bag or ETD that is deployed must be replaced.

- Do not pass seat belt over sharp edges. They could tear.
- Do not make any modification that could change the effectiveness of the seat belts.
- Do not bleach or dye seat belts as this may severely weaken them. In a crash they may not be able to provide adequate protection.
- No modifications of any kind may be made to any components or wiring of the SRS. This includes changing or removing any component or part of the SRS, the installation of additional trim material, badges, etc. over the steering wheel hub, front passenger front air bag cover, outboard sides of the seat backrests, door trim panels, or door frame trims, and installation of additional electrical/electronic equipment on or near SRS components and wiring. Keep area between air bags and occupants free from objects (e.g. packages, purses, umbrellas, etc.).
- Do not hang items such as coat hangers from the coat hooks or handles over the door. These items may turn into projectiles and cause head and other injuries when the window curtain air bag is deployed.
- Air bag system components will be hot after an air bag has inflated. Do not touch.
- Never place your feet on the instrument panel, dashboard, or on the seat. Always keep both feet on the floor in front of the seat.
- In addition, improper repair work on the SRS creates a risk of rendering the SRS inoperative or causing unintended air bag deployment. Work on the SRS must therefore only be performed by qualified technicians. Contact an authorized Mercedes-Benz Center.

- For your protection and the protection of others, when scrapping the air bag unit or emergency tensioning device, our safety instructions must be followed. These instructions are available from your authorized Mercedes-Benz Center.
- Given the considerable deployment speed, required inflation volume, and the textile structure of the air bags, there is the possibility of abrasions or other, potentially more serious injuries resulting from air bag deployment.

### Warning!



Only use seat covers which have been tested and approved by Mercedes-Benz for your vehicle model. Using other seat covers may interfere with or prevent the deployment of the front side impact air bags or the rear side impact air bags. Contact an authorized Mercedes-Benz Center for availability.

When you sell your vehicle we strongly urge you to give notice to the subsequent owner that it is equipped with an SRS by alerting them to the applicable section in the Operator's Manual.

### Front air bags



- ① Driver air bag
- ② Front passenger front air bag

The front air bags are designed to provide increased protection for the driver and front passenger against the risk of injuries to the head and thorax.

Driver and front passenger front air bag are deployed:

- in the event of certain frontal impacts
- if impact exceeds a preset deployment threshold
- if the system determines that airbag deployment can offer additional protection to that provided by the seat belt
- depending on whether the seat belt is in use
- independently of the front side impact air bags, rear side impact air bags\* and/or the window curtain air bags.

**i** The front air bags in this vehicle have been designed to inflate in two stages. This allows the air bag to have different rates of inflation that are based on the rate of relevant vehicle deceleration as assessed by the air bag control unit.

On the front passenger-side, the front air bag deployment is additionally influenced by the passenger's weight category as identified by the Occupant Classification System (OCS) (▷ page 41).

The lighter the front passenger-side occupant, the higher the vehicle deceleration rate required for the second stage inflation of the air bag.





## Occupant safety

The front air bags will not deploy in impacts which do not exceed the system's deployment thresholds. You will then be protected by the fastened seat belts.

The front airbags are not deployed in the event of a rollover unless the vehicle's rate of longitudinal deceleration or acceleration exceeds the preset deployment threshold for the front air bags.

The front passenger front air bag ② (▷ page 39) will only be deployed if:

- the system, based on OCS weight sensor readings, senses that the front passenger seat is occupied
- the   indicator lamp in the center console is not lit (▷ page 45)
- the impact exceeds a preset deployment threshold

### Front side impact air bags and rear side impact air bags\*



- ① Front side impact air bag
- ② Rear side impact air bag\*

When deployed, the front side impact air bags ① and/or the rear side impact air bags\* ② are designed to provide increased protection for the thorax (but not the head, neck and arms) of the occupants on the side of the vehicle on which the impact occurs.

The front side impact air bags ① and the rear side impact air bags\* ② are deployed:

- on the impacted side of the vehicle
- in impacts exceeding a preset deployment threshold
- independently of the front air bags

The front passenger front side impact air bag ① will not deploy if the OCS senses that the front passenger seat is empty and the front passenger seat belt is not fastened (latch plate is not inserted into the buckle). With an empty front passenger seat and the seat belt fastened (latch plate properly inserted into buckle) the front passenger side impact air bag ① will deploy regardless of the empty seat.

The front side impact air bags ① and the rear side impact air bags\* ② are not deployed in impacts which do not exceed the system's deployment threshold.

### Window curtain air bags

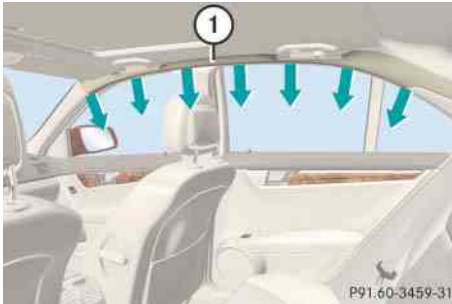

#### ① Window curtain air bag

When deployed, the window curtain air bags ① are designed to provide increased protection for the head (but not the chest or arms) of the occupants on the side of the vehicle on which the impact occurs.

The window curtain air bags fill up the area indicated by the arrows.

The window curtain air bags are deployed:

- on the impacted side of the vehicle
- in impacts exceeding a preset deployment threshold
- independently of the front air bags
- regardless of whether the front-passenger seat is occupied
- in certain vehicle rollovers

The side window curtain air bags are not deployed in impacts which do not exceed the system's deployment threshold.

### Occupant Classification System

The Occupant Classification System (OCS) automatically turns the front passenger front air bag on or off based on the classified occupant weight category determined by weight sensor readings from the front passenger seat.

**i** *The system does not deactivate the front passenger side impact air bag, the window curtain air bag and the emergency tensioning device.*

Occupants must sit properly belted in a position that is as upright as possible with their back against the seat backrest and feet on the floor to be correctly classified. If the occupant's weight is transferred to another object in the vehicle (e.g. by leaning on armrests), the OCS may not be able to properly approximate the occupant's weight category.

## Occupant safety



**i** If your seat, including your trim cover and cushion needs to be serviced in any way, take the vehicle to an authorized Mercedes-Benz Center.

Only seat accessories approved by Mercedes-Benz may be used.

Both driver and the front passenger should always use the  indicator lamp as an indication of whether or not the front passenger is properly positioned.

### Warning!







If the  indicator lamp illuminates when an adult or someone larger than a small individual is in the front passenger seat, have the front passenger re-position himself or herself in the seat until the  indicator lamp goes out, or check whether objects are caught under or around the seat.

In the event of a collision, the air bag control unit will not allow front passenger front air bag deployment when the OCS classified the front passenger seat occupant as being up to or less than the weight of a typical 12-month-old child in a standard child restraint or if the front passenger seat is sensed as being empty.

When the OCS senses that the front passenger seat occupant is classified as being up to or less than the weight of a typical 12-month-old child in a standard child restraint, the  indicator lamp will illuminate when the engine is started and

remain illuminated, indicating that the front passenger front air bag is deactivated.

When the OCS senses that the front passenger seat is classified as being empty, the  indicator lamp will illuminate when the engine is started and remain illuminated, indicating that the front passenger front air bag is deactivated.

When the OCS senses that the front passenger seat occupant is classified as being heavier than the weight of a typical 12-month-old child seated in a standard child restraint or as being a small individual (such as a young teenager or a small adult), the  indicator lamp will illuminate for approximately 6 seconds when the engine is started and then, depending on occupant weight sensor readings from the seat, remain illuminated or go out. With the  indicator lamp illuminated, the front passenger front air bag is deactivated. With the  indicator lamp out, the front passenger front air bag is activated.

When the OCS senses that the front passenger seat occupant is classified as an adult or someone larger than a small individual, the



indicator lamp will illuminate for approximately 6 seconds when the engine is started and then go out, indicating that the front passenger front air bag is activated.

If the  indicator lamp is illuminated, the front passenger front air bag is deactivated and will not be deployed.

If the  indicator lamp is not illuminated, the front passenger front air bag is activated and will be deployed:

- in the event of certain frontal impacts
- if impact exceeds a preset deployment threshold
- independently of the front side impact air bags and/or rear side impact air bags\*.

If the front passenger front air bag is deployed, the rate of inflation will be influenced by:

- the rate of relevant vehicle deceleration as assessed by the air bag control unit

- front passenger's weight category as identified by the Occupant Classification System (OCS).

More information about air bag display messages (▷ page 393).

### Warning!



According to accident statistics, children are safer when properly restrained in the rear seating positions than in the front seating position. Thus, we strongly recommend that children be placed in the rear seats whenever possible. Regardless of seating position, children 12 years old and under must be seated and properly secured in an appropriate infant or child restraint recommended for the size and weight of the child.





The infant or child restraint must be properly secured with the vehicle's seat belt, the seat belt and top tether strap, or lower anchors and top tether strap, fully in accordance with the child seat manufacturer's instructions.

Children can be killed or seriously injured by an inflating air bag. Note the following important information when circumstances require you to place a child in the front passenger seat:

- Your vehicle is equipped with air bag technology designed to turn off the front passenger front air bag in your vehicle when the system senses the weight of a typical 12-month-old child or less along with the weight of a standard appropriate child restraint on the front passenger seat.
- A child in a rear-facing child restraint on the front passenger seat will be seriously injured or even killed if the front passenger front air bag inflates in a collision which could occur under some circumstances, even with the air bag technology installed in your vehicle. The only means to completely eliminate this risk is to never place a child in a rear-facing child restraint in the front seat. We therefore strongly recommend that you always place a child in a rear-facing child restraint in the back seat. ▷▷

## Occupant safety



- If you must install a rear-facing child restraint on the front passenger seat because circumstances require you to do so, make sure the  indicator lamp is illuminated, indicating that the front passenger front air bag is deactivated. Should the  indicator lamp not illuminate or go out while the restraint is installed, please check installation. Periodically check the  indicator lamp while driving to make sure the  indicator lamp is illuminated.

If the  indicator lamp goes out or remains out, do not transport a child on the front passenger seat until the system has been repaired. A child in a rear-facing child restraint on the front passenger seat will be seriously injured or even killed if the front passenger front air bag inflates.

- If you have to place a child in a forward-facing child restraint on the front passenger seat, move the seat as far back as possible, use the proper child restraint recommended for the age, size and weight of the child, and secure child restraint with the vehicle's seat belt according to the child seat manufacturer's instructions. For children larger than the typical 12-month-old child, the front passenger front air bag may or may not be activated.

 *Deployment of the driver front air bag does not mean that the front passenger front air bag also should have deployed.*

*The Occupant Classification System (▷ page 41) may have determined:*

- *that the seat was empty or occupied by the weight up to or less than that of a typical 12-month-old child seated in a standard child restraint – both instances where the system suppresses deployment of the front passenger front air bag even though the impact met the criteria and was of sufficient severity to deploy the driver front air bag.*
- *that the seat was occupied by a small individual (such as a young teenager or a small adult) or a child weighing more than the weight of a typical 12-month-old child in a standard child restraint – instances where the system may suppress deployment of the front passenger front air bag even though the impact met the criteria and was of sufficient severity to deploy the driver front air bag.*





### ① Front passenger front air bag off indicator lamp

The  indicator lamp ① will be illuminated, except with the SmartKey removed from the starter switch or with the starter switch in position 0.

### Warning!



If the  indicator lamp and the  indicator lamp are lit at the same time, there is a malfunction in the Occupant Classification System. The front passenger front air bag will be deactivated in this case.



Have the system checked as soon as possible by qualified technicians. Contact an authorized Mercedes-Benz Center.

Only have the seat repaired or replaced at an authorized Mercedes-Benz Center.

In order to ensure proper operation of the air bag system and OCS:

- Sit properly belted in a position that is as upright as possible with your back against the seat backrest.
- While seated, an occupant should not position him/herself in such a way as to cause the occupant's weight to be lifted from the seat bottom as this may result in the OCS being unable to correctly approximate the occupant's weight category.
- Read and observe all warnings in this chapter.

### Self-test Occupant Classification System

After turning the SmartKey in the starter switch to position 1 or 2 or pressing the KEYLESS-GO\* start/stop button (Canada only) once or twice, the  indicator lamp ① illuminates. If an adult occupant is properly sitting on the front passenger seat and the system senses the occupant as being an adult, the  indicator lamp will illuminate and go out after approximately 6 seconds.

If the seat is not occupied and the system senses the front passenger seat as being empty, the  indicator lamp will illuminate and not go out.

### Warning!



If the  indicator lamp should not illuminate, the system is not functioning. You must see an authorized Mercedes-Benz Center before seating any child on the front passenger seat.

### Occupant safety

For more information, see the “Practical hints” section (▷ page 385).

#### Warning!



Never place anything between seat cushion and child seat (e.g. pillow), since it reduces the effectiveness of the Occupant Classification System. The bottom of the child seat must make full contact with the passenger seat cushion. An incorrectly mounted child seat could cause injuries to the child in case of an accident, instead of increasing protection for the child.

Follow the manufacturer’s instructions for installation of child seats.

### Seat belts

The use of seat belts and infant and child restraint systems is required by law in all 50 states, the District of Columbia, the U.S. territories and all Canadian provinces.

Even where this is not the case, all vehicle occupants should have their seat belts fastened whenever the vehicle is in motion.

For more information, see “Fastening the seat belts” (▷ page 105).

**i** *For information on infants and children traveling with you in the vehicle and restraint systems for infants and children, see “Children in the vehicle” (▷ page 51).*

#### Warning!



Always fasten your seat belt before driving off. Always make sure all of your passengers are properly restrained.

Failure to wear and properly fasten and position your seat belt greatly increases your risk of injuries and their likely severity in an accident. You and your passengers should always wear seat belts.

If you are ever in an accident, your injuries can be considerably more severe without your seat belt properly buckled.

Without your seat belt buckled, you are much more likely to hit the interior of the vehicle or be ejected from it. You can be seriously injured or killed.

In the same crash, the possibility of injury or death is lessened if you are properly wearing your seat belt. Air bags can only protect as they are designed for, if the occupants are properly wearing their seat belts.

**Warning!**

Never ride in a moving vehicle with the seat backrest in an excessively reclined position as this can be dangerous. You could slide under the seat belt in a collision. If you slide under it, the seat belt would apply force at the abdomen or neck. That could cause serious or even fatal injuries. The seat backrest and seat belt provide the best restraint when the wearer is in a nearly upright position and the seat belt is properly positioned on the body.

**Warning!**

Never let more people ride in the vehicle than there are seat belts available. Make sure everyone riding in the vehicle is correctly restrained with a separate seat belt. Never use a seat belt for more than one person at a time.

**Warning!**

Damaged seat belts or seat belts that were highly stressed in an accident must be replaced and their anchoring points must also be checked.

Only use seat belts which have been approved by Mercedes-Benz.

Do not make any modifications to the seat belts. This can lead to unintended activation of the ETDs or to failure.

Do not bleach or dye seat belts as this may severely weaken them. In a crash they may not be able to provide adequate protection.

Have all work carried out only by qualified technicians. Contact an authorized Mercedes-Benz Center.

**Warning!****USE SEAT BELTS PROPERLY**

- Seat belts can only work when used properly. Never wear seat belts in any other way than as described in this section, as that could result in serious injuries in case of an accident.
- Each occupant should wear their seat belt at all times, because seat belts help reduce the likelihood of and potential severity of injuries in accidents, including rollovers. The integrated restraint system includes SRS (driver air bag, passenger front air bag, front side impact air bags, rear side impact air bags\*, window curtain air bags for side windows), ETD (seat belt emergency tensioning device with seat belt force limiters), and front seat knee bolsters. The system is designed to enhance the protection offered to properly belted occupants in certain frontal (front air bags and ETD) and side (front side impact air bags, rear side impact air bags\*, window curtain air bags and ETD)





## Occupant safety



impacts which exceed preset deployment thresholds and in certain rollovers (window curtain air bags and ETD).

- Never wear the shoulder belt under your arm, against your neck or off your shoulder. In a frontal crash, your body would move too far forward. That would increase the chance of head and neck injuries. The seat belt would also apply too much force to the ribs or abdomen, which could severely injure internal organs such as your liver or spleen.
- Never wear seat belts over rigid or breakable objects in or on your clothing, such as eyeglasses, pens, keys, etc., as these might cause injuries.
- Position the lap belt as low as possible on your hips and not across the abdomen. If the seat belt is positioned across your abdomen, it could cause serious injuries in a crash.
- Never use a seat belt for more than one person at time. Do not fasten a seat belt around a person and another person or other objects.



- Seat belts should not be worn twisted. In a crash, you wouldn't have the full width of the seat belt to distribute impact forces. The twisted seat belt against your body could cause injuries.
- Pregnant women should also always use a lap-shoulder belt. The lap belt portion should be positioned as low as possible on the hips to avoid any possible pressure on the abdomen.
- Never place your feet on the instrument panel, dashboard or on the seat. Always keep both feet on the floor in front of the seat.
- When using a seat belt to secure infant restraint, toddler restraint, or booster seat, always follow the child seat manufacturer's instructions.

### Enhanced seat belt reminder system

When the engine is started, the seat belt telltale  will always illuminate for 6 seconds to remind you and your passengers to fasten your seat belts.

If the driver's seat belt is not fastened when the engine is started, an additional warning chime will also sound for a maximum of 6 seconds or until the driver's seat belt is fastened.

If after these 6 seconds the driver's or the front passenger's seat belt (with the front passenger seat occupied) is not fastened with front doors closed,

- the seat belt telltale  remains illuminated for as long as either the driver's or front passenger's seat belt is not fastened.
- and if the vehicle speed once exceeds 15 mph (25 km/h), the seat belt telltale  starts flashing and a warning chime sounds with increasing

intensity for a maximum of 60 seconds or until the driver's and the front passenger's seat belt are fastened.

If you and/or your front passenger release the seat belt during driving, the seat belt telltale  starts flashing and a warning chime sounds as described before.

If the driver's or the front passenger's seat belt remains unfastened after 60 seconds, the warning chime stops sounding, the seat belt telltale  stops flashing but continues to be illuminated.

After a vehicle standstill, the warning chime reactivates and the seat belt telltale  flashes again when the vehicle speed exceeds 15 mph (25 km/h).

The seat belt telltale  will only go out if both the driver's and the front passenger's seat belt (with the front passenger seat occupied) are fastened, or the vehicle is standing still and a front door is opened.

For more information, see "Practical hints" (▷ page 380).

### Emergency tensioning device (ETD), seat belt force limiter

The seat belts are equipped with Emergency Tensioning Devices (ETDs) and seat belt force limiters.

The ETD is designed to activate in the following cases:

- in frontal or rear-end impacts exceeding the system deployment threshold
- in certain vehicle rollovers
- if the restraint systems are operational and functioning correctly, see  indicator lamp (▷ page 382)

 *The ETDs for the front seats will only activate if the front seat belt is fastened (latch plate properly inserted into buckle).*

*The ETDs for the rear seats will activate with or without the respective seat belt fastened.*

In an impact, the ETDs remove slack from the seat belts in such a way that the seat belts fit more snugly against the body. Seat belt force limiters, when activated, are employed to help reduce the peak force exerted by the seat belts on occupants during a crash.

 *ETDs do not correct an incorrect seat position or incorrectly worn seat belts.*

*ETDs do not pull occupants back toward the backrest.*

### Warning!



A pyrotechnic Emergency Tensioning Device (ETD) that was activated must be replaced.

When disposing of the pyrotechnic Emergency Tensioning Device (ETD), our safety instructions must be followed. These are available at an authorized Mercedes-Benz Center.

## Occupant safety

### Active head restraints

The active head restraints are intended to offer the driver and front passenger increased protection from whiplash type injuries. In the event of a rear-end collision, the active head restraints on the driver's and front passenger's seats are designed to move forward in the direction of travel, providing the head with increased support earlier on in the collision sequence. The active head restraints move forward whether the seat is occupied or not.

#### Warning!



Do not attach any objects (e.g. hangers) to the head restraint posts. Otherwise, the active head restraints may not function properly or offer the degree of protection they were designed for in the event of an accident.

If the active head restraints have been triggered in an accident, the active head restraints must be reset. Otherwise, the active head restraints cannot offer any additional protection in the event of another rear-end collision.

For information on resetting the activated active head restraints, see "Resetting activated head restraints" (▷ page 427).

You cannot remove the active head restraint on the driver's and front passenger's seats.  
For removal contact an authorized Mercedes-Benz Center.

#### Warning!



Only use seat or head restraint covers which have been tested and approved by Mercedes-Benz for your vehicle model. Using other seat or head restraint covers may interfere with or prevent the activation of the active head restraints. Contact an authorized Mercedes-Benz Center for availability.

#### Warning!



For your protection, drive only with properly positioned head restraints.

Adjust head restraint so that it is as close to the head as possible and the center of the head restraint supports the back of the head at eye level. This will reduce the potential for injury to the head and neck in the event of an accident or similar situation.

For information on head restraint adjustment, see "Adjusting rear head restraints" (▷ page 89).

## Children in the vehicle

If an infant or child is traveling with you in the vehicle:

- ▶ Secure the child using an infant or child restraint appropriate to the age and size of the child.
- ▶ Make sure the infant or child is properly secured at all times while the vehicle is in motion.

### Warning!



Do not leave children unattended in the vehicle, even if they are secured in a child restraint system. The children could

- injure themselves on parts of the vehicle
- be seriously or fatally injured through excessive exposure to extreme heat or cold

Do not expose the child restraint system to direct sunlight. The child restraint system's metal parts, for example, could become very hot, and the child could be burned on these parts.

If children open a door, they could

- injure other persons
- get out of the car and injure themselves or be injured by following traffic

Unsecured or improperly positioned cargo increases a child's risk of injury in the event of

- strong braking maneuvers
- sudden changes of direction
- an accident

## Infant and child restraint systems

We recommend all infants and children be properly restrained at all times while the vehicle is in motion.

All lap-shoulder belts except the driver's seat belt have special seat belt retractors for secure fastening of child restraints.

To fasten a child restraint, follow child restraint instructions for mounting. Then pull the shoulder belt out completely and let it retract. During seat belt retraction, a ratcheting sound can be heard to indicate that the special seat belt retractor is activated. The seat belt is now locked. Push down on child restraint to take up any slack.

To deactivate, release seat belt buckle and let seat belt retract completely. To deactivate the special seat belt retractor for the front passenger seat, the front passenger seat must be in the most backward position. The seat belt can again be used in the usual manner.

### Occupant safety

#### Warning!



Never release the seat belt buckle while the vehicle is in motion, since the special seat belt retractor will be deactivated.

**i** *Information on child seats with mounting fittings for tether anchorages (▷ page 54).*

*For information on LATCH-type child seat mounts (▷ page 55).*

The use of infant or child restraints is required by law in all 50 states, the District of Columbia, the U.S. territories and all Canadian provinces.

Infants and small children should be seated in an appropriate infant or child restraint system properly secured in accordance with the manufacturer's instructions for the child restraint, that complies with U.S. Federal Motor Vehicle Safety Standards 213 and 225 and Canadian Motor Vehicle Safety Standards 213 and 210.2.

A statement by the child restraint manufacturer of compliance with these standards can be found on the instruction label on the restraint and in the instruction manual provided with the restraint.

When using any infant or child restraint system, make sure to carefully read and follow all manufacturer's instructions for installation and use.

Please read and observe warning labels affixed to the inside of the vehicle and to infant or child restraints.

#### Warning!





According to accident statistics, children are safer when properly restrained in the rear seating positions than in the front seating position. Thus, we strongly recommend that children be placed in the rear seats whenever possible. Regardless of seating position, children 12 years old and under must be seated and properly secured in an appropriately sized infant restraint, toddler restraint, or booster seat recommended for the size and weight of the child.



The infant or child restraint must be properly secured with the vehicle's seat belt, the seat belt and top tether strap, or lower anchors and top tether strap, fully in accordance with the child seat manufacturer's instructions.

Occupants, especially children, should always sit as upright as possible, properly use the seat belts and use an appropriately sized infant restraint, toddler restraint, or booster seat recommended for the size and weight of the child.

Children can be killed or seriously injured by an inflating air bag. Note the following important information when circumstances require you to place a child in the front passenger seat:

- Your vehicle is equipped with air bag technology designed to turn off the front passenger front air bag in your vehicle when the OCS senses the weight of a typical 12-month-old child or less along with the weight of a standard appropriate child restraint on the front passenger seat.

- A child in a rear-facing child restraint on the front passenger seat will be seriously injured or even killed if the front passenger front air bag inflates in a collision which could occur under some circumstances, even with the air bag technology installed in your vehicle. The only means to completely eliminate this risk is to never place a child in a rear-facing child restraint in the front seat. We therefore strongly recommend that you always place a child in a rear-facing child restraint in the back seat.
- If you must install a rear-facing child restraint on the front passenger seat because circumstances require you to do so, make sure the  indicator lamp is illuminated, indicating that the front passenger front air bag is deactivated. Should the  indicator lamp not illuminate or go out while the restraint is installed, please check installation.

Periodically check the  indicator lamp while driving to make sure the  indicator lamp is illuminated. If the  indicator lamp goes out or remains out, do not transport a child on the front passenger seat until the system has been repaired.

A child in a rear-facing child restraint on the front passenger seat will be seriously injured or even killed if the front passenger front air bag inflates.

- If you have to place a child in a forward-facing child restraint on the front passenger seat, move the seat as far back as possible, use the proper child restraint recommended for the age, size and weight of the child, and secure child restraint with the vehicle's seat belt according to the child seat manufacturer's instructions. For children larger than the typical 12-month-old child, the front passenger front air bag may or may not be activated.

### Occupant safety

#### Warning!



Infants and small children should never share a seat belt with another occupant. During an accident, they could be crushed between the occupant and seat belt.

A child's risk of serious or fatal injuries is significantly increased if the child restraints are not properly secured in the vehicle and/or the child is not properly secured in the child restraint.

Children too big for a toddler restraint must ride in seats using regular seat belts. Position shoulder belt across chest and shoulder, not face or neck. A booster seat may be necessary to achieve proper seat belt positioning for children over 41 lbs until they reach a height where a lap/shoulder belt fits properly without a booster.

When the child restraint is not in use, remove it from the vehicle or secure it with the seat belt to prevent the child restraint from becoming a projectile in the event of an accident.

Do not leave children unattended in the vehicle, even if the children are secured in a child restraint system. Unsupervised children in a child restraint system may use vehicle equipment and may cause an accident and/or serious personal injury.

### Installation of infant and child restraint systems

#### Warning!



Always lock backrest in its upright position when rear seat bench is occupied by passengers, before installing top tether straps, or the extended cargo compartment is not in use. Check for secure locking by pushing and pulling on the backrest. If the seat backrest is not properly locked, the seat backrest could fold. The child seat would no longer be properly supported or positioned to provide its intended benefit. That could cause serious or even fatal injuries.

This vehicle is equipped with tether anchorages for a top tether strap at each of the rear seating positions.

Top tether straps enable an additional connection to be made between child restraint systems secured with LATCH-type anchors and rear seats. This can further reduce the risk of injury.

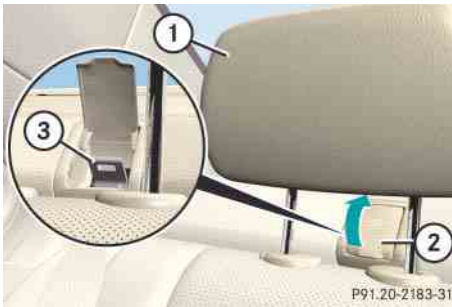

- ① Rear seat head restraint
- ② Cover of anchorage ring
- ③ Anchorage ring

- ▶ Move the respective head restraint ① to its uppermost position (▷ page 89).
- ▶ Lift up cover ② from anchorage ring ③.
- ▶ Guide tether strap between head restraint ① and top of seat back.
- ▶ Make sure the tether strap is not twisted.

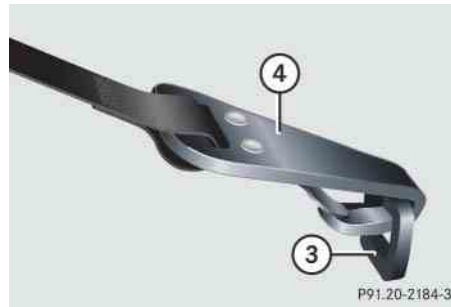

- ③ Anchorage ring
- ④ Top tether anchorage hook

- ▶ Securely fasten hook ④, which is part of the tether strap, to anchorage ring ③.

**i** For safety reasons, make sure hook ④ attaches to ring ③ beyond the safety catch, as illustrated.

- ▶ Lower head restraint ① if necessary (▷ page 89).

Make sure the top tether strap can pass freely between head restraint ① and top of seat backrest

Once the top tether anchorage hook ④ is attached, the child restraint itself can be secured.

- ▶ Install the child restraint system and tighten the top tether strap according to the child restraint manufacturer's instructions.

After removing the child restraint system and the top tether strap.

- ▶ Pull down and close cover ② from the respective anchorage ring ③.

### Child seat anchors – LATCH-type

This vehicle is equipped with two LATCH (Lower Anchors and Tethers for Children) type anchors (at each of the rear seats) for the installation of a LATCH-type child seat with matching mounting fittings.



## Occupant safety

### Warning!



Children too big for a toddler restraint must ride in seats using regular seat belts. Position shoulder belt across chest and shoulder, not face or neck.

A booster seat may be necessary to achieve proper seat belt positioning for children over 41 lbs until they reach a height where a lap/shoulder belt fits properly without a booster.

Install child seat according to manufacturer's instructions.

The child seat must be firmly attached to the right and left side anchors.

An incorrectly mounted child seat may come loose during an accident which could result in serious injury or death to the child.

Damaged or impact damaged child seats or child seat anchor fittings must be replaced.

Do not leave children unattended in the vehicle, even if the children are secured in a child restraint system.

**i** Non-LATCH type child seats may also be used and can be installed using the vehicle's seat belt system. Install child seat according to the manufacturer's instructions.

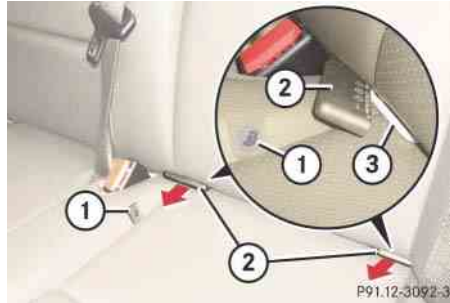

- ① Indicator
- ② Cover
- ③ Anchors

- ▶ Remove covers ① from anchors ③ by pulling it in direction of arrow.
- ▶ Store covers ①, for example in the storage compartment of the rear center armrest.

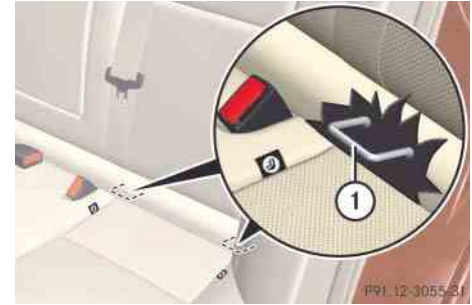

### Split rear bench seat\*

- ▶ Install child seat according to the manufacturer's instructions.

A rigid connection is established between the child seat and the body of the vehicle.

**!** Make sure the seat belt for the center seat can operate freely with a child seat installed.

### Blocking of rear door window operation

With the override switch you can disable the rear side window switches in the rear door panels.

#### Warning!



Activate the override switch when children are riding in the back seats of the vehicle. The children may otherwise injure themselves, e.g. by becoming trapped in the window opening.

When leaving the vehicle, always remove the SmartKey or SmartKey with KEYLESS-GO\* (Canada only) from the starter switch, take it with you, and lock your vehicle. Do not leave children unattended in the vehicle, or with access to an unlocked vehicle. A child's unsupervised access to a vehicle could result in an accident and/or serious personal injury.

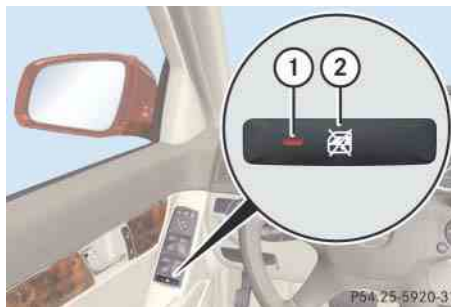

- ① Indicator lamp
- ② Override switch

► **Activating:** Press override switch ②.

Indicator lamp ① comes on.

The rear door windows can no longer be operated using the respective switch located in the rear doors.

**i** *Operation of the rear door windows with the switches located in the driver's door is still possible.*

► **Deactivating:** Press override switch ② again.

Indicator lamp ① goes out.

The rear door windows can again be operated using the respective switch located in the rear doors.

For more information on power windows, see the “Controls in detail” section (► page 120).

## Panic alarm



### ① PANIC button

#### **i** USA only:

*This device complies with Part 15 of the FCC Rules. Operation is subject to the following two conditions:*

- (1) This device may not cause harmful interference, and*
- (2) this device must accept any interference received, including interference that may cause undesired operation.*

*Any unauthorized modification to this device could void the user's authority to operate the equipment.*

#### **i** Canada only:

*This device complies with RSS-210 of Industry Canada. Operation is subject to the following two conditions:*

- (1) This device may not cause interference, and*
- (2) this device must accept any interference received, including interference that may cause undesired operation of the device.*

*Any unauthorized modification to this device could void the user's authority to operate the equipment.*

- ▶ **Activating:** Press and hold **PANIC** button for at least 1 second.

An audible alarm and flashing exterior lamps will operate briefly.

- ▶ **Deactivating:** Press **PANIC** button again.

or

- ▶ Insert the SmartKey or the SmartKey with KEYLESS-GO\* (Canada only) in starter switch.

or

- ▶ Press the KEYLESS-GO\* start/stop button (Canada only) (▷ page 84).

The SmartKey with KEYLESS-GO\* (Canada only) must be inside the vehicle.

## ▼ Driving safety systems

This section contains information about the following driving safety systems:

- ABS (Antilock Brake System)
- Adaptive Brake
- BAS (Brake Assist System)
- EBP (Electronic Brake Proportioning)
- ESP® (Electronic Stability Program)
- 4MATIC (Four Wheel Electronic Traction System)

### Warning!



The following factors increase the risk of accidents:

- Excessive speed, especially in turns
- Wet and slippery road surfaces
- Following another vehicle too closely

The driving safety systems described in this section cannot reduce these risks or prevent the natural laws of physics from acting on the vehicle.

Always adapt your driving style to the prevailing road and weather conditions and keep a safe distance to other road users and objects on the street.

**i** In winter operation, the maximum effectiveness of the ABS, BAS, EBP, ESP® and 4MATIC is only achieved with winter tires (▷ page 360), or snow chains as required.

### ABS

### Warning!



Do not pump the brake pedal. Use firm, steady brake pedal pressure instead. Pumping the brake pedal defeats the purpose of the ABS and significantly reduces braking effectiveness.

The Antilock Brake System (ABS) regulates the brake pressure so that the wheels do not lock during braking. This allows you to maintain the ability to steer your vehicle.

The ABS is functional above a speed of approximately 5 mph (8 km/h) independent of road surface conditions.

On slippery road surfaces, the ABS will respond even to light brake pressure.

The  indicator lamp in the instrument cluster (▷ page 26) comes on when you switch on the ignition. It goes out when the engine is running.

### Braking

At the instant one of the wheels is about to lock up, a slight pulsation can be felt in the brake pedal, indicating that the ABS is in the regulating mode.

- ▶ Keep firm and steady pressure on the brake pedal while experiencing the pulsation. ▷▷

### Driving safety systems

▷▷ Continuous, steady brake pedal pressure yields the advantages provided by the ABS, namely braking power and the ability to steer the vehicle.

The pulsating brake pedal can be an indication of hazardous road conditions and functions as a reminder to take extra care while driving.

#### Emergency brake maneuver

- ▶ Keep continuous full pressure on the brake pedal.

#### Warning!



When the ABS is malfunctioning, the BAS, EBP, ESP® and hill start assist are also switched off.

When the ABS is malfunctioning, the wheels may lock during hard braking, reducing steering capability and extending the braking distance.

#### Warning!



The ABS cannot prevent the natural laws of physics from acting on the vehicle, nor can it increase braking or steering efficiency beyond that afforded by the condition of the vehicle brakes and tires or the traction afforded. The ABS cannot prevent accidents, including those resulting from excessive speed in turns, following another vehicle too closely, or hydroplaning.

Only a safe, attentive, and skillful driver can prevent accidents.

The capabilities of an ABS equipped vehicle must never be exploited in a reckless or dangerous manner which could jeopardize the user's safety or the safety of others.

For more information, see "Practical hints" (▷ page 374).

#### Adaptive Brake

Adaptive Brake provides a high level of braking safety as well as increased braking comfort. It is coupled with ABS, ESP® and BAS. Adaptive Brake takes driver and vehicle characteristics into consideration, thus achieving an optimal braking effect.

#### BAS

The Brake Assist System (BAS) operates in emergency situations. If you apply the brakes very quickly, the BAS automatically provides full brake boost, thereby potentially reducing the braking distance.

- ▶ Apply continuous full braking pressure until the emergency braking situation is over.

The ABS will prevent the wheels from locking.

When you release the brake pedal, the brakes function again as normal. The BAS is then deactivated.

**Warning!**

When the BAS is malfunctioning, the brake system is still functioning normally, but without the additional brake boost available that BAS would normally provide in an emergency braking maneuver. Therefore, the braking distance may increase.

**Warning!**

The BAS cannot prevent the natural laws of physics from acting on the vehicle, nor can it increase braking efficiency beyond that afforded by the condition of the vehicle brakes and tires or the traction afforded. The BAS cannot prevent accidents, including those resulting from excessive speed in turns, following another vehicle too closely, or hydroplaning. Only a safe, attentive, and skillful driver can prevent accidents.

The capabilities of a BAS equipped vehicle must never be exploited in a reckless or dangerous manner which could jeopardize the user's safety or the safety of others.

For more information, see “Practical hints” section (▷ page 374).

**EBP**

The Electronic Brake Proportioning (EBP) enhances braking effectiveness by allowing the rear brakes to supply a greater proportion of the braking effort in straight line braking without a loss of vehicle stability.

**Warning!**

If the EBP malfunctions, the ABS, BAS, ESP<sup>®</sup> and hill start assist are also switched off.

If the EBP is malfunctioning, the brake system will still function with full brake boost. However, the rear wheels could lock up during emergency braking situations, for example. You could lose control of the vehicle and cause an accident. Adapt your driving style to the changed driving characteristics.

### Driving safety systems

#### ESP®

The Electronic Stability Program (ESP®) is operational as soon as the engine is running and monitors the vehicle's traction (force of adhesive friction between the tires and the road surface) and handling.

The ESP® recognizes when a wheel is spinning or if the vehicle starts to skid. By applying brakes to the appropriate wheel and by limiting the engine output, the ESP® works to stabilize the vehicle. The ESP® is especially useful while driving off and on wet or slippery road surfaces. The ESP® also stabilizes the vehicle during braking and steering maneuvers.

The ESP® warning lamp  in the instrument cluster flashes when the ESP® is engaged.

The ESP® warning lamp  in the instrument cluster comes on when you switch on the ignition (▷ page 82). It goes out when the engine is running.

#### Warning!



Never switch off the ESP® when you see the ESP® warning lamp  flashing in the instrument cluster. In this case proceed as follows:

- While driving off, apply as little throttle as possible.
- While driving, ease up on the accelerator.
- Adapt your speed and driving style to the prevailing road conditions.

Failure to observe these guidelines could cause the vehicle to skid.

The ESP® cannot prevent accidents resulting from excessive speed.

#### Warning!



The ESP® cannot prevent the natural laws of physics from acting on the vehicle, nor can it increase the traction afforded. The ESP® cannot prevent accidents, including those resulting from excessive speed in turns, or hydroplaning. Only a safe, attentive, and skillful driver can prevent accidents. The capabilities of an ESP® equipped vehicle must never be exploited in a reckless or dangerous manner which could jeopardize the user's safety or the safety of others.

 *The cruise control is switched off when the ESP® engages.*

 *The ESP® will only function properly if you use wheels of the recommended tire size (▷ page 467).*

**!** *Vehicles without 4MATIC:*

Because the ESP® operates automatically, the engine and ignition must be shut off (SmartKey in starter switch position **0** or **1** or KEYLESS-GO (Canada only) start/stop button\* in position **0** or **1**) when

- the parking brake is being tested on a brake test dynamometer
- the vehicle is being towed with the front axle raised

Active braking action through the ESP® may otherwise seriously damage the brake system.

For information on vehicles with 4MATIC, see “Four wheel electronic traction system (4MATIC) with the ESP®” (e page 65).

For more information, see “Practical hints” section (▷ page 380) and (▷ page 387).

**Electronic traction system**

The electronic traction system is a component of ESP®.

The electronic traction system improves the vehicle’s ability to utilize available traction, especially under slippery road conditions by applying the brakes to a spinning wheel.

When you switch off the ESP®, the electronic traction system is still enabled.

**Warning!**

If you are driving too fast, the electronic traction system cannot reduce the risk of an accident.

The electronic traction system cannot prevent the natural laws of physics from acting on the vehicle.

**Switching off the ESP®****Warning!**

The ESP® should not be switched off during normal driving other than in the circumstances described below. Disabling of the system will reduce vehicle stability in standard driving maneuvers.

Do not switch off the ESP® when a Minispare wheel is mounted.

To improve the vehicle’s traction, switch off the ESP® in driving situations where it would be advantageous to have the drive wheels spin and thus cut into surfaces for better grip such as:

- when driving with snow chains
- in deep snow
- in sand or gravel



## Driving safety systems

### Warning!



Switch on the ESP<sup>®</sup> immediately if the aforementioned circumstances do not apply anymore. Otherwise the ESP<sup>®</sup> will not stabilize the vehicle when it is starting to skid or a wheel is spinning.

When you switch off the ESP<sup>®</sup>

- the ESP<sup>®</sup> does not stabilize the vehicle
- the engine output is not limited, which allows the drive wheels to spin and thus cut into surfaces for better grip
- the electronic traction system will still apply the brakes to a spinning wheel
- the ESP<sup>®</sup> continues to operate when you are braking
- you cannot activate the cruise control
- the cruise control switches off if currently activated

**i** When the ESP<sup>®</sup> is switched off and one or more drive wheels are spinning, the ESP<sup>®</sup> warning lamp  in the instrument cluster flashes. However, the ESP<sup>®</sup> will then not stabilize the vehicle.



### ① ESP<sup>®</sup> off/on

- ▶ With the engine running, press ESP<sup>®</sup> switch ① until the ESP<sup>®</sup> warning lamp  in the instrument cluster comes on.

The ESP<sup>®</sup> is switched off.

### Warning!



When the ESP<sup>®</sup> warning lamp  is illuminated continuously, the ESP<sup>®</sup> is switched off or is not operational due to a malfunction. Vehicle stability in standard driving maneuvers reduces.

Adapt your speed and driving to the prevailing road conditions and to the non-operating status of the ESP<sup>®</sup>.

**!** Avoid spinning of a drive wheel for an extended period with the ESP<sup>®</sup> switched off. This may cause serious damage to the drivetrain which is not covered by the Mercedes-Benz Limited Warranty.

### Switching on the ESP<sup>®</sup>

- ▶ Press ESP<sup>®</sup> switch ①.

The ESP<sup>®</sup> warning lamp  in the instrument cluster goes out.

You are now again in normal driving mode with the ESP<sup>®</sup> switched on.

### Four wheel electronic traction system (4MATIC) with the ESP®

Models with all-wheel-drive only.

The 4MATIC improves vehicle's ability to use available traction, e.g. during winter operation in mountains under snowy conditions, by applying power to all four wheels.

#### Warning!



If you see the ESP® warning lamp  flashing in the instrument cluster, proceed as follows:

- While driving off, apply as little throttle as possible
- While driving, ease up on the accelerator
- Adapt your speed and driving style to the prevailing road conditions

Failure to observe these guidelines could cause the vehicle to skid.

The ESP® cannot prevent accidents resulting from excessive speed.

**!** Do not tow with one axle raised.

*Otherwise the transfer case can be damaged, which is not covered by the Mercedes-Benz Limited Warranty.*

**!** Performance testing must only be conducted on a two-axle dynamometer.

*Otherwise the transfer case can be damaged, which is not covered by the Mercedes-Benz Limited Warranty.*

**!** Because the ESP® operates automatically, the engine must be shut off (SmartKey in starter switch position **0** or **1** or KEYLESS-GO (Canada only) start/stop button\* in position **0** or **1**) when the parking brake is being tested on a brake test dynamometer.

*Active braking action through the ESP® may otherwise seriously damage the front or rear axle brake system.*

*Operational tests with the engine running can only be conducted on a two-axle dynamometer.*

**i** At highly demanding operating conditions, the electronic traction system may temporarily switch off to prevent overheating of the drive wheel brakes. The message *Currently Unavailable* See Operator's Manual will then appear in the multifunction display while the ESP® warning lamp  is flashing. The ESP® is still functioning normally.

## Anti-theft systems

### Immobilizer

The immobilizer prevents unauthorized persons from starting your vehicle.

When leaving the vehicle, always take the SmartKey or SmartKey with KEYLESS-GO\* (Canada only) with you and lock the vehicle. The engine can be started by anyone with a valid SmartKey or SmartKey with KEYLESS-GO\* (Canada only) that is left inside the vehicle.

### Activating

- ▶ **With the SmartKey:** Remove the SmartKey from the starter switch.
- ▶ **With the KEYLESS-GO\* (Canada only):** Turn off the engine and open the driver's door.

### Deactivating

- ▶ Switch on the ignition.

**i** Starting the engine will also deactivate the immobilizer.

*In case the engine cannot be started (yet the vehicle's battery is charged), the system is not operational. Contact an authorized Mercedes-Benz Center or call 1-800-FOR-MERCEDES (in the USA), or 1-800-387-0100 (in Canada).*

### Anti-theft alarm system

Once the alarm system has been armed, a visual and audible alarm is triggered when someone opens:

- a door
- the trunk
- the hood

The alarm will stay on even if the activating element (a door, for example) is immediately closed.

The alarm system will also be triggered when

- the vehicle is opened with the mechanical key.

- a door is opened from the inside.
- the trunk is opened with the emergency release button.

To cancel the alarm after it has been triggered, see “Canceling the alarm” (▷ page 67).

**i** If the alarm stays on for more than 30 seconds, a call to the Response Center is initiated automatically by the Tele Aid\* system (▷ page 295) provided Tele Aid\* service was subscribed to and properly activated, and that necessary mobile phone, power supply and GPS coverage are available.



① Indicator lamp

- ▶ **Arming:** Lock the vehicle with the SmartKey or KEYLESS-GO\* (Canada only).

The turn signal lamps flash three times, and an acoustic signal sounds three times, to indicate that the alarm system is armed.

Indicator lamp ① begins to flash after approximately 15 seconds after arming the alarm system.

**i** If the turn signal lamps do not flash three times, and the acoustic signal does not sound three times, one of the following elements may not be properly closed:

- a door
- the trunk

the alarm system is armed.

*With a door open, close the door and lock the vehicle again. The turn signal lamps flash three times, and an acoustic signal sounds three times, to indicate that the alarm system is armed and the vehicle is locked. If you open the unlocked door again the alarm system will be triggered.*

*With the trunk open, close the trunk lid. The vehicle will lock and the turn signal lamps flash three times, and an acoustic signal sounds three times, to indicate that the alarm system is armed and the vehicle is locked.*

- ▶ **Disarming:** Unlock your vehicle with the SmartKey or KEYLESS-GO\* (Canada only).

The turn signal lamps flash once, and an acoustic signal sounds once, to indicate that the alarm system is disarmed.



**i** The vehicle will lock and the alarm system will rearm automatically after approximately 40 seconds if neither a door nor the trunk lid was opened.

### Canceling the alarm

To cancel the alarm, do one of the following:

- ▶ Insert the SmartKey or SmartKey with KEYLESS-GO\* (Canada only) in the starter switch.

or

- ▶ Press the  or  button on the SmartKey or SmartKey with KEYLESS-GO\* (Canada only).

In vehicles with KEYLESS-GO\* (Canada only):

- ▶ Grasp an outside door handle.

The SmartKey with KEYLESS-GO (Canada only) must be within 3 ft (1 m) of the vehicle.

or

- ▶ Press the KEYLESS-GO (Canada only) start/stop button (▷ page 84).

The SmartKey with KEYLESS-GO (Canada only) must be inside the vehicle.



Locking and unlocking  
Starter switch positions

Seats

Steering wheel

Mirrors

Memory function\* (Canada only)

Fastening the seat belts

Lighting

Windshield wipers

Power windows

Driving and parking

Manual transmission

Automatic transmission\*

Instrument cluster

Control system

Audio system

Driving systems

Air vents

Dual-zone automatic climate control

3-zone automatic climate control\* (Canada only)

Trunk

Power tilt/sliding sunroof

Panorama roof with power tilt/sliding panel\*

Loading and storing

Useful features



### Locking and unlocking

#### SmartKey

Your vehicle comes supplied with two SmartKeys, each with remote control and a removable mechanical key.





The SmartKey provides an extended operating range. To prevent theft, however, it is advisable to only unlock the vehicle when you are in close proximity to it.

The SmartKey centrally locks and unlocks, when set to factory settings (▷ page 71):

- the doors
- the trunk
- the fuel filler flap



#### SmartKey with remote control

- ①  Lock button
- ②  Opening button for trunk (▷ page 269)
- ③ Mechanical key locking tab
- ④  Unlock button
- ⑤ Battery check lamp
- ⑥  PANIC Panic button (▷ page 58)

**!** *To prevent possible malfunction, avoid exposing the SmartKey to high levels of electromagnetic radiation.*

#### Warning!



When leaving the vehicle, always remove the SmartKey from the starter switch, take it with you, and lock the vehicle. Do not leave children unattended in the vehicle, or with access to an unlocked vehicle. A child's unsupervised access to a vehicle could result in an accident and/or serious personal injury.

#### Warning!



To prevent possible personal injury, always keep hands and fingers away from the door or trunk lid opening when closing a door or the trunk. Be especially careful when small children are around.

Before closing doors, make sure there is no possibility of someone getting caught in a door during closing.

**i** USA only:

This device complies with Part 15 of the FCC Rules. Operation is subject to the following two conditions:

- (1) This device may not cause harmful interference, and
- (2) this device must accept any interference received, including interference that may cause undesired operation.

Any unauthorized modification to this device could void the user's authority to operate the equipment.

**i** Canada only:

This device complies with RSS-210 of Industry Canada. Operation is subject to the following two conditions:

- (1) This device may not cause interference, and
- (2) this device must accept any interference received, including interference that may cause undesired operation of the device.

Any unauthorized modification to this device could void the user's authority to operate the equipment.

**i** You can also open and close the door windows and tilt/sliding sunroof, or the panorama roof with power tilt/ sliding panel\* using the SmartKey (▷ page 123).

**!** If you cannot lock or unlock the vehicle with the SmartKey, then either the batteries in the SmartKey are discharged, the SmartKey is malfunctioning or the vehicle batteries are drained.

- Check the batteries in the SmartKey and replace them if necessary (▷ page 428).
- Use the mechanical key to unlock the driver's door (▷ page 424) and trunk (▷ page 425).
- Use the mechanical key to lock and trunk (▷ page 272).
- Have the vehicle batteries and their connections checked (▷ page 446).

If the SmartKey is malfunctioning, contact Roadside Assistance or an authorized Mercedes-Benz Center.

### Factory setting

**i** Your vehicle is equipped with an acoustic lock and unlock confirmation signal feature. An acoustic signal will sound when the vehicle is locked or unlocked using the SmartKey.

If you wish to activate or deactivate the feature, or adjust its signal volume, contact an authorized Mercedes-Benz Center.

► **Global unlocking:** Press button .

- All turn signal lamps flash once.
- An acoustic signal sounds once.
- The locking knobs in the doors move up.
- The anti-theft alarm system is disarmed.
- The locator lighting will also come on if it is dark and the feature is activated in the control system (▷ page 172).



### Locking and unlocking

The vehicle will lock again automatically and rearm the anti-theft alarm system within approximately 40 seconds of unlocking if:

- neither a door nor the trunk is opened
- the SmartKey is not inserted in the starter switch
- the central locking/unlocking switch is not activated



► **Global locking:** Press button .

With the trunk and doors closed:

- All turn signal lamps flash three times.
- An acoustic signal sounds three times.
- The locking knobs in the doors move down.
- The anti-theft alarm system is armed.

#### Selective setting

If you frequently travel alone, you may wish to reprogram the SmartKey so that pressing button  only unlocks the driver's door and the fuel filler flap.

- Press and hold buttons  and  simultaneously for about 6 seconds until battery check lamp  (▷ page 70) flashes twice.

The SmartKey will then function as follows:

- **Unlocking driver's door and fuel filler flap:** Press button .
- All turn signal lamps flash once.
  - An acoustic signal sounds once.
  - The locking knob in the driver's door moves up.
  - The anti-theft alarm system is disarmed.

- The locator lighting will also come on if it is dark and the feature is activated in the control system (▷ page 172).



► **Global unlocking:** Press button  twice.

- All turn signal lamps flash once.
- An acoustic signal sounds once.
- The locking knobs in the doors move up.
- The anti-theft alarm system is disarmed.
- The locator lighting will also come on if it is dark and the feature is activated in the control system (▷ page 172).

► **Global locking:** Press button .

With the trunk and doors closed:

- All turn signal lamps flash three times.
- An acoustic signal sounds three times.
- The locking knobs in the doors move down.
- The anti-theft alarm system is armed.

► **Restoring to factory setting:** Press and hold buttons  and  simultaneously for about 6 seconds until battery check lamp  (▷ page 70) flashes twice.

### SmartKey with KEYLESS-GO\* (Canada only)

Vehicles equipped with KEYLESS-GO come with two SmartKeys with KEYLESS-GO, each with remote control and a removable mechanical key.

The KEYLESS-GO function is integrated into the SmartKey. On these vehicles, the validity of the SmartKey with KEYLESS-GO is checked every time you grasp an outside door handle.

With the KEYLESS-GO function, you can lock and unlock the vehicle without using the remote control buttons on the SmartKey and start the engine without inserting the SmartKey in the starter switch.







The SmartKey with KEYLESS-GO centrally locks and unlocks, when set to factory settings (▷ page 76):

- the doors
- the trunk
- the fuel filler flap



P80.35-2285-31

### SmartKey with KEYLESS-GO

-  Lock button
-  Opening button for trunk (▷ page 269)
-  Locking tab for mechanical key
-  Unlock button
-  Battery check lamp
-  PANIC Panic button (▷ page 58)

 *When any outside door handle other than the driver's outside door handle is grasped, the vehicle is always centrally unlocked.*

 *To prevent possible malfunction, avoid exposing the SmartKey with KEYLESS-GO to high levels of electromagnetic radiation.*

### Locking and unlocking

#### Warning!



When leaving the vehicle, always take the SmartKey with KEYLESS-GO\* with you and lock the vehicle. Do not leave children unattended in the vehicle, or with access to an unlocked vehicle. A child's unsupervised access to a vehicle could result in an accident and/or serious personal injury.

They could start the vehicle with a valid SmartKey with KEYLESS-GO left in the vehicle or with the KEYLESS-GO button on the starter switch, or they could release the parking brake, thereby putting themselves and others in danger. Switch off the engine and take the SmartKey with KEYLESS-GO with you even if you are only leaving the vehicle for a short while.

#### Warning!



To prevent possible personal injury, always keep hands and fingers away from the door or trunk lid opening when closing a door or the trunk. Be especially careful when small children are around.

Before closing doors, make sure there is no possibility of someone getting caught in a door during closing.

#### USA only:

*This device complies with Part 15 of the FCC Rules. Operation is subject to the following two conditions:*

- (1) This device may not cause harmful interference, and*
- (2) this device must accept any interference received, including interference that may cause undesired operation.*

*Any unauthorized modification to this device could void the user's authority to operate the equipment.*

#### Canada only:

*This device complies with RSS-210 of Industry Canada. Operation is subject to the following two conditions:*

- (1) This device may not cause interference, and*
- (2) this device must accept any interference received, including interference that may cause undesired operation of the device.*

*Any unauthorized modification to this device could void the user's authority to operate the equipment.*

 *You can also open and close the door windows and tilt/sliding sunroof, or the panorama roof with power tilt/ sliding panel\* using the SmartKey with KEYLESS-GO (▷ page 123).*

 *If you cannot lock or unlock the vehicle with the SmartKey with KEYLESS-GO, then either the batteries in the SmartKey with KEYLESS-GO are discharged, the SmartKey with KEYLESS-GO is malfunctioning or the vehicle batteries are drained.*

- *Check the batteries in the SmartKey with KEYLESS-GO and replace them if necessary (▷ page 428).*

- Use the mechanical key to unlock the driver's door (▷ page 424) and trunk (▷ page 425).
- Use the mechanical key to lock and trunk (▷ page 272).
- Have the vehicle batteries and their connections checked (▷ page 446).

If the SmartKey with KEYLESS-GO is malfunctioning, contact Roadside Assistance or an authorized Mercedes-Benz Center.

### Important notes on using KEYLESS-GO

- You can also use the SmartKey with KEYLESS-GO like a normal SmartKey (▷ page 70).  
The starter switch is under the KEYLESS-GO button. Pull the KEYLESS-GO button out in order to access the starter switch.
- You can combine KEYLESS-GO functions with normal SmartKey functions (e.g. unlocking with KEYLESS-GO and locking with button ).
- Always carry the SmartKey with KEYLESS-GO with you.

- Never store the SmartKey with KEYLESS-GO together with:
  - Electronic items such as a telephone or another SmartKey with KEYLESS-GO
  - Metallic objects such as coins or metal foil

Doing so could impair the function of the KEYLESS-GO system.

- To lock or unlock the vehicle, the SmartKey with KEYLESS-GO must be located outside the vehicle within approximately 3 ft (1 m) of a door or the trunk lid.
- If the vehicle has been parked for more than 72 hours, you must pull an outside door handle in order to activate the KEYLESS-GO function.
- In order to start the engine with the SmartKey with KEYLESS-GO:
  - The SmartKey with KEYLESS-GO must be located in the vehicle.

- The KEYLESS-GO start/stop button must be inserted in the starter switch (▷ page 84).
- The brake pedal must be firmly depressed. Do not depress the accelerator.
- If the SmartKey with KEYLESS-GO is positioned farther away from the vehicle, the system may no longer recognize the SmartKey with KEYLESS-GO. The vehicle then cannot be locked or the engine started via the KEYLESS-GO system.
- If the SmartKey with KEYLESS-GO is removed from the vehicle (e.g. if passenger exits the vehicle with the SmartKey with KEYLESS-GO)
  - when pressing the KEYLESS-GO start/stop button or trying to lock the vehicle with the outside door handle the message *Key not recognized* appears in the multifunction display

### Locking and unlocking

- with the engine running, the message **Key not recognized** appears in the multifunction display while driving off

Find the SmartKey with KEYLESS-GO or change its present location immediately (e.g. place it on the front passenger seat or insert it in shirt pocket).

- If you have started the engine with the KEYLESS-GO start/stop button, you can turn it off again with:
  - the KEYLESS-GO start/stop button
  - the SmartKey with KEYLESS-GO inserted in the starter switch, when the gear selector lever is in position **P**

- Remember that the engine can be started by anyone with a SmartKey with KEYLESS-GO that is left inside the vehicle.

Possibility 1: (One SmartKey with KEYLESS-GO in the vehicle, one SmartKey with KEYLESS-GO outside the vehicle):

If you leave the SmartKey with KEYLESS-GO behind when exiting and locking the vehicle, no message appears in the multifunction display.

Possibility 2: (One SmartKey with KEYLESS-GO in the vehicle, no SmartKey with KEYLESS-GO outside the vehicle):

When exiting and trying to lock the vehicle, the message **Key still in vehicle** appears in the multifunction display. The vehicle will not be locked.

### Factory setting

**i** Your vehicle is equipped with an acoustic lock and unlock confirmation signal feature. An acoustic signal will sound when the vehicle is locked or unlocked using the SmartKey with KEYLESS-GO.

*If you wish to activate or deactivate the feature, or adjust its signal volume, contact an authorized Mercedes-Benz Center.*

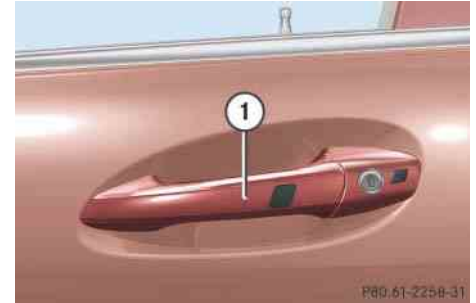

① Outside door handle

- ▶ **Global unlocking:** Grasp an outside door handle ①.
  - All turn signal lamps flash once.
  - An acoustic signal sounds once.
  - The locking knobs in the doors move up.
  - The anti-theft alarm system is disarmed.
  - The locator lighting will also come on if it is dark and the feature is activated in the control system (▷ page 172).

The vehicle will lock again automatically and rearm the anti-theft alarm system within approximately 40 seconds of unlocking if:

- neither a door nor the trunk is opened
- the central locking/unlocking switch is not activated

**i** *The vehicle could inadvertently be unlocked if the SmartKey with KEYLESS-GO is within 3 ft (1 m) of the vehicle and:*

- *an outside door handle is splashed with water, or*
- *you attempt to clean an outside door handle.*

- ▶ **Global locking:** Close all doors and touch outside of door handle ①. Do not keep your hand in the door handle recess.

With the trunk and doors closed:

- All turn signal lamps flash three times.
- An acoustic signal sounds three times.
- The locking knobs in the doors move down.
- The anti-theft alarm system is armed.

**i** *You can also lock the vehicle using the KEYLESS-GO lock button on trunk lid, if equipped (▷ page 270).*

### Selective setting

If you frequently travel alone, you may wish to reprogram the SmartKey with KEYLESS-GO so when you, grasp the driver's outside door handle only the driver's door and the fuel filler flap unlocks.

- ▶ Press and hold buttons **Ⓜ** and **Ⓟ** simultaneously for about 6 seconds until battery check lamp ⑤ (▷ page 73) flashes twice.

The SmartKey with KEYLESS-GO will then function as follows:

- ▶ **Unlocking driver's door and fuel filler flap:** Grasp the driver's outside door handle.
  - All turn signal lamps flash once.
  - An acoustic signal sounds once.
  - The locking knob in the driver's door moves up.
  - The anti-theft alarm system is disarmed.





### Locking and unlocking

- ▷▷ • The locator lighting will also come on if it is dark and the feature is activated in the control system (▷ page 172).
- ▶ **Global unlocking:** Grasp any outside door handle other than the driver's outside door handle.
  - All turn signal lamps flash once.
  - An acoustic signal sounds once.
  - The locking knobs in the doors move up.
  - The anti-theft alarm system is disarmed.
  - The locator lighting will also come on if it is dark and the feature is activated in the control system (▷ page 172).
- ▶ **Global locking:** Close all doors and touch outside of a door handle ① (▷ page 76). Do not keep your hand in the door handle recess.

With the trunk and doors closed:

- All turn signal lamps flash three times.
- An acoustic signal sounds three times.
- The locking knobs in the doors move down.
- The anti-theft alarm system is armed.

**i** You can also lock the vehicle using the **KEYLESS-GO** lock button on trunk lid, if equipped (▷ page 270).

- ▶ **Restoring to factory setting:** Press and hold buttons  and  simultaneously for about 6 seconds until battery check lamp ⑤ (▷ page 73) flashes twice.

### Checking batteries in the SmartKey or SmartKey with KEYLESS-GO\* (Canada only)



- ▶ Press button  or .

The battery check lamp (▷ page 70) or (▷ page 73) comes on briefly to indicate that the SmartKey or SmartKey with KEYLESS-GO batteries are in order.

**!** If the battery check lamp does not come on briefly during check, the SmartKey or SmartKey with KEYLESS-GO batteries are discharged.

Replace the batteries (▷ page 428).

You can obtain the required batteries at any authorized Mercedes-Benz Center.

**i** If the batteries are checked within signal range of the vehicle, pressing button  or  will lock or unlock the vehicle accordingly.

### Loss of the SmartKey or SmartKey with KEYLESS-GO\* (Canada only)

If you lose your SmartKey, SmartKey with KEYLESS-GO or mechanical key, you should do the following:

- ▶ Have the SmartKey or SmartKey with KEYLESS-GO deactivated at an authorized Mercedes-Benz Center.
- ▶ Report the loss of the SmartKey, SmartKey with KEYLESS-GO or the mechanical key immediately to your car insurance company.
- ▶ Have the mechanical lock replaced if necessary.

Your authorized Mercedes-Benz Center will be glad to supply you with a replacement.

### Opening doors from the inside



You can open a locked door from the inside. Open door only when conditions are safe to do so.



- ① Locking knob
- ② Inside door handle

**i** If the vehicle has previously been locked with the SmartKey or KEYLESS-GO\*, opening a door from the inside will trigger the anti-theft alarm system.

To cancel the alarm, do one of the following:

- Insert the SmartKey or SmartKey with KEYLESS-GO\* in the starter switch.
- Press button  or  on the SmartKey or SmartKey with KEYLESS-GO\*.

In vehicles with KEYLESS-GO\*:

- Grasp an outside door handle.  
*The SmartKey with KEYLESS-GO\* must be within 3 ft (1 m) of the vehicle.*
- Press the KEYLESS-GO\* start/stop button ([▷ page 84](#)).  
*The SmartKey with KEYLESS-GO\* must be inside the vehicle.*

**i** If you hear a warning signal you have forgotten to switch off the low beam headlights or the parking lamps before opening the driver's door.

In addition the message **Switch Off Lights** appears in the multifunction display.

Switch off the low beam headlights or the parking lamps.

If the message **Switch Off Lights** or **Remove Key** appears in the multifunction display remove the SmartKey from the starter switch or switch off the automatic headlamp mode.



### Locking and unlocking

#### Front doors

- ▶ Pull on door handle ② on the respective front door to open door.  
If door was locked, locking knob ① will move up.

#### Rear doors

- ▶ Pull up locking knob ① on the respective rear door to unlock door.
- ▶ Pull on door handle ② on the respective rear door to open door.

#### Automatic central locking

The doors and the trunk automatically lock when the ignition is switched on and the wheels are turning at vehicle speeds of approximately 9 mph (15 km/h) or more. The locking knobs in the doors move down.

You can open a locked door from the inside. Open door only when conditions are safe to do so.

You could therefore lock yourself out when the vehicle is pushed or towed, or it is on a test stand.

#### Automatic central locking activating/deactivating

You can deactivate the automatic locking using the control system (▷ page 173).

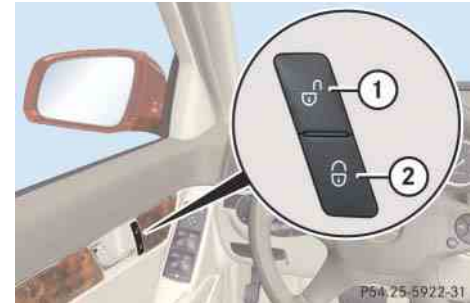

- ① Central unlocking switch
- ② Central locking switch

- ▶ **Activating:** Press and hold central locking switch ② until you hear a chime.
- ▶ **Deactivating:** Press and hold central unlocking switch ① until you hear a chime.

## Locking and unlocking from the inside

### Warning!



When leaving the vehicle, always remove the SmartKey or SmartKey with KEYLESS-GO\* from the starter switch, take it with you, and lock the vehicle. Do not leave children unattended in the vehicle, or with access to an unlocked vehicle. A child's unsupervised access to a vehicle could result in an accident and/or serious personal injury.

You can lock or unlock the doors and the trunk from the inside using the central locking or unlocking switch. This can be useful, for example, if you want to lock the vehicle before starting to drive.

The fuel filler flap will not be locked or unlocked with the central locking or unlocking switch, respectively.

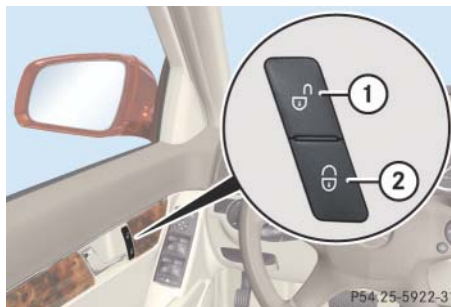

- ① Central unlocking switch
- ② Central locking switch

► **Unlocking:** Press central unlocking switch ①.

The vehicle unlocks.

► **Locking:** Press central locking switch ②.

If the front passenger door is closed, the vehicle locks.

**i** You can open a locked door from inside at any time. Open door only when conditions are safe to do so.

If the vehicle was previously locked with the central locking switch:

- and the SmartKey or SmartKey with KEYLESS-GO\* is set to factory settings, the complete vehicle is unlocked when a door is opened from the inside
- and the SmartKey or SmartKey with KEYLESS-GO\* is set to selective settings, only the door opened from the inside is unlocked

If the vehicle was previously centrally locked with the SmartKey or with KEYLESS-GO\*, it will not unlock using the central unlocking switch.

### Starter switch positions

#### Warning!



When leaving the vehicle, always remove the SmartKey or SmartKey with KEYLESS-GO\* from the starter switch, take it with you, and lock the vehicle. Do not leave children unattended in the vehicle, or with access to an unlocked vehicle. A child's unsupervised access to a vehicle could result in an accident and/or serious personal injury.

#### SmartKey



#### Starter switch

**0** For removing SmartKey

- 1** Power supply for some electrical consumers, such as seat adjustment
- 2** Ignition (power supply for all electrical consumers) and driving position. All lamps (except high beam headlamp indicator lamp and turn signal indicator lamps unless activated) in the instrument cluster come on. If a lamp in the instrument cluster fails to come on when the ignition is switched on, have it checked and replaced if necessary. If a lamp in the instrument cluster remains on after starting the engine or comes on while driving, refer to “Lamps in instrument cluster” (▷ page 374).

#### **3** Starting position

**i** When you switch on the ignition, the indicator and warning lamps (except high beam headlamp indicator lamp and turn signal indicator lamps unless activated) in the instrument cluster come on. The indicator and warning lamps (except high beam headlamp indicator lamp and turn signal indicator lamps if activated) should go out when the engine is running. This indicates that the respective systems are operational.

**i** Vehicles with automatic transmission\*: The SmartKey can only be removed from the starter switch with the gear selector lever in position **P**.

**i** If the SmartKey is left in starter switch position **0** for an extended period of time, it can no longer be turned in the switch. In this case, the steering is locked. To unlock, remove SmartKey from starter switch and reinsert.

**!** If the SmartKey cannot be turned in the starter switch, the battery may not be sufficiently charged.

- Check the battery and charge it if necessary (▷ page 446).
- Get a jump start (▷ page 451).

To prevent accelerated battery discharge or a completely discharged battery, always remove the SmartKey from the starter switch when the engine is not in operation.

For information on starting the engine using the SmartKey, see “Starting: Make sure the gear selector lever is set to **P**.” (▷ page 127).

### SmartKey with KEYLESS-GO\* (Canada only)

Vehicles equipped with the KEYLESS-GO feature are supplied with a SmartKey with integrated KEYLESS-GO function and a removable KEYLESS-GO start/stop button.

With the KEYLESS-GO start/stop button inserted and the SmartKey with KEYLESS-GO present in the vehicle, pressing the KEYLESS-GO start/stop button

- without the brake pedal depressed corresponds to the various starter switch positions (▷ page 84)
- with the brake pedal firmly depressed will start the engine (▷ page 128)

If you wish or should there be a need to insert the SmartKey with KEYLESS-GO in the starter switch, the KEYLESS-GO start/stop button can be easily removed by pulling it out of the starter switch.

**i** The function of the SmartKey overrides the KEYLESS-GO function.

**i** The KEYLESS-GO start/stop button does not need to be removed from the starter switch when you leave the vehicle. However, always take the SmartKey with KEYLESS-GO with you when you leave the vehicle. As long as the SmartKey with KEYLESS-GO is in the vehicle, the vehicle's electrical systems can be switched on or the engine can be started using the KEYLESS-GO start/stop button.

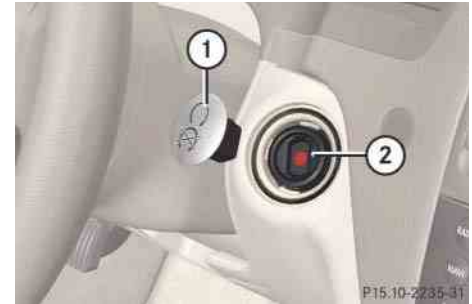

- ① KEYLESS-GO start/stop button
- ② Starter switch

► Insert KEYLESS-GO start/stop button ① into starter switch ② (if not inserted already).

**i** When you switch from SmartKey mode back to KEYLESS-GO mode, the system requires 2 seconds of detection time before you can use the KEYLESS-GO button as usual.



### Starter switch positions

▷▷ The SmartKey with KEYLESS-GO must be located in the vehicle.

- ▶ Make sure the gear selector lever is set to **P**.
- ▶ Do not depress the brake pedal.



- ① KEYLESS-GO start/stop button (Canada only)

#### Position 0

Before you press the KEYLESS-GO start/stop button, the vehicle's on-board electronics have status **0** (as with SmartKey removed).

#### Position 1

- ▶ Press the KEYLESS-GO start/stop button once.

This supplies power for some electrical consumers, such as seat adjustment.

**i** If you now press the KEYLESS-GO start/stop button

- once again, the ignition (position 2) is switched on
- twice, the power supply is again switched off

#### Ignition (or position 2)

- ▶ Press the KEYLESS-GO start/stop button twice.

This supplies power for all electrical consumers.

All lamps (except high beam headlamp indicator lamp and turn signal indicator lamps unless activated) in the instrument cluster come on. If a lamp in the instrument cluster fails to come on when the ignition is switched on, have it checked and replaced if necessary.

If a lamp in the instrument cluster remains on after starting the engine or comes on while driving, refer to "Lamps in instrument cluster" (▷ page 374).

**i** If you now press the KEYLESS-GO start/stop button once, the power supply is again switched off.

**i** When you switch on the ignition, the indicator and warning lamps (except high beam headlamp indicator lamp and turn signal indicator lamps unless activated) in the instrument cluster come on. The indicator and warning lamps (except high beam headlamp indicator lamp and turn signal indicator lamps if activated) should go out when the engine is running. This indicates that the respective systems are operational.

For information on starting the engine using the KEYLESS-GO start/stop button, see "Starting: Make sure KEYLESS-GO start/stop button is inserted in the starter switch (e page 83)." (▷ page 128).

## ▼ Seats

### Warning!



All seat, head restraint adjustments, as well as fastening of seat belts, must be done before the vehicle is put into motion.

## Seat adjustment

### Warning!



Do not adjust the driver's seat while driving. Adjusting the seat while driving could cause the driver to lose control of the vehicle.

Never ride in a moving vehicle with the seat back in an excessively reclined position as this can be dangerous. You could slide under the seat belt in a collision. If you slide under it, the seat belt would apply force at the abdomen or neck. That could cause serious or fatal injuries. The seat backrest and seat belts provide the best restraint when the wearer is in a position that is as upright as possible and seat belts are properly positioned on the body.

Your seat must be adjusted so that you can correctly fasten your seat belt.

Observe the following points:

- Adjust the seat backrest until your arms are slightly angled when holding the steering wheel.
- Adjust the seat to a comfortable seating position that still allows you to reach the accelerator/brake pedal safely. The position should be as far back as possible with the driver still able to properly operate controls.
- Adjust the head restraint so that it is as close to the head as possible and the center of the head restraint supports the back of the head at eye level.
- Never place hands under the seat or near any moving parts while a seat is being adjusted.

Failure to do so could result in an accident and/or serious personal injury.

### Warning!



When leaving the vehicle, always remove the SmartKey or SmartKey with KEYLESS-GO\* from the starter switch, take it with you, and lock the vehicle.

Even with the SmartKey or SmartKey with KEYLESS-GO\* (Canada only) removed from the starter switch or the SmartKey with KEYLESS-GO\* (Canada only) removed from the vehicle, the power seats can be operated.

Therefore, do not leave children unattended in the vehicle, or with access to an unlocked vehicle. A child's unsupervised access to a vehicle could result in an accident and/or serious personal injury.

## Seats

### Warning!



According to accident statistics, children are safer when properly restrained in the rear seating positions than in the front seating position. Thus, we strongly recommend that children be placed in the rear seats whenever possible. Regardless of seating position, children 12 years old and under must be seated and properly secured in an appropriately sized infant restraint, toddler restraint, or booster seat recommended for the size and weight of the child.

A child's risk of serious or fatal injuries is significantly increased if the child restraints are not properly secured in the vehicle and the child is not properly secured in the child restraint.

For additional information about children in the vehicle, see "Children in the vehicle" (▷ page 51).

### Power seat adjustment

The seat adjustment switch is located on the entry side of each front seat base. The seat adjustment switch for Canada vehicles with memory function\* are located on the front doors.

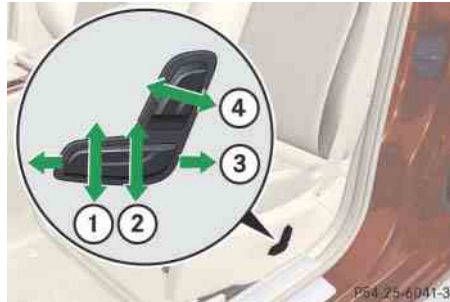

- ① Seat cushion tilt
- ② Seat height
- ③ Seat fore and aft
- ④ Seat backrest tilt

- ▶ Vehicles without memory function\*: Adjust the head restraint height manually (▷ page 87).

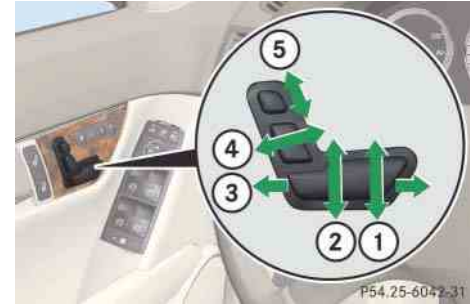

### Driver's door (Canada only)

- ① Seat cushion tilt
- ② Seat height
- ③ Seat fore and aft
- ④ Seat backrest tilt
- ⑤ Head restraint height (▷ page 87)

**i** After unlocking the vehicle or turning off the engine, the seat adjustment can be operated for up to approximately 3 minutes with the SmartKey or KEYLESS-GO\* (Canada only) in starter switch position **0** or removed from the starter switch.

Vehicles with memory function\* (Canada only): The memory function\* is operational at any time. Seat and steering wheel adjustment is always possible.

If it is not possible to adjust the seat with the seat adjustment switch:

- ▶ Insert the SmartKey or the KEYLESS-GO start/stop button\* (Canada only) into the starter switch.

or

- ▶ With SmartKey or KEYLESS-GO\* (Canada only) in starter switch position **0**. Turn the SmartKey in starter switch to position **1** or press the KEYLESS-GO start/stop button\* (Canada only) once.

or

- ▶ Open the driver's or front passenger door.

**i** *Canada only:*

*The memory function\* (▷ page 102) lets you store the settings for the seat positions together with the settings for the steering wheel and the exterior rear view mirrors.*

**!** *When moving the seat, make sure there are no items in the footwell or behind the seats. Otherwise you could damage the seats.*

- ▶ **Seat cushion tilt:** Press the switch up or down in the direction of arrow ① until your upper legs are lightly supported.
- ▶ **Seat height:** Press the switch up or down in the direction of arrow ②.
- ▶ **Seat fore and aft:** Press the switch forward or backward in the direction of arrow ③.
- ▶ **Seat backrest tilt:** Press the switch forward or backward in the direction of arrow ④.

## Adjusting front seat head restraints

### Warning!



For your protection, drive only with properly positioned head restraints.

Adjust the head restraint so that it is as close to the head as possible and the center of the head restraint supports the back of the head at eye level. This will reduce the potential for injury to the head and neck in the event of an accident or similar situation.

Do not drive the vehicle without the seat head restraints. Head restraints are intended to help reduce injuries during an accident.

You cannot remove the active head restraint on the driver's and front passenger's seat.

For removal contact an authorized Mercedes-Benz Center.

For information on active head restraints, see "Active head restraints" (▷ page 50).



## Seats

### Head restraint height

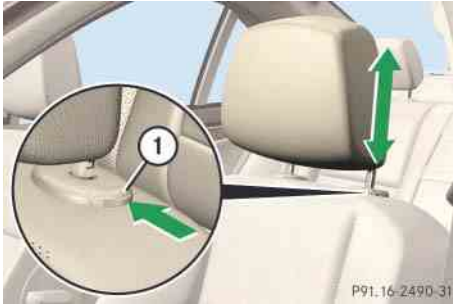

#### Head restraint height, manual adjusting

- ① Release button
- ▶ **Raising:** Manually adjust the height of the head restraint by pulling it upward.
- ▶ **Lowering:** To lower the head restraint, push release button ① and push down on the head restraint.

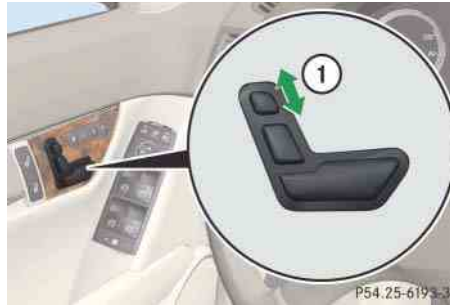

#### Head restraint height, electrical\* (Canada only)

- ① Head restraint height
- ▶ **Raising/lowering:** Press the switch up or down in the direction of arrow ① until the desired position is reached.

### Head restraint fore and aft adjustment



#### Head restraint adjusting

- Manually adjust the head restraint.
- ▶ Push or pull on the lower edge of the head restraint cushion to the desired position.

## Adjusting rear head restraints

### Warning!



For your protection, drive only with properly positioned head restraints.

Adjust the head restraint so that it is as close to the head as possible and the center of the head restraint supports the back of the head at eye level. This will reduce the potential for injury to the head and neck in the event of an accident or similar situation.

Do not drive the vehicle without the seat head restraints. Head restraints are intended to help reduce injuries during an accident.

## Rear head restraint height

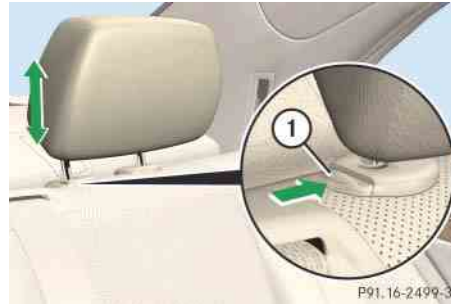

### Head restraint height

- ① Release button
- ▶ **Raising:** Manually adjust the height of the head restraint by pulling it upward.
- ▶ **Lowering:** To lower the head restraint, push release button ① and push down on the head restraint.

## Rear head restraint fore and aft adjustment



### Head restraint adjusting

You can adjust the angle of the two outer head restraints.

Manually adjust the head restraint.

- ▶ Push or pull on the lower edge of the head restraint cushion to the desired position.

### Seats

#### **Removing and installing rear seat head restraints (vehicles with split foldable rear seat)**

#### **Warning!**



For your protection, drive only with properly positioned head restraints.

Adjust the head restraint so that it is as close to the head as possible and the center of the head restraint supports the back of the head at eye level. This will reduce the potential for injury to the head and neck in the event of an accident or similar situation.

Do not drive the vehicle without the seat head restraints. Head restraints are intended to help reduce injuries during an accident.

**i** *The rear head restraints cannot be removed on vehicles which do not have the split foldable rear seat.*

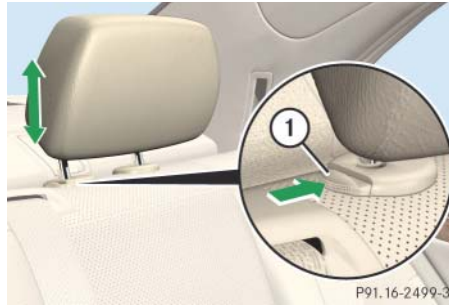

#### ① Release button

- ▶ **Removing:** Unlock the rear seat backrest and fold it slightly forward (▷ page 281).
- ▶ Pull head restraint to its highest position.
- ▶ Push release button ① and pull out head restraint.

▶ **Installing:** Position the head restraints so that the notches on the rod are on the left when looking in the direction of travel.

- ▶ Insert head restraint and push it down until it engages.
- ▶ Fold the rear seat backrest back until it engages (▷ page 282).
- ▶ Push release button ① and adjust head restraint to desired position.

**i** *Adjust the head restraint in such a way that it is as close to the head as possible.*

### Lumbar support

The curvature of the front seats can be adjusted to help enhance lower back support and seating comfort.

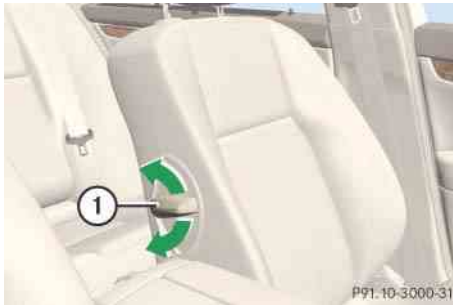

① Adjustment lever

- ▶ Move adjustment lever ① in direction of arrows until you have reached a comfortable seating position.

### Seat heating\*

The buttons for the front seats are located in the center console. The red indicator lamps on the button come on to show the selected heating level.



① Seat heating button

Level	
<b>3</b>	Three indicator lamps on (highest level)  The seat heating automatically switches to level 2 after approximately 5 minutes.
<b>2</b>	Two indicator lamps on  The seat heating automatically switches to level 1 after approximately 10 minutes.
<b>1</b>	One indicator lamp on (lowest level)  The seat heating automatically switches off after approximately 20 minutes.
<b>off</b>	No indicator lamp on

### Seats

- ▶ Switch on the ignition.
- ▶ **Switching on:** Press button ① repeatedly until the desired heating level is set.

One or more red indicator lamps on the button come on to show the selected heating level.

- ▶ **Switching off:** Press button ① repeatedly until all indicator lamps go out.

**i** *If one or more of the lamps on the seat heating button are flashing once, there is insufficient voltage available because too many electrical consumers are turned on. The seat heating switches off automatically.*

*The seat heating will switch back on again automatically as soon as sufficient voltage is available.*

## ▼ Steering wheel

### Warning!



Do not adjust the steering wheel while driving. Adjusting the steering wheel while driving, or driving without the steering wheel adjustment feature locked could cause the driver to lose control of the vehicle.

When leaving the vehicle, always remove the SmartKey or SmartKey with KEYLESS-GO\* (Canada only) from the starter switch, take it with you, and lock the vehicle.

Even with the SmartKey or SmartKey with KEYLESS-GO\* (Canada only) removed from the starter switch or the SmartKey with KEYLESS-GO\* (Canada only) removed from the vehicle, the electrical steering wheel adjustment feature can be operated. Therefore, do not leave children unattended in the vehicle, or with access to an unlocked vehicle. A child's unsupervised access to a vehicle could result in an accident and/or serious personal injury.

Make sure

- you can reach the steering wheel with your arms slightly bent at the elbows
- you can move your legs freely
- all displays (including malfunction and indicator lamps) on the instrument cluster are clearly visible

### Steering wheel adjustment, manual

#### Warning!



Only adjust the steering wheel with the vehicle at a standstill with the parking brake engaged and make sure the steering wheel is securely locked in place before driving off.

Driving without the steering wheel locked may cause unexpected steering wheel movement which could result in the driver losing control of the vehicle. Make sure the steering wheel is securely locked by trying to move it up and down, and in and out before driving off.

The handle for steering wheel adjustment is located below the steering column.

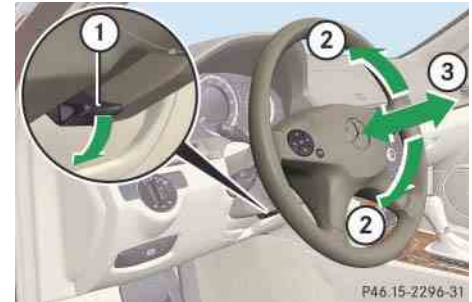

- ① Steering wheel adjustment release handle
- ② Steering wheel up/down
- ③ Steering wheel in/out

- ▶ To unlock the steering wheel, pull handle ① down to its stop limit.

The steering wheel is unlocked

- ▶ Move steering wheel to the desired position.



### Steering wheel

- ▷▷ To lock the steering wheel, push handle ① all the way up until it engages.

The steering wheel is locked into position again.

- ▶ Make sure the steering wheel is securely locked by trying to move it up and down, and in and out before driving off.

**!** Do not drive the vehicle until you have properly locked the steering wheel.

### Steering wheel adjustment, electrical\* (Canada only)

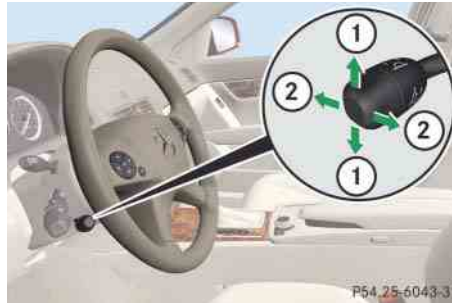

- ① Adjusting steering wheel, up or down
- ② Adjusting steering wheel, in or out

**i** The memory function\* is operational at any time. Seat and steering wheel adjustment is always possible.

The memory function\* (▷ page 102) lets you store settings for the steering wheel together with the settings for the seat position and the exterior rear view mirrors.

- ▶ **Adjusting steering wheel in or out:** Move stalk forward or back in the direction of arrow ② until a comfortable steering wheel position is reached with your arms slightly bent at the elbow.
- ▶ **Adjusting steering wheel up or down:** Move stalk up or down in the direction of arrow ①.

**Easy-entry/exit feature\* (Canada only)****Warning!**

You must make sure no one can become trapped or injured by the moving steering wheel when the easy-entry/exit feature is activated.

To stop steering wheel movement, do one of the following:

- Move steering wheel adjustment stalk.
- Press one of the memory position buttons or the memory button **M**.

Do not leave children unattended in the vehicle, or with access to an unlocked vehicle. Children could open the driver's door and unintentionally activate the easy-entry/exit feature, which could result in an accident and/or serious personal injury.

**Warning!**

Let the system complete the adjustment procedure before setting the vehicle in motion. All steering wheel adjustments must be completed before setting the vehicle in motion. Driving off with the steering wheel still adjusting could cause the driver to lose control of the vehicle.

This feature allows for easier entry into and exit from the vehicle. When entering and exiting the vehicle, the steering wheel is in its uppermost position.

The easy-entry/exit feature can be activated or deactivated in the Convenience sub-menu of the control system (▷ page 174).

With the easy-entry/exit feature activated the steering wheel tilts upwards when you:

- remove the SmartKey from the starter switch,  
or
- open the driver's door with the SmartKey in starter switch position **0** or **1** or the KEYLESS-GO\* start/stop button in position **1**

**i** *If the current position for the steering wheel is in the uppermost tilt position, the steering wheel will no longer be able to move upward when the easy-entry/exit feature is activated.*

*The adjustment procedure is briefly interrupted when the engine is started.*



### Steering wheel

With the easy-entry/exit feature activated, the steering wheel will return to their last set memory position when you:

- close the driver's door with the ignition switched on,  
or
- insert the SmartKey into the starter switch or press the KEYLESS-GO\* start/stop button once with the driver's door closed.

**i** *The last set steering wheel positions are stored when*

- *the ignition is switched off*
- *the position is stored in memory*  
(▷ *page 102*)

## ▼ Mirrors

Adjust the interior and exterior rear view mirrors before driving so that you have a good view of the road and traffic conditions.

### Interior rear view mirror

- ▶ Manually adjust the interior rear view mirror.

For more information, see “Interior rear view mirror, antiglare position” (▷ page 99) and, see “Auto-dimming rear view mirrors\*” (▷ page 100).

### Exterior rear view mirrors

#### Warning!



Exercise care when using the passenger side exterior rear view mirror. The mirror surface is convex (outwardly curved surface for a wider field of view). Objects in mirror are closer than they appear. Check your interior rear view mirror or glance over your shoulder before changing lanes.



- ① Driver's side exterior rear view mirror button
  - ② Passenger-side exterior rear view mirror button
  - ③ Adjustment button
- ▶ Switch on the ignition.
  - ▶ Press button ① for the driver's side exterior rear view mirror or button ② for passenger-side exterior rear view mirror.
- The indicator lamp in the respective button ① or ② comes on.
- If you do not make adjustments to the selected exterior rear view mirror within 15 seconds, the indicator lamp goes out. You will then have to select the desired exterior rear view mirror again before any adjustments can be made. Adjustments can only be made with the indicator lamp for the respective exterior rear view mirror button illuminated.
- ▶ Push adjustment button ③ up, down, left, or right according to the desired setting. ▷▷

### Mirrors

▷▷ **!** If an exterior rear view mirror housing is forcibly pushed forward (hit from the rear) or forcibly pushed rearward (hit from the front), reposition it by applying firm pressure until it snaps back into place. The mirror housing is then properly positioned and you can adjust the mirror in the usual manner.

**i** At low ambient temperatures, the exterior rear view mirrors will be heated automatically.

**i** Canada only:  
The memory function\* (▷ page 102) lets you store the setting for the exterior rear view mirrors together with the setting for the steering wheel and the seat positions.

#### Power folding exterior rear view mirrors\*

**!** Before driving the vehicle through an automatic car wash, fold the exterior mirrors in. Otherwise they may get damaged.

#### Folding exterior rear view mirrors in and out manually

The exterior rear view mirrors can vibrate if they are not folded out completely.



① Folds the exterior mirrors in and out

▶ Switch on the ignition.

▶ **Folding in:** Press button ①.

▶ **Folding out:** Press button ① again.

**!** If an exterior rear view mirror housing is forcibly pushed forward (hit from the rear), reposition it manually by applying firm pressure until it snaps back into place.

If an exterior rear view mirror housing is forcibly pushed rearward (hit from the front), press button ① to fold mirrors in, then press button ① again to fold mirrors out. Do not force mirrors by hand as this may damage the adjustment mechanism.

The mirror housing is then properly positioned and you can adjust the mirror in the usual manner.

### Folding exterior rear view mirrors in and out automatically

When the corresponding function in the control system is activated (▷ page 175):

- The exterior rear view mirrors automatically fold in as soon as the vehicle is locked from the outside.
- The exterior rear view mirrors automatically fold out as soon as the vehicle is unlocked and the driver's or front passenger door are subsequently opened.

**i** The mirrors do not fold out automatically if they were previously folded in manually with button ①.

**i** If you are driving at more than approximately 9 mph (15 km/h), you will not be able to fold the exterior mirrors in.

### Resetting the automatic exterior rear view mirror fold in function

You need to reset the automatic exterior rear view mirror fold in function whenever the battery was disconnected or discharged.

- ▶ Switch on the ignition.
- ▶ Briefly press button ①.

**i** You need to manually fold in the mirrors once, so that the automatic fold in function will work, see "Setting fold-in function\* for exterior rear view mirrors" (▷ page 175).

### Interior rear view mirror, antiglare position



① Lever

- ▶ Tilt the mirror to the antiglare position by moving lever ① towards the windshield.

The interior rear view mirror is dimmed.

### Mirrors

#### Auto-dimming rear view mirrors\*

The reflection brightness of the exterior rear view mirror on the driver's side and the interior rear view mirror will respond automatically to glare when

- the ignition is switched on  
and
- incoming light from headlamps falls on the sensor in the interior rear view mirror

The interior rear view mirror will not react if

- reverse gear **R** is engaged
- the interior lighting is turned on

#### Warning!



The auto-dimming function does not react if incoming light is not aimed directly at the sensors in the interior rear view mirror.

The interior rear view mirror and the exterior rear view mirror on the driver's side do not react, for example, if the rear window sunshade\* is in raised position.

Light hitting the mirror(s) at certain angles (incident light) could blind you. As a result, you may not be able to observe traffic conditions and could cause an accident.

#### Warning!



Exercise care when using the passenger-side exterior rear view mirror. The mirror surface is convex (outwardly curved surface for a wider field of view). Objects in mirror are closer than they appear. Check your interior rear view mirror or glance over your shoulder before changing lanes.

### Activating exterior rear view mirror parking position\* (Canada only)

Follow these steps to activate the mirror parking position so that the passenger-side exterior rear view mirror will be turned downward to the stored position.



- ① Driver's side exterior rear view mirror button
- ② Passenger-side exterior rear view mirror button
- ③ Adjustment button

- ▶ Make sure you have stored a parking position for the passenger-side exterior rear view mirror (▷ page 104).
- ▶ Switch on the ignition.
- ▶ Shift the transmission in reverse gear. The previously selected exterior rear view mirror is activated, and the indicator lamp in the respective button ① or ② comes on.
- ▶ Press button ②, to select the front passenger side exterior rear view mirror.

The indicator lamp in button ② comes on and the passenger-side exterior rear view mirror will be turned downward to the stored position.

The exterior rear view mirror returns to its previously stored driving position:

- 10 seconds after you have put the transmission out of reverse
- immediately once your vehicle exceeds a speed of approximately 6 mph (10 km/h)
- immediately when you press button ① for driver's side exterior rear view mirror.

### Memory function\* (Canada only)

Prior to operating the vehicle, the driver should check and adjust the seat height, seat position fore and aft, and seat backrest angle if necessary, to ensure adequate control, reach, and comfort. The head restraint should also be adjusted for proper height. See also the section on air bags (▷ page 36) for proper seat positioning.

In addition, adjust the steering wheel to ensure adequate control, reach, operation and comfort. Both the inside and outside rear view mirrors should be adjusted for adequate rear vision.

Fasten seat belts. Infants and small children should be seated in a properly secured restraint system that complies with U.S. Federal Motor Vehicle Safety Standards 213 and 225 and Canadian Motor Vehicle Safety Standards 213 and 210.2.

With the memory function you can store up to 3 different settings.

Each stored position on the driver's side includes the following settings:

- Seat position
- Steering wheel position
- Exterior rear view mirrors position

#### Warning!



Do not activate the memory function while driving. Activating the memory function while driving could cause the driver to lose control of the vehicle.

On passenger side, the seat position is stored on each memory position.

## Memory function\* (Canada only)



**M** Memory button

**1 2 3** Memory position buttons

**i** *The memory function\* is operational at any time. Seat and steering wheel adjustment is always possible.*

### Storing positions into memory\*

- ▶ Adjust the seat (▷ page 85) to the desired position.
- ▶ On the driver's side: Adjust the steering wheel (▷ page 93) and the exterior rear view mirrors (▷ page 97) to the desired position.
- ▶ Press memory button **M**.
- ▶ Release memory button **M** and press one of the memory position buttons within 3 seconds.

An acoustic signal sounds to confirm. The settings are stored with the selected position.

### Recalling positions from memory\*

**!** *Do not operate the power seats using the memory position button if the seat backrest is in an excessively reclined position. Doing so could cause damage to front or rear seats.*

*First move seat backrest to an upright position.*

- ▶ Press and hold memory position button until the seat, steering wheel and exterior rear view mirrors have completely moved to the stored positions.

**i** *Releasing the memory position button immediately stops movement to the stored positions.*



### Memory function\* (Canada only)

#### Storing exterior rear view mirror parking position\*

For easier parking, you can adjust the passenger-side exterior rear view mirror so that you can see the right rear wheel as soon as you engage the reverse gear.

For information on activating the parking position, see “Activating exterior rear view mirror parking position\* (Canada only)” (▷ page 101).

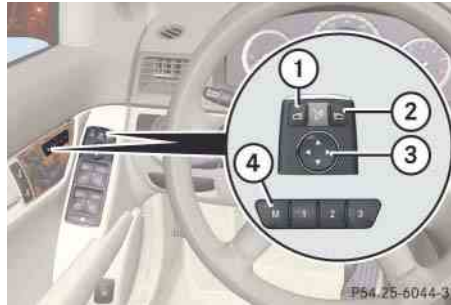

- ① Driver's side exterior rear view mirror button
- ② Passenger-side exterior rear view mirror button
- ③ Adjustment button
- ④ Memory button

- ▶ Stop the vehicle.
- ▶ Switch on the ignition.
- ▶ Press button ②.

The passenger-side exterior rear view mirror is selected.

- ▶ Adjust the passenger-side exterior rear view mirror with button ③ so that you see the rear wheel and the road curb.
- ▶ Press memory button ④.
- ▶ Within 3 seconds, press one of the arrows of adjustment button ③.

The parking position is stored if the mirror does not move.

**i** If the mirror does move, repeat the above steps. After the setting is stored, you can move the mirror again.

## ▼ Fastening the seat belts

### Warning!



Always fasten your seat belt before driving off. Always make sure all of your passengers are properly restrained.

Failure to wear and properly fasten and position your seat belt greatly increases your risk of injuries and their likely severity in an accident. You and your passengers should always wear seat belts.

If you are ever in an accident, your injuries can be considerably more severe without your seat belt properly buckled. Without your seat belt buckled, you are much more likely to hit the interior of the vehicle or be ejected from it. You can be seriously injured or killed.

In the same crash, the possibility of injury or death is lessened if you are wearing your seat belt. The air bags can only provide the protection they were designed to afford if the occupants are using their seat belts (▷ page 36).

### Warning!



According to accident statistics, children are safer when properly restrained in the rear seating positions than in the front seating position. Thus, we strongly recommend that children be placed in the rear seats whenever possible. Regardless of seating position, children 12 years old and under must be seated and properly secured in an appropriately sized infant restraint, toddler restraint, or booster seat recommended for the size and weight of the child.

A child's risk of serious or fatal injuries is significantly increased if the child restraints are not properly secured in the vehicle and the child is not properly secured in the child restraint.

For additional information on children in the vehicle, see "Children in the vehicle" (▷ page 51).

### Warning!



Never let more people ride in the vehicle than there are seat belts available. Be sure everyone riding in the vehicle is correctly restrained with a separate seat belt. Never use a seat belt for more than one person at a time.

### Warning!



Never ride in a moving vehicle with the seat backrest in an excessively reclined position as this can be dangerous. You could slide under the seat belt in a collision. If you slide under it, the seat belt would apply force at the abdomen or neck. That could cause serious or even fatal injuries. The seat backrest and seat belt provide the best restraint when the wearer is in a nearly upright position and the seat belt is properly positioned on the body.

### Fastening the seat belts

#### Warning!



Read and observe the additional warning notices printed in the “Safety and Security” section.



- ① Seat belt outlet
- ② Latch plate
- ③ Release button
- ④ Buckle

- ▶ Pull the seat belt smoothly from the seat belt outlet ①.
- ▶ Place the shoulder portion of the seat belt across the top of your shoulder and the lap portion across your hips.
- ▶ Push latch plate ② into buckle ④ until it clicks.
- ▶ If necessary, adjust the seat belt to the correct height (▷ page 107).
- ▶ If necessary, tighten the lap portion to a snug fit by pulling shoulder portion up.
- ▶ To release the seat belt, press release button ③ and guide latch plate ② back to seat belt outlet ①.

#### Proper use of seat belts

- Do not twist the seat belt when fastening.
- Adjust seat belt so that the shoulder portion is located as close as possible to the middle of the shoulder (it should not touch the neck). Never pass the shoulder portion of the seat belt under your arm.
- Position the lap belt as low as possible on your hips (over hip joint) and not across the abdomen.
- Place the seat backrest in a nearly upright position.
- Never use a seat belt for more than one person at a time.
- Do not fasten a seat belt around a person and another object at the same time. When using a seat belt to secure infant restraints or toddler restraints or children in booster seats, always follow the child seat manufacturer’s instructions.

- Check your seat belt during travel to make sure it is properly positioned.
- Make sure the seat belt is always fitted snugly. Take special care of this when wearing loose clothing.

### Warning!



Do not pass seat belts over sharp edges. They could tear.

Do not allow the seat belt to get caught in the door or in the seat adjustment mechanism. This could damage the seat belt.

Never attempt to make modifications to seat belts. This could impair the effectiveness of the seat belts.

Do not bleach or dye seat belts as this may severely weaken them. In a crash, they may not be able to provide adequate protection.

Damaged seat belts or seat belts that were highly stressed in an accident must be replaced. Contact an authorized Mercedes-Benz Center.

For more information, see “Seat belts” (▷ page 46).

### Seat belt height adjustment

You can adjust the height of the seat belt for the driver’s and front passenger seat.



① Release button

- ▶ **Raising:** Slide the seat belt height adjuster upward.

The seat belt height adjuster engages in different positions.

- ▶ **Lowering:** Press and hold release button ①.
- ▶ Slide the seat belt height adjuster downward.
- ▶ Release button ① and make sure the seat belt height adjuster engages into place.

### Lighting

**i** If you drive in countries where vehicles drive on the other side of the road than the country in which the vehicle is registered, you must have the headlamps modified for symmetrical low beams. Relevant information can be obtained at your authorized Mercedes-Benz Center.

#### Exterior lamp switch



1		Standing lamps, left (turn left two stops)
2		Standing lamps, right (turn left one stop)
3		Off Daytime running lamp mode (▷ page 110)
4		Automatic headlamp mode Daytime running lamp mode (▷ page 110)
5		Parking lamps (also side marker lamps, tail lamps, license plate lamps, instrument panel lamps)
6		Low beam headlamps or high beam headlamps
7		Front fog lamps
8		Rear fog lamp

**i** If you hear a warning signal you have forgotten to switch off the low beam headlamps or the parking lamps before opening the driver's door.

In addition the message Switch Off Lights appears in the multifunction display.

Switch off the low beam headlamps or the parking lamps.

If the message Switch Off Lights or Remove Key appears in the multifunction display remove the SmartKey from the starter switch or switch off the automatic headlamp mode.

**!** Failure to switch off the exterior lamps when leaving the vehicle may result in a discharged battery.

#### Low beam headlamps

The low beam headlamps can be switched on and off with the exterior lamp switch using the manual headlamp mode.

► **Switching on:** Turn the exterior lamp switch to position

The green indicator lamp in the exterior lamp switch comes on.

The following lamps switch on:

- Low beam headlamps
- Tail and parking lamps
- License plate lamps
- Side marker lamps

- ▶ **Switching off:** Turn the exterior lamp switch to position **0**.

The green indicator lamp  in the exterior lamp switch goes out.

### Automatic headlamp mode

The following lamps switch on and off automatically depending on the brightness of the ambient light:



- Low beam headlamps
- Tail and parking lamps
- License plate lamps
- Side marker lamps

### Warning!



If the exterior lamp switch is set to **A**, the headlamps will not be automatically switched on under foggy conditions.

To minimize risk to you and to others, activate headlamps by turning exterior lamp switch to position  when driving or when traffic and/or ambient lighting conditions require you to do so.

In low ambient lighting conditions, only switch from position **A** to  with the vehicle at a standstill in a safe location. Switching from position **A** to  will briefly switch off the headlamps. Doing so while driving in low ambient lighting conditions may result in an accident.

The automatic headlamp feature is only an aid to the driver. The driver is responsible for the operation of the vehicle's lights at all times.

- ▶ Turn the exterior lamp switch to position **A**.

With the SmartKey in starter switch position **1** or the KEYLESS-GO\* start/stop button (Canada only) pressed once, the tail and parking lamps, the license plate lamps and the side marker lamps will switch on and off depending on the brightness of the ambient light.

When the engine is running, the low beam headlamps, the tail and parking lamps, the license plate lamps, and the side marker lamps will switch on and off depending on the brightness of the ambient light.



*Canada only:*

*High beam headlamps are only available with the exterior lamp switch in position .*

### Lighting

#### Daytime running lamp mode

In Canada the daytime running lamp mode is mandatory and therefore in a constant mode.

In the USA the daytime running lamp mode is deactivated by default. Activate the daytime running lamp mode using the control system, see “Setting daytime running lamp mode (USA only)” (▷ page 171).

- ▶ Turn exterior lamp switch to position **0** or **A**.

When the engine is running, the low beam headlamps are switched on.

In low ambient light conditions, the following lamps will switch on additionally:

- Tail and parking lamps
- License plate lamps
- Side marker lamps

**i** With the daytime running lamp mode activated and the engine running, the low beam headlamps cannot be switched off manually.

#### Canada only

**i** With the exterior lamp switch in position **0** or **A**, you cannot switch on the high beam headlamps.



*The high beam flasher is available at all times.*

*For nighttime driving you should turn the exterior lamp switch to position  to permit activation of the high beam headlamps.*

Vehicles with automatic transmission\*:

When the engine is running and you shift from a driving position to position **N** or **P**, with the vehicle at a standstill the low beam headlamps will switch off with a delay of 3-minutes.

When the engine is running, and you

- turn the exterior lamp switch to position , the low beam headlamps, the tail and parking lamps, the license plate lamp and the side marker lamps switch on.
- turn the exterior lamp switch to position , the manual headlamp mode has priority over the daytime running lamp mode.



The corresponding exterior lamps switch on (▷ page 108).

#### USA only

**i** With the daytime running lamp mode activated and the exterior lamp switch in position **0**, you cannot switch on the high beam headlamps.

*The high beam flasher is available at all times.*

*For nighttime driving you should turn the exterior lamp switch to position  or **A** to permit activation of the high beam headlamps.*

When the engine is running, and you turn the exterior lamp switch to position  or , the manual headlamp mode has priority over the daytime running lamp mode.

The corresponding exterior lamps switch on (▷ page 108).



## Locator lighting and interior lighting delayed shut-off

The locator lighting and night security illumination are described in the “Control system” section, see “Setting locator lighting” (▷ page 172) and “Setting interior lighting delayed shut off” (▷ page 173).

## Fog lamps

### Warning!





In low ambient lighting or foggy conditions, only switch from position **A** to  with the vehicle at a standstill in a safe location. Switching from position **A** to  will briefly switch off the headlamps. Doing so while driving in low ambient lighting conditions may result in an accident.

**i** Fog lamps will operate with the parking lamps and/or the low beam headlamps on. Fog lamps should only be used in conjunction with low beam headlamps. Consult your State or Province Motor Vehicle Regulations regarding permissible lamp operation.

**i** Fog lamps cannot be switched on manually with exterior lamp switch in position **A**. To activate the fog lamps, turn exterior lamp switch to position  first.

### Front fog lamps

▶ Turn the exterior lamp switch to position  or  (▷ page 108).

▶ Pull out exterior lamp switch to first stop.

The front fog lamps are switched on.

The green indicator lamp  in the exterior lamp switch comes on (▷ page 108).

▶ Push in the exterior lamp switch.

The front fog lamps are switched off.

The green indicator lamp  in the exterior lamp switch goes out.

### Rear fog lamp (driver's side only)

▶ Turn the exterior lamp switch to position  (▷ page 108).

▶ Pull out exterior lamp switch to second stop.

The front fog lamps and the rear fog lamp switch on.

The yellow indicator lamp  in the exterior lamp switch comes on (▷ page 108).

▶ Push in the exterior lamp switch to first stop.

The rear fog lamp switches off.

The yellow indicator lamp  in the exterior lamp switch goes out.

The front fog lamps remain lit.



## Lighting

### Switching on high beams



#### Combination switch

- ① High beam
- ② High beam flasher

- ▶ **High beam:** Turn the exterior lamp switch to position  (▷ page 108).
- ▶ Push the combination switch in the direction of arrow ①.

The high beam indicator  in the instrument cluster comes on (▷ page 26).

- ▶ **High beam flasher:** Pull the combination switch briefly in the direction of arrow ②.

### Headlamp cleaning system\*

The headlamps are automatically cleaned with a high-pressure water jet when, at the same time,

- the engine is running
- the headlamps are switched on
- the windshield wipers have wiped the windshield with washer fluid for the first time.

The headlamps are cleaned every tenth time the windshield is washed with washer fluid.

When you switch off the headlamps or the ignition, the automatic function is reset and will start counting the next time from the beginning.

For information on filling up the washer reservoir, see “Windshield washer system and headlamp cleaning system\*” (▷ page 330).

### Corner-illuminating front fog lamps\* (With Bi-Xenon\* headlamps only)

The corner-illuminating front fog lamps improve illumination of the area in the direction into which you are turning.

The corner-illuminating front fog lamps will operate with the engine running and with:

- the exterior lamp switch in position  or **A** (▷ page 108)
- or
- the daytime running lamp mode activated (▷ page 110).

**i** The corner-illuminating front fog lamps will only come on in low ambient lighting conditions.

**i** If you are driving faster than 25 mph (40 km/h) or have the front fog lamps switched on, the corner-illuminating front fog lamps function is not available.

### Switching on corner-illuminating front fog lamps

- ▶ Switch on the left or right turn signal (> page 108), depending on whether you are turning left or right.

The respective corner-illuminating front fog lamp comes on and illuminates the area in the direction into which you are turning.

or

- ▶ Turn steering wheel in desired direction.

The corner-illuminating front fog lamp on the side of your steering direction comes on.

**i** If you have switched on the turn signal for one side but turn the steering wheel in the opposite direction, the corner-illuminating front fog lamp comes on for the side indicated by the turn signal.

*The corner-illuminating front fog lamp remains lit for a maximum of 3 minutes. Afterward, it goes out even if the turn signal is still switched on.*

**i** The corner-illuminating lamps temporarily come on both sides of the vehicle if you turn the steering wheel in one direction and then in the other direction shortly thereafter.

**i** The corner-illuminating lamps will come on automatically depending on the steering angle, even if you did not switch on either turn signal. If the corner-illuminating lamps came on automatically, they will also go out automatically depending on the steering angle.

**i** When you shift the transmission in reverse gear, the corner-illuminating lamp opposite to your steering direction comes on.

*The turn signal has no influence on the corner-illuminating lamp on the outside of the curve.*

### Switching off the corner-illuminating lamps

The combination switch for the turn signal resets automatically after major steering wheel movements. This will switch off the corner-illuminating lamps if they were activated by switching on the left or right turn signal.

If the turn signal should stay on after making the turn, the turn signal and corner-illuminating lamp can be switched off by returning the combination switch to its original position.

**i** The corner-illuminating lamp may remain lit for a short time. The corner-illuminating lamp comes on for no more than 20 seconds with the vehicle standing still. It is then switched off even if the turn signal is still switched on or you have turned the steering wheel to full lock.

### Lighting

#### Hazard warning flasher

The hazard warning flasher can be switched on at all times, even with the SmartKey removed from the starter switch or with the SmartKey with KEYLESS-GO\* removed from the vehicle.

The hazard warning flasher is automatically switched on if

- an air bag has been triggered
- you brake the vehicle strongly at a speed of more than 50 mph (70 km/h) and bring it to a complete stop



① Hazard warning flasher switch

- ▶ **Switching on:** Press hazard warning flasher switch.

All turn signals will flash.

**i** *With the hazard warning flasher activated and the combination switch set for either left or right turn, only the respective left or right turn signals will operate when the SmartKey in the starter switch is in position 1 or 2 or the KEYLESS-GO\* start/stop button (Canada only) (▷ page 84) is pressed once or twice.*

- ▶ **Switching off:** Press hazard warning flasher switch again.

If the hazard warning flasher was activated automatically, press hazard warning flasher switch ① twice to switch off the hazard warning flasher. The hazard warning flasher switched off automatically at vehicle speeds of approximately 6 mph (10 km/h) or more.

#### Interior lighting

##### Overhead control panel



- ① Rear interior lighting on/off
- ② Interior lighting control
- ③ Right reading lamp on/off
- ④ Front interior lighting on/off
- ⑤ Left reading lamp on/off
- ⑥ Left/right reading lamp
- ⑦ Front interior lamps

**!** An interior lamp switched on manually does not go out automatically.

*Leaving an interior light switch in the ON position for extended periods of time with the engine turned off could result in a discharged battery.*

### Automatic control

**i** The interior lighting is factory-set to automatic mode.

► **Deactivating:** Press button ②.

The button engages when pressed in. Automatic control of the interior lighting is deactivated.

The interior lighting remains switched off in darkness, even when you:

- unlock the vehicle
- open a door
- remove the SmartKey from the starter switch

► **Activating:** Press button ② again.

The button returns to its original position and sits flush with the other buttons. Automatic control of the interior lighting is activated.

The interior lighting switches on in darkness, when you:

- unlock the vehicle
- open a door
- remove the SmartKey from the starter switch

The interior lighting switches off automatically.

You can set whether the interior lighting should come on when you remove the key from the starter switch via the control system, see “Setting interior lighting delayed shut-off” (▷ page 173).

**i** If the door remains open, the interior lighting switches off automatically after approximately 5 minutes.

### Manual control

► **Switching on/off front interior lighting:** Press button ④.

► **Switching on/off rear interior lighting:** Press button ①.

► **Switching on/off front reading lamps:** Press button ③ or ⑤.

The left and right front reading lamps are located in the lower edge of the interior rear view mirror.

### Lighting

#### Interior lighting in the rear

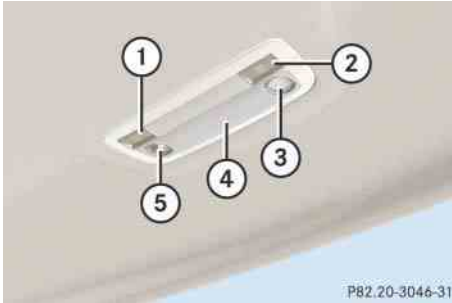

- ① Right rear reading lamp on/off
- ② Left rear reading lamp on/off
- ③ Left reading lamp
- ④ Rear interior lamp
- ⑤ Right reading lamp

► **Switching on/off rear reading lamps:** Press button ① or ②.

The respective left or right rear reading lamp comes on.

Switch the rear interior lamp on/off with the button in the overhead control panel.

#### Door entry lamps

For better orientation in the dark, the corresponding door entry lamps will switch on in darkness when you open a door and the automatic control is activated.

The door entry lamps switch off when the corresponding door is closed.

**i** If you turn the SmartKey in the starter switch to position **0** and switch off the exterior headlamps, the door entry lamps will remain lit for approximately 5 minutes.

#### Trunk lamp

The trunk lamp switches on if the trunk is opened.

If the trunk remains open, the trunk lighting switches off automatically after approximately 10 minutes.

## ▼ Windshield wipers



### Combination switch

- ① Switching on windshield wipers
- ② Single wipe  
Wiping with windshield washer fluid

**!** If the windshield wipers leave smears on the windshield after the car has been driven through an automatic car wash, then wax or other residue is on the windshield. Shortly after washing the car in an automatic car wash, clean the windshield with windshield washer fluid.

**!** Do not operate the windshield wipers when the windshield is dry. Dust that accumulates on a windshield might scratch the glass and/or damage the wiper blades when wiping occurs on a dry windshield. If it is necessary to operate the windshield wipers in dry weather conditions, always operate the windshield wipers with windshield washer fluid.

**!** If anything blocks the windshield wipers (leaves, snow, etc.), switch them off immediately.

- For safety reasons, stop the vehicle in a safe location and,
  - remove the SmartKey from starter switch
  - or
  - turn off the engine by pressing the KEYLESS-GO\* start/stop button and open the driver's door (with the driver's door open, starter switch is in position **0**, same as with SmartKey removed from starter switch)
- engage the parking brake before attempting to remove any blockage.
- Remove blockage.
- Turn the windshield wipers on again.





If the windshield wipers fail to function at all in combination switch position **•••** or **••••**,

- set the combination switch to the next higher wiper speed
  - have the windshield wipers checked at the nearest authorized Mercedes-Benz Center
- ▶ Switch on the ignition.

### Windshield wipers

#### Switching on/off windshield wipers

- ▶ Turn the combination switch to the desired position depending on the intensity of the rain.

-  Windshield wipers off
-  Slow intermittent wiping (rain sensor\* operation with low sensitivity)
-  Fast intermittent wiping (rain sensor\* operation with high sensitivity)
-  Slow continuous wiping
-  Fast continuous wiping

 *When the windshield wipers are switched on and you brake the vehicle to a stop, the wipers operate more slowly.*

#### Single wipe

- ▶ Press the combination switch briefly in the direction of arrow ② (▷ page 117) to the resistance point.

The windshield wipers wipe one time without washer fluid.

#### Intermittent wiping

Only switch on intermittent wiping under wet weather conditions or in the presence of precipitation.

 *Vehicles with rain sensor\*:  
Do not leave windshield wipers in intermittent setting when the vehicle is taken to an automatic car wash or during windshield cleaning. Wipers will operate in the presence of water sprayed on the windshield, and the windshield wipers may be damaged as a result.*

 *Vehicles with rain sensor\*:  
If you have set intermittent wiping, dirt on the surface of the rain sensor or optical effects may cause the windshield wipers to wipe in an undesired fashion. This could then damage the windshield wiper blades or scratch the windows. You should therefore switch off the windshield wipers when weather conditions are dry.*

- ▶ Turn the combination switch to position **...** or **....**.

Intermittent wiping starts with selected wiping interval.

Vehicles with rain sensor\*:

After the initial wipe, pauses between wipes are automatically controlled by the rain sensor.

Intermittent wiping interval is dependent on wetness of windshield.

**i** *Intermittent wiping is interrupted when the vehicle is at a standstill and a front door is opened. This protects persons getting into or out of the vehicle from being sprayed.*

*Intermittent wiping will be continued when*

- *all doors are closed*  
*and*
- *the clutch pedal is depressed (vehicles with manual transmission)*  
*or*
- *the gear selector lever is position **D** or **R** (vehicles with automatic transmission\*)*  
*or*
- *the wiper setting is changed using the combination switch*

### Wiping with windshield washer fluid

- ▶ Press the combination switch in the direction of arrow ② (▷ page 117) past the resistance point.

The windshield wiper operates with washer fluid.

**i** *To prevent smears on the windshield or noisy/chattering wiper blades, wipe with windshield washer fluid every now and then even when it is raining.*

**i** *Vehicles with headlamp cleaning system\*: The headlamp cleaning system\* will clean the headlamps automatically after the first and every tenth time windshield washer fluid is used while the engine is running (▷ page 112).*

For information on filling up the washer reservoir, see “Windshield washer system and headlamp cleaning system\*” (▷ page 330).



### Power windows

#### Opening and closing power windows

The door windows are opened and closed electrically. The switches

- for all door windows are on the driver's door
- for the front passenger door window are on the front passenger door
- for each rear door window are on the respective rear door



- ① Left front door window
- ② Right front door window
- ③ Right rear door window
- ④ Override switch
- ⑤ Left rear door window

#### Warning!



Do not keep any part of your body up against the side window pane when opening a window. The downward motion of the pane may pull that part of your body down between the window pane and the door frame and trap it there. If there is a risk of entrapment, release the switch and press it again to close the window.

#### Warning!





When closing the windows, make sure there is no danger of anyone being harmed by the closing procedure.

Activate the override switch (▷ page 57) when children are riding in the back seats of the vehicle. The children may otherwise injure themselves, e.g. by becoming trapped in the window opening.

The closing of the door windows can be immediately halted by releasing the switch or, if the switch was pressed past the resistance point and released, by pressing the lower part of the respective switch again.

The door windows are equipped with the express-close and automatic reversal function. If the window encounters an obstruction that blocks its path in a circumstance where you pressed the switch past the resistance point and released it to close the window, the automatic reversal function will stop the window and open it slightly.

If the window encounters an obstruction that blocks its path in a circumstance where you are closing the window by pressing and holding the switch, by pressing and holding button  on the SmartKey or SmartKey with KEYLESS-GO\*, by pressing and holding the sensor surface (vehicles with KEYLESS-GO\*) on an outside door handle, or by pressing and holding button  on the climate control panel (Canada only), the automatic reversal function will not operate.



When leaving the vehicle, always remove the SmartKey or SmartKey with KEYLESS-GO\* from the starter switch, take it with you, and lock the vehicle. Do not leave children unattended in the vehicle, or with access to an unlocked vehicle. A child's unsupervised access to a vehicle could result in an accident and/or serious personal injury.

 You can also open or close the windows using the SmartKey, see “Summer opening feature” (▷ page 123) and “Convenience closing feature” (▷ page 124).



 Operating the windows from the rear is not possible if you activate the override switch (▷ page 57).

 With the SmartKey in starter switch position **0** or removed from the starter switch, the power windows can be operated:

- until you open the driver's or front passenger door
  - for approximately 5 minutes if no door was opened
- Switch on the ignition (▷ page 82).

► **Opening:** Press the desired switch  to  (▷ page 120) to the resistance point.

The corresponding window will move down until you release the switch.

► **Closing:** Pull the desired switch  to  (▷ page 120) to the resistance point.

The corresponding window will move up until you release the switch.

### Warning!



If you press and hold the switch up when closing the window, and upward movement of the window is blocked by some obstruction including but not limited to arms, hands, fingers, etc., the automatic reversal will not operate.



### Power windows

- ▷▷▶ **Express-opening:** Press the switch ① to ④ (▷ page 120) past the resistance point and release.

The corresponding window opens completely.

- ▶ **Express-closing:** Pull the switch ① to ④ (▷ page 120) past the resistance point and release.

The corresponding window closes completely.

#### Warning!



Driver's door only:

If within 5 seconds you again press the switch past the resistance point and release, the automatic reversal will not operate.

#### Warning!



If a window is blocked while closing and reopens, it can be closed with greater force if you pull the switch to the resistance point within 2 seconds.

If the window is blocked again and reopens, you can close it with deactivated anti-trap protection by pulling the switch again to the resistance point within 2 seconds.

When closing windows with the anti-trap protection deactivated, make sure no one can become trapped, as this could result in serious or fatal injuries.

**!** *If the upward movement of the window is blocked during the closing procedure, the window will stop and open slightly. Remove the obstruction, press the respective power window switch again past the resistance point and release. If the window still does not close when there is no obstruction, press and hold the respective power window switch. The side window will then close without the protection of the automatic reversal feature.*

- ▶ **Stopping during Express-operation:** Briefly press the respective power window switch again.

### Summer opening feature

If the weather is warm, you can ventilate the vehicle before driving off by simultaneously:



- opening the side windows
- opening the tilt/sliding sunroof or panorama roof with power tilt/sliding panel\* and roller sunblinds

**i** The “Summer opening” function can only be activated via the remote control of the SmartKey or SmartKey with KEYLESS-GO\*.





- ▶ Aim transmitter eye of the SmartKey towards the sensor in the driver's outside door handle. The SmartKey must be in close proximity to the driver's door handle.
- ▶ Press button  to unlock the vehicle.

### Vehicles with tilt/sliding sunroof



- ▶ Press and hold button  until the side windows and tilt/sliding sunroof have reached the desired position.
- ▶ Release button  to interrupt procedure.

### Vehicles with panorama roof\*

If roller sunblinds are retracted:

- ▶ Press and hold button . The side windows and roller sunblinds begin to open/extend after approximately 1 second.
- ▶ With the side windows and roller blinds fully opened/extended, press and hold button  again. The tilt/sliding panel tilts and opens.

If roller sunblinds are extended:

- ▶ Press and hold button . The side windows move down and the tilt/sliding panel tilts and opens after approximately 1 second.
- ▶ Release button  to interrupt procedure.

### Power windows

#### Convenience closing feature

When you lock the vehicle, you can close the side windows and tilt/sliding sunroof or panorama roof with tilt/sliding panel\* simultaneously.

Afterward, you can close the roller sunblinds\* of the panorama tilt/sliding sunroof\*.



**i** The function of the SmartKey overrides the KEYLESS-GO function.

#### Warning!



When closing the windows and the tilt/sliding sunroof or panorama roof with tilt/sliding panel\*, make sure there is no danger of anyone being harmed by the closing procedure.

If potential danger exists, proceed as follows:

- Release button  to stop the closing procedure. To open, press and hold button . To continue the closing after making sure that there is no danger of anyone being harmed by the closing procedure, press and hold button .

Vehicles with KEYLESS-GO\* (Canada only):



- Release the sensor surface on the outside door handle (> page 125) to stop the closing procedure.
- Immediately pull on the same outside door handle and hold firmly. The side windows and the tilt/sliding sunroof or panorama roof with tilt/sliding panel\* will open for as long as the outside door handle is held but the door is not opened.

#### Vehicles with SmartKey





- ▶ Aim transmitter eye of the SmartKey towards the sensor in the driver's outside door handle. The SmartKey must be in close proximity to the driver's door handle.
- ▶ Press button  to lock the vehicle.

#### Vehicles with tilt/sliding sunroof

- ▶ Press and hold button  until the side windows and the tilt/sliding sunroof are completely closed.
- ▶ Release button  to interrupt procedure.

### Vehicles with panorama roof\*

- ▶ Press and hold button  until the side windows and the tilt/sliding panel are completely closed.
- ▶ Press and hold button  again.  
The roller sunblinds close.
- ▶ Release button  to interrupt procedure.

### Vehicles with KEYLESS-GO\* (Canada only)

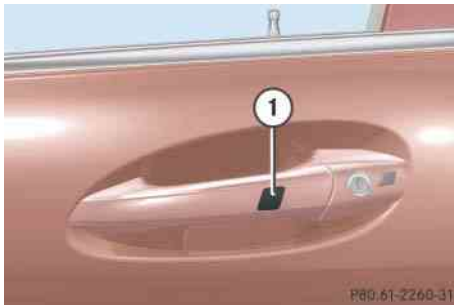

① Sensor surface on door handle

The SmartKey with KEYLESS-GO must be located outside the vehicle within approximately 3 ft (1 m) of a door.

- ▶ Close all doors.

### Vehicles with tilt/sliding sunroof

- ▶ Touch and hold sensor surface ① until the windows and the tilt/sliding sunroof are completely closed.

 *Make sure you are only touching the sensor surface.*

- ▶ Release sensor surface ① to interrupt procedure.

### Vehicles with panorama roof\*

- ▶ Touch and hold sensor surface ① until the side windows and the tilt/sliding panel are completely closed.

 *Make sure you are only touching the sensor surface.*

- ▶ Touch and hold sensor surface ① again.

The roller sunblinds close.

- ▶ Release sensor surface ① to interrupt procedure.

### Driving and parking

#### Warning!



Make sure absolutely no objects are obstructing the pedals' range of movement. Keep the driver's footwell clear of all obstacles. If there are any floor mats or carpets in the footwell, make sure the pedals still have sufficient clearance.

During sudden driving or braking maneuvers the objects could get caught between the pedals. You could then no longer brake or accelerate. This could lead to accidents and injury.

#### Starting the engine

#### Warning!



Inhalation of exhaust gas is hazardous to your health. All exhaust gas contains carbon monoxide (CO), and inhaling it can cause unconsciousness and possible death.

Do not run the engine in confined areas (such as a garage) which are not properly ventilated. If you think that exhaust gas fumes are entering the vehicle while driving, have the cause determined and corrected immediately. If you must drive under these conditions, drive with at least one window fully open.

#### Manual transmission

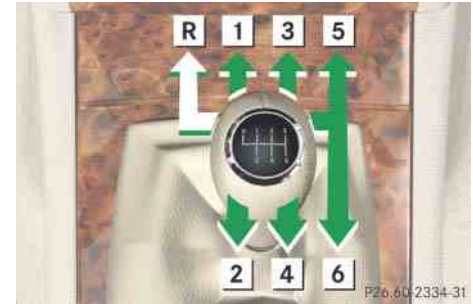

#### Gearshift pattern for manual transmission

For more information, see “Manual transmission” (> page 136).

- ▶ **Starting:** Depress brake pedal.
- ▶ Make sure the gearshift lever is in neutral position (no gear selected).
- ▶ Fully depress clutch pedal.  
Otherwise the engine cannot be started due to the integrated safety interlock.
- ▶ Do not depress the accelerator.
- ▶ Turn the SmartKey in the starter switch to position **3** and hold until the engine starts.

For information on turning off the engine, see “Turning off the engine” (▷ page 134).

### Automatic transmission\*



### Gearshift pattern for automatic transmission

- P** Park position
- R** Reverse gear
- N** Neutral
- D** Drive position

For more information on how to operate the gear selector lever, see “Automatic transmission\*” (▷ page 127).

### SmartKey

- ▶ **Starting:** Make sure the gear selector lever is set to **P**.
- ▶ Do not depress the accelerator.
- ▶ Turn the SmartKey in the starter switch to position **3** and hold until the engine starts.

**i** You can also use the “touch-start” function. Turn the SmartKey to position **3** and release it again immediately. The engine then starts automatically.

**i** You can also start the engine with the automatic transmission set to **N**.

For information on turning off the engine with the SmartKey, see “Turning off the engine” (▷ page 134).



### Driving and parking

#### KEYLESS-GO\* (Canada only)

##### Warning!



As long as the SmartKey with KEYLESS-GO is in your vehicle, the vehicle can be started. Therefore, never leave children unattended in the vehicle, as they could otherwise accidentally start the engine.

When leaving the vehicle, always take the SmartKey with KEYLESS-GO with you and lock the vehicle. Do not leave children unattended in the vehicle, or with access to an unlocked vehicle. A child's unsupervised access to a vehicle could result in an accident and/or serious personal injury.

You can start your vehicle without the SmartKey in the starter switch using the KEYLESS-GO start/stop button on the starter switch.

The SmartKey with KEYLESS-GO must be located in the vehicle.



#### ① KEYLESS-GO\* start/stop button (Canada only)

- ▶ **Starting:** Make sure KEYLESS-GO start/stop button is inserted in the starter switch (▷ page 83).
- ▶ Make sure the gear selector lever is set to **P**.
- ▶ Depress the brake pedal during the starting procedure.
- ▶ Do not depress the accelerator.
- ▶ Press KEYLESS-GO start/stop button once.

The engine starts if the SmartKey with KEYLESS-GO is in the vehicle.

**i** You can also start the engine with the automatic transmission set to **N**.

**i** If you wish to start the vehicle with the SmartKey instead of the KEYLESS-GO feature, remove the KEYLESS-GO start/stop button from the starter switch and proceed as described in “Starting with the SmartKey” (▷ page 127).

For information on turning off the engine with KEYLESS-GO, see “Turning off the engine” (▷ page 134).

## Starting difficulties

**!** Remember that extended starting attempts can drain the battery.

### **The engine does not start. You can hear the starter.**

There could be a malfunction

- in the engine electronics, or
- in the fuel supply system

Carry out the following steps:

- ▶ If you are starting the engine with the SmartKey: Turn SmartKey in starter switch to position **0** and repeat starting procedure (▷ page 126).
- ▶ If you are starting the engine with KEYLESS-GO\*: Close any doors that may be open to allow for better detection of the SmartKey with KEYLESS-GO\*.

or

- ▶ Remove the KEYLESS-GO\* start/stop button from starter switch.

- ▶ Start the engine with the SmartKey as radio signals from another source may be interfering with the SmartKey with KEYLESS-GO\*.

- ▶ Repeat the starting procedure (▷ page 126).

If the engine does not start after several starting attempts:

- ▶ Call Roadside Assistance.
- ▶ Notify an authorized Mercedes-Benz Center.

### **The engine does not start. You cannot hear the starter.**

The battery may not be sufficiently charged.

- ▶ Get a jump start (▷ page 451).

If the engine will not start despite a jump start:

- ▶ Call Roadside Assistance.
- ▶ Notify an authorized Mercedes-Benz Center.

## Driving off

### Warning!



When leaving the vehicle, always remove the SmartKey or SmartKey with KEYLESS-GO\* (Canada only) from the starter switch, take it with you, and lock the vehicle. Do not leave children unattended in the vehicle, or with access to an unlocked vehicle. Children could release the parking brake, which could result in an accident and/or serious personal injury.

### Warning!



On slippery road surfaces, never downshift in order to obtain braking action. This could result in drive wheel slip and reduced vehicle control. Your vehicle's ABS will not prevent this type of loss of control.

### Driving and parking

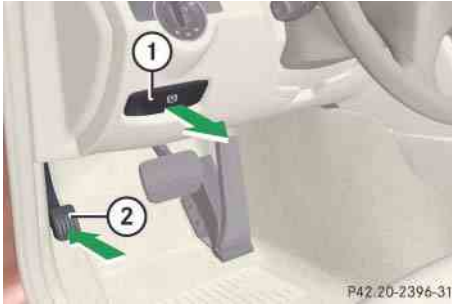

- ① Release handle
  - ② Parking brake pedal
- ▶ Release the parking brake by pulling on release handle ①.

The indicator lamp **BRAKE** (USA only) or **(P)** (Canada only) in the instrument cluster goes out.

**!** If you hear a warning signal, the red indicator lamp **PARK** (USA only) or **(P)** (Canada only) in the instrument cluster flashes and the message **Release Parking Brake** appears in the multifunction display when driving off, you have forgotten to release the parking brake.

Release the parking brake.

**i** At vehicle speeds of approximately 9 mph (15 km/h), the automatic central locking system engages and the locking knobs in the doors drop down.

The automatic door lock feature can be deactivated (▷ page 173).

You can open a locked door from the inside. Open door only when conditions are safe to do so.

**!** Simultaneously depressing the accelerator pedal and applying the brakes reduces engine performance and causes premature brake and drivetrain wear.

**!** Do not run a cold engine at high engine speeds as this may shorten its service life.

### Manual transmission

▶ Fully depress the clutch pedal.

**!** In order to avoid damage to the transmission, place the gearshift lever to reverse gear only when the vehicle is stopped.

▶ Move gearshift lever to first gear to drive forward, or to reverse gear to drive in reverse.

▶ Release the brake pedal.

▶ Simultaneously slowly release the clutch pedal and carefully depress the accelerator pedal.

**!** Shift gear in a timely manner and do not exceed the maximum permissible engine speed for each gear.

Do not allow the wheels to spin as this could damage the drive train.

## Automatic transmission\*

**Warning!**

It is dangerous to shift the gear selector lever out of **P** or **N** if the engine speed is higher than idle speed. If your foot is not firmly on the brake pedal, the vehicle could accelerate quickly forward or in reverse. You could lose control of the vehicle and hit someone or something. Only shift into gear when the engine is idling normally and when your right foot is firmly on the brake pedal.

**i** *Shifting from gear position **P** to position **R**, **N**, or **D** is only possible with the brake pedal depressed. Without the brake pedal depressed, the gear selector lever can be moved, but the parking pawl remains engaged, not allowing shifting to occur.*

- ▶ Depress the brake pedal.

The gear selector lever can now be used.

- ▶ Release the parking brake by pulling on release handle ①.

The indicator lamp **BRAKE** (USA only) or **(P)** (Canada only) in the instrument cluster goes out.

- ▶ Shift automatic transmission to **D** or **R**.

**i** *Wait for the gear selection process to complete before setting the vehicle in motion.*

**!** *Shift the automatic transmission to **P** or **R** only when the vehicle is stopped in order to avoid damaging the transmission.*

- ▶ Release the brake pedal.
- ▶ Carefully depress the accelerator pedal.

After a cold start, the automatic transmission shifts at a higher engine revolution. This allows the catalytic converter to reach its operating temperature earlier.

For more information, see “Driving instructions” (▷ page 311).

## Turn signals



## Combination switch

- ① Turn signals, right
- ② Turn signals, left

- ▶ Press the combination switch in the direction of arrow ① or ②.

The corresponding turn signal indicator lamp **↔** or **↔** in the instrument cluster flashes (▷ page 26).

The combination switch resets automatically after major steering wheel movements.

### Driving and parking

**i** To signal minor directional changes such as changing lanes, press combination switch only to point of resistance and release. The corresponding turn signals will flash three times.

#### Problems while driving

##### The engine runs erratically and misfires

- An ignition cable may be damaged.
- The engine electronics may not be operating properly.
- Unburned gasoline may have entered the catalytic converter and damaged it.
- ▶ Give very little gas.
- ▶ Have the problem repaired at an authorized Mercedes-Benz Center as soon as possible.

##### The coolant temperature is above 248°F (120°C)

The coolant is too hot and is no longer cooling the engine.

- ▶ Stop the vehicle in a safe location as soon as possible and turn off the engine. Allow engine and coolant to cool off.
- ▶ Check the coolant level and add coolant if necessary (▷ page 329).

**i** Excessive coolant temperatures trigger a warning message in the multifunction display (▷ page 402).

##### In case of accident

If the vehicle is leaking gasoline:

- ▶ Do not start the engine under any circumstances.
- ▶ Move away from vehicle.
- ▶ Notify local fire and/or police authorities.

If the extent of the damage cannot be determined:

- ▶ Notify an authorized Mercedes-Benz Center.

If no damage can be determined on the

- major assemblies
- fuel system
- engine mount:
- ▶ Start the engine in the usual manner.

## Parking

### Warning!



With the engine not running, there is no power assistance for the brake and the steering systems. In this case, it is important to keep in mind that a considerably higher degree of effort is necessary to brake and steer the vehicle.

### Warning!



Do not park this vehicle in areas where combustible materials such as grass, hay, or leaves can come into contact with the hot exhaust system, as these materials could be ignited and cause a vehicle fire.

To reduce the risk of personal injury as a result of vehicle movement, before turning off the engine and leaving the vehicle always:

- Keep right foot on brake pedal.

- Manual transmission: Move the gear-shift lever into neutral position (no gear is selected).
- Firmly depress parking brake pedal.
- Manual transmission: Move the gear-shift lever into first or reverse gear.
- Automatic transmission\*: Move the gear selector lever to position **P**.
- Slowly release brake pedal.
- When parked on an incline, turn front wheels towards the road curb.
- Turn the SmartKey to starter switch position **0** and remove, or press KEYLESS-GO\* start/stop button (▷ page 84).
- Take the SmartKey or the SmartKey with KEYLESS-GO\* with you and lock vehicle when leaving.

### Warning!



Engaging the parking brake while the vehicle is in motion can cause the rear wheels to lock up. You could lose control of the vehicle and cause an accident. In addition, the vehicle's brake lights do not light up when the parking brake is engaged.

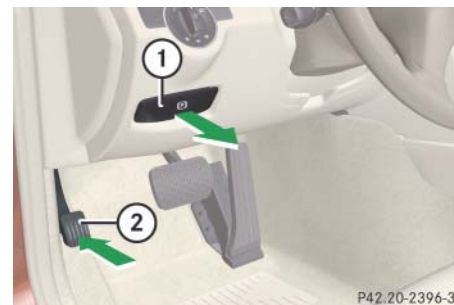

- ① Release handle
- ② Parking brake pedal



### Driving and parking

- ▷▷ Step firmly on parking brake pedal ②.

When the engine is running, the warning lamp **BRAKE** (USA only) or  (Canada only) in the instrument cluster will be illuminated.

#### Warning!



When leaving the vehicle, always remove the SmartKey or SmartKey with KEYLESS-GO\* (Canada only) from the starter switch, take it with you, and lock the vehicle. Do not leave children unattended in the vehicle, or with access to an unlocked vehicle. Children could release the parking brake and/or move the gear selector lever from position **P**, either of which could result in an accident and/or serious personal injury.

Position **P** alone may not prevent your vehicle from moving, possibly hitting people or objects. Always set the parking brake in addition to shifting to position **P** (▷ page 140) (manual transmission: first or reverse gear (▷ page 126).

When parked on an incline, always turn the front wheels towards the road curb.

Getting out of your vehicle without taking the above measurements to secure it is dangerous.

### Turning off the engine

- ▶ Manual transmission: Move the gear-shift lever into first or reverse gear.
- ▶ Automatic transmission\*: Place the gear selector lever in position **P**.

**i** *Vehicles with automatic transmission\*: You can switch off the engine with the selector lever in position **N**. However, to secure the vehicle, you need to set the selector lever to **P** and apply the parking brake.*

*The SmartKey can only be removed from the starter switch with the gear selector lever in position **P**.*

**i** *Always set the parking brake in addition to shifting to position **P** (manual transmission: first or reverse gear).*

*On slopes, turn the front wheels towards the road curb.*

**Warning!**

Do not turn off the engine before the vehicle has come to a complete stop. With the engine not running, there is no power assistance for the brake and steering systems. In this case, it is important to keep in mind that a considerably higher degree of effort is necessary to brake and steer the vehicle.

**SmartKey**

- ▶ **Turning off:** Turn the SmartKey in the starter switch to position **0** and remove it.  
The immobilizer is activated.

**KEYLESS-GO\* (Canada only)**

- ▶ **Turning off:** Press the KEYLESS-GO start/stop button to turn off the engine.

With the driver's door closed, the starter switch is now in position **1**. With the driver's door opened, the starter switch is set to position **0**, same as SmartKey removed from starter switch.

**i** In an emergency you can turn off the engine while driving by pressing and holding the KEYLESS-GO start/ stop button for approximately 3 seconds.

**Releasing seat belts**

- ▶ Press the seat belt release button (▷ page 106).

Allow the retractor to completely rewind the seat belt by guiding the latch plate.

**!** Make sure the seat belt retracts fully so that the seat belt and/or latch plate cannot get caught or pinched in the door or in the seat mechanism. This can damage the seat belt and impair the effectiveness of the seat belt, and/or cause damage to the door and/or door trim panel. Such damage is not covered by the Mercedes-Benz Limited Warranty.

Damaged seat belts must be replaced. Contact an authorized Mercedes-Benz Center.



### Manual transmission

Manual transmission is standard equipment on C 300 Sport and not available on other models.

For information on driving with a manual transmission, see “Manual transmission” (▷ page 130).

#### Warning!



For vehicles equipped with a manual transmission, getting out of your vehicle with the gearshift lever not engaged in first or reverse gear and parking brake engaged is dangerous.

Also, when parked on an incline, an engaged first or reverse gear alone may not prevent your vehicle from moving, possibly hitting people or objects.

Always set the parking brake in addition to engaging first or reverse gear (▷ page 134).

When parked on an incline, turn front wheels towards the road curb.

Do not park this vehicle in areas where combustible materials such as grass, hay or leaves can come into contact with the hot exhaust system, as these materials could be ignited and cause a vehicle fire.

#### Warning!



When leaving the vehicle, always remove the SmartKey from the starter switch, take it with you, and lock the vehicle. Do not leave children unattended in the vehicle, or with access to an unlocked vehicle. Children could move the gearshift lever, which could result in an accident and/or serious personal injury.

#### Warning!



On slippery road surfaces, never downshift in order to obtain braking action. This could result in drive wheel slip and reduced vehicle control. Your vehicle's ABS will not prevent this type of loss of control.

#### Warning!



Make sure absolutely no objects are obstructing the pedals' range of movement. Keep the driver's footwell clear of all obstacles. If there are any floor mats or carpets in the footwell, make sure the pedals still have sufficient clearance.

During sudden driving or braking maneuvers the objects could get caught between or beneath the pedals. You could then no longer brake or accelerate. This could lead to accidents and injury.

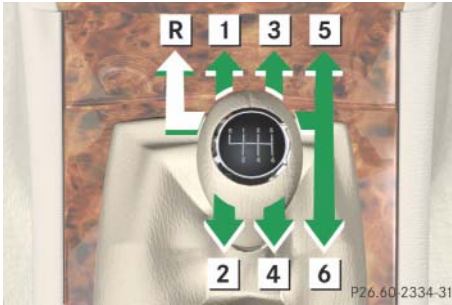

**Gearshift pattern for manual transmission**

**!** When you are shifting into the **5th** or **6th** gear, make sure you press the gearshift lever to the right. Otherwise, you could accidentally shift into the **3rd** or **4th** gear and damage the transmission.

Downshifting gears leading to overrevving the engine can result in engine damage that is not covered by the Mercedes-Benz Limited Warranty.

Never hold the vehicle stopped on a hill by using the clutch pedal. The clutch may be damaged which is not covered by the Mercedes-Benz Limited Warranty.

Do not exceed the engine speed limits. Refer to tachometer (▷ page 149) for engine speeds.

### Shifting into reverse

**!** Only shift into reverse gear **R** when the vehicle is stationary, as the transmission could otherwise be damaged.

- ▶ Stop the vehicle completely.
- ▶ Fully depress clutch pedal.
- ▶ Move the gearshift lever to neutral position (no gear selected).
- ▶ Move the gearshift lever to the left until you feel a certain resistance.
- ▶ Push the gearshift lever past this resistance.
- ▶ Then move the gearshift lever forward into position **R**.

### Automatic transmission\*

For more information on driving with an automatic transmission, see “Automatic transmission\*” (▷ page 131).

Your vehicle’s transmission adapts its gear shifting process to your individual driving style by continually adjusting the shift points up or down. These shift point adjustments are performed based on current operating and driving conditions.

If the operating conditions change, the automatic transmission reacts by adjusting its shift program.

**i** *During the brief warm-up, transmission upshifting is delayed. This allows the catalytic converter to heat up more quickly to operating temperature.*

#### Warning!



Make sure absolutely no objects are obstructing the pedals’ range of movement. Keep the driver’s footwell clear of all obstacles. If there are any floor mats or carpets in the footwell, make sure the pedals still have sufficient clearance.

During sudden driving or braking maneuvers the objects could get caught between beneath the pedals. You could then no longer brake or accelerate. This could lead to accidents and injury.

### Gear selector lever

The gear selector lever is located on the lower part of the center console.



#### Gearshift pattern for automatic transmission

- P** Park position
- R** Reverse gear
- N** Neutral
- D** Drive position

**i** *The current gear selector lever position **P**, **R**, **N** or **D** appears in the multifunction display (▷ page 140).*

**Warning!**

It is dangerous to shift the gear selector lever out of park position **P** or neutral position **N** if the engine speed is higher than idle speed. If your foot is not firmly on the brake pedal, the vehicle could accelerate quickly forward or reverse. You could lose control of the vehicle and hit someone or something. Only shift into gear when the engine is idling normally and when your right foot is firmly on the brake pedal.

An additional indication of the current gear selector lever position can be found on the cover of the shifting-gate.

The indicators come on when you activate a switch (e.g. unlocking the vehicle or opening a door) and go out after approximately 15 minutes.

**Shifting procedure**

The automatic transmission selects individual gears automatically, depending on:

- gear selector lever position **D** (▷ page 140) with gear ranges (▷ page 143)
- the selected program mode (**C/S**) (▷ page 144)
- the position of the accelerator pedal (▷ page 142)
- the vehicle speed

**!** Allow engine to warm up under low load use. Do not place full load on the engine until the operating temperature has been reached.

Shift into reverse gear **R** or park position **P** only when the vehicle is stopped.

Avoid spinning of a drive wheel when driving off on slippery road surfaces. This may cause serious damage to the drivetrain which is not covered by the Mercedes-Benz Limited Warranty.

When the gear selector lever is in drive position **D**, you can influence transmission shifting by:

- limiting the gear range
- changing gears manually

## Automatic transmission\*

### Gear selector lever positions

The current gear selector lever position appears in the multifunction display.



① Current gear selector lever position

### Effect

#### **P** Park position

Gear selector lever position when the vehicle is parked. Place gear selector lever in park position **P** only when vehicle is stopped. The park position is not intended to serve as a brake when the vehicle is parked. Rather, the driver should always set the parking brake in addition to placing the gear selector lever in park position **P** to secure the vehicle.

### Effect

The SmartKey can only be removed from the starter switch with the gear selector lever in park position **P**. With the SmartKey removed, the gear selector lever is locked in park position **P**.

If the vehicle's electrical system is malfunctioning, the gear selector lever could remain locked in park position **P** (▷ page 426).

#### **R** Reverse gear

Place gear selector lever in position **R** only when vehicle is stopped.

	Effect
<b>N</b>	<p><b>Neutral</b></p> <p>No power is transmitted from the engine to the drive axle. When the brakes are released, the vehicle can be moved freely (pushed or towed).</p> <p>To avoid damage to the transmission, never engage neutral position <b>N</b> while driving.</p> <p>If the ESP® is deactivated or malfunctioning: Move gear selector lever to neutral position <b>N</b> only if the vehicle is in danger of skidding, e.g. on icy roads.</p>
<b>D</b>	<p><b>Drive</b></p> <p>The transmission shifts automatically. All forward gears are available.</p>

**!** *Coasting the vehicle, or driving for any other reason with gear selector lever in neutral position **N** can result in transmission damage that is not covered by the Mercedes-Benz Limited Warranty.*

**Warning!**



Getting out of your vehicle without shifting into park position **P** is dangerous. Also, park position **P** alone is not intended to or capable of preventing your vehicle from moving, possibly hitting people or objects.

Always set the parking brake (> page 140) in addition to shifting to park position **P**.

When parked on an incline, turn the front wheels towards the road curb.

Do not park this vehicle in areas where combustible materials such as grass, hay or leaves can come into contact with the hot exhaust system, as these materials could be ignited and cause a vehicle fire.

**Warning!**



When leaving the vehicle, always remove the SmartKey or SmartKey with KEYLESS-GO\* (Canada only) from the starter switch, take it with you, and lock the vehicle. Do not leave children unattended in the vehicle, or with access to an unlocked vehicle. Children could move the gear selector lever from park position **P**, which could result in an accident and/or serious personal injury.

Getting out of your vehicle without taking the above measurements to secure it is dangerous.

### Automatic transmission\*

#### Driving tips

---

##### Accelerator position

Your driving style influences the transmission's shifting behavior:

Less throttle	Earlier upshifting
More throttle	Later upshifting

##### Kickdown

Use kickdown when you want maximum acceleration.

- ▶ Press the accelerator past the point of resistance.  
Depending on the engine speed the transmission shifts into a lower gear.
- ▶ Ease on the accelerator when you have reached the desired speed.  
The transmission shifts up again.

#### Stopping

When you stop briefly, e.g. at traffic lights:

- ▶ Leave the transmission in gear.
- ▶ Hold the vehicle with the brake.

When you stop for a longer period of time with the engine idling and/or on a hill:

- ▶ Set the parking brake.
- ▶ Move the gear selector lever to park position **P**.

#### Maneuvering

When you maneuver in tight areas, e.g. when pulling into a parking space:

- ▶ Control the vehicle speed by gradually releasing the brakes.
- ▶ Accelerate gently.
- ▶ Never abruptly step on the accelerator.

#### Working on the vehicle

##### Warning!



When working on the vehicle, set the parking brake and move gear selector lever to park position **P**. Otherwise the vehicle could roll away.

**Gear ranges**

With the gear selector lever in drive position **D**, you can select a gear range for the automatic transmission to operate within.

Gear selector lever (▷ page 145):

You can limit the gear range by pressing the gear selector lever to the left (**D-**), and reverse the gear range limit by pressing the gear selector lever to the right (**D+**).

The selected gear range appears in the multifunction display.



① Current gear range

Effect	
<b>6</b>	The transmission shifts through sixth gear only.
<b>5</b>	The transmission shifts through fifth gear only.
<b>4</b>	The transmission shifts through fourth gear only.

Effect	
<b>3</b>	The transmission shifts through third gear only.  With this selection you can use the braking effect of the engine.
<b>2</b>	The transmission shifts through second gear only.  Allows the use of engine's braking power when driving <ul style="list-style-type: none"> <li>• on steep downgrades</li> <li>• in mountainous regions</li> <li>• under extreme operating conditions</li> </ul>
<b>1</b>	The transmission operates in first gear only.  For maximum use of engine's braking effect on very steep or lengthy downgrades.



## Automatic transmission\*

### Automatic shift program

The program mode selector switch is located on the lower part of the center console.

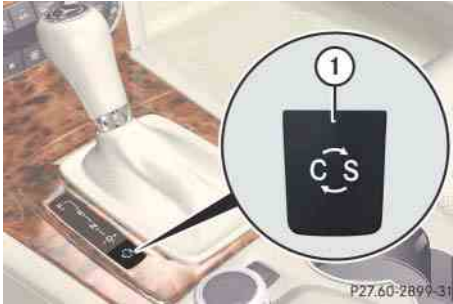

#### Program mode selector switch

- C** Comfort For comfort driving
- S** Sport For standard driving

The selected program mode appears in the multifunction display.



① Selected program mode (comfort or sport)

**!** Never change the program mode when the gear selector lever is out of park position **P**. This could result in a change of driving characteristics for which you may not be prepared.

**i** The last selected program mode (**C** or **S**) is switched on when the engine is restarted.

► Press program mode selector switch repeatedly until the letter of the desired program mode appears in the multifunction display.

Select **C** for comfort driving:

- The vehicle starts out in second gear (both forward and reverse) for gentler starts. This does not apply if full throttle is applied or gear range **1** is selected.
- Traction and driving stability are improved on icy roads.
- Upshifts occur earlier even when you give more gas. The engine then operates at lower rpms and the wheels are less likely to spin.

Select **S** for standard driving:

- The vehicle starts out in first gear.
- Upshifts occur later.

## Gear selector lever one-touch gearshifting

With the gear selector lever in drive position **D**, you can limit or extend the gear range.

**!** Allow engine to warm up under low load use. Do not place full load on the engine until the operating temperature has been reached.

Shift into reverse gear **R** or park position **P** only when the vehicle is stopped.

Avoid spinning of a drive wheel when driving off on slippery road surfaces. This may cause serious damage to the drivetrain which is not covered by the Mercedes-Benz Limited Warranty.

## Limiting gear range

### Warning!



On slippery road surfaces, never downshift in order to obtain braking action. This could result in drive wheel slip and reduced vehicle control. Your vehicle's ABS will not prevent this type of loss of control.

- ▶ Briefly press the gear selector lever to the left in the **D-** direction.

The transmission will shift to the next lower gear as permitted by the shift program. This action simultaneously limits the gear range of the transmission (> page 143).

- i** To avoid overrevving the engine when downshifting, the transmission will not shift to a lower gear if the engine's max. speed would be exceeded.

## Extending gear range

- ▶ Briefly press the gear selector lever to the right in the **D+** direction.

The transmission will shift to the next higher gear as permitted by the shift program. This action simultaneously extends the gear range of the transmission.

- i** If you press on the accelerator when the engine has reached its rpm limit, the transmission will upshift beyond any gear range limit selected.

## Canceling gear range limit

- ▶ Press and hold the gear selector lever in the **D+** direction until **D** reappears in the multifunction display (> page 140).

The transmission will shift from the current gear range directly to gear range **D**.

## Shifting into optimal gear range

- ▶ Press and hold the gear selector lever in the **D-** direction.

The transmission will automatically select the gear range suited for optimal acceleration and deceleration. This will involve shifting down one or more gears.

### Automatic transmission\*

#### Emergency operation (Limp-Home Mode)

---

If vehicle acceleration becomes less responsive or sluggish or the transmission no longer shifts, the transmission is most likely operating in limp-home (emergency operation) mode. In this mode only second gear and reverse gear can be selected.

- ▶ Stop the vehicle in a safe location.
- ▶ Move the gear selector lever to park position **P**.
- ▶ Turn off the engine.
- ▶ Wait at least 10 seconds before restarting.
- ▶ Restart the engine.
- ▶ Move the gear selector lever to position **D** (for second gear) or position **R**.
- ▶ Have the transmission checked at an authorized Mercedes-Benz Center as soon as possible.

## ▼ Instrument cluster

### Warning!



No messages will be displayed if either the instrument cluster or the multifunction display is inoperative.

As a result, you will not be able to see information about your driving conditions, such as speed or outside temperature, warning/indicator lamps, malfunction/warning messages or the failure of any systems. Driving characteristics may be impaired.

If you must continue to drive, please do so with added caution. Contact an authorized Mercedes-Benz Center as soon as possible.

A full view illustration of the instrument cluster can be found in the “At a glance” section of this manual (▷ page 26).

You can change the instrument cluster settings in the instrument cluster submenu of the control system (▷ page 168).

### Multifunction display

---

The multifunction display is activated when you:

- open a door
- switch on the ignition
- switch on the exterior lamps

The language setting for the multifunction display can be changed via control system (▷ page 168).

## Instrument cluster

### Adjusting instrument cluster display illumination

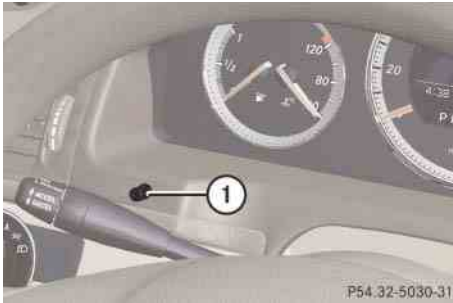

① Dimmer

**i** The instrument cluster illumination is dimmed or brightened automatically to suit ambient light conditions.

The instrument cluster illumination will also be adjusted automatically when you switch on the vehicle's exterior lamps.

- ▶ **Brightening illumination:** Turn dimmer ① clockwise.
- ▶ **Dimming illumination:** Turn dimmer ① counterclockwise.

### Coolant temperature gauge

The coolant temperature gauge is on the left side in the instrument cluster (▷ page 26).

#### Warning!



- Driving when your engine is overheated can cause some fluids which may have leaked into the engine compartment to catch fire. You could be seriously burned.
- Steam from an overheated engine can cause serious burns and can occur just by opening the hood. Stay away from the engine if you see or hear steam coming from it.

Stop the vehicle in a safe location away from other traffic. Turn off the engine, get out of the vehicle and do not stand near the vehicle until the engine has cooled down.

**!** Excessive coolant temperature triggers a warning in the multifunction display (▷ page 402).

*The engine should not be operated with the coolant temperature above 248°F (120°C), i.e. in the red zone of the coolant temperature gauge. Doing so may cause serious engine damage which is not covered by the Mercedes-Benz Limited Warranty.*

**i** During severe operating conditions, e.g. stop-and-go traffic, the coolant temperature may rise close to 248°F (120°C), i.e. close to the red zone of the temperature gauge.

## Tachometer

The red marking on the tachometer denotes excessive engine speed.

**!** Avoid driving at excessive engine speeds, as it may result in serious engine damage that is not covered by the Mercedes-Benz Limited Warranty.

To help protect the engine, the fuel supply is interrupted if the engine is operated within the red marking.

## Outside temperature indicator

The outside temperature is indicated in the multifunction display (▷ page 151).

### Warning!



The outside temperature indicator is not designed to serve as an ice-warning device and is therefore unsuitable for that purpose.

Indicated temperatures just above the freezing point do not guarantee that the road surface is free of ice. The road may still be icy, especially in wooded areas or on bridges.

The outside temperature sensor is located in the front bumper area. Due to its location, the sensor can be affected by road or engine heat during idling or slow driving. Therefore, the accuracy of the displayed temperature can only be verified by comparison to a thermometer placed next to the sensor, not by comparison to external displays (e.g. bank signs, etc.).

When moving the vehicle into colder ambient temperatures (e.g. when leaving your garage), you will notice a delay before the lower temperature is displayed.

A delay also occurs when ambient temperatures rise. This prevents inaccurate temperature indications caused by heat radiated from the engine during idling or slow driving.

#### Fuel gauge

---

The fuel gauge is on the left-hand side of the instrument cluster (▷ page 26). Once the fuel level has fallen below the reserve mark, the yellow fuel tank reserve warning lamp  for the fuel reserve comes on (▷ page 380).

## ▼ Control system

The control system is activated as soon as the SmartKey in the starter switch is turned to position **2** or as soon as the KEYLESS-GO\* start/stop button (Canada only) is in position **2**. The control system enables you to:

- call up information about your vehicle
- change vehicle settings

For example, you can use the control system to find out when your vehicle is next due for service, to call up statistical data on your vehicle, and much more.

### Warning!



A driver's attention to the road and traffic conditions must always be his/her primary focus when driving.

For your safety and the safety of others, selecting features through the multifunction steering wheel should only be done by the driver when traffic and road conditions permit it to be done safely.

Bear in mind that at a speed of just 30 mph (approximately 50 km/h), your vehicle is covering a distance of 44 feet (approximately 14 m) every second.

The control system relays information to the multifunction display.

## Multifunction display



- ① Text field
- ② Line for main menus
- ③ Temperature
- ④ Current program mode (automatic transmission\*)
- ⑤ Current gear selector lever position/gear range (automatic transmission\*)  
Additional speedometer (manual transmission)
- ⑥ Digital clock

Settings, functions, submenus as well as any malfunctions are shown to you in the text field.



## Control system

### Multifunction steering wheel

The displays in the multifunction display and the settings in the control system are controlled using the buttons on the multifunction steering wheel.



Item
① Multifunction display
<b>Operating control system</b>
② Volume control: Press button
to increase volume
to decrease volume
Telephone*: Press button
to take a call to dial a call
to end a call to reject an incoming call
to mute
③  to activate Voice Control*

Item
④  to cancel Voice Control*, back, confirm messages
⑤ To call up line for menus and select menus: Press button
to scroll to the right
to scroll to the left
To select submenu or scroll through lists: Press button
to scroll up
to scroll down
Press button
to confirm selection or messages

**i** Voice Control\* is only available with COMAND\*. Refer to separate operating instructions.

Depending on the selected menu (▷ page 155), pressing the buttons on the multifunction steering wheel will alter what is shown in the multifunction display.

The information available in the multifunction display is arranged in menus, each containing a number of functions or sub-menus.

The individual functions are then found within the relevant menu (radio or CD operations under *Audio*, for example). These functions serve to call up relevant information or to customize the settings for your vehicle.

In the *Settings* menu, instead of functions you will find a number of submenus for calling up and changing settings. For instructions on using these submenus, see “Submenus in the Settings menu” (▷ page 166).







It is helpful to think of the menus, and the functions within each menu, as being arranged in a circular pattern.

The number of menus available in the system depends on which optional equipment is installed in your vehicle.

**i** *The headings used in the menu table are designed to facilitate navigation within the system and are not necessarily identical to those shown in the control system displays.*

*The first function displayed in each menu will automatically show you which part of the system you are in.*

### Using the control system

- ▶ **To select a menu:**  
Press button  or .
- ▶ **To select a submenu:**  
Press button  or .
- ▶ **To go to the next higher menu level:**  
Press button .
- ▶ **To select the standard display:** Press button  repeatedly until the standard display featuring the odometer and speedometer appears.

or

- ▶ Press and hold button  until the standard display featuring the odometer and speedometer appears.

- ▶ **To confirm selection:**

Press button .

- ▶ **To confirm display message:**

Press button  or .

The control system saves certain display messages. Calling up display messages (▷ page 164).

For information about warning and malfunction messages appearing in the multifunction display (▷ page 387).

### Menus

This is what you will see when you scroll through the menus.

The table on the next page provides an overview of the individual menus.

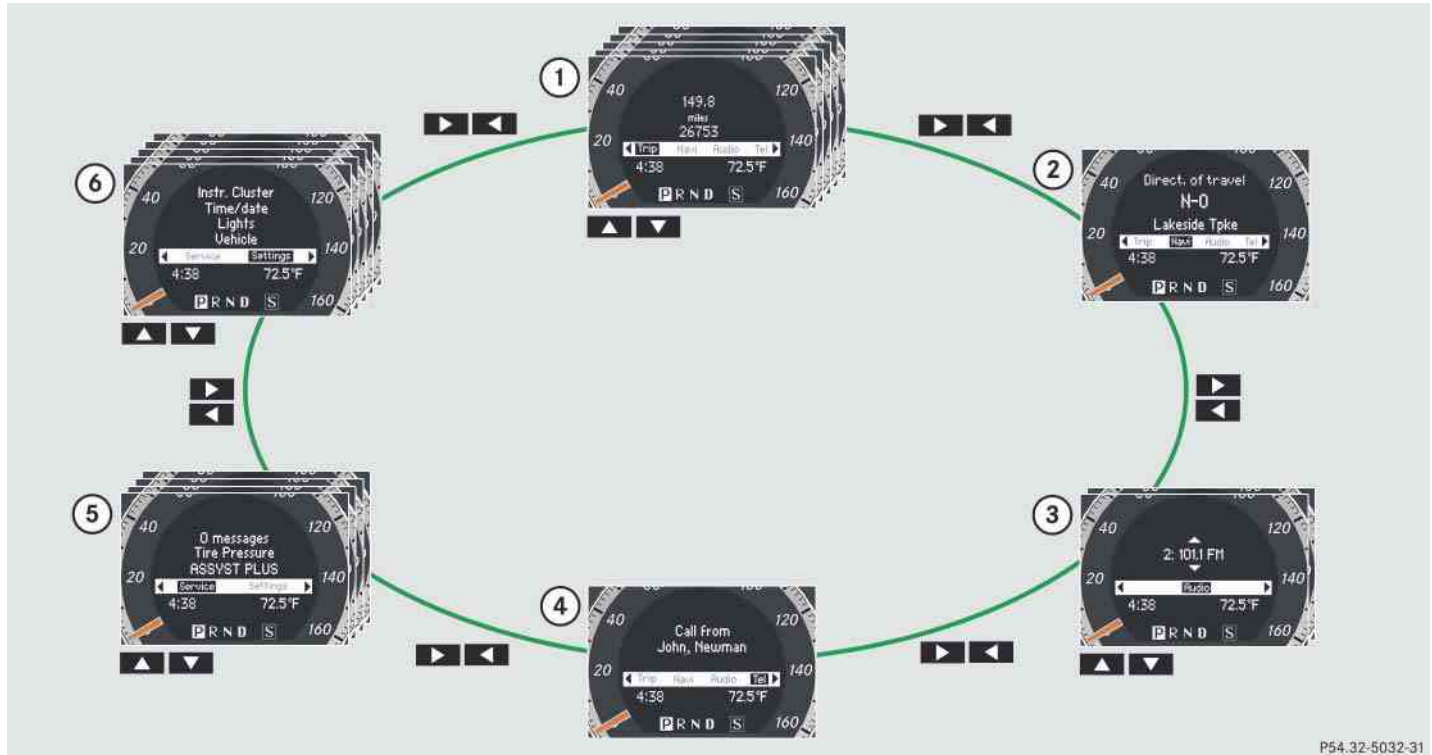

P54.32-5032-31

Menus, submenus and functions

	Menu ①	Menu ②	Menu ③	Menu ④	Menu ⑤	Menu ⑥
	<b>Trip computer</b> (▷ page 156)	<b>Navi*</b> (▷ page 158)	<b>Audio</b> (▷ page 158)	<b>Tel*</b> (▷ page 160)	<b>Service</b> (▷ page 164)	<b>Settings</b> (▷ page 165)
<b>Commands/submenus</b>	Standard display	Show route guidance instructions, current direction traveled	Selecting radio station	To take a call	Call up vehicle malfunction, warning and system status messages stored in memory <sup>1</sup>	Reset to factory settings
	Fuel consumption statistics since start		Selecting satellite radio station*	Select a phone book entry	Tire Pressure Monitoring System (TPMS) (USA only)	Instrument cluster submenu
	Fuel consumption statistics since the last reset		Operating CD player*	Redial	Run Flat Indicator (Canada only)	
	Distance to empty				Call up maintenance service display	
	Digital speedometer or outside temperature					

<sup>1</sup> The vehicle status message memory menu is only displayed if there is a message stored.

## Control system

### Trip menu

In the Trip menu, you can show an additional display for the speedometer and call up or reset your vehicle's statistical data.

The following information is available:

Function	Page
Standard display	156
Fuel consumption statistics since start	156
Fuel consumption statistics since last reset	157
Distance to empty	157
Digital speedometer	158
Resetting	157

### Standard display

In the standard display, the trip odometer and the main odometer are shown in the multifunction display.



- ① Trip odometer
- ② Main odometer

If another display is shown instead of the standard display:

- ▶ Press or to select the Trip menu.

or

- ▶ Press button repeatedly until the standard display appears.

or

- ▶ Press and hold button until the standard display appears.

### Fuel consumption statistics since start

- ▶ Press or to select the Trip menu.

- ▶ Press to select From Start.



- ① Distance driven since start
- ② Time elapsed since start
- ③ Average speed since start
- ④ Average fuel consumption since start

**i** All values that are based on the last start are reset when you turn off the vehicle's engine for more than four hours.

*If you turn the SmartKey to position 1 or 2 again during this time, the values will not be reset.*

*After 999 hours or 9999 miles (kilometers), the fuel consumption statistics after start are automatically reset.*

### Fuel consumption statistics since last reset

- ▶ Press **◀** or **▶** to select the Trip menu.
- ▶ Press **▼** or **▲** to select Since Reset.



- ① Distance driven since last reset
- ② Time elapsed since last reset
- ③ Average speed since last reset
- ④ Average fuel consumption since last reset

**i** After 9999 hours or 99999 miles (kilometers), the fuel consumption statistics since last reset are automatically reset.

### Resetting values

You can reset the values for the following functions:

- Trip odometer
  - Fuel consumption statistics since start
  - Fuel consumption statistics since last reset
- ▶ Press **◀** or **▶** to select the Trip menu.
  - ▶ Press **▼** or **▲** to select the function you wish to reset.
  - ▶ Press **OK**.



### Example illustration: Reset fuel consumption statistics since start

- ▶ Press **▼** to select Yes.
- ▶ Press **OK** to confirm.

### Distance to empty

- ▶ Press **◀** or **▶** to select the Trip menu.
- ▶ Press **▼** or **▲** to select Range.

With the ignition switched on, the calculated remaining driving range based on the current fuel tank level appears in the multifunction display.



- ① Approximate distance

When the reserve tank is half empty, only the fuel pump symbol **⛽** is displayed.

## Control system

### Digital speedometer

- ▶ Press **◀** or **▶** to select the Trip menu.
- ▶ Press **▼** or **▲** to select the digital speedometer.



① Digital speedometer

### Navi\* menu

The Navi menu contains the functions needed to operate your navigation system.

- ▶ Press **◀** or **▶** to select the Navi menu.
- If COMAND\* is switched off, the message **Navi Off** appears in the multifunction display.
- With COMAND\* switched on but route guidance not activated, the direction of travel and, if available, the name of the street currently traveled on appear in the multifunction display.
- With COMAND\* switched on and route guidance activated, the direction of travel and maneuver instructions appear in the multifunction display.

Please refer to the COMAND\* manual for instructions on how to activate the route guidance system\*.

### Audio menu

The functions in the Audio menu operate the audio equipment which you currently have turned on.

If no audio equipment is currently turned on, the message **Audio Off** appears in the multifunction display.

The following functions are available:

Function	Page
Selecting radio station	159
Selecting satellite radio station*	159
Operating CD player*	160

- ▶ **To adjust the volume:** Press **+** or **-** on the multifunction steering wheel.

### Selecting radio station

- ▶ Turn on the audio system (▷ page 188) and press button **RADIO** on audio control unit.  
Vehicles with COMAND\*: Refer to separate operating instructions.
- ▶ Press **◀** or **▶** to select the Audio menu. The currently tuned station appears in the multifunction display.

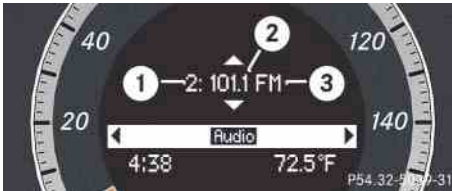

- ① Waveband setting
- ② Station frequency

- ▶ **Select next or previous stored station:** Press **▼** or **▲** briefly to select a stored station.
- ▶ **Select next or previous station in waveband:** Press and hold **▼** or **▲** to select a station.

**i** You can only store new stations using the corresponding feature on the radio (▷ page 198).

Vehicles with COMAND\*:  
Refer to separate operating instructions.

You can also operate the radio in the usual manner.

### Selecting satellite radio station\*

The satellite radio is treated as a radio application.

- ▶ Turn on the radio (▷ page 188) and select the satellite radio with the audio control unit.  
Vehicles with COMAND\*: Refer to separate operating instructions.
- ▶ Press **◀** or **▶** to select the Audio menu. The currently tuned channel appears in the multifunction display.



- ① SAT mode
- ② Channel name and/or number

- ▶ **Select next or previous stored channel:** Press **▼** or **▲** briefly to select a stored channel.
- ▶ **Select next or previous channel in waveband:** Press and hold **▼** or **▲** to select a channel.

**i** A subscription to SIRIUS Satellite Radio service provider is required for the satellite radio operation. Contact an authorized Mercedes-Benz Center for details and availability for your vehicle.

For more information on satellite radio operation, see "Satellite radio\*" (▷ page 200).

Vehicles with COMAND\*:  
Refer to separate operating instructions.



## Control system

### Operating the CD player\*

- ▶ Turn on the radio and select the CD mode (▷ page 213).

Vehicles with COMAND\*:

Refer to separate operating instructions.

- ▶ Press **◀** or **▶** to select the Audio menu. The settings for the currently being played CD appear in the multifunction display.



- ① Current CD (with additional number from 1 to 6 when running from CD changer\*)

- ② Current track

- ▶ Press **▼** or **▲** to select a track.

**i** To select a CD from the CD changer\* magazine, press a number on the audio system or the COMAND\* system key pad located in the center console.

For more information on CD operation, see “CD mode” (▷ page 208) and for the CD changer\*, see (▷ page 214).



- ① Current track

**i** Level of information displayed will vary depending on the information contained on the CD with MP3 files insert in the audio or COMAND\* system.

For more information on MP3, see “Notes about MP3 mode” (▷ page 210).

### TEL menu\*

You can use the functions in the Tel menu to operate your Bluetooth® enabled telephone, if it is switched on and connected via the Bluetooth® interface to the audio system.

Vehicles with COMAND\*: Refer to separate operating instructions.

### Warning!



Some jurisdictions prohibit the driver from using a cellular telephone while driving. Whether or not prohibited by law, for safety reasons, the driver should not use the cellular telephone while the vehicle is in motion. Stop the vehicle in a safe location before placing or answering a call.

If you nonetheless choose to use the mobile phone while driving, please use the hands-free device and be sure to pay attention to the traffic situation at all times. Use the mobile phone only when road, weather and traffic conditions permit.

Otherwise, you may not be able to observe traffic conditions and could endanger yourself and others.

Bear in mind that at a speed of just 30 mph (approximately 50 km/h), your vehicle is covering a distance of 44 feet (approximately 14 m) every second.

### Warning!



Never operate radio transmitters equipped with a built-in or attached antenna (i.e. without being connected to an external antenna) from inside the vehicle while the engine is running. Doing so could lead to a malfunction of the vehicle's electronic system, possibly resulting in an accident and personal injury.

- ▶ Switch on the telephone and audio system.
- ▶ Activate and register the telephone (▷ page 225).

- ▶ Press ◀ or ▶ to select the Tel menu.

Which messages will appear in the multifunction display depends on whether your telephone is switched on or off:

- If the Bluetooth® function on the audio system is disabled, the message Bluetooth not activated in system settings appears. To enable Bluetooth® (▷ page 193).
- If the telephone is switched on, the telephone will then search for a network. During this time, the message No Service appears in the multifunction display. If no network available, the multifunction display message No Service is shown continuously.
- If the telephone is on, as soon as the telephone has found a network, Phone Ready appears in the multifunction display.



This standby message indicates that your telephone is ready for use and you can operate it using the control system.

You may carry out the following functions:

Function	Page
Dialing a number from the phone book	162
Redialing	163
Answering a call	163
Ending a call or rejecting an incoming call	163

### Control system

#### Dialing a number from the phone book

**i** For using the phone book of the audio system you can import business cards (vCards) from external Bluetooth® phones into your audio system's phone book (▷ page 233).

If your telephone is ready to receive calls, you may select and dial a number from the phone book at any time.

- ▶ Press **◀** or **▶** to select the **Tel** menu.
- ▶ Log on to the network (▷ page 193).
- ▶ Press **▼** or **▲** or **OK** to switch to the phone book.

The stored names are displayed in ascending alphabetical order.

- ▶ Press **▼** or **▲** to select the desired name.

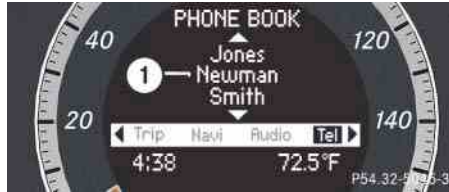

#### ① Name from the phone book

**i** If you press and hold **▼** or **▲** for more than 1 second, the system scrolls rapidly through the list of names.

If you press and hold **▼** or **▲** for more than 4 seconds, the control system shows the first four entries of the letter next used. Release the button to stop the quick search. The search stops automatically at the end of the list.

- ▶ Press **☎** or **OK** to start dialing.

If several entries are present for the same name, they are all shown.

- ▶ Press **▼** or **▲** to select the desired entry.
- ▶ Press **☎** or **OK** to start dialing.

The message **Connecting call...** appears on the multifunction display, as well as the dialed telephone number or name as long as it is stored in the phone book.

The dialed number is saved in the “Dialed numbers” list.





Once a connection has been established, the name appears on the multifunction display, provided that it has been stored in the phone book, otherwise the dialed telephone number appears.



**i** If you do not want to dial from the phone book, press **☎** or **☎**. The message **Ready again** appears in the multifunction display.

## Redialing

The control system stores ten of the last dialed phone numbers. This eliminates the need to search through your entire phone book.

- ▶ Log on to the network (▷ page 193).
- ▶ Press  to switch to the number and/or name last dialed in the redial memory.
- ▶ Press  or  to select the desired number and/or name.
- ▶ Press  or **OK** to start dialing.

Once a connection has been established, the name appears in the multi-function display, provided that it has been stored in the phone book, otherwise the dialed telephone number appears.

## Answering a call

When your telephone is ready to receive calls, you can answer a call at any time. When you are in the **Te1** menu, you will see the following message on the multifunction display:



- ▶ Press  to take the call.

**i** *The caller's number appears only if it is transmitted.*

*The caller's name appears only if the number and the name are stored in the phone book.*

## Ending a call or rejecting an incoming call

You can end a call or reject an incoming call at any time.

- ▶ Press  to end or reject a call.

### Control system

#### Service menu

---

The *Service* menu is used for

- calling up messages
- checking tire inflation pressure electronically with the TPMS (standard on U.S. vehicles)
- activating Run Flat Indicator (standard on Canada vehicles)
- calling up the maintenance service indicator display

#### Calling up vehicle malfunction, warning and system status messages stored in memory

Use the vehicle status message memory menu to scan malfunction and warning messages that may be stored in the system. Such messages appear in the multifunction display and are based on conditions or system status the vehicle's system has recorded.

The vehicle status message memory menu only appears if there are any messages stored.

#### Warning!



Malfunction and warning messages are only indicated for certain systems and are intentionally not very detailed. The malfunction and warning messages are simply a reminder with respect to the operation of certain systems and do not replace the owner's and/or driver's responsibility to maintain the vehicle's operating safety by having all required maintenance and safety checks performed on the vehicle and by bringing the vehicle to an authorized Mercedes-Benz Center to address the malfunction and warning messages (▷ page 387).

- ▶ Press **◀** or **▶** to select the Service menu.

If conditions have occurred causing status messages to be recorded, the number of messages appears in the multifunction display:

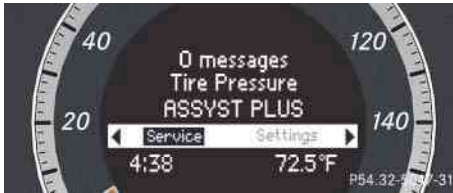

- ① Number of messages
- ▶ Press **▼** or **▲** to select the message.
- ▶ Press **OK** to confirm.  
The stored messages will now be displayed in the order in which they have occurred.
- ▶ Use **▼** or **▲** to scroll through the messages.

**i** See the “Practical hints” section for malfunction and warning messages (▷ page 387).

**i** If you turn the SmartKey in the starter switch to position **0** and then back to position **2**, all messages will be deleted from the message memory.

### Checking tire inflation pressure

For information about checking tire inflation pressure (▷ page 339).

### Activating Run Flat Indicator (Canada only)

For information about activating Run Flat Indicator (▷ page 342).

### Calling up the maintenance service indicator display

For information about calling up the maintenance service indicator display (▷ page 362).

## Settings menu

In the Settings menu there are two functions:

- The function **Reset to factory settings**, with which you can reset all the settings to the original factory settings.
- A collection of submenus with which you can make individual settings for your vehicle.

## Control system

### Resetting all settings

You can reset most of the functions of the submenus to the factory settings.

**i** For safety reasons, the following function are not reset while driving:

- the Headlamp mode function in the Lighting submenu
- ▶ Press **◀** or **▶** to select the Settings menu.
- ▶ Press **▼** or **▲** to select the Factory settings function.
- ▶ Press **OK**.

The menu Reset to factory settings No/Yes appears in the multifunction display.



- ▶ Press **▼** or **▲** to select Yes or No. Select Yes if you want to reset to factory settings.
- ▶ Press **OK** to confirm. The confirmation message appears in the multifunction display. The functions of the submenus will reset to factory settings.

### Submenus in the Settings menu

- ▶ Press **◀** or **▶** to select the Settings menu.



- ▶ Press **▼** or **▲** to select a submenu.

The submenus are arranged by hierarchy. Scroll down with **▼**, scroll up with **▲**.

With the selection marker on the desired submenu, use the **OK** to access the individual functions within that submenu. Once within the submenu, you can use the **▲** to move to the next function or the **▼** to move to the previous function within that submenu.

The table below shows what settings can be changed within the various submenus.

Detailed instructions on making individual settings can be found on the following pages.

<b>Instrument cluster</b> (▷ page 168)	<b>Time/Date</b> (▷ page 170)	<b>Lighting</b> (▷ page 171)	<b>Vehicle</b> (▷ page 173)	<b>Convenience</b> (▷ page 174)
Select speedometer display mode	Set the time (hours)	Setting daytime running lamp mode (USA only)	Set automatic locking	Activate easy-entry/exit feature* (Canada only)
Switch the additional speedometer on or off (vehicles with manual transmission)	Set the time (minutes)	Setting locator lighting		Setting fold-in function* for exterior rear view mirrors
Permanent display (vehicles with automatic transmission*)	Set the date (month)	Setting night security illumination		
	Set the date (day)	Setting interior lighting delayed shut-off		
	Set the date (year)			



### Control system

#### Instrument cluster submenu

Access the Instr. Cluster submenu via the Settings menu. Use the Instr. Cluster submenu to change the instrument cluster display settings.

The following functions are available:

Function	Page
Select speedometer display mode	168
Switch the additional speedometer on or off (vehicles with manual transmission)	169
Permanent display (vehicles with automatic transmission*)	169

#### Select speedometer display mode

- ▶ Press **▼** or **▲** to select the Instr. Cluster submenu.
- ▶ Press **OK**.
- ▶ Press **▼** or **▲** to select Display Unit Speed-/odometer function.

The selection marker is on the current setting.



- ▶ Press **▼** or **▲** to set speedometer unit to km or miles.
- ▶ Press **OK** to confirm the setting.

The selected display unit is valid for:

- Odometer and trip odometer
- Trip computer
- Digital speedometer in the trip menu
- Cruise control

#### Select language

Selecting the language for the multifunction display is only possible with the Audio system (> page 193) or with COMAND\*. Vehicles with COMAND\*: Refer to separate operating instructions.

The language select in the Audio system or COMAND\* is also used for the displays and messages in the multifunction display.

Available languages:

- German
- English
- Spanish
- French
- Italian

### Showing or hiding additional speedometer (vehicles with manual transmission)

You can have an additional digital speedometer shown on the multifunction display. The speed is shown in the unit of kilometers/hour (USA) or miles/hour (Canada).

- ▶ Press **▼** or **▲** to select the Instr. Cluster submenu.
- ▶ Press **OK**.
- ▶ Press **▼** or **▲** to select the Additional Speedometer function.
- ▶ Press **OK**.

The current setting is shown.



- ▶ Press **OK** again if you would like to change the current status.

Depending on the previous status, the additional speedometer will be switched On or Off.

### Permanent display (vehicles with automatic transmission\*)

You can use the Permanent Display function to choose to display either the outside temperature or the speed in kilometers (USA) or miles (Canada) permanently.

- ▶ Press **▼** or **▲** to select the Instr. Cluster submenu.
- ▶ Press **OK**.
- ▶ Press **▼** or **▲** to select the Permanent Display function.
- ▶ Press **OK**.

The current setting Outside temperature or Speedometer (km/h) (USA)/Speedometer (miles) (Canada) is shown.



- ▶ Press **OK** again if you would like to change the current status.

Depending on the previous status, the Permanent Display will be switched between Outside temperature or Speedometer (km/h) (USA)/Speedometer (miles) (Canada).

The selected display is then shown continuously in the lower display.

## Control system

### Time/date submenu

Access the Time/date submenu via the Settings menu. Use the Time/Date submenu to change the instrument cluster display settings.

The following functions are available:

Function	Page
Set the time (hours)	170
Set the time (minutes)	170
Set the date (month)	170
Set the date (day)	170
Set the date (year)	170

### Set the time

This function is not available if your vehicle is equipped with the COMAND\* system and navigation module\*.

**i** Vehicles with COMAND\*:

For information on setting the time, refer to the separate COMAND operating instructions.

- ▶ Press **▼** or **▲** to select the Instr. Cluster submenu.
- ▶ Press **OK**.
- ▶ Press **▼** or **▲** to select the Time/date function.
- ▶ Press **OK**.
- ▶ Press **▼** or **▲** to select the Time function.
- ▶ Press **OK**.

The current time appears in the multi-function display.

- ▶ To set a new time press **OK** again.
- ▶ Press button **◀** or **▶** to select the setting you wish to change: hours or minutes.



- ▶ Press button **▼** or **▲** to change the setting which is highlighted.
- ▶ Press **OK** to store the entry.

### Set the date

This function is not available if your vehicle is equipped with the COMAND\* system and navigation module\*.

**i** Vehicles with COMAND\*:

For information on setting the date, refer to the separate COMAND operating instructions.

- ▶ Press **▼** or **▲** to select the Instr. Cluster submenu.
- ▶ Press **OK**.
- ▶ Press **▼** or **▲** to select the Time/date function.
- ▶ Press **OK**.

- ▶ Press **▼** or **▲** to select the date function.

- ▶ Press **OK**.

The current date appears in the multi-function display.

- ▶ To set a new date press **OK** again.
- ▶ Press button **◀** or **▶** to select the setting you wish to change: month, day or minutes.

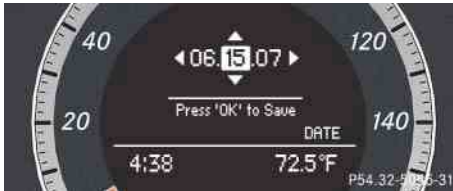

- ▶ Press button **▼** or **▲** to change the setting which is highlighted.
- ▶ Press **OK** to store the entry.

### Lighting submenu

Access the Lights submenu via the Settings menu. Use the Lights submenu to change the lamp and lighting settings on your vehicle.

The following functions are available:

Function	Page
Setting daytime running lamp mode (USA only)	171
Setting locator lighting	172
Setting interior lighting delayed shut-off	173

### Setting daytime running lamp mode (USA only)

**i** This function is not available in countries where the daytime running lamp mode is mandatory and therefore in a constant mode.

- ▶ Press **▼** or **▲** to select the Lights submenu.
- ▶ Press **OK**.
- ▶ Press **▼** or **▲** to select the Daytime Running Lamps feature.
- ▶ Press **OK**.

The current setting Enabled or Disabled is shown.

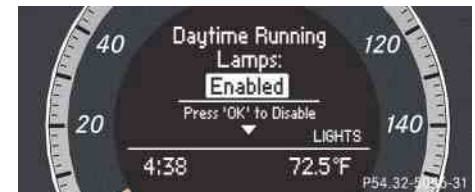

- ▶ Press **OK** again if you would like to change the current status.



### Control system

- ▷▷ Depending on the previous status, the daytime running lamps feature will be Enabled or Disabled.

With Daytime Running Lamps mode Enabled selected and the exterior lamp switch at position **0** or **A**, the low beam headlamps are switched on when the engine is running.

In low ambient light conditions the following lamps will switch on additionally:

- Parking lamps
- Tail lamps
- License plate lamps
- Side marker lamps

also illuminates the instrument cluster.

For more information on the daytime running lamp mode (> page 110).

**i** If you turn the exterior lamp switch to another position, the corresponding lamp(s) will switch on.

**i** Make sure the light switch is set to **0** or **A** when you switch off the daytime running lamps while driving at night.

**i** For safety reasons, resetting the Lights submenu to factory settings (> page 165) while driving will not deactivate the daytime running lamp mode.

The following message appears in the multifunction display:

Lighting - Cannot be completely reset to factory settings while driving.

#### Setting locator lighting

- ▶ Press **▼** or **▲** to select the Lights submenu.
- ▶ Press **OK**.
- ▶ Press **▼** or **▲** to select the Surround Lighting feature.
- ▶ Press **OK**.

The current setting Enabled or Disabled is shown.

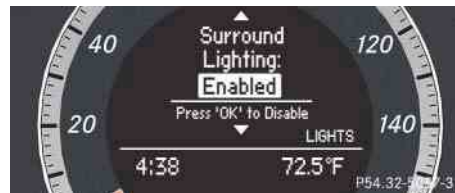

- ▶ Press **OK** again if you would like to change the current status.

Depending on the previous status, the locator lighting feature will be Enabled or Disabled.

With the locator lighting feature activated and the exterior lamp switch in position **AUTO**, the following lamps will switch on during darkness when the vehicle is unlocked with the SmartKey:

- Parking lamps
- Tail lamps
- License plate lamps
- Side marker lamps
- Front fog lamps

also illuminates the instrument cluster.

The locator lighting switches off when the driver's door is opened.

If you do not open a door after unlocking the vehicle with the SmartKey, the lamps will switch off automatically after approximately 40 seconds.

### **Setting interior lighting delayed shut-off**

Use this function to set whether you would like the interior lighting to remain on for 10 seconds during darkness after you have removed the SmartKey from the starter switch.

- ▶ Press **▼** or **▲** to select the Lights submenu.
- ▶ Press **OK**.
- ▶ Press **▼** or **▲** to select the Interior Lighting Delay feature.
- ▶ Press **OK**.

The current setting Enabled or Disabled is shown.



- ▶ Press **OK** again if you would like to change the current status.

Depending on the previous status, the interior lighting delayed shut-off feature will be Enabled or Disabled.

### **Vehicle submenu**

Access the Vehicle submenu via the Settings menu. Use the Vehicle submenu to make general vehicle settings.

The following function is available:

Function	Page
Setting automatic locking	173

### **Setting automatic locking**

Use this function to activate or deactivate the automatic central locking. With the automatic central locking system activated, the vehicle is centrally locked at vehicle speeds of approximately 9 mph (15 km/h).

- ▶ Press **▼** or **▲** to select the Vehicle submenu.
- ▶ Press **OK**.
- ▶ Press **▼** or **▲** to select the Automatic Door Lock feature. ▷▷

### Control system

▷▷ Press **OK**.

The current setting Enabled or Disabled is shown.

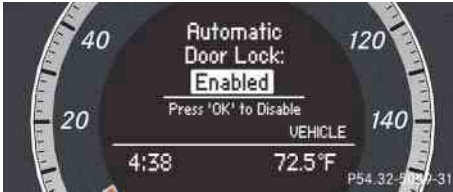

▶ Press **OK** again if you would like to change the current status.

Depending on the previous status, the automatic central locking feature will be Enabled or Disabled.

### Convenience submenu

Access the Convenience submenu via the Settings menu. Use the Convenience submenu to change the settings for the convenience features.

The following functions are available:

Function	Page
Activate easy-entry/exit feature* (Canada only)	174
Setting fold-in function* for exterior rear view mirrors	175

### Activate easy-entry/exit feature\* (Canada only)

#### Warning!



You must make sure no one can become trapped or injured by the moving steering wheel when the easy-entry/exit feature is activated.

To stop steering wheel movement, do one of the following:

- Move steering wheel adjustment stalk\* (▷ page 94).
- Press memory position switch\* (▷ page 104).

Do not leave children unattended in the vehicle, or with access to an unlocked vehicle. Children could open the driver's door and unintentionally activate the easy-entry/exit feature, which could result in an accident and/or serious personal injury.

- ▶ Press **▼** or **▲** to select the Convenience submenu.
- ▶ Press **OK**.
- ▶ Press **▼** or **▲** to select the Easy Entry/Exit feature.
- ▶ Press **OK**.

The current setting Enabled or Disabled is shown.



- ▶ Press **OK** again if you would like to change the current status.

Depending on the previous status, the easy-entry/exit feature will be Enabled or Disabled.

### **Setting fold-in function\* for exterior rear view mirrors**

Using this function, you can set the exterior rear view mirrors to be automatically folded in when you lock the vehicle.

**i** *With this function set to Enabled and the exterior rear view mirrors folded in using the button on the door control panel, the exterior rear view mirrors will not fold out when you switch on the ignition. You will then have to fold out the exterior rear view mirrors using the button on the door control panel.*

*Make sure both exterior rear view mirrors are folded out completely before driving off.*

- ▶ Press **▼** or **▲** to select the Convenience submenu.
- ▶ Press **OK**.
- ▶ Press **▼** or **▲** to select the Fold Mirrors in when Locking function.
- ▶ Press **OK**.

The current setting Enabled or Disabled is shown.



- ▶ Press **OK** again if you would like to change the current status.

Depending on the previous status, the automatic fold-in function\* for exterior rear view mirrors will be Enabled or Disabled.



## Audio system

### Audio and telephone, operation

These instructions are intended to help you become familiar with your Mercedes-Benz audio system. They contain useful tips and a detailed description of the user functions.

#### Warning!



In order to avoid distraction which could lead to an accident, the driver should enter system settings with the vehicle at a standstill and operate the system only when road and traffic conditions permit. Always pay full attention to traffic conditions first before operating system controls while driving.

Bear in mind that at a speed of just 30 mph (approximately 50 km/h), your car is covering a distance of 44 feet (approximately 14 m) every second.

### Audio system overview



Item	Page
① Audio display	180
② Opening button	180
③ Audio control unit	177



Item	Page
④ Delete button	184
⑤ Audio controller	182
⑥ Back button	184

## Operating safety

### Warning!



Any alterations made to electronic components can cause malfunctions.

The radio, amplifier, CD changer\*, satellite radio\*, and telephone\* are interconnected. When one of the components is not operational or has not been removed/replaced properly, the function of other components may be impaired.

This condition might seriously impair the operating safety of your vehicle.

We recommend that you have any service work on electronic components carried out at an authorized Mercedes-Benz Center.

## Audio system components

With the audio system you can operate the following main functions:

- audio function with the radio, Sat\*, disc (CD audio or MP3 mode)
- the telephone\* with the phone book
- various system settings

The audio system consists of the following:

- audio control unit
- audio display
- audio controller with back and delete button

In addition, the audio system can also be operated with the multifunction steering wheel (▷ page 152).

In these instructions, the keypad (right side of audio control unit) and the function buttons are referred to as “buttons”.

## Audio control unit

With the audio control unit you can:

- switch the audio system on/off
- adjust the volume
- select the operating modes
- enter telephone numbers and accept, reject, initiate and end telephone calls
- load and eject CDs

## Audio system

### Audio control unit overview



P82.86-7409-31

Item	Page
① Switching to radio mode	196
Switching wavebands	196
Switching to Sat* mode	
② Switching to CD audio or MP3 mode	213
③ Disc slot	
Loading CDs	
Ejecting CDs	
Updating the map software	
④ Load/eject button	214
⑤ Clear button for deleting digit or entire entries	184 237
Entering a passcode	228
Entering a telephone number	237

Item	Page
⑥ Keypad	
Tuning to a station via the station memory	197
Storing stations manually	198
Entering a passcode	228
Entering a telephone number	237
Sending DTMF tones	240
CD changer*: Selecting CD	217
⑦ Tuning to a station via station search	197
Fast forward	219
Selecting next track	219
⑧ Switching audio on/off	188
⑨ Setting the volume	189
⑩ Tuning to a station via station search	197
Fast reverse	219
Selecting previous track	219

Item	Page
⑪ Confirming a passcode	228
Accepting a call	239
Initiating a call	237
Redial	238
⑫ Rejecting a call	239
Ending an active call	238
⑬ Opening system menu	192
⑭ Switching sound on/off	189
Switching hands-free microphone on/off	240
⑮ Switching to telephone mode	225
⑯ Sound settings	189

### Audio system

#### Audio display

The audio display has a protective cover.

**!** Do not place any objects on the cover of the audio display. This may obstruct the movement when the cover is being opened/closed. The cover could be damaged. Do not place any objects in front of the audio display and/or secure any objects to the audio display itself. The audio display could be damaged.

Avoid touching the audio display at all times. The display has a very sensitive high-gloss surface, there is a risk of it being scratched. Do not press directly in the display face. Otherwise, the audio display will be damaged.

**i** For information about cleaning and care of the audio display, see “Audio display” (▷ page 371).

#### Audio display cover

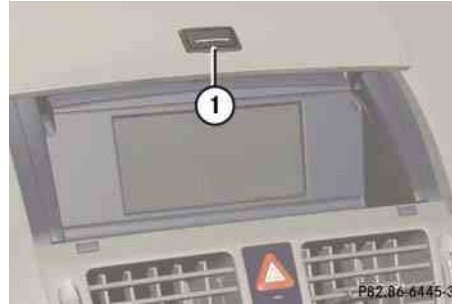

#### ① Opening button

- ▶ **Opening:** Press opening button ①.

The audio display cover opens, the audio display is visible, and the audio system switched on.

- ▶ **Closing:** Press the audio display cover down until it engages.

If the audio system is still switched on, you can continue to listen to the radio or a CD and operate the device via the buttons on the audio control panel.

**i** You cannot operate the audio system via the audio controller when the protective cover is closed.

### Display

The currently selected mode and the associated menus are shown on the audio display. The audio display is divided into several areas.



#### For example, radio selected



- ① Menu bar
- ② Main area
- ③ Status line

The status line ③ displays the time and the current settings for radio and telephone mode.

You can request the required function using the menu bar ①.

The selection is made using the audio controller.

Mobile phone readiness is indicated by additional information being shown in the status line:

- In the main menu TEL: Name of the Bluetooth® device (calls made and received via the Bluetooth® interface).
- Mobile phone network signal strength . This information will only be shown with suitable telephones.
- Receiver symbol  

In this example, the audio main function is set to the radio mode and the main area ② is active.

**i** *The layout of the menus may vary depending on your vehicle's equipment. This manual shows the menus for a fully equipped vehicle.*

### Audio system

#### Instrument cluster multifunction display

This section describes features and controls via the audio control unit, display and controller only.

Please refer to the “Instrument cluster control system” section of this manual (▷ page 151) for function descriptions and operation of the instrument cluster multifunction display and multifunction steering wheel buttons as they relate to audio functions described in this section.

#### Audio controller



#### ① Audio controller





The menu functions are selected on the audio display using the audio controller. For this purpose, a selector bar is moved.

In this way, you can open menus or lists, move within menus or lists, and quit menus or lists.







#### Operating audio controller

The audio controller features the following options:

- press briefly or press and hold 
- rotate to the left or right 
- slide to the left or right 
- slide up or down 

**i** You cannot operate the audio system via the audio controller when the protective cover is closed.

Symbol	How to use the audio controller	Function
	<ul style="list-style-type: none"> <li>▶ Press briefly.</li> <li>▶ Press and hold until the selected action has been carried out.</li> </ul>	<ul style="list-style-type: none"> <li>• Confirms the selecting of a menu item or list entry.</li> <li>• Save a station.</li> </ul>
	<ul style="list-style-type: none"> <li>▶ Rotate.</li> </ul>	<ul style="list-style-type: none"> <li>• Move through vertical or horizontal menus or through lists.</li> <li>• Move through text.</li> <li>• Program settings.</li> </ul>
	<ul style="list-style-type: none"> <li>▶ Slide.</li> </ul>	<ul style="list-style-type: none"> <li>• Move through vertical menus or lists.</li> <li>• Exit horizontal menus.</li> </ul>
	<ul style="list-style-type: none"> <li>▶ Slide.</li> <li>▶ Slide and hold.</li> </ul>	<ul style="list-style-type: none"> <li>• Move through horizontal menus.</li> <li>• Exit vertical menus.</li> <li>• Fast forward or reverse for audio CD playback.</li> </ul>



## Audio system

### Back button



① Back button **BACK**

► **Switching to the next highest menu:**

Press button **BACK** briefly.

The audio system switches to the next highest menu level within the currently active mode.

**i** You can also exit a menu or list by sliding the audio controller ←○→ or ↑○↓.

► **Switching to the main menu:** Press and hold button **BACK**.

The audio system switches to the basic menu of the currently active mode.

### Clear button



① Clear button **CLR**

► **To delete an individual character:**

Briefly press the button **CLR**.

► **To delete an entire entry:** Press and hold the button **CLR** until the entry is deleted.

## Menu

The illustration below shows the structure of the modes and their menus.

Each mode has a basic menu. In the menu line of the basic menu display are several menu items listed.

Each menu item in turn has several sub-menu items.

Button	Mode/Basic menu	Menu	Page
RADIO	Radio	Radio (FM/AM)	194
		Weather Band	194
		Sat Radio*	200
		Presets	198
		Sound	189
DISC	Disc	CD/MP3	208
		Track list/folder list	219
		CD changer*	214
		Sound	189
TEL	Telephone*	Telephone*	222
		Name	233
		Call lists	236
SYS	System	System	192
		Language	193

## Audio system

### Calling up an operating mode

- ▶ Press the respective button (RADIO, DISC, TEL, or SYS) on the audio control unit.

The basic menu of the selected mode appears in the audio display. The main area is active.

The active area is highlighted.

**i** The following screens show the audio display's day design. The appearance of the highlighted items in the menu will vary depending on the display design.



Illustration: radio function basic menu

- ▶ **Moving to the menu bar:** Slide  $\odot \downarrow$ .

### Horizontal menus



- ▶ **Moving through the menu bar:**

Slide  $\leftarrow \odot \rightarrow$  or rotate  $\{\odot\}$ .

A white bar under the menu indicates the selected menu.

- ▶ **Confirm the selected menu item:**

Press  $\odot$ .

- ▶ **Exiting the menu bar without confirming a selection:**

Slide  $\uparrow \odot$  in the opposite direction of the list orientation.

or

- ▶ Press button **BACK**.

### Vertical submenus



- ▶ **Moving through the menu:**

Slide  $\uparrow \odot \downarrow$  or rotate  $\{\odot\}$ .

A white bar under the submenu indicates the selected submenu.

- ▶ **Confirm the selected submenu item:**

Press  $\odot$ .

- ▶ **Exiting a menu without confirming a selection:**

Slide  $\leftarrow \odot \rightarrow$  in the opposite direction of the list orientation.

or

- ▶ Press button **BACK**.

### Example of how to use the audio system

Example: direct frequency input, FM 104.5 MHz.

In the descriptions below, the mode always serve as the starting point for locating the individual menu items.



Example:

**RADIO** → Radio → Enter Frequency

The individual steps for the above-mentioned example are described below.

- ▶ Press button **RADIO** on audio control unit repeatedly until desired waveband FM has been selected.
- ▶ **Switching to the menu bar:** Slide .



- ▶ **Selecting “Radio” in the menu bar:** Slide  or rotate .



- ▶ **Confirming selection:** Press .

The Radio menu is selected and a list of submenus appears.

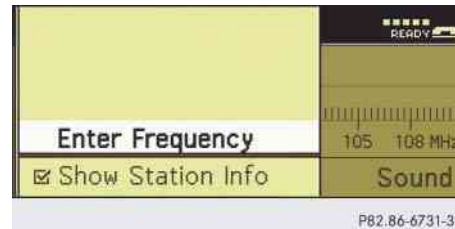

- ▶ **Selecting “Enter Frequency” in the “Radio” menu:** Slide .

- ▶ **Confirming selection:** Press .

The Enter Frequency submenu appears.



**i** It is not possible to enter a frequency in the respective waveband which is outside the frequency range. Frequencies within the current frequency range, but outside the current frequency step width are rounded to the next lower allowed frequency.

- ▶ Enter 1045 with the keypad on the audio control unit.

The audio system tunes in to the frequency entered.

## Audio system

### Operation

In the following descriptions, an operation step is described as in example below.

▶ **RADIO** → Radio → Enter Frequency

is the short for

▶ Press button **RADIO** on audio control unit repeatedly until desired waveband has been selected.

▶ Slide .

▶ Slide  or rotate  the audio controller to select Radio.

▶ Press the audio controller .

The Radio menu is selected and a list of submenus appears.

▶ Slide  or rotate  the audio controller to select Enter Frequency.

▶ Press the audio controller .

The Enter Frequency submenu is selected and appears in the audio display.

### Switching audio system on or off



#### Rotary control/push button **ON**

① Push button **ON**

② Rotary control

▶ **Switching on:** Press push button **ON**.

or

▶ Open the audio display cover.

or

▶ If the audio system was on as you switched off the ignition, turn the SmartKey in the starter switch to position **2**.

The audio system will come back on with the last selected function.

**i** If the audio system is switched on without the SmartKey in the starter switch, it will automatically switch off again after approximately 30 minutes.

If your vehicle is equipped with a telephone\*, the audio display may prompt you to enter your PIN (GSM network) or passcode (CDMA network).

▶ **Switching off:** Press push button **ON**.

or

▶ Turn the SmartKey in the starter switch to position **0**.

**i** Should excessively high temperatures occur while the audio system is being operated, HIGH TEMP will appear in the audio display, after which the audio system will be switched off for a cooling-down period.

**i** When you switch off the audio system, you also switch off the currently playing audio source and the telephone\* operating via audio control unit is not possible.

## Adjusting volume

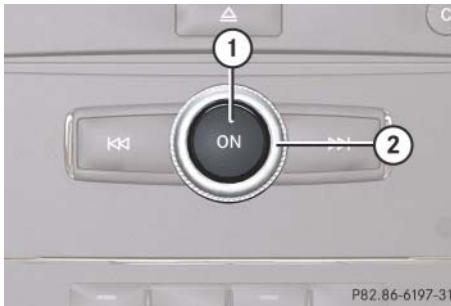

### Rotary control/push button

- ① Push button 
- ② Rotary control

#### ► **Adjusting:** Turn rotary control ②.

The volume will increase or decrease depending on the direction turned.



## Adjusting volume for telephone calls

In hands-free mode, you can adjust the volume of a telephone call while the call is currently active.

During a telephone call:

- Turn rotary control ②.

The volume will increase or decrease depending on the direction turned.

**i** The volume of the audio system or a telephone call can also be adjusted by pressing the  or  button on the multifunction steering wheel (▷ page 158).

## Sound

- **To switch on/off:** Press button  on the audio control unit (▷ page 177).

The sound of the current audio source is switched on or off.

**i** When the sound is switched off, the symbol  appears in the status line.

If you change the audio source, or alter the volume, the sound is automatically switched on again.

## Selecting sound settings

You can select different sound settings for each individual audio source. The particular Sound menu can be opened from the basic menu for the desired operating mode, or by pressing the TONE button on the audio control unit.

Example:

 → Sound → Bass

### Adjusting bass or treble

- Press TONE button repeatedly until Bass or Treble appears in the audio display.

or

- Select Sound→Bass or Treble.

The setting last selected is indicated by an red pointer. ▷▷

## Audio system

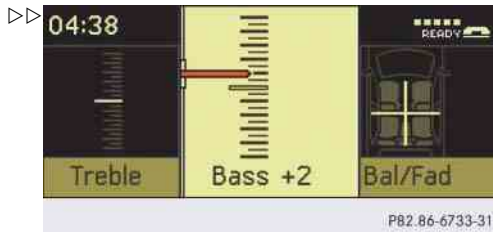

### Example Bass

- ▶ **To change setting:** Slide  $\downarrow \odot \uparrow$  or rotate  $\odot$  until desired treble or bass setting is reached.
- ▶ **To save setting:** Press  $\odot$ .  
The setting is stored and the menu is exited.
- ▶ **To exit menu without saving:** Press button **BACK** or slide  $\leftarrow \odot \rightarrow$ .

### Adjusting balance or fader

Balance is used to determine whether the sound focus should be shifted toward the driver's side or the passenger's side.

Fader is used to determine whether the sound focus should be shifted toward the front or rear of the vehicle

- ▶ Select Sound  $\rightarrow$  Bal/Fad.

The current setting is indicated by an red cross-hair symbol.

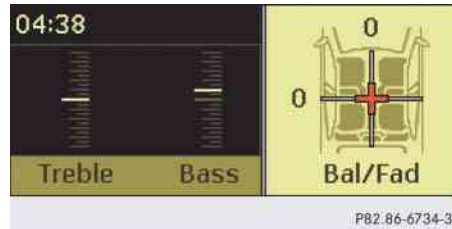

### Adjusting balance and fader

- ▶ **To change setting:** Slide  $\downarrow \odot \uparrow$  or  $\leftarrow \odot \rightarrow$  until desired balance/fader setting is achieved.
- ▶ **To save setting:** Press  $\odot$ .

The setting is stored and the menu is exited.

- ▶ **To exit menu without saving:** Press button **BACK**.

### Surround sound\* (Canada only)

If your vehicle is equipped with the harman/kardon LOGIC7® Surround Sound system, you can choose between LOGIC7® On and LOGIC7® Off for surround sound.

Harman/kardon LOGIC7® Surround Sound is available for the following operating modes:

- Radio (FM only)
- Sat\*
- CD audio
- MP3
- AUX

**i** The LOGIC7® On function of the harman/kardon LOGIC7® Surround Sound system permits the playback of discrete 5.1 and stereo recordings with an optimal surround sound platform for each passenger.

The LOGIC7® distributes the 5.1 surround information over the 13-channel system architecture to provide the optimum sound experience from all seats. This produces the sound characteristic as intended by the sound engineer during the original recording.

Harman/kardon LOGIC7® converts all two-channel stereo sound material into multi-channel surround sound. The surround information stored during the original recording is read out using LOGIC7® and likewise distributed over the 13 channels. No effects are created during this process; only that which was already there becomes audible.

In addition, harman/kardon LOGIC7® moves the perceived sound source away from the individual loudspeakers, thus generating a natural 360° sound experience for each passenger.

**i** By selecting LOGIC7® Off, all compatible formats are played back as they are present on the medium. Due to the vehicle's spatial characteristics, an optimal sound experience is not ensured from all seats.

### Adjusting surround sound

With surround sound, you can choose between LOGIC7® On and LOGIC7® Off.

▶ Select Sound → Sound.



A dot • indicates the current setting.

▶ **To select a setting:** Slide or rotate .

▶ **To save setting:** Press .

The setting is stored and the menu is exited.

▶ **To exit menu without saving:** Press button **BACK** or slide .

**i** Balance and fader will be set to the default value (0/0) automatically by activating or deactivating LOGIC7®.

**i** Please note the following:

- For an optimal sound experience from all seats, the balance and fader should be adjusted to the center of the passenger compartment with LOGIC7® switched on.
- The best sound results are achieved when playing high-quality audio CDs.
- For MP3 tracks, the bit rate should be at least 128 kbit/s.
- Surround playback cannot be activated in mono-signal sources as AM or Weatherband. It will not function for mono-signal sources as, e.g. mono audio tracks on some specific audio CDs.
- In the case of poor radio reception quality, e.g. in tunnels, LOGIC7® should be switched off, as otherwise a dynamic switchover from stereo to mono and thus temporary sound characteristic shifts can occur.
- With certain stereo recordings, the resulting sound characteristic may deviate from conventional stereo playback.



## Audio system

### SYS menu

#### SYS settings menu overview

Menu	Page
<b>System</b>	
<b>Display</b>	192
Brightness	
Day Mode	
Night Mode	
Automatic	
<b>Activate Bluetooth®</b>	192
<b>Reset</b>	193
<b>Language</b>	193

### Display settings

You can adapt the brightness of the audio display to the prevailing light conditions.

#### Setting the display design

- ▶ **SYS** → System → Display.
- ▶ Select Brightness, Day Mode, Night Mode or Automatic.

**i** When you select Brightness, a scale appears on which you can set the brightness manually.

*In the Automatic setting, the audio system analyzes the automatic vehicle light sensor and switches between the display designs automatically.*

### Bluetooth® settings

#### General information about Bluetooth®

Bluetooth® technology is the standard for short-range wireless technologies, suitable for transmitting voice and data. It is possible to connect Bluetooth® devices wirelessly. Bluetooth® can be used to exchange vCards or make calls using a hands-free device.

Bluetooth® technology uses the freely available ISM (Industrial Scientific Medical) wireless network that works at 2.45 GHz. Ranges of up to ten meters are possible with Bluetooth®.

### Activate or deactivate Bluetooth®

- ▶ **SYS** → System → Activate Bluetooth.



You have activated or deactivated Bluetooth®. A checkmark appears when Bluetooth® is activated.

### Reset

- ▶ **i** You can reset the audio system back to its factory settings. *In this case, all personal data (e.g. address book entries), among other things, are deleted. We recommend that you reset the values, for example, before selling your vehicle.*

- ▶ **SYS** → System → Reset.

A prompt appears asking whether you really want to reset.

- ▶ Select Yes or No.

If you select Yes another prompt will appear asking whether you really want to reset.

- ▶ Select Yes or No.

If you select Yes, the audio system will be reset and restarted.

### Setting the system language

- ▶ **SYS** → Language.



The language list appears. A dot • in front of an entry indicates the current setting.

- ▶ **To change the setting:** Slide  $\downarrow \odot \uparrow$  or rotate  $\{ \odot \}$  and select desired language.

- ▶ **To save setting:** Press  $\odot$ .

The setting is stored and the menu is exited.

- ▶ **To exit menu without saving:** Press button **BACK** or slide  $\leftarrow \odot \rightarrow$ .



### Audio system

▷▷ **i** *The language select in the Audio system is also used for the displays and messages in the multifunction display.*

*Available languages:*

- *German*
- *English*
- *Spanish*
- *French*
- *Italian*

### Radio operation

#### Warning!



Please devote your attention first and foremost to the traffic situation you are in.

Before your journey, please familiarize yourself with the radio functions.

Only use the audio system when road and traffic conditions permit you to do so. Otherwise you could be involved in an accident in which you or others could be injured.

**!** *Do not attach metallic film to the inside or outside of windows which are fitted with an aerial. Obstructing the metallic aerial structure on the window will interfere with radio reception. Cutting the film on the window can permanently damage the aerial wires.*

The radio mode is interrupted by an incoming call on the telephone\* (▷ page 222).

## Menu overview

 *The components and operating principles of the audios system can be found on (▷ page 187). Information about sound settings can be found on(▷ page 189).*

<b>Radio</b> (except Weather Band)	<b>Presets</b> (except Weather Band)	<b>Channel</b> (only Weather Band)	<b>Sound</b>
Enter frequency	Autostore	List of channels	Treble
Station information (in FM waveband only)	List of stored stations		Bass
			Balance/Fader
			Surround sound*

## Audio system

### Switching to radio mode

- ▶ Press button **RADIO** on audio control unit.

The radio basic menu appears in the audio display once you have switched to radio mode. You will hear the station/channel last tuned in the previously selected waveband, provided that the station/channel can be received.



**Illustration: radio mode in FM waveband**

- ① Status line
- ② Station name
- ③ Store position of station
- ④ Main area with waveband

**i** Station names ③, available for the FM waveband, can only be seen when the station transmits a name.



*In the WB waveband, the audio system displays the channel number, e.g. Channel 6, instead of the station names and/or frequency.*

### Information displayed in the status line (example)

The following information is displayed in the status line:

- Time (04:38)
- Station name (WNYC)

Mobile phone readiness is indicated by additional information being shown:

- Mobile phone network signal strength **■■■■■**
- Receiver symbol  .

### Calling up wavebands

You can choose from among the FM, AM and WB wavebands and then request the Sat mode\*. Pressing again will switch back to FM radio mode.

Waveband	Frequency
WB (Weather Band)	Weather channels
FM	87.7.....107.9 MHz
AM	530.....1710 KHz

- ▶ Press button **RADIO** on audio control unit repeatedly until desired waveband has been selected.

The FM, AM, and WB wavebands and the satellite radio\* mode are called up one after another.

The waveband currently selected appears in the status line of the audio display. The last selected station in the selected waveband is heard.

### Selecting a station/channel

You have the following selection options:

- The station search function
- The channel list (Weather Band)
- Station memory (except Weather Band)
- The manual frequency entry (except Weather Band)

The station search proceeds in the following frequency increments:

- 200 kHz in FM range
- 10 kHz in AM range

### Tuning to a station/channel via station/channel search function

**i** The search function searches for the next receivable station in the FM or AM waveband. In Weather Band (WB) the search function switches to the next channel in the channel list. For tuning to a station/channel you can also use the buttons on the multifunction steering wheel (▷ page 159).

- ▶ Press button **RADIO** on audio control unit repeatedly until the FM/AM/WB waveband is selected.

- ▶ Slide **←** or **→** or rotate **⏪** or **⏩** when the main area in the basic menu is active.

Depending on the direction in which the controller is being slid or rotated, the system searches upward or downward and stops at the next receivable station/channel.

or

- ▶ Press button **⏪** or **⏩** on audio control unit.

Depending on the pressed button, the system searches upward or downward and stops at the next receivable station/channel.

### Selecting a station using station memory

**i** This function is not available for Weather Band.

- ▶ Press **RADIO** button on audio control unit repeatedly until desired waveband has been selected.

- ▶ Select Presets.

or

- ▶ Press **⏪** when the main area is selected.

The memory menu appears. The dot **•** in front of a memory position indicates that the currently selected station is saved there.

- ▶ Select station in memory by rotating **⏪** or sliding **↑** or **↓** and press **⏪**.

or

- ▶ Press desired station button **1** to **0**, with the keypad in audio control unit briefly.

## Audio system

### Tuning to a station by entering the frequency manually

**i** This function is not available for Weather Band.

▶ **RADIO** → Radio → Enter Frequency

The menu for manual frequency entry appears.

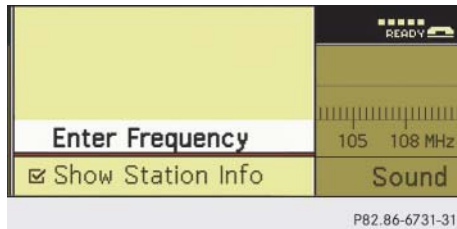

or

▶ Press button **\*+**, on the keypad in audio control unit briefly.

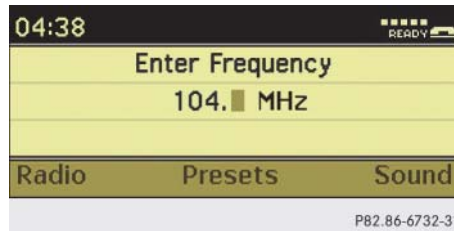

#### ▶ Enter frequency with keypad:

Enter desired frequency with buttons **1** to **0**, with the keypad in audio control unit briefly.

The audio system tunes in to the frequency entered.

**i** It is not possible to enter a frequency in the respective waveband which is outside the frequency range.

▶ **Exiting menu without making an entry:** Press button **BACK** in the center console (▷ page 184).

### Storing stations

You can store ten AM and ten FM stations in the memory.

**i** If you select a memory preset which is already in use, it will be overwritten by the new station.

#### Storing stations manually with keypad

- ▶ Tune in desired station. Basic menu is shown in the audio display.
- ▶ Press and hold desired station button **1** to **0** until a brief signal tone sounds. The station is stored.





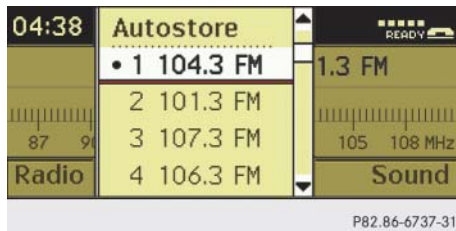

### Storing stations manually with station memory menu

- ▶ Tune in desired station.  
Basic menu is shown in the audio display.
  - ▶ Press  when the main area is active.
- or
- ▶ Select Presets.

The station memory display appears in the audio display.



The dot • in front of a memory position indicates that the currently tuned station is stored there.

- ▶ **Selecting a memory position:**  
Slide   or rotate  .
  - ▶ **Storing a station to a selected memory position:** Press and hold  until a brief signal tone sounds.
- or
- ▶ Press and hold desired station button  to  on keypad, until a brief signal tone sounds.
- The station is stored.

### Autostore – automatic station memory





 *This function is not available for Weather Band. The autostore function automatically assigns receivable stations to the memory, sorted according to reception quality at the moment of performing the autostore. The stations which were stored in the station memory manually are completely lost in this process. If less than ten stations are found, the remaining entries are left empty.*

- ▶ Press  button on audio control unit repeatedly until desired waveband has been selected.

Basic menu is shown in the audio display.

- ▶ Press  when the main area is active.
- or
- ▶ Select Presets.

The station memory display appears in the audio display.

- ▶ Slide   or rotate   to select Autostore.
- ▶ Press .

The audio system searches for receivable stations. A corresponding message is displayed. The available stations are automatically stored in memory. The first received station will be automatically played.

- ▶ **Canceling storage procedure:**  
Press  while the “Searching” message is being displayed.



## Audio system

### Satellite radio\*

#### Warning!



Please devote your attention first and foremost to the traffic situation you are in.

Before your journey, please familiarize yourself with the radio functions.

Only use the audio system when road and traffic conditions permit you to do so. Otherwise you could be involved in an accident in which you or others could be injured.

### Submenu overview

 *The components and operating principles of the audio system can be found on (> page 187).*

Sat	Presets	Info	Category	Sound
Channel List	Station presets	Show program info	All channels	Treble
Channel Entry			Select category	Bass
Service				Balance/Fader
				Surround sound*

## Satellite radio

**i** Additional satellite radio equipment and a subscription to SIRIUS Satellite Radio service provider are required for the satellite radio operation described in this chapter.

Contact an authorized Mercedes-Benz Center for details and availability for your vehicle.

SIRIUS Satellite Radio provides over 130 channels of digital-quality radio, including 100% commercial-free music, sports, news and entertainment. SIRIUS Satellite Radio uses a fleet of high-orbit satellites to broadcast 24 hours per day, coast to coast, in the contiguous U.S. and Canada.

This diverse, satellite-delivered programming is available for a monthly subscription fee.

For more information and service availability call the SIRIUS Service Center (▷ page 207) (1-888-539-7474), or contact

- [www.sirius.com](http://www.sirius.com) (USA)
- [www.siriuscanada.com](http://www.siriuscanada.com) (Canada)

**i** Note that categories and channels shown in illustrations are dependent on programming content delivered by the service provider. Programming content is subject to change. Therefore, channels and categories shown in illustrations and descriptions contained in this manual may differ from the channels and categories delivered by the service provider.

**i** Satellite radio service may be unavailable or interrupted from time to time for a variety of reasons, such as environmental or topographic conditions and other things we can't control. Service might also not be available in certain places (e.g., in tunnels, parking garages, or within or next to buildings) or near other technologies. In such situations, the satellite radio's main menu shows the "Acquiring signal..." screen. At this point, the radio's functions are restricted and the service info display (▷ page 207) appears.

## Subscribing to satellite radio

▶ Press button **RADIO** on audio control unit repeatedly until satellite radio Sat is selected.

The following options are possible:

- Satellite radio service is not activated
- Satellite radio service is fully activated

**i** If a satellite receiver is not installed or not properly installed: The message **Device unavailable will appear.** If the satellite radio service is not activated, the "SIRIUS Preview" display appears.

### Audio system

#### **Satellite radio service is not activated**

The telephone number of the SIRIUS Service Center and the twelve-digit electronic serial number (SIRIUS-ID) of the particular receiver are required when calling the SIRIUS Service Center for an activation request.

▶ **RADIO** → Sat → Service.



▶ **Closing screen:** Press .

▶ **To activate satellite radio service:** Contact satellite radio service provider at the telephone number displayed in the service display.

After the connection is made:

▶ Follow the instructions given by the operator.

The activation process may take up to 10 minutes. If it is successful, you will see the display with the message *Acquiring Signal...* followed by the satellite radio basic menu.

**i** *Activating the satellite radio service might not be available in certain places (e.g., in tunnels, parking garages, or within or next to buildings). If a subscription is not included with system purchase, credit card information is required to activate your account.*

*The activation process takes approximately 5 to 10 minutes after calling the SIRIUS Service Center.*

*If a satellite receiver is not installed or not properly installed:*

*The message Device unavailable will appear.*

**i** *It is also possible to activate the satellite radio service online. To do so please visit SIRIUS Satellite Radio's website at [www.sirius.com](http://www.sirius.com) (USA) or [www.siriuscanada.com](http://www.siriuscanada.com) (Canada).*

#### **Satellite radio service is activated**

The basic satellite radio menu appears. You will hear the channel last tuned in, provided that it can be received.

#### **Switching on**

For important subscription information see “Subscribing to satellite radio” (▷ page 201).

▶ Press button **RADIO** on audio control unit repeatedly until satellite radio Sat is selected.

The message *Acquiring Signal...* will appear when the signal is not available. After the audio system acquires the signal, the satellite radio basic menu will appear. The station last tuned to will begin to play.

## Main satellite radio menu



- ① Main area with channel display
- ② Selected program category
- ③ Number of selected channel
- ④ Selected channel
- ⑤ Sound settings
- ⑥ To select program category
- ⑦ Current artist and title
- ⑧ Channel information
- ⑨ Preset options
- ⑩ Satellite radio options

**i** Main area ① can show all channels included in your subscription. Which channels are shown depends on the selected program category ④.

*Note that categories and channels shown in illustrations are dependent on programming content delivered by the service provider. Programming content is subject to change.*

*Therefore, channel and categories shown in illustrations and descriptions contained in this manual may differ from the channels and categories delivered by the service provider.*

## Selecting program category

**i** The channels are categorized. Categories allow you to tune to stations broadcasting a certain type of program.

Satellite radio channels are split up into categories such as News, Sports News, or Country Music, if available. The category list is sorted alphabetically.

▶ **Call up category list:** **RADIO** → Cat.

or

▶ Slide ←○→ or rotate {○} until Cat is highlighted.

The category list appears.

▶ **Select a category:** Slide ↑○↓ or rotate {○}.

▶ **Set the selected category:** Press ⏻.

The selected program category (alphabetical order) will appear in the audio display. The channel last tuned in the new category will begin to play.

When searching, tuning in, or selecting from the channel list, the “All Channels” option accesses all of your subscribed channels.

**i** When you select the category “All Channels”, you have access to all the channels you subscribe to, regardless of category.



### Audio system

#### Tuning in channels

You have the following selection options:

- The channel skip function
- The manual channel number entry
- The channel list
- The channel presets

#### Tuning in channels using channel search function

- ▶ Slide  or rotate  when the main area in the basic menu is active.

Depending on the direction in which the controller is being slid or rotated, the system skips upward or downward and stops at the next subscribed channel.

or

- ▶ Press button  or  on audio control unit.

Depending on the pressed button, the system searches upward or downward and stops at the next receivable channel.



 *Which channels are available depends on which channels you have subscribed to and the program category you have selected (▷ page 203). For tuning in channels you can also use the buttons on the multifunction steering wheel (▷ page 159).*

#### Tuning in channels using manual channel number entry

- ▶  → Sat → Enter Channel.

The menu for manual channel number entry appears.

or

- ▶ Press button , on the keypad in audio control unit briefly.
- ▶ **Channel number entry with keypad:** Enter desired channel number with buttons  to , with the keypad in audio control unit briefly.

Further operation depends on whether the selected channel number is valid or if the channel is included in your subscription.

- ▶ **Exiting menu without making an entry:** Press button  in the center console (▷ page 184).

**Channel number is valid and channel is included in subscription:** The audio system tunes in the channel entered.

**Channel number is invalid:** The message *Invalid Channel* appears in the audio display.

- ▶ Press  to close the message in the audio display.

### Channel number is valid, but channel is not included in subscription:

The message Please call SIRIUS to subscribe pops up (▷ page 202).

- ▶ Press to close the message in the audio display.

### Tuning in channels using the satellite radio channel list

- ▶ **RADIO** → Sat → Channel List.

The channel list appears. The dot • in front of a list entry indicates the currently selected channel.

- ▶ Select channel by rotating or sliding .
- ▶ Press to confirm.

*The contents of the channel list depends on which channels are included in your subscription and which program category you have selected (▷ page 203). If only the preview channel is activated, the channel list contains only the preview channel.*

### Tuning in channels using satellite radio channel presets

- ▶ **RADIO** → Presets.

or

- ▶ Press when the main area is selected.

The preset menu appears. The dot • in front of a preset position indicates that this is the channel currently selected and being listened to.

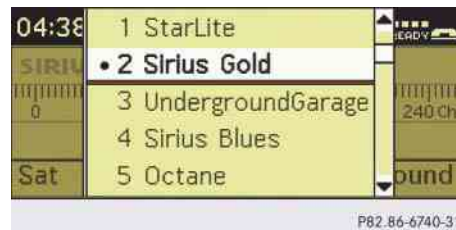

- ▶ Select station in memory by rotating or sliding .
- ▶ Press to confirm.

or

- ▶ Press desired station button **1** to **0**, with the keypad in audio control unit briefly.

The audio system tunes in the corresponding channel as long as it is included in your subscription and is still available.

If the channel is not included in your subscription, you will see the message described in the section “Satellite radio service is not activated” (▷ page 202).

If the channel is no longer available, you will see the message Invalid Channel.

- ▶ **Closing message:** Press .

## Audio system

### Storing channels

**i** There are ten preset positions available.

- ▶ Press when the main area is selected.

or

- ▶ → Presets.

In both cases, the preset menu will appear in the audio display. The dot • in front of a preset position indicates that the channel currently selected is stored there.



- ▶ **Selecting a preset position:**

Slide or rotate .

- ▶ **Storing a preset position:** Press and hold until you hear a signal.

The channel is stored.

or

- ▶ Press and hold desired channel button to on keypad, until a brief signal tone sounds.

The channel is stored.

### Show program info

- ▶ → Info.

**i** If the program provider does not offer any information, the “Info” menu item cannot be selected.

You will see a screen that may contain the following information (if available):

- Selected program category
- Selected channel
- Artist of the track currently being played
- Name of current track

**i** The program provider determines what information is displayed on the screen. The audio system shows no more than two lines per item of information. If an item of information is too long, the audio system shortens it.

With the telephone keypad button you can call up a popup screen, if provided by the program provider, that shows the name of the actor and title of the current track played on the selected channel.

- ▶ **Closing screen:** Slide or press .





## Calling SIRIUS Service Center

 *It may be necessary to call the SIRIUS Service Center if, for example:*

- *You want to cancel the subscription or re-subscribe at a later date.*
- *You forget to pay the bill.*
- *You sell the car to another person.*

▶ **RADIO** → Sat → Service.

The telephone number of the SIRIUS Service Center and the twelve-digit electronic serial number (SIRIUS-ID) of the particular receiver are displayed.

▶ **Closing screen:** Slide    or press .

## Channel update

The service provider may conduct a channel update.

During the update, the message **Updating channels...** will appear on the audio display.

The channel last tuned will be muted until the update is completed. You cannot operate the satellite radio during the update.

After completion of the update, the satellite radio basic menu will appear. The station last tuned to will begin to play. If not available, the next subscribed channel starts beginning with channel 1.

## Sound settings

For sound adjusting see:

- Volume (▷ page 189)
- Balance control and fader (▷ page 190)
- Bass and treble control (▷ page 189)
- Surround sound\* (▷ page 190)



### Audio system

#### CD mode

---

#### Submenu overview

CD or MP3	Track list (Audio CD) or Folder (MP3)	Changer (only CD-changer*)	Sound
Normal Track Sequence	Select track (CD mode only)	Select medium	Treble
Random Tracks (CD mode only)	Select folder and/or tracks (MP3 mode only)	Eject All	Bass
Random Folders (MP3 mode only)		Fill Empty Slots	Balance/Fader
AUX			Surround sound*

**i** *The components and operating principles of the audio system can be found on (> page 187).*

The audio system will be fitted with either a single CD drive or a CD changer\*.

The single CD player and the CD changer\* can play audio CDs as well as CDs with MP3 files.

The available menu options will vary depending on the equipment and the type of CD.

## Safety precautions

**Warning!**

The single CD player and the CD changer\* are classified as a Class 1 laser product. You must not open the casing. There is a risk of exposure to invisible laser radiation if you open the casing, or if the casing is faulty or damaged.

The single CD player and the CD changer\* do not contain any parts that you are able to maintain yourself. For safety reasons, all maintenance work must be carried out by qualified technicians.

**Warning!**

Only carry out the following when the vehicle is stationary:

- Inserting a disc
- Ejecting a disc

There is a risk of accident by being distracted from road and traffic conditions if you load a CD while the vehicle is in motion.

Bear in mind that at a speed of just 30 mph (approximately 50 km/h), your vehicle is covering a distance of 44 feet (approximately 14 m) every second.

## General notes

**i** Audio CDs with copy protection are not compatible with the CD audio standard and therefore may not be able to be played by the single CD player and/or the CD changer\*. There may be playback problems when playing copied discs.

*There is a large variety of discs, disc-writing software and writers available. This variety means that there is no guarantee that the system will be able to play discs that you have written/copied yourself.*

*There may be playback problems if you use CD-R or CD-RW type discs you have copied yourself with a storage capacity of more than 700 MB. These CDs are not compatible with currently applicable standards.*

**!** *If you affix stickers to the CDs, they can become warped due to the heat that develops in the CD drive or CD changer\*.*

*In certain situations, the CDs can no longer be ejected and can cause damage to the drive. Such damage is not covered by the Mercedes-Benz Limited Warranty.*

### Audio system

**!** *Your CD drive or CD changer\* has been designed to play CDs which correspond to the IEC 60908 standard. You can therefore only use CDs with a maximum thickness of 1.3 mm.*

*If you insert thicker discs, e.g. ones that have data on both sides (one side with DVD data, the other side with audio data), they cannot be ejected and will damage the drive.*

Do not use CDs with an 8 cm diameter. Attempting to play CDs with an 8 cm diameter or playing such CDs with an adapter may cause damage to the CD drive. Such damage is not covered by the Mercedes-Benz Limited Warranty.

Only use round, 12 cm diameter discs.

Should excessively high or low temperatures occur while in CD changer mode\*, CD ERROR will appear in the display, and the CD will be muted until the temperature has reached an acceptable level for the system to continue operation.

The single CD player and the CD changer\* can play audio CDs as well as CDs with MP3 files.

#### **Tips on handling CDs**

- Only touch the CDs at the edges.
- Handle CDs carefully to prevent interference during playback.
- Avoid scratches, fingerprints and dust on the CDs.
- The CDs must only be labeled using pens specially designed for this purpose.
- Clean CDs from time to time with a commercially available cleaning cloth. Never wipe the CD in a circular motion; instead, wipe it in a straight line starting in the center and moving outward. Do not use solvents, anti-static sprays, etc. for cleaning.
- Replace the CD in its case after use.
- Protect CDs from heat and direct sunlight.

#### **Notes about MP3 mode**

The single CD player and the CD changer\* can play audio CDs as well as CDs with MP3 files.

**i** *Due to the branched data structure, playback of the first track may be delayed slightly.*

#### **Permissible media for MP3 files**

- CD-DA
- CD-R
- CD-RW

#### **Permissible file systems**

- ISO9660/Joliet for CDs

### ***Multisession CDs***

For multisession CDs, the first session type of the CD determines how the audio system will process the CD.

For example, if the first session type is according to the audio CD standard and the second session type is according to the data CD standard containing MP3 tracks, the audio system will treat the CD as a conventional audio CD. This means that it is only possible to access the audio CD tracks. Access to the MP3 tracks is not possible.

Similarly, if the first session type is according to the data CD standard containing MP3 tracks and the second session type is according to the audio CD standard, the audio system will treat the CD as a data CD. This means that it is only possible to access the MP3 tracks. Access to the audio CD tracks is not possible.

### ***File structure on a disc***

When you create an MP3 disc, the MP3 tracks can be organized in folders. A folder can also contain other folders. A disc can contain a maximum of 255 folders. Each folder can contain a maximum of 255 tracks and 255 folders. A disc can contain a maximum of 4000 tracks. Usually this number will not be reached because each minute of an MP3 track requires approximately 1 MB of storage space.

### ***Track and folder names***

When you create an MP3 disc, you can assign names to the MP3 tracks and folders.

The audio system uses these names for the corresponding display in MP3 mode. Empty folders or folders which contain data other than MP3 tracks are not displayed by the audio system.

If MP3 files are saved in the root directory itself (uppermost directory on storage medium), the root directory will also be treated as a folder. The audio system will then show the name of the root directory as the folder name.

### Audio system

You must observe the following when assigning track names:

- Track names must have at least one character.
- Track names must have the extension “mp3”.
- There must be a period between the track name and the extension.

Example of a correct track name:

Track1.mp3

The audio system is unable to recognize an MP3 track if:

- there is no period between the track title and the extension
- there is no extension

**i** *The audio system does not support ID3 tags.*

#### **Permissible MP3 formats**

The audio system supports the MPEG1 Audio Layer 3 format.

**i** *This format is generally known as “MP3”.*

#### **Compatible file systems and compression methods**

The following compression methods are compatible:

- MP3
- WMA

**i** *If music files, created with different compression methods, in addition to MP3 files, are stored together on a disc, the loading process may take longer before the first track is played.*

#### **Permissible bit and sampling rates**

- Fixed and variable bit rates up to 320 kbit/s
- Sampling rates of 24 kHz – 48 kHz

**i** *Only use MP3 tracks with a bit rate of at least 128 kbit/s or higher and a sampling rate of at least 44.1 kHz or higher. Smaller rates can cause a noticeable deterioration in sound quality. This is especially the case if you have activated the surround sound\* function.*

#### **Notes on copyright**

The music tracks that you create for MP3 mode and can play back in MP3 mode are generally subject to copyright protection in accordance with the applicable international and national regulations.

In many countries, reproductions are not permitted without the prior consent of the copyright holder, not even for private use.

Make sure you know the applicable copyright regulations and that you comply with these.

If you own these rights yourself, e.g. for your own compositions and recordings, or the copyright holder has granted you permission, these restrictions do not apply.

### Operating the CD player

The single CD drive and the CD changer\* have the same controls.



- ① CD slot
- ② Eject/load button
- ③ Forward
- ④ Rewind

### Single CD player

► **Switching to CD mode:** Press button **DISC** on the audio control unit.

The CD display appears when you switch to CD mode. CDs start to play automatically when they are inserted. The following message will appear if no CD is inserted.



### Warning!



Only insert a CD when the vehicle is stationary. There is a risk of accident by being distracted from road and traffic conditions if you load a CD while the vehicle is in motion.

Bear in mind that at a speed of just 30 mph (approximately 50 km/h), your vehicle is covering a distance of 44 feet (approximately 14 m) every second.

**!** *If a CD is already loaded, it must be ejected before inserting a new CD. Inserting a second CD in the slot with another CD still loaded will cause damage to the CD drive not covered by the Mercedes-Benz Limited Warranty.*

### Audio system

- ▶ **Ejecting a CD:** Press eject/load button ②.

The system ejects the CD. Please Remove Disc appears in the display.

- ▶ Remove CD from CD slot ①.

NO Disc appears in the display.

**i** If you do not take the CD out of the CD slot ① within approximately 15 seconds, the system automatically pulls the CD back in and plays it.

If a CD is pulled back in, press eject/load button ② again; the CD will then be ejected.

**i** If the audio CD is printed on one side, this side must face upwards when loaded. If neither side is printed, the side to be played must face downwards.

If a CD has been inserted incorrectly or cannot be read, Disc Unreadable appears in the display.

- ▶ **Loading a CD:** Insert CD into CD slot ①.

The system automatically pulls the CD into the CD slot ① and starts to play the audio CD if it has been inserted correctly and is permissible.

#### CD changer\*

The CD changer can hold up to a total of 6 audio CDs

- ▶ **Switching to CD mode:** Press button **DISC** on the audio control unit.

The CD changer display appears when you switch to CD changer mode. If there is a CD in one of the magazine trays, it will start to play automatically. The following message will appear if no CDs are inserted.



#### Warning!



Only insert a CD when the vehicle is stationary. There is a risk of accident by being distracted from road and traffic conditions if you load a CD while the vehicle is in motion.

Bear in mind that at a speed of just 30 mph (approximately 50 km/h), your vehicle is covering a distance of 44 feet (approximately 14 m) every second.

**i** If the audio CD is printed on one side, this side must face upwards when loaded. If neither side is printed, the side to be played must face downwards.

If a CD has been inserted incorrectly or cannot be read, Disc Unreadable appears in the display.

- ▶ **Loading an individual magazine compartment:** Press eject/load button ②.

A menu indicates which magazine compartments are currently loaded. The first available magazine compartment is indicated by a red number.

- ▶ Press desired button **1** to **6 MNO**, in the keypad to select a magazine compartment.

or

- ▶ Slide ←⊙→ or rotate ⊙↻ to select a magazine compartment.

- ▶ Press ⊙ to confirm.

The CD changer will switch to the selected magazine compartment. The message Please Wait... appears in the display.

**i** Only insert a CD after the audio system has prompted you to do so with the message Please Insert Disc <X>. Only insert one CD per magazine compartment.

- ▶ Insert CD into CD slot ①.

The CD changer automatically pulls the CD into the CD slot ① and places it in the selected magazine compartment. The message Loading Disc <X> appears in the display.

**i** The loading process may take a while, depending on the type of disc. If you do not insert a disc, the display will switch back to the Magazine menu after approximately 20 seconds.

- ▶ Press button **DISC**, or the eject/load button ② on the audio control unit to finish the loading process.

The CD changer plays the disc if it has been inserted correctly and is permissible.

- ▶ **To interrupt loading procedure:** Press the eject/load button again.

or

- ▶ Press button **BACK** in the center console (▷ page 184).



### Audio system

- ▶ **Filling an empty magazine compartments:** Press eject/load button ②.

A menu indicates which magazine compartments are currently loaded. The first available magazine compartment is indicated by a red number.

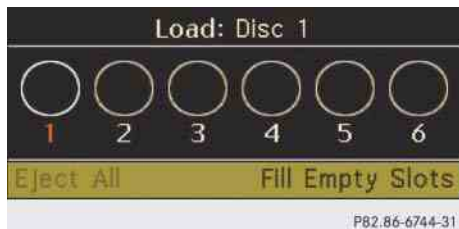

- ▶ Slide to select the menu bar.
- ▶ Slide or rotate the audio controller to select **Fill Empty Slots**.
- ▶ Press the audio controller .

The message **Please Insert Disc <X>** appears in the display.

**i** Only insert a CD after the audio system has prompted you to do so with the message **Please Insert Disc <X>**. Only insert one CD per magazine compartment.

- ▶ Insert CD into CD slot ①.

The CD changer automatically pulls the CD into the CD slot ① and places it in an empty magazine compartment. The message **Please Wait...** appears in the display. If the CD is loaded, the CD changer will switch to the next empty magazine compartment. The message **Please Insert Disc <X>** appears in the display.

- ▶ Repeat the steps until all compartments have been loaded.
- ▶ Press eject/load button ② on the audio control unit to finish the loading process.

The CD changer plays the last loaded disc if it has been inserted correctly and is permissible.

- ▶ **To interrupt loading procedure:** Press the eject/load button ② again.

or

- ▶ Press button **BACK** in the center console (▷ page 184).

The loading process has not been completed, the audio system will play the last inserted CD.

#### Ejecting CDs from CD changer\*

##### Warning!



Only eject a CD when the vehicle is stationary. There is a risk of accident by being distracted from road and traffic conditions if you unload a CD while the vehicle is in motion.

Bear in mind that at a speed of just 30 mph (approximately 50 km/h), your vehicle is covering a distance of 44 feet (approximately 14 m) every second.

**i** If you eject a CD while another is being played, the audio system interrupts playback. Playback will continue once the CD has been ejected completely.

- ▶ **Ejecting one CD:** Press eject/load button ②.

The magazine menu with active main area appears in the audio display. The magazine compartment with the current CD is highlighted.



- ▶ Press desired button 1 to 6, in the keypad to select a magazine compartment.

or

- ▶ Slide ←→ or rotate ⏪⏩ the audio controller to select the desired CD.
- ▶ Press ⏹ to confirm.

- ▶ Remove the CD from CD slot ①.

If you do not remove the CD from the CD slot ①, the CD changer will automatically pull the CD back in after a short while.

- ▶ **Ejecting all CDs:** Press eject/load button ②.

The magazine menu with active main area appears in the audio display. The magazine compartment with the current CD is highlighted.



- ▶ Slide ⏪ to select the menu bar.
- ▶ Slide ←→ or rotate ⏪⏩ the audio controller to select "Eject All".

- ▶ Press ⏹ to confirm.

The CDs are ejected one after the other.

- ▶ Remove the CD from CD slot ①.

The CD changer switches to the next occupied magazine compartment and ejects the CD.

If you do not remove the CD from the CD slot ①, the CD changer will automatically pull the CD back in after a short while.

- ▶ Repeat the last step until the magazine is empty.

### Selecting a CD

- ▶ **DISC** → Changer.

The magazine menu with active main area appears in the audio display. The magazine compartment with the current CD is highlighted.

- ▶ Slide ←→ or rotate ⏪⏩ the audio controller to select the desired CD.
- ▶ Press ⏹ to confirm.

## Audio system

### Playing CDs

**i** The following section is valid for the single CD player and the CD changer\*. The illustrations show the audio display of the CD changer\*.

### Additional button functions

In CD mode, you can use two additional buttons on the telephone keypad:

#  
↕

displays information about the track, if this has been saved with the track on the CD.

\*  
+

enables you to enter the track number directly.

### Example display in audio CD mode



- ① Track number
- ② Track name (only if saved on the disc)
- ③ Elapsed track time
- ④ Disc name (only if saved on the disc)
- ⑤ Disc number (CD changer\*)
- ⑥ Disc type

### Example display in MP3 mode

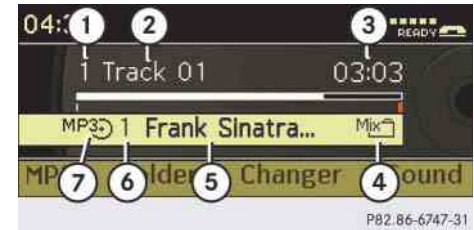

- ① Track number
- ② File name
- ③ Elapsed track time
- ④ Mode
- ⑤ Folder name (only if saved on the disc)
- ⑥ Disc number (CD changer\*)
- ⑦ Disc type

### Pause function

#### ▶ Pausing playback:

Press  briefly.

#### ▶ Continuing playback: Press

again briefly.

### Selecting a track

- ▶ **Skipping forwards or backwards to a track:** Rotate or slide .

or

- ▶ Briefly press button or on audio control unit.

*Skipping forwards through the tracks skips to the next track. Skipping backwards through the tracks skips to the beginning of the current track if the track has been playing for more than 8 seconds. If the track has been playing for less than 8 seconds, it skips to the start of the previous track.*

*If you have switched on the “Random Tracks” playback option, the order of the tracks is random.*

- ▶ **Selecting from the track list:**

→ Track List.

or

- ▶ Press when the main area is selected.

The track list appears. In MP3 mode, the track list of the current folder appears. The dot ● indicates the current track.

- ▶ Select a track by rotating or sliding .
- ▶ Press to confirm.

*In MP3 mode, the list shows all the tracks in alphabetical order.*

### Fast forward/rewind

- ▶ Select main area.
- ▶ Slide and hold until desired place is reached.

or

- ▶ Press and hold button or on audio control unit.

### Selecting a folder

*This function is only available in audio MP3 mode.*

- ▶ → Folder.

or

- ▶ Press when main area is selected.

The track list of the current folder appears.

- ▶ **Selecting one folder higher:** Select the symbol.

The display changes to the next folder up in the folder structure on the disc.

- ▶ **Selecting a folder:** Slide or rotate the audio controller, to select the desired folder.

- ▶ Press to confirm.

You will see the tracks in the folder.

### Audio system

▷▷▶ Select a track by sliding or rotating the audio controller.

▶ Press to confirm.

The track is played and the corresponding folder is now the active folder.

#### Playback options

The following options are available:

- Normal Track Sequence  
Tracks playback in the order on the disc (e.g. track 1, 2, 3, etc.).
- Random Tracks  
Tracks playback in a random order (e.g. track 3, 8, 5, etc.).
- Random Folder (in MP3 mode only)  
Tracks in the active folder and any subfolders playback in random order.

▶ **Selecting an option:** → CD/MP3.

The option list appears. A dot ● indicates which option is switched on.

▶ Select an option and press .

The option is switched on. For all options except Normal Track Sequence, you will see a corresponding indicator in the main area.

The “Normal Track Sequence” option is automatically activated when you select a different medium. If an option is activated, it remains activated after the audio system is switched on/off.

#### Audio Aux mode

An external audio source (Aux) can be connected to the audio system. The cinch-connector for connecting the external audio source (Aux) is located in the glove box. Please contact an authorized Mercedes-Benz Center for more information

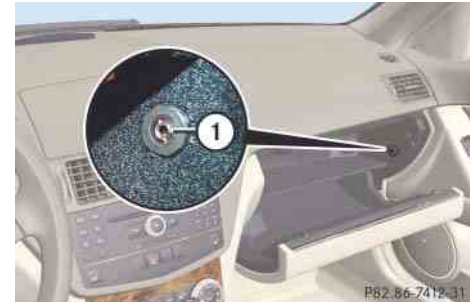

① External audio source (Aux) cinch-connector

**Warning!**

Only operate an external audio source (Aux) when the vehicle is stationary. There is a risk of accident by being distracted from road and traffic conditions if you operate an external audio source (Aux) while the vehicle is in motion.

Bear in mind that at a speed of just 30 mph (approximately 50 km/h), your car is covering a distance of 44 feet (approximately 14 m) every second.

**Calling up Aux mode****Warning!**

Due to the different volumes of the external audio sources, system messages (e.g. traffic and navigation announcements) may be much louder. You may need to disable these system messages or adjust the volume of these messages manually.

**▶ Selecting audio Aux mode:**

**DISC** → CD/MP3 → Aux.

The audio Aux menu appears. The medium in the external audio source is heard, provided it is connected and switched to playback.

**i** Please refer to the relevant operating guide for operation of the external audio source.

The following settings can be made in the audio Aux mode:

- Volume (▷ page 189)
- Balance control and fader (▷ page 190)
- Bass and treble control (▷ page 189)
- Surround sound (▷ page 190)

**i** *The volume of external audio sources is extremely variable. It is possible that a device connected as an external audio source will sound quieter or louder in the vehicle or that the usual maximum volume cannot be achieved. On certain devices the volume can be set separately. In this case, start at a moderate volume and increase it slowly. In this way, you can determine whether the system is capable of playback without distortion, even at high volume.*

**Switch back to CD mode**

- ▶ Select Back To Disc in the audio Aux menu.

The CD mode is switched on.

## Audio system

### Telephone\*

#### Safety precautions

##### Warning!



Some jurisdictions prohibit the driver from using a cellular telephone while driving. Whether or not prohibited by law, for safety reasons, the driver should not use the cellular telephone while the vehicle is in motion. Stop the vehicle in a safe location before placing or answering a call.

If you nonetheless choose to use the telephone<sup>1</sup> while driving, please use the hands-free device and be sure to pay attention to the traffic situation at all times. Use the telephone only when road, weather and traffic conditions permit. Otherwise, you may not be able to observe traffic conditions and could endanger yourself and others.

<sup>1</sup> Observe all legal requirements.

Bear in mind that at a speed of just 30 mph (approximately 50 km/h), your vehicle is covering a distance of 44 feet (approximately 14 m) every second.



##### Warning!



Never operate radio transmitters equipped with a built-in or attached antenna (i.e. without being connected to an external antenna) from inside the vehicle while the engine is running. Doing so could lead to a malfunction of the vehicle's electronic system, possibly resulting in an accident and/or personal injury.

**i** *The functions and services available to you while using the telephone depend on your service provider and the type of telephone you are using. See also separate operating manual for instructions on how to use your telephone.*

When the telephone is connected via the Bluetooth® interface to the audio system, you can operate the telephone using the following devices:

- audio system (▷ page 237)
  - Audio controller
  - Audio control unit
- buttons  and  on the multi-function steering wheel (▷ page 152)
- mobile phone keypad

Please note that these functions are only available with Mercedes-Benz approved telephones.

## TEL Menu

Telephone	Name	Call lists Microphone off/on
Phone list	Phone book	Call Lists
Receive Business Card(s) (vCards)		Delete Call Lists Mic On/Mic Off
Delete external data		

## General notes

***Making calls via Bluetooth® interface***

The audio system telephone function via the Bluetooth® interface is available in conjunction with a Bluetooth® enabled telephone.

With a suitable telephone, you can use the hands-free device and receive electronic business cards (vCards) via the Bluetooth® interface.

Further information on suitable telephones and on connecting Bluetooth® enabled telephones to the audio system are available at an authorized Mercedes-Benz Center.

***Calls disconnected while the vehicle is in motion***

Interruptions to the connecting may occur if

- there is insufficient mobile network coverage in certain regions.

- you move from one mobile network transmitter/receiver area (mobile network cell) into another and no channels are free or the cell is full.
- you are using a SIM card that is not compatible to the available network.
- when using a telephone with “Twin-card”, the telephone is simultaneously logged into the network with the second SIM card.





### Audio system

#### Operating options

**i** The components and operating principles of the audio system can be found on (▷ page 177) and (▷ page 187).

When the telephone is connected via the Bluetooth® interface to the audio system, you can operate the telephone using the following devices:

- buttons  and  and keypad on audio control unit
- audio controller in center console
- multifunction steering wheel

Please note that these functions are only available with Mercedes-Benz approved telephones. Please contact an authorized Mercedes-Benz Center for information on features available for your telephone of choice.

**i** In order for the functions described in this section to work correctly, the Bluetooth® telephone must be linked to the audio system (▷ page 192). Please make sure any other Bluetooth® device linked with the telephone is switched off before you use the telephone functions with the audio system.

Unless otherwise indicated, the descriptions and illustrations in this section refer to audio system.

#### Caller ID

The audio system can display the telephone number and the name of the caller, e.g. for an incoming call and also in other menus or displays.

For the telephone number to be displayed, the caller must transmit their telephone number.

This is also the case for name displays. For this, the telephone number and the name of the caller must also be saved in the telephone book.

### **Functional restrictions**

You will not be able to use the telephone, or you may have to wait a while, in the following situations:

- If the telephone is switched off.
- If the telephone is not connected via the Bluetooth® interface to the audio system.
- The telephone must not be locked.
- If the telephone has not yet logged into the network.

The telephone automatically tries to log into a network. If no network is available, you will also not be able to make a “911” emergency call.

If you attempt to make an outgoing call, the *No Service* message will appear for a short while.

- If you switch off the audio system in the middle of a call, e.g. by switching off the ignition, that call will be cut off. You can prevent this from happening as follows:
  - Switch the phone to “private mode” before switching the audio system off (see telephone operating instructions).

### **Activating the telephone**

#### ***Prerequisites for the telephone***

For making calls using the audio system via the Bluetooth® interface, you will need a Bluetooth® enabled telephone.

Before attempting to make or receive calls via the Bluetooth® interface, check your phone's hands-free profile. It must support version 1.0 or higher (see telephone operating instructions).

 *Not all telephones on the market are suitable. Further information on suitable telephones and on connecting Bluetooth® enabled telephones to the audio system are available from an authorized Mercedes-Benz Center.*

### Audio system

#### Activating Bluetooth®

- ▶ Switch on the telephone (see telephone operating instructions).
- ▶ Enter the PIN (not necessary at each telephone or network).
- ▶ Activate Bluetooth® connection on the telephone (see telephone operating instructions)
- ▶ Press button **TEL** on the audio control unit to call up the telephone mode.

**i** *On certain telephones, not only do you have to activate the Bluetooth® function but your own device must additionally be made “visible” for other devices.*

*Each Bluetooth® device has a Bluetooth® device name. It is recommended to give your telephone a personal name, by which you can clearly recognize your telephone.*

**i** *If the Bluetooth® function on the audio system is disabled, the message Bluetooth not activated in system settings appears.*

- ▶ Activate Bluetooth® connection on the audio system (▷ page 193).

- ▶ **SYS** → System → Activate Bluetooth.

You have activated or deactivated Bluetooth®. A checkmark appears when Bluetooth® is activated.

#### Registering a telephone (authorizing)

When you use your telephone in conjunction with the audio system for the first time, you must register (authorize) it.

It is possible to register several telephones. The connection is always established to the last activated telephone in signal range. When you authorize a new telephone, it is activated automatically. You can switch between the authorized telephones.

#### Searching for a telephone

- ▶ **TEL** → Tel → Phone List → Update.

The audio system searches for suitable Bluetooth® telephones within range and enters them in the telephone list.

Authorized Bluetooth® telephones will be identified by a telephone-symbol in front of the list entry once the telephone list has been updated. (The symbol will be grayed out if the authorized phone is not located in the Bluetooth® range.)

**i** *The duration of the search procedure depends on the number and type of Bluetooth® telephones. The search may take a few minutes.*

**i** *If the telephone list is already full (15 entries), you must de-authorize one of the authorized devices. Then you will start the search again. Otherwise a new device you are looking for will not appear in the list.*

*If the audio system does not find your phone, external authorization may be necessary (▷ page 228).*

**Authorizing a Bluetooth® device**

- ▶ Select the desired unauthorized device from the telephone list by pushing the audio controller.

or

- ▶ Select Options → Authorize.

The input menu for the passcode appears.



**i** The passcode is any one- to sixteen-digit number, which you can set yourself. For the quality of coding of the connection it is recommend to use a passcode of at least four digits. You must enter the same number in the audio system and also in the device to be authorized. Please also refer to the instructions in the telephone operating guide.





On the audio system, you can enter the passcode via the digits in the on-screen menu bar or via the telephone keypad in the audio control unit.

**With the audio controller:**

- ▶ **Entering passcode:** Select the digits in the menu bar one by one, by sliding ←→ or rotating ↻ the audio controller.
- ▶ Press ↻ to confirm each digit.
- ▶ **Confirming passcode:** Select  in the menu bar and press ↻ to confirm.
- ▶ **Deleting digits:** Select  in the menu bar and briefly press ↻ to delete one digit, or press and hold ↻ to delete all entered digits.
- ▶ **Canceling entry:** Press button  in the center console (▷ page 184).

### Audio system

#### With keypad on audio control unit:

- ▶ **Entering passcode:** Press the desired numbers on the keypad.
- ▶ **Confirming passcode:** Press button  or button  in the audio control unit to confirm.
- ▶ **Deleting digits:** Briefly press button  in the audio control unit to delete one number, or press and hold button  to delete all entered numbers.
- ▶ **Canceling entry:** Press button  in the center console (▷ page 184).

#### Entering passcode into the telephone

If a Bluetooth® connection is established successfully, you will be prompted to enter a code into the telephone (see the operating instructions for the telephone).

- ▶ Enter the same passcode on the telephone as you did on the audio system.

 *You may need to enter a confirmation once you have entered the passcode on your phone. Check your phone display.*

*If the message Authorization Procedure Unsuccessful appears on the audio system display, you may have exceeded the preset period for authorization. Repeat the process.*

The device is authorized. You can now make calls via the audio system hands-free device using the authorized telephone.

#### External authorization

If the audio system cannot find your telephone, this may be due to special security settings on your telephone. In this case, you can check whether, conversely, your telephone can find the audio system. The audio systems Bluetooth® device name is “MB Bluetooth”.

- ▶  → Tel → Phone List → Update → Options → External Authorization.
- ▶ Start Bluetooth® search procedure on the telephone (see the operating instructions for the telephone).
- ▶ Select the audio system (“MB Bluetooth”).
- ▶ When prompted to do so, enter the passcode on the telephone and then on the audio system.

**Displaying details on a telephone**

- ▶ **TEL** → Tel → Phone List.
- ▶ Select the telephone from the list.
- ▶ Select Options → Details.

The details screen for the device is shown in the audio display.

- ▶ **To close details screen:**  
Slide ←Ⓞ→ the audio controller or press button **BACK** in the center console.

**De-authorizing a Bluetooth® device**

- ▶ **TEL** → Tel → Phone List.
- ▶ Select authorized device.
- ▶ Select Options → De-Authorize.

A prompt appears asking whether you really want to de-authorize this device.

- ▶ Select Yes or No.

If you select Yes, the device will be de-authorized.

**i** If you de-authorize a device which has been authorized in the past and which is not detected in the search, this device will no longer be displayed in the device list.

*Devices which have been authorized in the past but which are not detected in the search are either not switched on or not in the vehicle.*

**Activating another telephone**

If you have several authorized telephones, you can switch between the individual telephones.

**i** You cannot switch to another authorized phone during a call.

When you authorize a new telephone, it is automatically activated. Only one telephone can be active at a time.

- ▶ **TEL** → Tel → Phone List.

- ▶ Select an authorized telephone from the list.
- ▶ Press  to confirm.

The selected phone will be searched for and connected if it is located in the Bluetooth® range and Bluetooth® is activated on the corresponding device.

The selected telephone is activated.

A dot • in front of the entry, indicates the current active telephone in the phone list.

**Receiving business cards**

You can import business cards (vCards) into the address book from external Bluetooth® devices (▷ page 233).

## Audio system

### TEL-Basic display

- ▶ Press button **TEL** on the audio control unit to call up the telephone mode.



When the connected phone is ready for operation, the display will look like this:



The following information is displayed in the status bar:

- Actual time:  
04:38
- Bluetooth® device name of the connected phone, in this case:  
blue\_mobil
- Mobile phone network signal strength **■■■■■**. This information will only be shown with suitable telephones.







The bars indicate the current signal strength of the mobile phone network for reception. Optimum reception is indicated by all bars full. All bars empty indicates very poor or no reception.

- Receiver symbol  or . The receiver symbol indicates whether a call is being connected or is in progress:  
 - not active
- **READY** indicates that a call is possible.
- **NO SERVICE** indicates that the mobile network is not available.

### Setting transmit and receive volume

**i** These settings should normally not be changed as the factory settings are matched to most mobile phones. Find out about the optimum settings for your mobile phone at an authorized Mercedes-Benz Center.

**i** Changes may result in significant impairments to the transmission quality. These settings may not be changed during an active phone call.

- ▶ **TEL** → Tel → Phone List.
- ▶ Select an mobile phone from the list.
- ▶ Select Options → Reception Volume or Transmission Volume.
- ▶ **To set the volume:** Slide   or rotate  the audio controller.  
The volume bar moves up or down.
- ▶ **To confirm selection:** Press  or slide   the audio controller.

## “911” emergency call

**i** The “911” emergency call system is a public service. Using it without due cause is a criminal offense.

**i** This function places a call to the local 911 provider. It does not initiate a Tele Aid call.

The following describes how to dial a “911” emergency call using the audio system head unit when a Mercedes-Benz specified mobile phone\* is connected via the Bluetooth® interface to the audio system. Unless otherwise specified, the descriptions refer to the audio system head unit.

Consult the separate telephone operating instructions that came with your mobile phone\* for information on how to place a “911” emergency call on the mobile phone\*.

The following conditions must be met for a “911” emergency call via the audio system:

- Telephone must be switched on.
- The corresponding mobile communications network must be available.

**i** *Emergency calls may not be possible with all telephone networks or if certain network services and/or telephone functions are active. Check with your local service providers.*

If you cannot make an emergency call, you will have to initiate rescue measures yourself.

## GSM network phones

### **Placing a “911” emergency call using audio control unit with the phone unlocked**

- ▶ Press **TEL** button to switch to telephone mode.
- ▶ Enter 911 using the number keypad on the audio control unit.

- ▶ Press  button.

or

- ▶ Press  for dialing to begin.

DIALING appears in the audio display while the telephone establishes the connection.

- ▶ Wait until the emergency call center answers, then describe the emergency.



### Audio system

**i** If no SIM card is in the mobile phone, with a few types of mobile phones NO SERVICE appears in the audio display. In that case, you only can make an emergency call on the mobile phone itself, without the use of the audio control unit.

#### **Placing a “911” emergency call with the phone locked**

**i** If the mobile phone is locked, you only can make an emergency call on the mobile phone itself, without the use of the audio control unit.

#### **CDMA network phones**

##### **Placing a “911” emergency call using audio control unit with the phone unlocked**

- ▶ Press **TEL** button to switch to telephone mode.
- ▶ Enter 911 using the number keypad on the audio control unit.
- ▶ Press  button.

or

- ▶ Press  for dialing to begin.

DIALING appears in the audio display while the telephone establishes the connection.

- ▶ Wait until the emergency call center answers, then describe the emergency.

##### **Placing a “911” emergency call with the phone locked**

**i** If the mobile phone is locked, you only can make an emergency call on the mobile phone itself, without the use of the audio control unit.

### Phone book

You can save telephone numbers in the audio system's phone book.

**i** These entries are retained even if you use the audio system with another mobile phone. You should delete these entries before handing over or selling your vehicle.

### Receiving business cards (vCards)

You can import business cards (vCards) from external Bluetooth® phones into your audio system's phone book. To do this:

- Bluetooth® must be activated on the audio system and on the external Bluetooth® phone (see the operating instructions for the mobile phone).
- The external Bluetooth® phone must be able to send vCards via Bluetooth® (see the operating instructions for the mobile phone).
- The external Bluetooth® phone in the vehicle must be switched on and authorized.

**i** If you switch to a different mode while vCards are being received (e.g., press button **RADIO**), reception of vCards will be aborted.

▶ **TEL** → Tel → Receive Business Cards.

▶ Press **☺** to confirm.

▶ **To import:** Start the data transfer on the external Bluetooth® phone (“Export business cards (vCards)”, see the operating instructions for the mobile phone).

The audio system imports the data for the business cards and displays the number of business cards received.

**i** Select Back or switch to a different mode to abort reception.

▶ **To end reception:** Press **☺**.

or

▶ Press button **BACK** in the center console (▷ page 184).

### Deleting external Data

▶ **TEL** → Tel → Delete External Data.

A prompt appears asking whether the data should be deleted.

▶ Select Yes or No.

If you select Yes all personal data are then deleted from the phone book.

### Opening the phone book

▶ **TEL** → Name.

Entries in the phone book are displayed in alphabetical order. The smart speller is active and appears near the bottom of the display.

You can use the smart speller to reduce the number of entries you need to make.



### Audio system

- ▶▶▶ **Switching from the search speller to the list:** Slide  $\uparrow$   $\odot$  repeatedly or press and hold  $\odot$  until the search speller is hidden.

or

- ▶ Select **ok** .
- ▶ **Switching from the list to the search speller:** Press button **BACK** .

### Selecting an entry

#### Selecting via search speller

- ▶ Switch if necessary from the list to the search speller.
- ▶ **To switch search speller character set:** Select **...**.

Depending on the previous setting, this switches it to letters with special characters or numbers with special characters

- ▶ **To enter characters:** Slide  $\leftarrow$   $\odot$   $\rightarrow$  or rotate  $\left\{ \odot \right\}$  the audio controller to select the characters for the required entry.

The first letters you enter determine the first letters of the word you are looking for.

- ▶ Press  $\odot$  to confirm.

The first entry containing the selected initial letters is highlighted in the list. If there are a number of similar entries, the next different character is displayed.

#### Example:

In the example, the first letters of the names Fisher, Bob and Fisher, Kim are the same. The first possible distinct letter is the B or the K. Therefore, B and K are offered as possibilities.

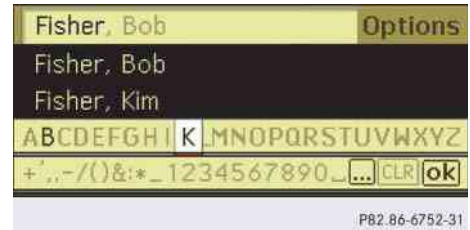

- ▶ Select the characters for the required entry one after another.

As soon as the selection has been narrowed down to a single entry, the audio system will switch to the list automatically.

- ▶ **To delete an individual character:** Select **CLR** and briefly press  $\odot$ .

or

- ▶ Press button **CLR** next to the audio controller.

After entering each character or after each deletion of a character, the closest matching entry is given at the top of the list.

► **To delete an entire entry:**

Select **CLR** and press and hold  until the entire entry has been deleted.







or

- Press and hold **CLR** until the entire entry has been deleted.

- **Ending search:** Switch from the search speller to the list.



The top list entry is highlighted automatically.

**Selecting via list**









- Switch if necessary from the search speller to the list.
- Slide    or rotate    the audio controller until the desired entry is highlighted.
- Press  to confirm and a call will be initiated.

**Displaying details on an entry**



The audio system can also fully display an abbreviated entry.

- Select entry.
- Slide   to select Options.
- Press  to confirm.
- Select Details.

A screen with the details of the selected entry appears.

- **To close details screen:** Slide   , or   , or rotate   , or press button **CLR**.

**Deleting entry**

- Select entry
- Slide   to select Options.
- Press  to confirm.
- Select Delete.

You will be prompted to confirm that you really want to delete the entry.

- Select Yes or No.

If you select Yes the actual entry is deleted from the phone book.

### Audio system

#### Call lists

The audio system displays the calls received (including missed calls) or made during phone mode in their own lists.

**i** The particular menu item can only be selected if calls have already been received or made from audio system.

The display of missed calls in the audio system display is not possible with all mobile phones.

The control system displays the list of Dialed numbers in the multifunction display.

**i** The audio system's call lists are not synchronized with the call lists on your mobile phone. If you make a call from your mobile phone and only use the audio system's hands-free device, these calls will not be listed.

#### Calling up the list

- ▶ **TEL** → Call Lists.
- ▶ Select Calls Received or Calls Dialed.

The appropriate list appears.

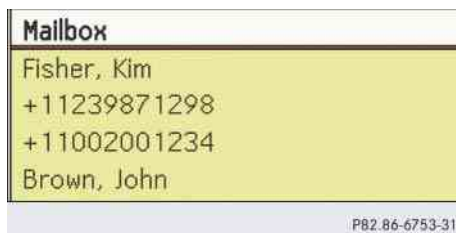

**i** If there is a symbol with a telephone receiver in front of the phone number or the name, then you have missed this call (e.g. in the highlighted line of the following figure).



- ▶ Slide or rotate the audio controller until the desired entry is highlighted.
- ▶ **Initiating call:** Press button or .
- ▶ **To close the lists:** Press button **BACK**.

#### Deleting call lists

**i** The saved call lists are retained in the audio system, even if you use the audio system with another mobile phone. For this reason you should delete any call lists before handing over or selling the vehicle.

- ▶ In the phone main menu select Call Lists.
- ▶ Select Delete Call Lists.

You will be prompted to confirm that you really want to delete the entry. The question Do you want to delete call lists appears in the display.

- ▶ Select Yes or No.
- ▶ Press to confirm.

If you select Yes both lists are deleted.

### Making calls

- ▶ Press button **TEL** on the audio control unit to call up the telephone mode.

When the mobile phone is ready for operation, the display will look like this:

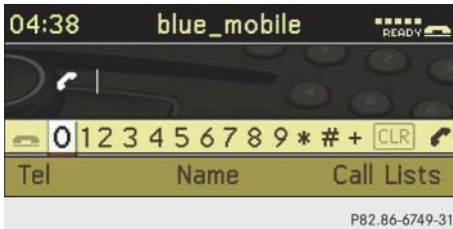

### Initiating an outgoing call

#### Entering phone number via the audio control unit

You can enter numbers and special characters via the telephone keypad.

- ▶ **Entering:** Use 0 to 9, **#** and **\*** to enter characters.

You can enter the \* character by pressing the **\*+** button once. You can enter the + character by pressing the **\*+** once and then again within approx. 1.5 seconds.









- ▶ **To delete individual digits:** Briefly press button **CLR** in the audio control unit.
  - ▶ **To delete an entire entry:** Press and hold button **CLR** until the entire entry has been deleted.
- or
- ▶ Press button .

#### Entering phone number via the audio controller

In addition to the actual menu bar, the telephone main menu features a second bar containing numbers, the number menu.

When the bar is active (highlighted), you can select elements.



- ▶ **To enter digits:** Slide   or rotate  the audio controller to select the required digit.
  - ▶ Press  to confirm.
  - ▶ Repeat the procedure, until you have selected all digits for the necessary phone number.
  - ▶ **To delete individual digits:** Slide   or rotate  to select **CLR** and briefly press .
- or
- ▶ Press **CLR** button next to the audio controller.

## Audio system

### ▶ To delete entire phone number:

Slide ←⊙→ or rotate ⏪⊙⏩ to select **CLR**, press and hold ⊕ until the phone number has been deleted.

or

▶ Press and hold **CLR** until the entire entry has been deleted.

or

▶ Press button .

▶ **To initiate a call:** Slide ←⊙→ or rotate ⏪⊙⏩ the audio controller to select .

▶ Press ⊕ to confirm.

or

▶ Press button .

### *Initiating a call to a phone book entry*

▶ **TEL** → Name.

▶ Select entry (▷ page 234).

▶ Press button  or ⊕.

### *Initiating a call to a call list entry*

▶ **TEL** → Call Lists.

▶ Select Calls Received or Calls Dialed.

The appropriate list appears.

▶ Select entry (▷ page 236).

▶ Press button  or ⊕.

### *Redialing*

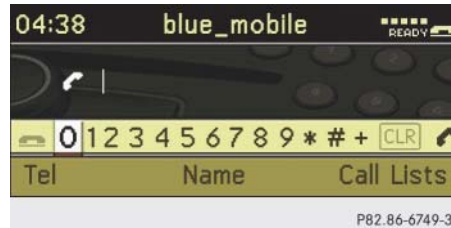

**i** In order to use the redial function, no numbers may have been entered.

▶ Press button .

or

▶ Select  and press button ⊕.

The dialed calls list appears. The call dialed last will be at the top of the list.

▶ **To select a call:** Slide ↑⊙↓ or rotate ⏪⊙⏩ the audio controller until the desired entry is highlighted.

▶ **Initiating call:** Press button ⊕ or .

### **Aborting dialing or ending a call**

▶ **TEL** →  and press button ⊕.

or

▶ Press button  on the audio control unit.

## Rejecting or accepting calls

You will be notified of an incoming call by the ringing tone and a message on the display.

**i** Depending on the mobile phone you are using, the audio system's ringing tone may differ from the one you have set on your phone. You may hear

- the ringing tone set on the mobile phone
- the audio system's preset ringing tone
- the audio system's preset ringing tone and the ringing tone set on the mobile phone.

If the caller's name and number are among the entries in the audio system's phone book and the caller has not withheld this information, it will appear on the display. If the caller withholds this information, you will see:





▶ **To accept:** Press button  on audio control unit.

or

▶ Press  on the audio controller.

▶ **To reject:** Press button  on audio control unit.

or

▶ Slide  or rotate  the audio controller to select **Reject**, and press  on the audio controller to confirm.

The call is rejected.

If you have accepted the call using the audio control unit, audio controller, or the multifunction steering wheel, the call will be conducted via the hands-free system. The volume of the call can be adjusted (▷ page 189).

Further operating functions can be found in the “Functions during a single-call” section (▷ page 240).

You can also accept a call if the audio display is showing a screen other than the telephone mode screen. After accepting the call, the display switches to the phone display. Once the call is over, the display for the previous mode will appear again.



### Audio system

#### Functions during a single call

##### Switching hands-free microphone on or off

The menu bar changes when you make or receive a call. Instead of the **Call Lists** menu item, **Mic Off** or **Mic On** will appear.

- ▶ **To switch off:** Select **Mic Off**.

The following message will flash up on the display: *The microphone is off.*

When the microphone is switched off the symbol  appears in the main area.

- ▶ **To switch on:** Select **Mic On**.

The following message will flash up on the display: *The microphone is on.*

The microphone is switched on and the symbol  disappears in the main area.

##### Sending DTMF tones

 *This function is not possible with all mobile phones.*

Answering machines or other devices can be controlled via DTMF tones, e.g. for remote query functions.

- ▶ **To transmit individual characters:** During a call select the required characters.

or

- ▶ Press the corresponding button on the audio control unit.

Every selected character is transmitted immediately.

- ▶ **Transmitting a phone number of a phone book entry as a sequence of characters:** Select **Name**.
- ▶ Select the desired phone book entry.  
The entry is transmitted immediately as a sequence of characters.
- ▶ **To switch back to call display:** Select **Back**.

## ▼ Driving systems

The driving systems of your vehicle are described on the following pages:

- Cruise control, with which the vehicle can maintain a preset speed.
- Hill start assist system which helps you to start off smoothly on a hill.

For information on the ABS, Adaptive Brake, BAS, EBP, ESP®, and 4MATIC, see “Driving safety systems” (▷ page 59).

### Cruise control

The cruise control automatically maintains the speed you set for your vehicle.

The use of the cruise control is recommended for driving at a constant speed for extended periods of time.

You can set or resume the cruise control at any speed over 20 mph (30 km/h).

The cruise control function is operated by means of the cruise control lever.

### Warning!



The cruise control is a convenience system designed to assist the driver during vehicle operation. The driver is and must always remain responsible for the vehicle's speed and for safe brake operation.

Only use the cruise control if the road, traffic, and weather conditions make it advisable to travel at a steady speed.

- The use of the cruise control can be dangerous on winding roads or in heavy traffic because conditions do not allow safe driving at a steady speed.
- The use of the cruise control can be dangerous on slippery roads. Rapid changes in tire traction can result in wheel spin and loss of control.
- Deactivate the cruise control when driving in fog.

The “Resume” function should only be operated if the driver is fully aware of the previously set speed and wishes to resume this particular preset speed.

### Warning!



The cruise control brakes automatically so that the set speed is not exceeded. The brake pedal depresses when the cruise control engages the brakes.

Keep driver's foot area clear at all times, including the area under the brake pedal. Objects stored in this area may impair pedal movement which could interfere with the braking ability of the cruise control system.

Do not place your foot under the brake pedal – your foot could become caught.

Keep in mind that the cruise control is a convenience system designed to assist the driver during vehicle operation. The driver is and must always remain responsible for the vehicle's speed and for safe brake operation.

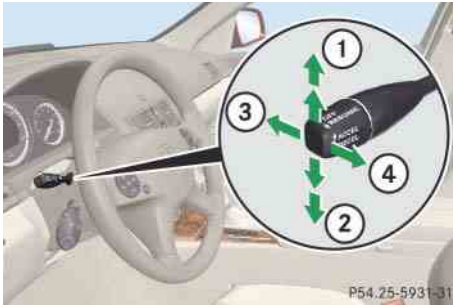

- ① Setting current or higher speed  
Adjustment in 1 mph increments (to resistance point) or 5 mph increments (past resistance point)  
(Canada: 1 km/h or 10 km/h)
- ② Setting current or lower speed  
Adjustment in 1 mph increments (to resistance point) or 5 mph increments (past resistance point)  
(Canada: 1 km/h or 10 km/h)
- ③ Cancel cruise control
- ④ Resume to last set speed

### Activating cruise control

You can activate the cruise control if the vehicle speed is above 20 mph (30 km/h).

In the following cases you cannot activate the cruise control:

- when you brake
- the vehicle is secured with the parking brake
- Vehicles with automatic transmission\*: when the gear selector lever is set to position **P**, **R**, or **N**
- when ESP® is switched off

**i** *The vehicle speed displayed in the speedometer can briefly vary from the speed setting for the cruise control system.*

### Setting current speed

- ▶ Accelerate or decelerate to the desired speed.
- ▶ Briefly lift the cruise control lever in direction of arrow ① or depress in direction of arrow ②.

The current speed is set.

- ▶ Remove your foot from the accelerator pedal.

The cruise control is activated.

- The last set speed appears in the multifunction display for approximately 5 seconds.
- The corresponding speedometer segments from the selected speed to the vehicle maximum speed in the multifunction display are illuminated.



### ① Segments

**i** On uphill grades, the cruise control may not be able to maintain the set speed. Once the grade eases, the set speed will be resumed.

On downhill grades, the cruise control maintains the set speed by braking with the vehicle's braking system. In addition, on longer downhill grades the automatic transmission\* will downshift automatically.

**i** Vehicles with manual transmission: If you depress the clutch pedal when shifting into another gear, the engine speed may increase.

- Always drive at sufficient, but not excessive, engine speed.
- Shift gear in a timely manner.
- Avoid shifting down more than one gear if at all possible.

### Canceling cruise control

There are several ways to cancel the cruise control:

- ▶ Step on the brake pedal.

The cruise control is canceled. The last speed set is stored for later use.

or

- ▶ Briefly push the cruise control lever in direction of arrow ③ (▷ page 242).

The cruise control is canceled. The last speed set is stored for later use.

**i** The last stored set speed is canceled when the engine is turned off.

**i** The cruise control switches off automatically and the segments in the multifunction display go out when

- you step on the brake pedal.
- you press the parking brake pedal.

The cruise control switches off automatically, the segments in the multifunction display go out and an acoustic warning sounds when

- the vehicle speed is below 20 mph (30 km/h).
- the ESP® is in operation or switched off with the ESP® switch (▷ page 63).
- Vehicles with manual transmission: you engage neutral or depress the clutch pedal for more than 6 seconds during shifting into another gear.
- Vehicles with automatic transmission\*: you move the gear selector lever to position **N** while driving.

Observe additional messages in the multifunction display that may appear.

**!** *Vehicles with automatic transmission\*:* Setting the automatic transmission to **N** while driving cancels the cruise control. However, the gear selector lever should not be moved to position **N** while driving except to coast when the vehicle is in danger of skidding (e.g. on icy roads).

**i** *Depressing the accelerator pedal does not deactivate the cruise control. After brief acceleration (e.g. for passing), the cruise control will resume the last speed set.*

#### Setting a higher speed

##### Warning!



If you increase the set vehicle speed, keep in mind that it may take a brief moment until the vehicle has reached the set speed.

Increase the set vehicle speed to a value that the prevailing road conditions and legal speed limits permit. Otherwise, sudden and unexpected acceleration of the vehicle could cause an accident and/or serious injury to you and others.

You can increase the set speed in two ways.

#### **Adjustment in 1 mph (Canada: 1 km/h) increments**

**i** *The set speed value is increased in 1 mph (Canada: 1 km/h) increments each time you lift the cruise control lever up to the resistance point.*

▶ Briefly lift the cruise control lever to the resistance point in direction of arrow ① (▷ page 242).

▶ Release the cruise control lever.

The vehicle set speed increases in increments 1 mph (Canada: 1 km/h).

#### **Adjustment in 5 mph (Canada: 10 km/h) increments**

**i** *The set speed value is increased in 5 mph (Canada: 10 km/h) increments each time you lift the cruise control lever up past the resistance point.*

▶ Briefly lift the cruise control lever past the resistance point in direction of arrow ① (▷ page 242).

▶ Release the cruise control lever.

The vehicle set speed increases in increments 5 mph (Canada: 10 km/h).

**i** *The new speed is set and the vehicle will accelerate. Keep in mind that it may take a brief moment until the vehicle has reached the set speed.*

## Setting a lower speed

### Warning!



If you decrease the set vehicle speed, keep in mind that it may take a brief moment until the vehicle has reached the set speed.

Decelerate the set vehicle speed to a value that the prevailing road conditions and legal speed limits permit. Otherwise, sudden and unexpected deceleration of the vehicle could cause an accident and/or serious injury to you and others.

You can reduce the set speed in two ways.

**i** When you use the cruise control lever to decelerate, the brake system will automatically brake the vehicle if the engine's braking power does not brake the vehicle sufficiently.

### Adjustment in 1 mph (Canada: 1 km/h) increments

**i** The set speed value is decreased in 1 mph (Canada: 1 km/h) increments each time you press the cruise control lever down to the resistance point.

- ▶ Briefly press the cruise control lever down to the resistance point in direction of arrow ② (▷ page 242).
- ▶ Release the cruise control lever.

The vehicle set speed decreases in increments 1 mph (Canada: 1 km/h).

### Adjustment in 5 mph (Canada: 10 km/h) increments

**i** The set speed value is decreased in 5 mph (Canada: 10 km/h) increments each time you press the cruise control lever down past the resistance point.

- ▶ Briefly press the cruise control lever down past the resistance point in direction of arrow ② (▷ page 242).

- ▶ Release the cruise control lever.

The vehicle set speed decreases in increments 5 mph (Canada: 10 km/h).

**i** The new speed is set and the vehicle will decelerate. Keep in mind that it may take a brief moment until the vehicle has reached the set speed.

### Setting to last stored speed ("Resume" function)

### Warning!



The set speed stored in memory should only be set again if prevailing road conditions permit. Possible acceleration or deceleration differences arising from returning to the preset speed could cause an accident and/or serious injury to you and others.

### Driving systems

- ▶ Briefly pull the cruise control lever in the direction of arrow ④ (▷ page 242).

The cruise control resumes to the last set speed or if no speed is stored, it will set and store the current speed.

- ▶ Remove your foot from the accelerator pedal.

The last set speed appears in the multi-function display for approximately 5 seconds, and the corresponding speedometer segments from the selected speed to the vehicle maximum speed are illuminated.

- i** *The last stored set speed is deleted when the engine is turned off.*

### Hill start assist system

#### Warning!



The hill start assist system is not designed to function as a parking brake and does not prevent the vehicle from moving when parked on an incline.

Always depress the parking brake in addition to shifting to park position **P**.

On uphill grades with a gradient angle of more than 5°, the hill start assist system maintains the pressure in the brake system for approximately 1 second after you have released the brake pedal. Therefore, you can start off smoothly without the vehicle moving immediately after releasing the brake pedal.

- ▶ Depress the brake pedal
- ▶ **Manual transmission:** Engage forward or reverse gear.

- ▶ Slowly release the clutch pedal, removing your foot from the brake pedal at the same time, and carefully depress the accelerator pedal.

- ▶ **Automatic transmission\*:** Move the gear selector lever to position **D** or **R**.
- ▶ Remove your foot from the brake pedal and carefully depress the accelerator pedal.

- i** *When you remove your foot from the accelerator, the vehicle will remain stationary for approx. 1 second.*

The hill start assist system is inactive

- when starting off on a level road or downhill grades
- vehicles with automatic transmission\* with the gear selector lever in position **N**
- with the parking brake depressed
- if the ESP® has switched off due to a malfunction

▼ Air vents

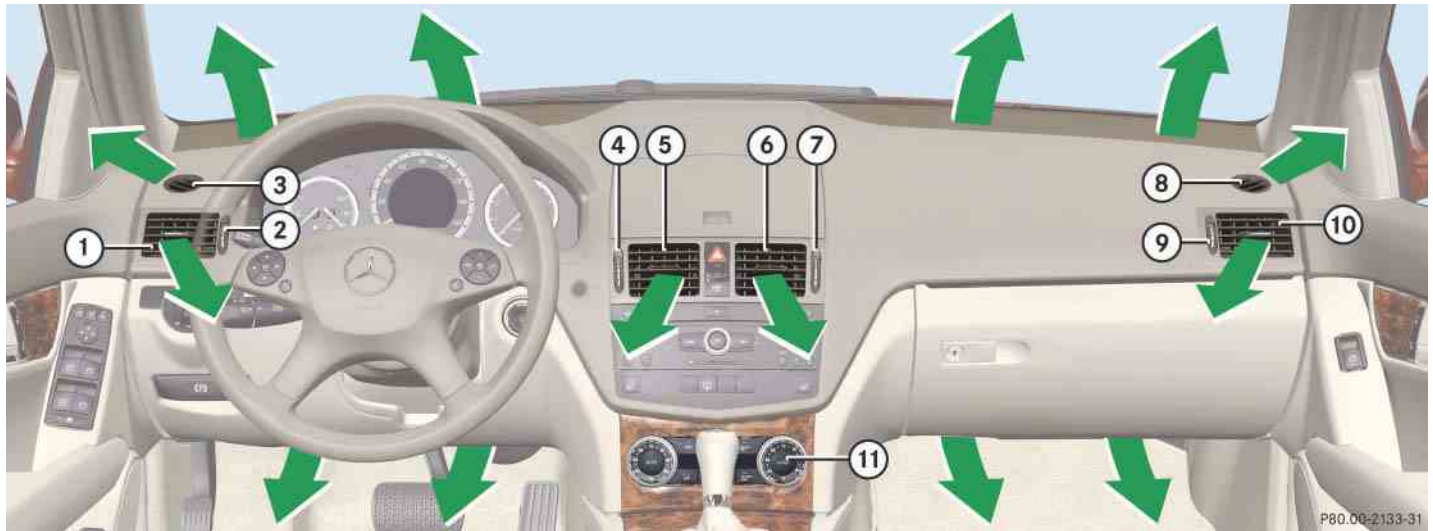

P80.00-2133-31

Item
① Left side air vent, adjustable
② Thumbwheel for air volume control for left side air vent
③ Left side defroster vent, fixed
④ Thumbwheel for air volume control for left center air vent

Item
⑤ Left center air vent, adjustable
⑥ Right center air vent, adjustable
⑦ Thumbwheel for air volume control for right center air vent
⑧ Right side defroster vent, fixed

Item
⑨ Thumbwheel for air volume control for right side air vent
⑩ Right side air vent, adjustable
⑪ Climate control panel



### Air vents

#### Warning!



When operating the automatic climate control, the air that enters the passenger compartment through the air vents can be very hot or very cold (depending on the set temperature). This may cause burns or frostbite to unprotected skin in the immediate area of the air vents.

Always keep sufficient distance between unprotected parts of the body and the air vents. If necessary, use the air distribution adjustment (▷ page 248) to direct the air to air vents in the vehicle interior that are not in the immediate area of unprotected skin.

Please comply with the following instructions in order for the automatic climate control to function optimally:

- Keep the air intake grille in front of the windshield free of snow, leaves, sticks, and any other debris.
- Always keep all air vents and grilles in the passenger compartment free from obstruction.

#### Opening and closing air vents

**i** For draft-free ventilation, move the sliders for the center air vents and side air vents to the middle position.

#### Center air vents

- ▶ **Opening/closing:** Turn thumbwheels ④ and ⑦ upward or downward.
- ▶ **Adjusting air distribution:** Push the slide for the left center air vent ⑤ or right center air vent ⑥ to the left, right, up, or down.

The air flow is directed in the corresponding direction.

### Side air vents

► **Opening/closing:**

Turn thumbwheels ② and/or ⑨ upward or downward.

- **Adjusting air distribution:** Push the slide for the left side air vent ① or right side air vent ⑩ to the left, right, up, or down.

The air flow is directed in the corresponding direction.

### Rear center console air vents

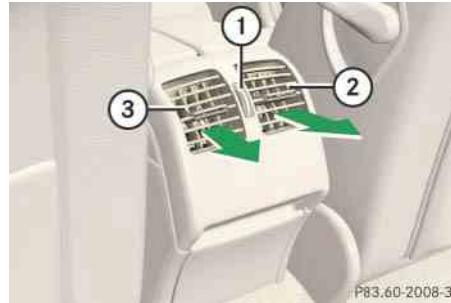

- ① Thumbwheel for air volume control for rear passenger compartment air vents.
- ② Right center air vent, adjustable
- ③ Left center air vent, adjustable

- **Opening/closing:** Turn thumbwheel ① upward or downward.
- **Adjusting air distribution:** Push the slide for the left center air vent ③ or right center vent ② to the left, right, up, or down.

The air flow is directed in the corresponding direction.

## Dual-zone automatic climate control



P83.40-3755-31

Dual-zone automatic climate control panel

Item	
①	Temperature control, driver's side
②	<b>OFF</b> Automatic climate control on/off
③	<b>MAX COOL</b> on/off (USA only) <b>MONO</b> Adopting driver's side settings for all zones (Canada only)

Item	
④	<b>A/C</b> AC cooling on/off
⑤	<b>MAX</b> Front defroster
⑥	Temperature control, passenger side
⑦	<b>REAR</b> Air recirculation
⑧	<b>REAR</b> Rear window defroster
⑨	<b>REAR</b> Increasing air volume

Item	
⑩	<b>REAR</b> Decreasing air volume
⑪	Display
⑫	<b>REAR</b> Air distribution
⑬	<b>AUTO</b> Air distribution and air volume (automatic mode)

## Dual-zone automatic climate control

The dual-zone automatic climate control is operational whenever the engine is running. You can operate the dual-zone automatic climate control system in either the automatic or manual mode. The system cools or heats the interior depending on the selected interior temperature and the current outside temperature.

It can only function optimally when you are driving with the windows and the tilt/sliding sunroof/panorama sunroof\* closed.

**Warning!**

When operating the climate control, the air that enters the passenger compartment through the air vents can be very hot or very cold (depending on the set temperature). This may cause burns or frostbite on unprotected skin in the immediate area of the air vents. Always keep sufficient distance between unprotected parts of the body and the air vents. If necessary, use the air distribution control (▷ page 248) to direct the air to air vents in the vehicle interior that are not in the immediate area of unprotected skin.

Nearly all dust particles, pollutants and odors are filtered out before outside air enters the passenger compartment through the air distribution system.

**Warning!**

Severe conditions (e.g. strong air pollution) may require replacement of the filter before its scheduled interval. A clogged filter will reduce the air volume to the interior and the windows could fog up, impairing visibility and endangering you and others. Have a clogged filter replaced as soon as possible at an authorized Mercedes-Benz Center.

The air conditioning will not engage (no cooling) if the **A/C** mode is deactivated (▷ page 258).

**Warning!**

Follow the recommended settings for heating and cooling given on the following pages. Otherwise the windows could fog up, impairing visibility and endangering you and others.

### Dual-zone automatic climate control

**i** Keep the air intake grille in front of the windshield free of snow and debris.

Do not obstruct air flow by placing objects on the air flow-through exhaust slots below the rear window.

**i** If the vehicle interior is hot, ventilate the interior before driving off, see “Summer opening feature” (▷ page 123). The climate control will then adjust the interior temperature to the set value much faster.

#### Deactivating the climate control system

##### Warning!



When the climate control is switched off, the outside air supply and circulation are also switched off. Only choose this setting for a short time. Otherwise the windows could fog up, impairing visibility and endangering you and others.

- ▶ **Deactivating:** Press button **OFF** (▷ page 250).  
The indicator lamp in the button comes on.
- ▶ **Reactivating:** Make sure the ignition is switched on.

- ▶ Press button **OFF** (▷ page 250) again.  
The indicator lamp in the button goes out. The previous settings are once again in effect.

or,

- ▶ Press button **AUTO** (▷ page 250) while the engine is running.  
The indicator lamp in the button comes on. The air volume and air distribution are adjusted automatically.

## Dual-zone automatic climate control

### Operating the climate control system in automatic mode

**i** When operating the climate control system in automatic mode, you will only rarely need to adjust the temperature, air volume and air distribution.

In automatic mode, cooling with dehumidify is switched on. This function can be switched off if necessary (▷ page 258).

- ▶ **Activating:** Press button **AUTO** (▷ page 250) while the engine is running.

The indicator lamp in the button comes on. The air volume and air distribution are adjusted automatically.

- ▶ Use temperature controls ① and ⑥ (▷ page 250) to separately adjust the air temperature on each side of the passenger compartment.

The temperature of the vehicle interior is adjusted automatically.

- ▶ **Deactivating:** Press button **AUTO** (▷ page 250) again.

The indicator lamp in the button goes out. The automatic operation of air volume and air distribution switches off. The symbols of air distribution and air volume appear in display ⑪.

- ▶ Adjust air distribution (▷ page 254).
- ▶ Adjust air volume (▷ page 254).

### Setting the temperature

Use temperature controls ① and ⑥ (▷ page 250) to separately adjust the air temperature on each side of the passenger compartment. You should raise or lower the temperature setting in small increments, preferably starting at 72°F (22°C). The climate control will adjust to the set temperature as fast as possible.

- ▶ **Increasing:** Turn temperature control ① and/or ⑥ (▷ page 250) slightly clockwise.



The climate control system will correspondingly adjust the interior air temperature.



- ▶ **Decreasing:** Turn temperature control ① and/or ⑥ (▷ page 250) slightly counterclockwise.

The climate control system will correspondingly adjust the interior air temperature.



### Dual-zone automatic climate control

#### Adjusting air distribution

Use button  (▷ page 250) to adjust the air distribution manually. The following symbols are shown in display :

Symbol	Function
	Directs air to the windshield and the side defroster vents
	Directs air through the center, side and rear passenger compartment air vents
	Directs air to the footwells



 You can also select a position between two symbols with button .

- ▶ Press button  (▷ page 250) repeatedly until you have selected the desired setting and the corresponding symbol is shown in display .

The indicator lamp in button **AUTO** goes out. The automatic air distribution is switched off. The air distribution is controlled according to the selected control setting.

#### Adjusting air volume

Seven blower speeds are available.

- ▶ Press button  to decrease or  (▷ page 250) to increase air volume to the desired level.

The indicator lamp in button **AUTO** (▷ page 250) goes out.

The air volume is adjusted corresponding to the set blower speed. The automatic air distribution remains switched on.

#### Using driver-side settings for all temperature zones (Canada only)

You can use the settings of the driver's side, such as temperature, air volume and air distribution, for all temperature zones.

- ▶ **Activating:** Press button **MONO** (▷ page 250).

The indicator lamp in the button comes on.

The driver-side settings are used for all temperature zones.

- ▶ **Deactivating:** Press button **MONO** (▷ page 250) again.

The indicator lamp in the button goes out.

## Front defroster

You can use this setting to defrost the windshield, for example if it is iced up. You can also defog the windshield and the side windows.

**i** *Keep this setting selected only until the windshield or the side windows are clear again.*

► **Activating:** Press button  (▷ page 250).

The indicator lamp in the button comes on.

The air conditioning switches automatically to the following functions:



- cooling on to dehumidify
- most efficient blower speed and heating power, depending on outside temperature
- air flows onto the windshield and the front side windows
- the air recirculation mode is switched off

**i** *You can adjust the temperature and the air volume when the front defroster is switched on.*

► **Deactivating:** Press button  (▷ page 250) again.

The indicator lamp in the button goes out. Defrosting is turned off.

The previous settings are once again in effect.

**i** *To switch defrosting off, you can also press button **OFF**, **AUTO**, ,  or temperature controls ① and ⑥ (▷ page 250).*



**i** *The cooling remains switched on.*

## Windshield fogged on the outside

**i** *Keep this setting selected only until the windshield is clear again.*

► Switch the windshield wipers on (▷ page 117).

If the automatic mode of the climate control is switched off:

► Press button  (▷ page 250) repeatedly until one of the following symbols appears in display ⑪:  or  (▷ page 250).



### Dual-zone automatic climate control

#### Maximum cooling MAX COOL (USA only)

You can use this setting to provide the fastest possible cooling of the vehicle interior (when windows and tilt/sliding sunroof or tilt/sliding panel\* are closed).

- ▶ **Activating:** Press button ③ (▷ page 250).

The indicator lamp in the button comes on.

The air conditioning switches automatically to the following functions:

- maximum cooling
- maximum blowing power
- the air recirculation mode is switched on

- ▶ **Deactivating:** Press button ③ (▷ page 250) again.

The indicator lamp in the button goes out. The previous settings are once again in effect.

- ▶ **i** To switch the maximum cooling function off, you can also press button **OFF**, **AUTO** or **MAX** (▷ page 250).

#### Rear window defroster

##### Warning!



Any accumulation of snow and ice should be removed from the rear window before driving. Visibility could otherwise be impaired, endangering you and others.

- ▶ **Activating:** Switch on the ignition.
- ▶ Press button **REAR** (▷ page 250).

The indicator lamp in the button comes on.

- ▶ **!** The rear window defroster uses a large amount of power. To keep battery drain to a minimum, switch off the defroster as soon as the rear window is clear.

## Dual-zone automatic climate control

- **Deactivating:** Press button  (▷ page 250).

The indicator lamp in the button goes out.

**i** *The rear window defroster is automatically deactivated after some time of operation depending on the outside temperature.*

**i** *If the rear window defroster switches off too soon and the indicator lamp goes out, this indicates that too many electrical consumers are operating simultaneously and the load on the battery is reducing available voltage. The system responds automatically by deactivating the rear window defroster.*

### Air recirculation mode

Switch to air recirculation mode to prevent unpleasant odors from entering the vehicle from the outside (e.g. before driving through a tunnel). This setting cuts off the intake of outside air and recirculates the air in the passenger compartment.

#### Warning!



Fogged windows impair visibility, endangering you and others. If the windows begin to fog on the inside, switching off the air recirculation mode immediately should clear interior window fogging. If interior window fogging persists, make sure the air conditioning (▷ page 258) is activated, or press button .

- **Activating:** Press button  (▷ page 250).

The indicator lamp in the button comes on.

**i** *The air recirculation mode is activated automatically at high outside temperatures.*

*The indicator lamp in button  is not lit when the air recirculation mode is automatically switched on.*

*A quantity of outside air is added after approximately 30 minutes.*

- **Deactivating:** Press button  (▷ page 250) again.

The indicator lamp in the button goes out.

**i** *The air recirculation mode is deactivated automatically:*

- *after 5 minutes if the outside temperature is below approximately 41 °F (5 °C)*
- *after 5 minutes if the air conditioning is turned off*
- *after 30 minutes if the outside temperature is above approximately 41 °F (5 °C)*

### Dual-zone automatic climate control

#### Air conditioning

The cooling function, only operational when the engine is running, cools the vehicle interior down to the selected temperature. The cooling function also dehumidifies the air in the vehicle interior, thus preventing the windows from fogging up.

#### Warning!



If you turn off the cooling function, the vehicle will not be cooled when weather conditions are warm and the interior air is not dried. The windows can fog up more quickly. Window fogging may impair visibility and endanger you and others.

**i** Condensation may drip out from underneath the vehicle. This is normal and not an indication of a malfunction.

It is possible to deactivate the air conditioning (cooling) function of the climate control system. The air in the vehicle will then no longer be cooled or dehumidified.

▶ **Deactivating:** Press button  (▷ page 250).

The indicator lamp in the button goes out.

The cooling function switches off after a short delay.

Moist air can fog up the windows. You can dehumidify the air with the air conditioning.

▶ **Activating:** Press button  (▷ page 250) again.

The indicator lamp in the button comes on.

The air conditioning uses the refrigerant R134a. This refrigerant is free of CFCs which are harmful to the ozone layer.

**!** *If the air conditioning cannot be turned on again, this indicates that the air conditioning is losing refrigerant. The compressor has turned itself off.*

*Have the air conditioning checked at the nearest authorized Mercedes-Benz Center.*

3-zone automatic climate control\* (Canada only)

▼ 3-zone automatic climate control\* (Canada only)



P83.40-3801-31

3-zone automatic climate control panel, front

Item	
①	Temperature control, driver's side
②	<b>AUTO</b> Air distribution and air volume (automatic mode)
③	<b>OFF</b> Automatic climate control on/off
④	<b>MONO</b> Adopting driver's side settings for all zones

Item	
⑤	<b>A/C</b> AC cooling on/off
⑥	<b>REST</b> Residual engine heat/ventilation
⑦	<b>MAX</b> Front defroster
⑧	Temperature control, passenger side
⑨	<b>REAR</b> Rear window defroster

Item	
⑩	Air distribution, passenger side
⑪	Increasing air volume
⑫	Decreasing air volume
⑬	Display
⑭	Air distribution, driver's side
⑮	Air recirculation

### 3-zone automatic climate control\* (Canada only)

The 3-zone automatic climate control is operational whenever the engine is running. You can operate the 3-zone automatic climate control system in either the automatic or manual mode. The system cools or heats the interior depending on the selected interior temperature and the current outside temperature.

It can only function optimally when you are driving with the windows and the tilt/sliding sunroof/panorama sunroof\* closed.

#### Warning!



When operating the climate control, the air that enters the passenger compartment through the air vents can be very hot or very cold (depending on the set temperature). This may cause burns or frostbite on unprotected skin in the immediate area of the air vents. Always keep sufficient distance between unprotected parts of the body and the air vents. If necessary, use the air

distribution control (▷ page 248) to direct the air to air vents in the vehicle interior that are not in the immediate area of unprotected skin.

It is possible to completely deactivate the 3-zone automatic climate control system (▷ page 261).

Nearly all dust particles, pollutants and odors are filtered out before outside air enters the passenger compartment through the air distribution system.

#### Warning!



Severe conditions (e.g. strong air pollution) may require replacement of the filter before its scheduled interval. A clogged filter will reduce the air volume to the interior and the windows could fog up, impairing visibility and endangering you and others. Have a clogged filter replaced as soon as possible at an authorized Mercedes-Benz Center.

The air conditioning will not engage (no cooling) if the **A/C** mode is deactivated (▷ page 267).

#### Warning!



Follow the recommended settings for heating and cooling given on the following pages. Otherwise the windows could fog up, impairing visibility and endangering you and others.

**i** Keep the air intake grille in front of the windshield free of snow and debris.

*Do not obstruct air flow by placing objects on the air flow-through exhaust slots below the rear window.*

**i** If the vehicle interior is hot, ventilate the interior before driving off, see “Summer opening feature” (▷ page 123). The climate control will then adjust the interior temperature to the set value much faster.

## 3-zone automatic climate control\* (Canada only)

## Deactivating climate control system

## Warning!



When the climate control is switched off, the outside air supply and circulation are also switched off. Only choose this setting for a short time. Otherwise the windows could fog up, impairing visibility and endangering you and others.

- ▶ **Deactivating:** Press button **OFF** (▷ page 259).

The indicator lamp in the button comes on.

- ▶ **Reactivating:** Make sure the ignition is switched on.

- ▶ Press button **OFF** (▷ page 259) again.

The indicator lamp in the button goes out. The previous settings are once again in effect.

or,

- ▶ Press button **AUTO** (▷ page 259) while the engine is running.

The indicator lamp in the button comes on. The air volume and air distribution are adjusted automatically.

## Operating climate control system in automatic mode

**i** When operating the climate control system in automatic mode, you will only rarely need to adjust the temperature, air volume and air distribution.

*In automatic mode, cooling with dehumidify is switched on. This function can be switched off if necessary.*

- ▶ **Activating:** Press button **AUTO** (▷ page 259) while the engine is running.

The indicator lamp in the button comes on. The air volume and air distribution are adjusted automatically.

- ▶ Use temperature controls ① and ⑧ (▷ page 259) to separately adjust the air temperature on each side of the passenger compartment.

The temperature of the vehicle interior is adjusted automatically.

### 3-zone automatic climate control\* (Canada only)

- ▶ **Deactivating:** Press button **AUTO** (▷ page 259) again.

The indicator lamp in the button goes out. The automatic operation of air volume and air distribution switches off. The symbols of air distribution and air volume appear in display ⑬.

- ▶ Adjust air distribution (▷ page 263).
- ▶ Adjust air volume (▷ page 263).

#### Setting the temperature

Use temperature controls ① and/or ⑧ (▷ page 259) to separately adjust the air temperature on each side of the passenger compartment. You should raise or lower the temperature setting in small increments, preferably starting at 72°F (22°C). The climate control will adjust to the set temperature as fast as possible.

- ▶ **Increasing:** Turn temperature control ① and/or ⑧ (▷ page 259) slightly clockwise.

The climate control system will correspondingly adjust the interior air temperature.

**i** You can also adjust the temperature in the rear passenger compartment (▷ page 268).

**i** If you turn the temperature control fully clockwise for one side of the vehicle, you are increasing the temperature for the other side of the vehicle as well.





- ▶ **Decreasing:** Turn temperature control ① and/or ⑧ (▷ page 259) slightly counterclockwise.



The climate control system will correspondingly adjust the interior air temperature.

**i** If you turn the temperature control fully counterclockwise for one side of the vehicle, you are decreasing the temperature for the other side of the vehicle as well.



## 3-zone automatic climate control\* (Canada only)

## Adjusting air distribution

Use right  and/or left  button  (▷ page 259) to adjust the air distribution manually for each side of the passenger compartment. The following symbols are shown in display :



Symbol	Function
	Directs air to the windshield and the side defroster vents
	Directs air through the center, side and rear passenger compartment air vents
	Directs air to the footwells

 You can also select a position between two symbols with button .



- ▶ Press buttons  (▷ page 259) repeatedly until you have selected the desired setting and the corresponding symbol is shown in display .

The indicator lamp in button **AUTO** goes out. The automatic air distribution is switched off. The air distribution is controlled according to the selected control setting.

## Adjusting air volume

Use button **AUTO** (▷ page 259) for automatic mode or button  (▷ page 259) or  (▷ page 259) to adjust air volume manually.

Seven blower speeds are available for each side of the passenger compartment.

- ▶ Press button  to decrease, or button  to increase air volume to the desired level.

The indicator lamp in button **AUTO** (▷ page 259) goes out.

The air volume is adjusted corresponding to the set blower speed. The automatic air distribution remains switched on.

## Using driver-side settings for all temperature zones

You can use the settings of the driver's side, such as temperature, air volume and air distribution, for all temperature zones.

- ▶ Press button **MONO** (▷ page 259).

The indicator lamp in the button comes on.

The driver-side settings are used for all temperature zones.



### 3-zone automatic climate control\* (Canada only)

#### Front defroster

You can use this setting to defrost the windshield, for example if it is iced up. You can also defog the windshield and the side windows.

**i** Keep this setting selected only until the windshield is clear again.

▶ **Activating:** Press button  (▷ page 259).

The indicator lamp in the button comes on.

The air conditioning switches automatically to the following functions:



- cooling on to dehumidify
- most efficient blower speed and heating power, depending on outside temperature
- air flows onto the windshield and the front side windows
- the air recirculation mode is switched off

**i** You can adjust the air distribution when the front defroster is switched on.

▶ **Deactivating:** Press button  (▷ page 259) again.

The indicator lamp in the button goes out. Defrosting is turned off.

The previous settings are once again in effect.

**i** To switch defrosting off, you can also press button **OFF**, **AUTO**, ,  or temperature controls ① and ⑧ (▷ page 259).



**i** The cooling remains switched on.

#### Windshield fogged on the outside

**i** Keep this setting selected only until the windshield is clear again.

▶ Switch the windshield wipers on (▷ page 118).

If the automatic mode of the climate control is switched off:

▶ Press right ⑩ and/or left ⑭ air distribution button  (▷ page 259) repeatedly until one of the following symbols appears in display ⑬:  or  (▷ page 259).

## 3-zone automatic climate control\* (Canada only)

## Rear window defroster

- ▶ **Activating:** Switch on the ignition.
- ▶ Press button  (> page 259).

The indicator lamp in the button comes on.

**!** *The rear window defroster uses a large amount of power. To keep battery drain to a minimum, switch off the defroster as soon as the rear window is clear.*

- ▶ **Deactivating:** Press button  (> page 259).

The indicator lamp in the button goes out.

**i** *The rear window defroster is automatically deactivated after some time of operation depending on the outside temperature.*

**Warning!**

Any accumulation of snow and ice should be removed from the rear window before driving. Visibility could otherwise be impaired, endangering you and others.

**i** *If the rear window defroster switches off too soon and the indicator lamp goes out, this indicates that too many electrical consumers are operating simultaneously and the load on the battery is reducing available voltage. The system responds automatically by deactivating the rear window defroster.*

## Air recirculation mode

Switch to air recirculation mode to prevent unpleasant odors from entering the vehicle from the outside (e.g. before driving through a tunnel). This setting cuts off the intake of outside air and recirculates the air in the passenger compartment.

**Warning!**

Fogged windows impair visibility, endangering you and others. If the windows begin to fog on the inside, switching off the air recirculation mode immediately should clear interior window fogging. If interior window fogging persists, make sure the air conditioning (> page 267) is activated, or press button .

### 3-zone automatic climate control\* (Canada only)

- ▶ **Activating:** Press button  (▷ page 259).

The indicator lamp in the button comes on.

**i** *The air recirculation mode is activated automatically at high outside temperatures.*

The indicator lamp on button  is not lit when the air recirculation mode is automatically switched on.

A quantity of outside air is added after approximately 30 minutes.

- ▶ **Deactivating:** Press button  (▷ page 259) again.

The indicator lamp in the button goes out.

**i** *The air recirculation mode is deactivated automatically:*

- after 5 minutes if the outside temperature is below approximately 7°C (45°F)
- after 5 minutes if the air conditioning is turned off
- after 30 minutes if the outside temperature is above approximately 5°C (41°F)

### Residual engine heat and ventilation

With the engine switched off, it is possible to continue to heat or ventilate the interior for approximately 30 minutes. This feature makes use of the residual heat produced by the engine.

**i** *If you switch on the residual heat function when outside temperatures are high, only the ventilation will be switched on.*

**i** *Regardless of the selected air volume, the blower operates at low speed when heating. In case of ventilation the blower operates at higher speed.*

**i** *How long the system will provide heating depends on*

- the coolant temperature
- the temperature set by the operator

- ▶ **Activating:** Switch off the ignition.

- ▶ Press button  (▷ page 259).

The indicator lamp in the button comes on.

- ▶ **Deactivating:** Press button  (▷ page 259) again.

The indicator lamp in the button goes out.

**i** *The residual heat is automatically turned off:*

- when the ignition is switched on
- after approximately 30 minutes
- if the battery voltage drops
- if the coolant temperature is too low

## 3-zone automatic climate control\* (Canada only)

**Air conditioning**

The cooling function, is only operational when the engine is running, cools the vehicle interior down to the selected temperature. The cooling function also dehumidifies the air in the vehicle interior, thus preventing the windows from fogging up.

 *Condensation may drip out from underneath the vehicle. This is normal and not an indication of a malfunction.*

**Warning!**

If you turn off the cooling function, the vehicle will not be cooled when weather conditions are warm. The windows can fog up more quickly. Window fogging may impair visibility and endanger you and others.

It is possible to deactivate the air conditioning (cooling) function of the climate control system. The air in the vehicle will then no longer be cooled or dehumidified.

► **Deactivating:** Press button  (▷ page 250).

The indicator lamp in the button goes out.

The cooling function switches off after a short delay.

Moist air can fog up the windows. You can dehumidify the air with the air conditioning.

► **Activating:** Press button  (▷ page 250) again.

The indicator lamp in the button comes on.

The air conditioning uses the refrigerant R134a. This refrigerant is free of CFCs which are harmful to the ozone layer.

 *If the air conditioning cannot be turned on again, this indicates that the air conditioning is losing refrigerant. The compressor has turned itself off.*

*Have the air conditioning checked at the nearest authorized Mercedes-Benz Center.*

### 3-zone automatic climate control\* (Canada only)

#### Rear climate control

#### Warning!



Follow the recommended settings for heating and cooling as given in the instructions for the front 3-zone automatic climate control (▷ page 259). Otherwise the windows could fog up, impairing visibility for the driver and endangering you and others.

The rear climate control panel is located in the rear center console.

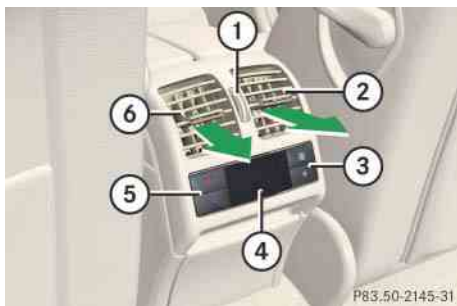

	Item
①	Decreasing/increasing air volume for rear center air vents
②	Right rear center air vent, adjustable
③	Decreasing/increasing air volume for rear center air vents
④	Display
⑤	Temperature control
⑥	Left rear center air vent, adjustable

**i** At low outside temperatures or if you have switched off the cooling function, you cannot cool the rear passenger compartment.

#### Setting temperature



Use temperature control ⑤ to adjust the air temperature in the rear passenger compartment. You should raise or lower the temperature setting in small increments, preferably starting at 22°C (72°F). The climate control will adjust to the set temperature as fast as possible.



► **Increasing/decreasing:** Press the respective temperature control button ⑤.

The 3-zone automatic climate control system will correspondingly adjust the temperature in the rear passenger compartment.

**i** If you have switched off the cooling function with the front 3-zone automatic climate control panel, the cooling of the rear passenger compartment is also switched off. Adjusting with the rear control panel is not possible.

#### Adjusting air volume

Use button  or  (▷ page 268) to adjust the air volume.

► Press button  to decrease, or button  to increase air volume to the desired level.

The air volume is adjusted correspondingly to the set blower speed.

▼ Trunk

**Warning!**



Make sure the trunk is closed when the engine is running and while driving. Among other dangers, such as blocked visibility, exhaust fumes may enter the vehicle interior. These fumes are damaging to your health.

**Opening trunk**

You can open the trunk if the vehicle is stationary.

A minimum height clearance of 5.9 ft (1.90 m) is required to open the trunk lid.

**!** *The trunk lid swings open upwards automatically. Always make sure there is sufficient overhead clearance.*

**i** *If the trunk does not open, it is still locked separately (▷ page 272).*

**Opening trunk from outside**

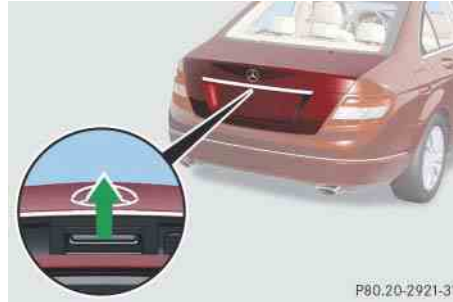

- ① Trunk lid handle
  - ▶ Press and hold button  on the SmartKey or SmartKey with KEYLESS-GO\* until trunk unlocks and begins to open.
- or
- ▶ Pull on handle ①.

In vehicles without KEYLESS-GO\*: The vehicle must be unlocked.

**Opening trunk from inside**



- ① Remote trunk opening switch
- ▶ Press switch ① until the trunk begins to open.

### Trunk

#### Closing trunk

**i** Do not place the SmartKey in the open trunk. You may lock yourself out.

**i** If the vehicle was previously centrally locked, the trunk will lock automatically after closing it. All turn signal lamps flash three times and an acoustic signal sounds three times to confirm locking.

Vehicles with KEYLESS-GO\* (Canada only): To prevent a possible inadvertent lockout, the trunk will open automatically if a SmartKey with KEYLESS-GO\* (Canada only) is recognized inside the vehicle or in the trunk.

The vehicle is only locked when the turn signals flash three times and an acoustic signal sounds three times. If you are carrying a second SmartKey with KEYLESS-GO\* (Canada only) with you, you can still lock the vehicle.

#### Closing trunk from outside manually



#### ① Handles

- ▶ Lower trunk lid by pulling firmly on handles ① or ②.
- ▶ Close the trunk with hands placed flat on the trunk lid.

#### Warning!



To prevent possible personal injury, always keep hands and fingers away from the trunk lid opening when closing the trunk. Be especially careful when small children are around.

When leaving the vehicle, always remove the SmartKey or SmartKey with KEYLESS-GO\* (Canada only) from the starter switch, take it with you, and lock the vehicle. Do not leave children unattended in the vehicle, or with access to an unlocked vehicle. A child's unsupervised access to a vehicle could result in an accident and/or serious personal injury.

### Trunk emergency release

With the emergency release button, the trunk can be opened from inside the trunk.



① Emergency release button

- ▶ Briefly press emergency release button ①.

The trunk opens.

- i** *The emergency release button unlocks and opens the trunk while the vehicle is standing still or in motion.*

Illumination of the emergency release button:

- The button will flash for 30 minutes after opening the trunk.
- The button will flash for 60 minutes after closing the trunk.

- i** *The emergency release button does not open the trunk if the vehicle battery is discharged or disconnected.*



### Trunk

#### Valet locking

**i** To deny any unauthorized person access to the trunk, e.g. when you valet park the vehicle, lock it separately with the mechanical key. Leave only the SmartKey or SmartKey with KEYLESS-GO\* (Canada only) less its mechanical key with the vehicle.



**1** Neutral position

**2** Locked

- ▶ Close the trunk (▷ page 270).
- ▶ Remove the mechanical key from the SmartKey (▷ page 424).
- ▶ Insert the mechanical key in the trunk lid lock.
- ▶ Turn the mechanical key clockwise to position **2** to lock the trunk.
- ▶ Remove the mechanical key from the trunk lid lock.

The trunk remains locked even when the vehicle is centrally unlocked.

**i** You can only cancel the separate trunk locking mode by means of the mechanical key.

- ▶ Insert the mechanical key in the trunk lid lock.
- ▶ Turn the mechanical key counterclockwise to neutral position **1** to unlock the trunk.

You can now open the trunk (▷ page 269).

## ▼ Power tilt/sliding sunroof

### Opening and closing power tilt/sliding sunroof

#### Warning!



When closing the tilt/sliding sunroof, make sure there is no danger of anyone being harmed by the closing procedure.

If the tilt/sliding sunroof is blocked while closing and reopens, it can be closed with greater force if you pull the switch to the resistance point in the direction indicated by arrow ③ within 2 seconds.

If the tilt/sliding sunroof is blocked again and reopens, you can close it with deactivated obstruction sensor function by pulling the switch again to the resistance point in the direction indicated by arrow ③ within 2 seconds.

When closing the tilt/sliding sunroof with the obstruction sensor function deactivated, make sure no one can become trapped, as this could result in serious or fatal injuries.

The opening/closing procedure of the tilt/sliding sunroof can be immediately halted by releasing the switch or, if the switch was moved past the resistance point and released, by moving the switch in any direction.

The tilt/sliding sunroof is made out of glass. In the event of an accident, the glass may shatter. This may result in an opening in the roof.

In a vehicle rollover, occupants not wearing their seat belts or not wearing them properly may be thrown out of the opening. Such an opening also presents a potential for injury for occupants wearing their seat belts properly as entire body parts or portions of them may protrude from the passenger compartment.

When leaving the vehicle, always remove the SmartKey or SmartKey with KEYLESS-GO\* from the starter switch, take it with you, and lock the vehicle. Do not leave children unattended in the vehicle, or with access to an unlocked vehicle. A child's unsupervised access to a vehicle could result in an accident and/or serious personal injury.

**!** *To avoid damaging the seals, do not transport any objects with sharp edges which can stick out of the tilt/sliding sunroof.*

*Do not open the tilt/sliding sunroof if there is snow or ice on the roof, as this could result in malfunctions.*

**!** *Please keep in mind that weather conditions can sometimes change rapidly. Make sure to close the tilt/sliding sunroof when leaving the vehicle. If water enters the vehicle interior, vehicle electronics could be damaged which is not covered by the Mercedes-Benz Limited Warranty.*

### Power tilt/sliding sunroof

**i** When the tilt/sliding sunroof is open, resonance noises may result in addition to the usual wind noises. They are caused by minimal pressure changes in the passenger compartment. To reduce or eliminate these noises, change the position of the tilt/sliding sunroof or open a side window slightly.

**i** You can also open or close the tilt/sliding sunroof using the SmartKey, see “Summer opening feature” (▷ page 123) and “Convenience closing feature” (▷ page 124).

**i** With the SmartKey in starter switch position **0** or removed from the starter switch, the tilt/sliding sunroof can be operated

- until you open the driver's or passenger door
- for up to approximately 5 minutes



- ① Push up to raise sunroof at rear
- ② Push back to slide sunroof open
- ③ Pull down to close the sunroof

With the sunroof closed or tilted open, a screen can be slid into the roof opening to help provide shade. When sliding the sunroof open, the screen will also retract.



#### Screen

- ▶ Switch on the ignition.
- ▶ To open, close, raise or lower, move the switch to resistance point in the required direction ① to ③ until the tilt/sliding sunroof has reached the desired position.

- ▶ **Express-operation:** To open, close, raise or lower, move the switch past the resistance point in the required direction ① to ③ and release.

The tilt/sliding sunroof opens or closes completely.

- ▶ **Stopping during Express-opening/closing:** Move the switch in any direction.

**i** *If the movement of the tilt/sliding sunroof is blocked during the closing procedure, the sunroof will stop and reopen slightly.*

### Synchronizing

The tilt/sliding sunroof must be synchronized

- after the tilt/sliding sunroof has been closed manually
- if the tilt/sliding sunroof can only be opened with a jerking motion
- after a malfunction

**!** *Do not open the tilt/sliding sunroof completely if it is not aligned. Otherwise you could damage the tilt/sliding sunroof.*

- ▶ Switch on the ignition (▷ page 82).
- ▶ Press and hold the sunroof switch in the direction of arrow ① until the tilt/sliding sunroof is fully raised at the rear.
- ▶ Keep holding the sunroof switch in the direction of arrow ① for approximately 1 second.
- ▶ Check the Express-operation feature (▷ page 275).

If the tilt/sliding sunroof opens completely, the sunroof is synchronized. Otherwise repeat the above steps.

### Panorama roof with power tilt/sliding panel\*

#### Roller sunblinds

The roller sunblinds are designed to protect you from excessive sunlight streaming in through the panorama roof with power tilt/sliding panel.

The front roller sunblind only operates with the tilt/sliding panel closed. The front and rear roller sunblind cannot be operated individually.

#### Warning!



When extending/retracting the roller sunblinds, make sure no one is in danger of being injured by the closing procedure. The extending/retracting of the roller sunblinds can be immediately halted by releasing the switch or, if the switch was pressed past the resistance point and released, by pressing the switch in any direction.

- ▶ Switch on the ignition.

#### Operating roller sunblinds

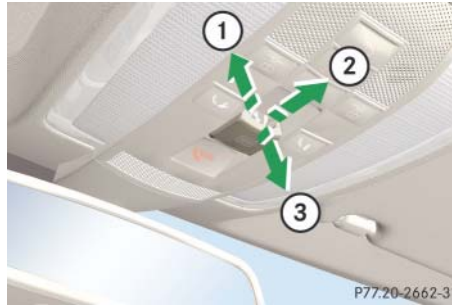

#### Roof panel switch

- ① Extend front roller sunblinds
  - ② Extend rear roller sunblinds
  - ③ Retract front roller sunblinds
- ▶ **Extending or retracting:** Move the roof panel switch to the resistance point in the required direction of arrow ①, ② or ③ until the roller sunblinds have reached their desired position.

- ▶ **Express-extending:** Move the roof panel switch past the resistance point in direction of arrow ① or ② and release.

The roller sunblinds extend completely.

- ▶ **Stopping during Express-extending:** Move the roof panel switch in any direction.

## Panorama roof with power tilt/sliding panel\*

## Opening and closing panorama roof with power tilt/sliding panel

**Warning!**

When opening or closing the tilt/sliding panel, make sure there is no danger of anyone being harmed by the opening or closing procedure.

The opening procedure of the tilt/sliding panel can be immediately halted by releasing the switch or, if the switch was moved past the resistance point and released, by moving the switch in any direction.

The closing procedure of the tilt/sliding panel can be immediately halted by releasing the switch.

The panorama roof with power tilt/sliding panel is made out of glass. In the event of an accident, the glass may shatter. This may result in an opening in the roof.

In a vehicle rollover, occupants not wearing their seat belts or not wearing them properly may be thrown out of the opening.

Such an opening also presents a potential for injury for occupants wearing their seat belts properly as entire body parts or portions of them may protrude from the passenger compartment.

When leaving the vehicle, always remove the SmartKey or SmartKey with KEYLESS-GO\* from the starter switch, take it with you, and lock the vehicle. Do not leave children unattended in the vehicle, or with access to an unlocked vehicle. A child's unsupervised access to a vehicle could result in an accident and/or serious personal injury.

**!** *To avoid damaging the seals, do not transport any objects with sharp edges which can stick out of the tilt/sliding panel.*

*Do not open the tilt/sliding panel if there is snow or ice on the roof, as this could result in malfunctions.*

**!** *Please keep in mind that weather conditions can sometimes change rapidly. Make sure to close the tilt/sliding panel when leaving the vehicle. If water enters the vehicle interior, vehicle electronics could be damaged which is not covered by the Mercedes-Benz Limited Warranty.*

**i** *When the panorama roof with power tilt/sliding panel is open, resonance noises may result in addition to the usual wind noises. They are caused by minimal pressure changes in the passenger compartment. To reduce or eliminate these noises, change the position of the panorama roof with power tilt/sliding panel or open a side window slightly.*

**i** *You can also open or close the tilt/sliding panel using the SmartKey, see "Summer opening feature" (▷ page 123) and "Convenience closing feature" (▷ page 124).*

The tilt/sliding panel only operates with the roller sunblinds extended.



### Panorama roof with power tilt/sliding panel\*

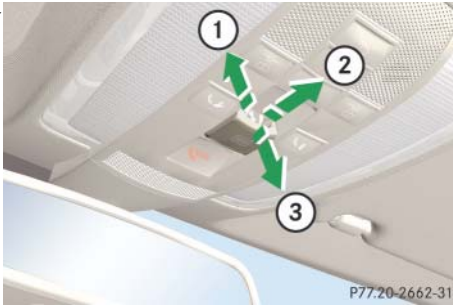

#### Roof panel switch

- ① Push up to raise at the rear
- ② Push back to open
- ③ Pull down to close

- ▶ Switch on the ignition.
- ▶ To open, close, raise, or lower the tilt/sliding panel, move the roof panel switch to resistance point in the required direction of arrows ① to ③.

Release the roof panel switch when the tilt/sliding panel has reached the desired position.

**i** If the front roller sunblind is retracted while being raised, it will extend first.

- ▶ **Express-opening:** Move the roof panel switch past the resistance point in direction of arrow ① and release.

The tilt/sliding panel opens completely.

- ▶ **Express-raising:** Move the roof panel switch past the resistance point in direction of arrow ③ and release.

The tilt/sliding panel raises completely.

- ▶ **Stopping during Express-operation:** Move the roof panel switch in any direction.

**i** You cannot automatically close and lower the panorama roof with power tilt/sliding panel.

### Synchronizing

The tilt/sliding panel and front roller sunblinds must be synchronized

- after the tilt/sliding panel has been closed manually
- after a malfunction
- if the panorama roof with power tilt/sliding panel can only be opened with a jerking motion

## Panorama roof with power tilt/sliding panel\*

## Tilt/sliding panel and roller sunblind

- ▶ Switch on the ignition.

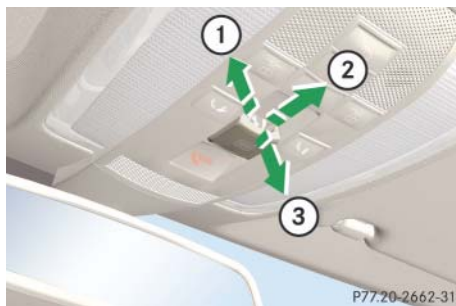

- ① Push up to raise at the rear
- ② Push back to open
- ③ Pull down to close

- ▶ Move and hold the roof panel switch in direction of arrow ③ until the roller sunblinds are fully retracted.
- ▶ Keep holding the roof panel switch in direction of arrow ③ for approximately 1 second.

- ▶ Move and hold the roof panel switch in direction of arrow ② until the roller sunblinds are fully extended.
- ▶ Move and hold the roof panel switch in direction of arrow ② until the tilt/sliding panel is opened approximately 4 inch (10 cm).
- ▶ Move and hold the roof panel switch in direction of arrow ③ until the tilt/sliding panel is fully closed.

- ▶ Keep holding the roof panel switch in direction of arrow ③ for approximately 1 second.

- ▶ Check the Express-open feature of the tilt/sliding panel (▷ page 278).

If the tilt/sliding panel opens completely, the roof is synchronized. Otherwise repeat the above steps.



### Loading and storing

#### Roof rack\*

##### Warning!



Only use roof racks approved by Mercedes-Benz for your vehicle model to avoid damage to the vehicle.

Follow the manufacturer's installation instructions. Otherwise, an improperly attached roof rack system or its load could become detached from the vehicle.

Do not exceed the maximum roof load of 220 lb (100 kg).

Take into consideration that when the roof rack is loaded, the handling characteristics are different from those when operating the vehicles without the roof rack loaded.

**!** Load the roof rack in such a way that the vehicle cannot be damaged while driving.

Make sure

- you can fully raise tilt/sliding sunroof or the panorama roof with tilt/sliding panel\*
- you can fully open the trunk

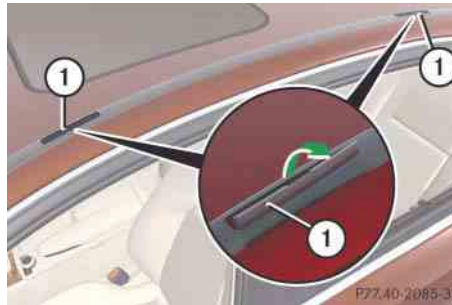

① Covers

- ▶ Flip the covers ① upward in direction of arrow.

Vehicles with panorama roof with tilt/sliding panel\*: Open the cover ① carefully in the opposite direction to that indicated by the arrow.

- ▶ Only attach the roof-rack system to the anchorage points under the covers. Observe manufacturer's instructions for installation.

### Split rear bench seat\*

To expand the cargo area, you can fold down the left and right rear seat backrests.

The two sections can be folded down separately.

#### Warning!



When expanding the luggage compartment, always fold the seat cushions fully forward.

Unless you are transporting cargo, the backrests must remain properly locked in the upright position.

In an accident, during hard braking or sudden maneuvers, loose items will be thrown around inside the vehicle, and cause injury to vehicle occupants unless the items are securely fastened in the vehicle.

### Folding the backrest forward

The release handles ① is located in the trunk.



① Release handle

- ▶ Open the trunk.
- ▶ Pull on left and/or right release handle ①.
- ▶ Fully retract the head restraints (▷ page 89).
- ▶ If necessary, pull the driver's and/or front-passenger seat forward.



② Rear seat backrests

- ▶ Fold rear seat backrests ② forward.

### Loading and storing

#### Setting up rear seat backrest



- ① Rear seat backrests
- ▶ Fold backrest ① rearward until it engages.
- ▶ Check for secure locking by pushing and pulling on the backrest.

**!** Take care not to clamp the seat belt.

#### Warning!



Always lock backrest in its upright position when rear seat bench is occupied, or the extended trunk compartment is not in use. Check for secure locking by pushing and pulling on the backrest.

In an accident, during hard braking or sudden maneuvers, loose items will be thrown around inside the vehicle, and cause injury to vehicle occupants unless the items are securely fastened in the vehicle.

To help avoid personal injury during a collision or sudden maneuver, exercise care when transporting cargo.

**i** To prevent unauthorized persons from access to the trunk, always lock backrest in its upright position.

#### Loading instructions

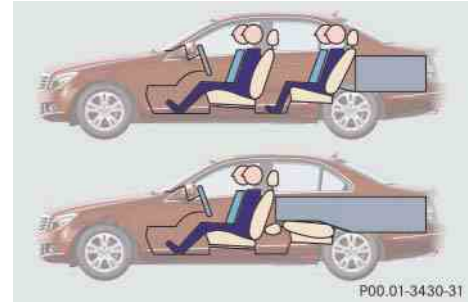

The total load weight including vehicle occupants and luggage/cargo should not exceed the load limit or vehicle capacity weight as indicated on the corresponding placard located on the driver's door B-pillar (▷ page 334).

The handling characteristics of a fully loaded vehicle depend greatly on the load distribution. It is therefore recommended to load the vehicle according to the illustrations shown, with the heaviest items being placed towards the front of the vehicle.

Always place items being carried against front or rear seat backrests, and fasten them as securely as possible.

The heaviest portion of the cargo should always be kept as low as possible since it influences the handling characteristics of the vehicle.

### Warning!



Always fasten items being carried as securely as possible using cargo tie-down hooks and fastening materials appropriate for the weight and size of the load.

In an accident, during hard braking or sudden maneuvers, loose items will be thrown around inside the vehicle and can cause injury to vehicle occupants unless the items are securely fastened in the vehicle.

To help avoid personal injury during a collision or sudden maneuver, exercise care when transporting cargo. Put luggage or cargo in the trunk if possible.

Do not pile luggage or cargo higher than the seat backs. Do not place anything on the rear-window shelf.

Never drive vehicle with trunk open. Deadly carbon monoxide (CO) gases may enter vehicle interior resulting in unconsciousness and death.

**i** *The trunk is the preferred place to carry objects.*

*The enlarged cargo area should only be used for items which do not fit in the trunk alone.*

### Storage compartments

#### Warning!



To help avoid personal injury during a collision or sudden maneuver, exercise care when storing objects in the vehicle. Put luggage or cargo in the trunk if possible. Do not pile luggage or cargo higher than the seat backs.

Parcel nets cannot secure hard or heavy objects.

Keep compartment lids closed. This will help to prevent stored objects from being thrown about and injuring vehicle occupants during

- braking
- vehicle maneuvers or
- an accident.

**i** *An overview of the storage compartments can be found on (▷ page 22).*

### Loading and storing

#### Storage compartments in the front passenger compartment

##### Glove box

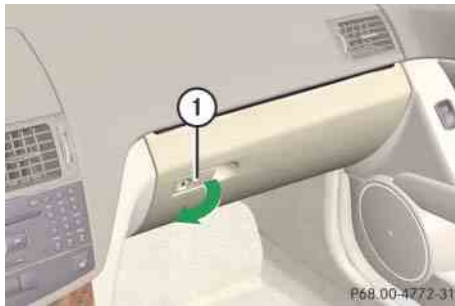

- ① Glove box lid release

The glove box can be unlocked and locked with the mechanical key (▷ page 424).

- ▶ **Opening:** Pull glove box lid release ①.
- ▶ **Closing:** Push the lid up until it engaged.



- 1 Unlocking glove box
- 2 Locking glove box

- ▶ **Locking:** Insert the mechanical key into the glove box lock and turn it clockwise to position 2.
- ▶ **Unlocking:** Insert the mechanical key into the glove box lock and turn it counterclockwise to position 1.

#### Storage compartments in the front armrest

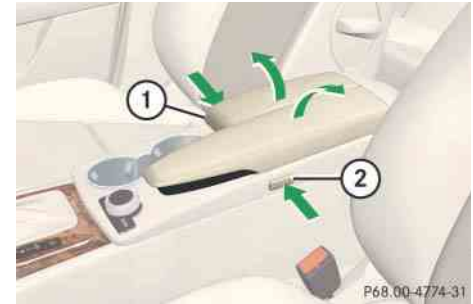

- ① Right button for storage compartments
- ② Left button for large storage compartments

- ▶ **Opening small and large storage compartment:** Press button ① or ② the armrests opens automatically to the left and right side.

**i** *There is a small and a large storage compartment located underneath the left armrest. The small storage compartment can be removed for the purpose of emptying.*

- ▶ **Closing small or large storage compartment:** Swing the left or right armrest backward until it engage.

### *Parcel net in front passenger footwell*

#### **Warning!**



The parcel net is intended for storing light-weight items only.

Heavy objects, objects with sharp edges or fragile objects may not be transported in the parcel net. In an accident, during hard braking, or sudden maneuvers, they could be injury to vehicle occupants.

The parcel net cannot protect transported goods in the event of an accident.

A small convenience parcel net is located in the front passenger footwell. It is for small and light items, such as road maps, mail, etc.

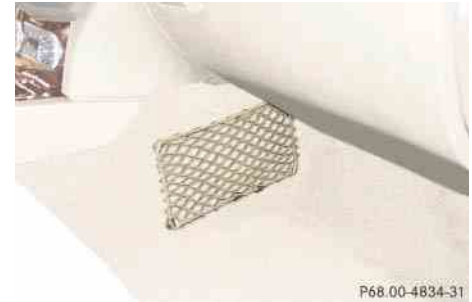

### Loading and storing

#### Storage compartments in rear passenger compartment

##### *Armrest with integrated storage compartment*

❗ Before storing the armrest in the backrest, close the storage compartment cover.

❗ Do not sit on or lean your body weight against the armrest when it is folded down, as you could otherwise damage it.



① Release catch

- ▶ **Opening:** Pull down the armrest.
- ▶ Pull release catch ① and swing the cover upward in direction of arrow.

#### Storage pockets

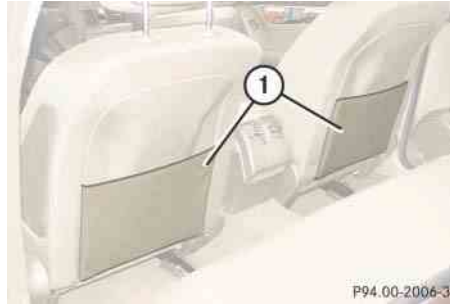

Storage pockets ① are located on the back of the front seats.

#### Warning!



The storage pocket is intended for storing light-weight items only.

Heavy objects, objects with sharp edges or fragile objects may not be transported in the storage pocket. In an accident, during hard braking, or sudden maneuvers, they could be thrown around inside the vehicle and cause injury to vehicle occupants.

The storage pocket cannot protect transported goods in the event of an accident.

## Cup holders

### Warning!



In order to help prevent spilling liquids on vehicle occupants and/or vehicle equipment, only use containers that fit into the cup holder. Use lids on open containers and do not fill containers to a height where the contents, especially hot liquids, could spill during braking, vehicle maneuvers, or in an accident. Liquids spilled on vehicle occupants may cause serious personal injury. Liquids spilled on vehicle equipment may cause damage not covered by the Mercedes-Benz Limited Warranty.

When not in use, keep the cup holders closed. An open cup holder may cause injury to you or others when contacted during braking, vehicle maneuvers, or in an accident.

Keep in mind that objects placed in the cup holder may come loose during braking, vehicle maneuvers, or in an accident and be thrown around in the vehicle interior. Objects thrown around in the vehicle interior may cause an accident and/or serious personal injury.

### Cup holder in front center console



① Cup holder

### Cup holder in rear center armrest

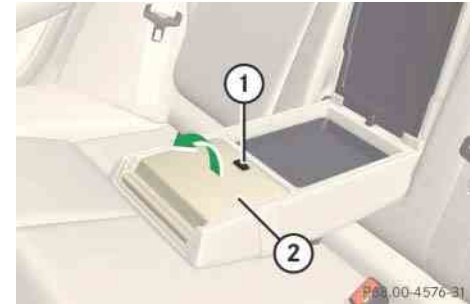

① Release button

② Cup holder

- ▶ **Opening:** Pull down the armrest.
- ▶ Pull the release catch and swing the armrest storage compartment cover upward.
- ▶ Press release button ①.
- ▶ Cup holder ② swing out and open automatically.

**i** You can now close the armrest storage compartment.



### Loading and storing

- ▶ **Closing:** Open the armrest storage compartment.
- ▶ Swing cup holder ② backward until it engaged.

### Trunk

---

#### Retaining hooks

Two hooks are located on the upper edge of the trunk and can be used to attach cargo items such as bags.



Use the hooks to secure light weight items only. The maximum permissible weight per hook is 9 lb (4 kg).

**!** *Do not use the retaining hooks to tie down cargo.*

#### Parcel net in trunk

There is a parcel net on the left trunk side walls to secure loads.

The parcel net is intended for storing light-weight items only. The parcel net cannot protect transported goods in the event of an accident.

▼ Useful features

Sun visors

**Warning!**



Do not use the vanity mirror while driving.

Keep the vanity mirrors in the sun visors closed while vehicle is in motion. Reflected glare can endanger you and others.

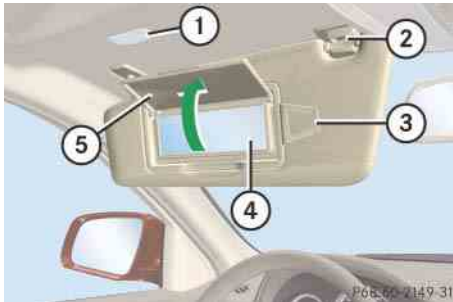

- ① Vanity mirror lamp
- ② Mounting
- ③ Document holder
- ④ Vanity mirror
- ⑤ Vanity mirror cover

**Glare from front**

- ▶ Swing sun visor down when you experience glare.

**Glare from front and sides**

- ▶ **!** Close vanity mirror cover ⑤ (if open) before you disengage sun visor from the mounting ② and pivot it to the side.

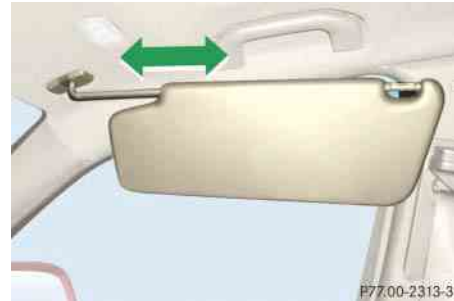

- ▶ Disengage sun visor from the mounting ②.
- ▶ Pivot sun visor to the side.  
The sun visors are extendable.
- ▶ Adjust the sun visor by pushing or pulling in direction of arrow.

**Vanity mirror in sun visor**

- ▶ To use the illuminated vanity mirror, lift up vanity mirror cover ⑤.

Vanity mirror lamp ① comes on.

- ▶ **i** If you disengage the sun visor from mounting ② with vanity mirror cover ⑤ open, vanity mirror lamp ① will switch off.

**Document holder**

You can use the plastic tab of document holder ③ to hold admission tickets, parking passes, or similar items in place.

### Useful features

#### Rear window sunshade\*

The switch is located in the center console.



#### ① Rear window sunshade switch

**!** Make sure the movement of the rear window sunshade is not restricted by objects on the rear window shelf. Otherwise, the sunshade or the objects could be damaged.

- ▶ Switch on the ignition.

Always raise the sunshade fully for its support against the window frame.

- ▶ **Raising:** Press switch ① briefly.

The sunshade is raised completely.

- ▶ **Stopping the raising procedure:**

Press switch ① again.

The sunshade stops.

- ▶ **Lowering:** Press switch ① briefly.

The sunshade is lowered completely.

- ▶ **Stopping the lowering procedure:**

Press switch ① again.

The sunshade stops.

#### Warning!



When operating the rear window sunshade, make sure there is no danger of anyone being harmed by the raising or lowering procedure.

The raising or lowering procedure can be immediately halted by briefly pressing the switch ①.

Briefly press switch ① again to raise or lower the rear window sunshade completely.

#### Warning!



When leaving the vehicle, always remove the SmartKey or SmartKey with KEYLESS-GO\* (Canada only) from the starter switch, take it with you, and lock the vehicle. Do not leave children unattended in the vehicle, or with access to an unlocked vehicle. Unsupervised use of vehicle equipment may cause an accident and/or serious personal injury.

## Ashtrays

### Center console ashtray

#### Warning!



Remove ashtray only with vehicle standing still. Depress the parking brake to secure vehicle from movement.

Move gear selector lever to position **P** (manual transmission: second gear). With the automatic transmission\* set to **P** (manual transmission: second gear), turn off the engine.

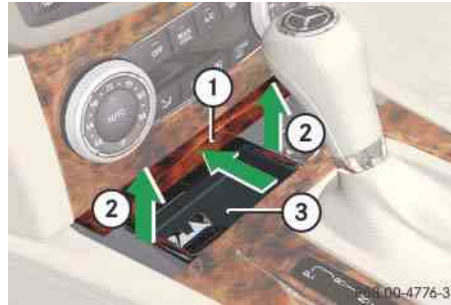

- ① Cover plate
- ② Remove insert
- ③ Ashtray

► **Opening:** Press cover plate ① forward until it engaged.

► **Removing the insert:** Grab the insert on the grooved side and pull it up and out in the direction indicated by the arrow ②.

► **Reinstalling ashtray insert:** Install the insert by pushing it back into the frame until it engages.

► **Closing:** Tap the front of the cover plate ①.

The cover will retract and the ashtray will close.

### Useful features

#### Rear seat ashtray

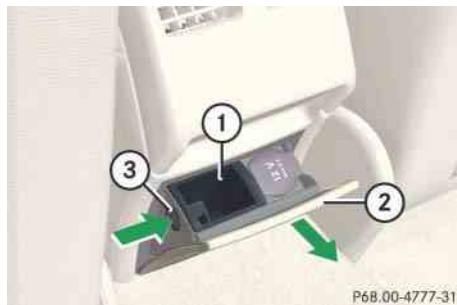

- ① Ashtray insert
- ② Cover
- ③ Button

- ▶ **Opening:** Pull at top of cover ②.
- ▶ **Removing ashtray insert:** Push button ③ to disengage ashtray insert ① and remove it.
- ▶ **Reinstalling ashtray insert:** Push the ashtray insert ① down into the retainer until it engages.
- ▶ Push at top of cover ② to close ashtray.

#### Cigarette lighter

##### Warning!



Never touch the heating element or sides of the cigarette lighter; they are extremely hot. Hold the knob only.

Make sure any children traveling with you do not injure themselves or start a fire with the hot cigarette lighter.

When leaving the vehicle, always remove the SmartKey or SmartKey with KEYLESS-GO\* (Canada only) from the starter switch, take it with you, and lock the vehicle. Do not leave children unattended in the vehicle, or with access to an unlocked vehicle.

A child's unsupervised access to a vehicle could result in an accident and/or serious personal injury.

- ▶ Switch on the ignition.



- ① Cover
- ② Cigarette lighter

- ▶ Press cover plate ① forward until it engages.
- ▶ Push in cigarette lighter ②.  
The cigarette lighter will pop out automatically when hot.

- ▶ Tap the front of the cover plate ①.

The cover will retract and the ashtray will close.

**!** *The lighter socket can accommodate 12V DC electrical accessories (up to a maximum of 85 W) designed for use with the standard “cigarette lighter” plug type. Keep in mind, however, that connecting accessories to the lighter socket (for example extensive connecting and disconnecting, or using plugs that do not fit properly) can damage the lighter socket. With the socket damaged, the lighter may no longer be able to be placed in the heating (pushed-in) position, or the lighter may pop out too early with the lighter not hot enough.*

*To help avoid damaging the cigarette lighter socket, we recommend connecting 12V DC electrical accessories designed for use with the standard “cigarette lighter” plug type to the 12V power outlet (▷ page 293) in your vehicle whenever possible.*

### Power outlet in the glove box



#### ① Power outlet

- ▶ Switch on the ignition.
- ▶ Open the glove box (▷ page 284).
- ▶ Flip cover from power outlet ① to the right and insert electrical plug (cigarette lighter type).

**i** *The power outlet ① can be used to accommodate electrical consumers (e.g. air pump, auxiliary lamps) up to a maximum of 180 W.*

### Power outlet in the rear passenger compartment

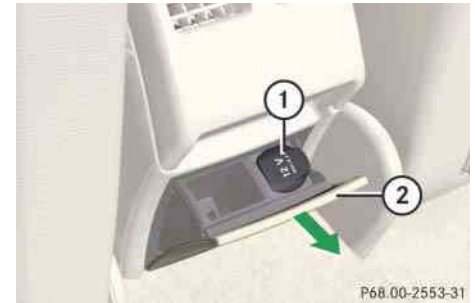

#### ① Power outlet

#### ② Cover

- ▶ Switch on the ignition.
- ▶ Pull at top of cover ②.
- ▶ Flip cover from power outlet ① to the left and insert electrical plug (cigarette lighter type).

**i** *The power outlet ① can be used to accommodate electrical consumers (e.g. air pump, auxiliary lamps) up to a maximum of 180 W.*

### Useful features

#### Floormats\*

##### Warning!



Whenever you are using floormats, make sure there is enough clearance and that the floormats are securely fastened.

Floormats should always be securely fastened using the eyelets and the retainer pins.

Before driving off, check that the floormats are securely in place and adjust them if necessary. A loose floormat could slip and hinder proper functioning of the pedals.

Do not place several floormats on top of each other as this may impair pedal movement.

**i** To install or remove the floormat more easily, move the driver's seat or front passenger seat as far to the rear as possible (▷ page 85).

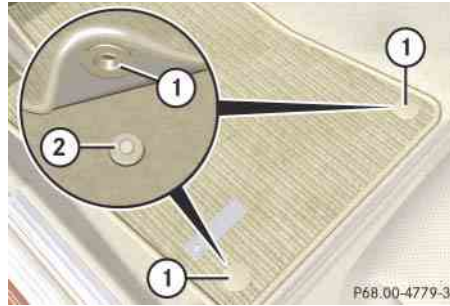

- ① Eyelet
- ② Retainer pin

#### Removing

- ▶ Pull floormat off of retainer pins ②.
- ▶ Remove the floormat.

#### Installing

- ▶ Lay down the floormat in the respective footwell.
- ▶ Press the floormat eyelets ① onto retainer pins ②.

## Tele Aid\*

**!** *The initial activation of the Tele Aid system may only be performed by completing the subscriber agreement and placing an acquaintance call using the Information button\* . Failure to complete either of these steps will result in a system that is not activated.*

*If you have any questions regarding activation, please call the Response Center at 1-800-756-9018 (in the USA) or 1-888-923-8367 (in Canada).*

### The Tele Aid system



(Telematic Alarm Identification on Demand)



The Tele Aid system consists of three types of response:



- automatic and manual emergency
- Roadside Assistance, and
- information

The Tele Aid system is operational providing that the vehicle's battery is charged, properly connected, not damaged and telephone phone and GPS coverage are available.

**i** *The Tele Aid system utilizes the telephone network for communication and the GPS (Global Positioning System) satellites for vehicle location. If either of these signals are unavailable, the Tele Aid system may not function and if this occurs, assistance must be summoned by other means.*

The speaker volume of a Tele Aid call can be adjusted when using the volume control on the multifunction steering wheel. To raise, press button  and to lower, press button  or use the audio system rotary control button (> page 189).

- ▶ To activate, press the SOS button, the Roadside Assistance button\*  or the Information button\* , depending on the type of response required.



**i** *The SOS button, the Roadside Assistance button\* , and the Information button\*  are located in the overhead control panel (> page 31).*

Shortly after the completion of your Tele Aid acquaintance call, you will receive a user ID and password. By visiting [www.mbusa.com](http://www.mbusa.com) and selecting "Tele Aid" (USA only), you will have access to account information, remote door unlock and more.





### Useful features

#### System self-check

Initially, after switching on the ignition, malfunctions are detected and indicated. If a malfunction is detected, the indicator lamps in the SOS button, the Roadside Assistance button\*  and the Information button\*  stay on longer than 10 seconds or do not come on. The message **Tele Aid not activated** or **Tele Aid inoperative** appears in the multifunction display.

#### Warning!



If the indicator lamps in the SOS button, in the Roadside Assistance button\*  and/or in the Information button\*  do not come on during the system self-check, or if any of these indicators remain illuminated continuously in red and/or the message **Tele Aid not activated** or **Tele Aid inoperative** is displayed in the multifunction display after the system self-check, a malfunction in the system has been detected.

If a malfunction is indicated as outlined above, the system may not operate as expected. Have the system checked at the nearest Mercedes-Benz Center as soon as possible.

#### Emergency calls

An emergency call is initiated automatically following an accident in which the emergency tensioning devices (ETDs) or air bags deploy.

An emergency call can also be initiated manually by opening the cover next to the interior rear view mirror labeled SOS, then briefly pressing the button located under the cover. For instructions on initiating an emergency call manually (▷ page 298).

Once the emergency call is in progress, the indicator lamp in the SOS button will begin to flash. The message:

- **Connecting call** appears in the multifunction display

and the audio system is muted. When the connection is established, the message:

- **Call connected** appears in the multifunction display

All information relevant to the emergency, such as the location of the vehicle (determined by the GPS satellite location system), vehicle model, identification number and color are generated.

**i** *During the emergency call message Emergency Call Activated is displayed, operation from audio system or COMAND\* is not possible. The automatic climate control can be still adjusted using the switches on the climate control panel.*

A voice connection between the Response Center and the occupants of the vehicle will be established automatically soon after the emergency call has been initiated. The Response Center will attempt to determine more precisely the nature of the accident provided they can speak to an occupant of the vehicle.

**i** *If no vehicle occupant responds, an ambulance will be sent to the vehicle immediately.*

The Tele Aid system is available if

- it has been activated and is operational. Activation requires a subscription for monitoring services, connection, and cellular air time
- the relevant cellular phone network and GPS signals are available and pass the information on to the Response Center
- there is sufficient voltage in the vehicle batteries

**i** *Location of the vehicle on a map is only possible if the vehicle is able to receive signals from the GPS satellite network and pass the information on to the Response Center.*

### Warning!



If the indicator lamp in the SOS button is flashing continuously and there was no voice connection to the Response Center established, then the Tele Aid system could not initiate an emergency call (e.g. the relevant telephone network is not available).

The message **Call failed** appears in the multifunction display for approximately 10 seconds.

Should this occur, assistance must be summoned by other means.

**i** *During the emergency call the telephone is switched off automatically and must be switched back on to make a call.*

**i** *The “911” emergency call system is a public service. Using it without due cause is a criminal offense.*

### Useful features

#### *Initiating an emergency call manually*



- ① Cover
- ② SOS button

- ▶ Briefly press button on cover ① to open.  
Cover ① will open.
- ▶ Press SOS button ② (for longer than 2 seconds).  
The indicator lamp in SOS button ② will flash until the emergency call is concluded.
- ▶ Wait for a voice connection to the Response Center.
- ▶ Close cover ① after the emergency call is concluded.

#### **Warning!**



If you feel in any way in jeopardy when in the vehicle (e.g. smoke or fire in the vehicle, vehicle in a dangerous road location), please do not wait for voice contact after you have pressed the emergency button. Carefully leave the vehicle and move to a safe location. The Response Center will automatically contact local emergency officials with the vehicle's approximate location if they receive an automatic SOS signal and cannot make voice contact with the vehicle occupants.

### Roadside Assistance button\*

The Roadside Assistance button  is located in the overhead control panel.



#### ① Roadside Assistance button

- ▶ Press and hold Roadside Assistance button  (for longer than 2 seconds).

A call to a Mercedes-Benz Roadside Assistance dispatcher will be initiated. The button will flash while the call is in progress. The message:

- **Connecting call** appears in the multifunction display and the audio system is muted.

When the connection is established, the message:

- **Call connected** appears in the multifunction display

The Tele Aid system will transmit data generating the vehicle identification number, model, color and location (subject to availability of cellular and GPS signals).



A voice connection between the Roadside Assistance dispatcher and the occupants of the vehicle will be established.

- ▶ Describe the nature of the need for assistance.

The Mercedes-Benz Roadside Assistance dispatcher will either dispatch a qualified Mercedes-Benz technician or arrange to tow your vehicle to the nearest authorized Mercedes-Benz Center. For services such as labor and/or towing, charges may apply. Refer to the Roadside Assistance Manual for more information.

These programs are only available in the USA:

- **Sign and Drive services:** Services such as jump start, a few gallons of fuel or the replacement of a flat tire with the vehicle spare tire are obtainable.

 *The indicator lamp in the Roadside Assistance button  remains illuminated in red for approximately 10 seconds during the system self-check after switching on the ignition (together with the SOS button and the Information button\* .*

*See system self-check (▷ page 296) if the indicator lamp does not come on in red or stays on longer than approximately 10 seconds.*

*If the indicator lamp in the Roadside Assistance button  is flashing continuously and no voice connection to the Response Center was established, the Tele Aid system could not initiate a Roadside Assistance call (e.g. the relevant telephone network is not available). The message:*

- **Call failed** appears in the multifunction display for approximately 10 seconds

*Roadside Assistance calls can be terminated using the  button on the multifunction steering wheel or the respective button for ending a telephone call on the audio system or the COMAND\* head unit.*

### Useful features

#### Information button\*

The Information button  is located in the overhead control panel.



#### ① Information button

- ▶ Press and hold Information button  (for longer than 2 seconds).

A call to the Customer Assistance Center will be initiated. The button will flash while the call is in progress. The message:

- Connecting call appears in the multifunction display

and the audio system is muted.



When the connection is established, the message:

- Call connected appears in the multifunction display

The Tele Aid system will transmit data generating the vehicle identification number, model, color and location (subject to availability of cellular and GPS signals).

A voice connection between the Customer Assistance Center representative and the occupants of the vehicle will be established. Information regarding the operation of your vehicle, the nearest authorized Mercedes-Benz Center or Mercedes-Benz USA products and services is available to you.

For more details concerning the Tele Aid system, please visit [www.mbusa.com](http://www.mbusa.com) and use your ID and password (sent to you separately) to learn more (USA only).

 The indicator lamp on the Information button  remains illuminated in red for approximately 10 seconds during the system self-check after switching on the ignition (together with the SOS button and the Roadside Assistance button\* ).

See system self-check (▷ page 296) if the indicator lamp does not come on in red or stays on longer than approximately 10 seconds.

If the indicator lamp in the Information button  is flashing continuously and no voice connection to the Response Center was established, then the Tele Aid system could not initiate an Information call (e.g. the relevant telephone network is not available). The message:

- Call failed appears in the multifunction display for approximately 10 seconds

Information calls can be terminated using the  button on the multifunction steering wheel or the respective button for ending a telephone call on the audio system or the COMAND\* head unit.

**!** If the indicator lamps do not start flashing after pressing one of the buttons or remain illuminated (in red) at any time, the Tele Aid system has detected a fault or the service is not currently activated, and may not initiate a call. Contact an authorized Mercedes-Benz Center and have the system checked or contact the Response Center at 1-800-756-9018 (in the USA) or 1-888-923-8367 (in Canada) as soon as possible.

### Call priority

If other service calls such as a Roadside Assistance call or Information call are active, an emergency call is still possible. In this case, the emergency call will take priority and override all other active calls.

**i** The indicator lamp in the respective button flashes until the call is concluded. Calls can only be terminated by a Response Center or Customer Assistance Center representative except Roadside Assistance and Information calls, which can also be terminated by using the  button on the multifunction steering wheel or the respective button for ending a telephone call on the audio system or the COMAND\* head unit.

**!** If the indicator lamp continues to flash or the system does not terminate the call at all, contact the Response Center at 1-800-756-9018 (in the USA) or 1-888-923-8367 (in Canada), or Mercedes-Benz Customer Assistance at 1-800-FOR-MERCEdes (1-800-367-6372) in the USA or Customer Service at 1-800-387-0100 in Canada.

**i** When a Tele Aid call has been initiated, the audio system is muted. The optional cellular phone (if installed) switches off. If you must use this phone, the vehicle must be parked. Unplug the telephone, switch it on and place the call. The COMAND\* navigation system (if engaged) will continue to run. The multifunction display in the instrument cluster is available for use, but spoken commands are not available.

### Remote door unlock

In case you have locked your vehicle unintentionally (e.g. SmartKey inside vehicle), and the reserve SmartKey is not handy:

- ▶ Contact the Mercedes-Benz Response Center at 1-800-756-9018 (in the USA) or 1-888-923-8367 (in Canada).

You will be asked to provide your password which you provided when you completed the subscriber agreement.

OR

- ▶ Contact the Tele Aid web page via Internet using the ID and password sent to you shortly after the completion of your acquaintance call.
- ▶ Then return to your vehicle and pull the trunk lid handle for a minimum of 20 seconds until the SOS button is flashing.

The message: **Call connecting** appears in the multifunction display.

The Response Center will then unlock your vehicle with the remote door unlocking feature.

**i** The remote door unlock feature is available if the relevant telephone network is available and data connection is possible.

The SOS button will flash and the message: **Call connecting** appears in the multifunction display to indicate receipt of the door unlock command.



### Useful features

▷▷ Once the vehicle is unlocked, a Response Center specialist might attempt to establish voice contact with the vehicle occupants.

*If the trunk lid handle was pulled for more than 20 seconds before door unlock authorization was received by the Response Center, you must wait 15 minutes before pulling the trunk lid handle again.*

#### Remote door lock

If you have forgotten to lock your vehicle and are no longer near it, you can have it locked remotely through the Response Center.

The vehicle can be remotely locked within 4 days after the ignition has been switched off.

- ▶ Contact the Mercedes-Benz Response Center at 1-800-756-9018 (in the USA) or 1-888-923-8367 (in Canada).

You will be asked to provide your password which you provided when you completed the subscriber agreement.

When you are inside your vehicle the next time and switch on the ignition, the message **Tele Aid Doors locked by remote control** will appear on the multifunction display.

**i** The remote door lock feature is available if the relevant telephone network is available and data connection is possible.

#### Automatic Maintenance Call

The C-Class is equipped with a feature that considerably enhances vehicle care. Just prior to reaching a vehicle maintenance milestone, Tele Aid transmits important vehicle maintenance information that alerts your authorized Mercedes-Benz Center of required service. This is automatic and does not require driver intervention. This feature allows your preferred Mercedes-Benz Center to significantly improve the process of arranging your service appointment and ensures that your vehicle receives the best possible care.

**i** The Automatic Maintenance Call feature is available if the relevant telephone network is available and data connection is possible.

#### Stolen Vehicle Recovery services

In the event your vehicle was stolen:

- ▶ Report the incident to the police.

The police will issue a numbered incident report.

- ▶ Pass this number on to the Mercedes-Benz Response Center along with your password issued to you when you subscribed to the service.

The Response Center will then attempt to covertly contact the vehicle's Tele Aid system. Once the vehicle is located, the Response Center will contact the local law enforcement and you. The vehicle's location will only be provided to law enforcement.

**i** When the anti-theft alarm or the tow-away alarm stays on for more than 30 seconds, a call is initiated automatically to the Response Center, see "Anti-theft alarm system" (▷ page 66).

### Garage door opener\*

The integrated remote control is capable of operating up to three separately controlled devices. It provides a convenient way to replace up to three hand-held remote controls used to operate devices such as garage door openers, gate openers, or other devices compatible with HomeLink® or some other systems.

Before the integrated remote control can be used, it must be programmed to the garage door opener, gate operator or other device you wish to operate. See the following instructions for programming information.

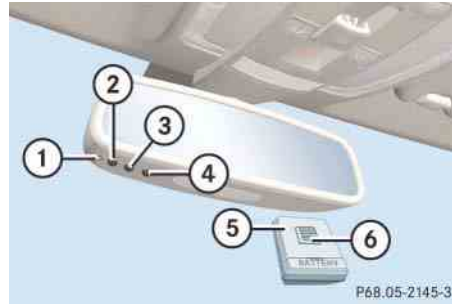

#### Interior rear view mirror with integrated remote control

- ① Indicator lamp
- ② ③ ④ Signal transmitter button

Needed for programming (not part of vehicle equipment):

- ⑤ Hand-held remote control of garage door opener, gate operator or other device
- ⑥ Hand-held remote control button

#### Warning!



Before programming the integrated remote control to a garage door opener or gate operator, make sure people and objects are out of the way of the device to prevent potential harm or damage. When programming a garage door opener, the door moves up or down. When programming a gate operator, the gate opens or closes.

Do not use the integrated remote control with any garage door opener that lacks safety stop and reverse features as required by U.S. federal safety standards (this includes any garage door opener model manufactured before April 1, 1982). A garage door that cannot detect an object – signaling the door to stop and reverse – does not meet current U.S. federal safety standards.

When programming a garage door opener, park the vehicle outside the garage.





### Useful features

- ▷▷ Do not run the engine while programming the integrated remote control. Inhalation of exhaust gas is hazardous to your health. All exhaust gas contains carbon monoxide (CO), and inhaling it can cause unconsciousness and possible death.

#### Programming integrated remote control

Step 1:

- ▶ Switch on the ignition (▷ page 82).

Step 2:

- ▶ If you have previously programmed a signal transmitter button and wish to retain its programming, proceed to step 3.

If you are programming the integrated remote control for the first time, press and hold the two outer signal transmitter buttons ② and ④ and release them only when indicator lamp ① begins to flash after approximately 20 seconds (do not hold the button for

longer than 30 seconds). This procedure erases any previous settings for all three channels and initializes the memory.

If you later wish to program a second and/or third hand-held transmitter to the remaining two signal transmitter buttons, do not repeat this step and begin directly with step 3.

Step 3:

- ▶ Hold the end of hand-held remote control ⑤ of the device you wish to train approximately 2 to 5 in (5 to 12 cm) away from the signal transmitter button (②, ③ or ④) to be programmed, while keeping indicator lamp ① in view.

Step 4:

- ▶ Using both hands, simultaneously press hand-held remote control button ⑥ and the desired signal transmitter button (②, ③ or ④). Do not release the buttons until step 5 is completed.

Indicator lamp ① will flash, first slowly and then rapidly.

**i** Indicator lamp ① flashes immediately the first time the signal transmitter button is programmed. If this button has already been programmed, the indicator lamp will only start flashing after 20 seconds.

Step 5:

- ▶ After indicator lamp ① changes from a slow to a rapidly flashing light, release the hand-held remote control button and the signal transmitter button.

Step 6:

- ▶ Press and hold the just-trained signal transmitter button (②, ③ or ④) and observe indicator lamp ①.

If indicator lamp ① stays on constantly, programming is complete and your device should activate when the respective signal transmitter button (②, ③ or ④) is pressed and released.

**i** If indicator lamp ① flashes rapidly for about 2 seconds and then turns to a constant light, continue with programming steps 8 through 12 as your garage door opener may be equipped with the “rolling code” feature.

Step 7:

- ▶ To program the remaining two signal transmitter buttons, repeat the steps above starting with step 3.

### **Rolling code programming**

To train a garage door opener (or other rolling code devices) with the rolling code feature, follow these instructions after completing the “Programming” portion (steps 1 through 6) of this text. (A second person may make the following training procedures quicker and easier.)

Step 8:

- ▶ Locate “training” button on the garage door opener motor head unit.

Exact location and color of the button may vary by garage door opener brand. Depending on manufacturer, the

“training” button may also be referred to as “learn” or “smart” button. If there is difficulty locating the transmitting button, refer to the garage door opener operator’s manual.

Step 9:

- ▶ Press the “training” button on the garage door opener motor head unit.

The “training light” is activated.

You have 30 seconds to initiate the following two steps.

Step 10:

- ▶ Return to the vehicle and firmly press, hold for 2 seconds and release the programmed signal transmitter button (②, ③ or ④).

Step 11:

- ▶ Press, hold for 2 seconds and release same signal transmitter button a second time to complete the training process.

**i** Some garage door openers (or other rolling code equipped devices) may require you to press, hold for 2 seconds and release the same signal transmitter button a third time to complete the training process.

Step 12:

- ▶ Confirm the garage door operation by pressing the programmed signal transmitter button (②, ③ or ④).

Step 13:

- ▶ To program the remaining two signal transmitter buttons, repeat the steps above starting with step 3.

### **Gate operator/Canadian programming**

Canadian radio-frequency laws require transmitter signals to “time-out” (or quit) after several seconds of transmission which may not be long enough for the integrated signal transmitter to pick up the signal during programming. Similar to this Canadian law, some U.S. gate operators are designed to “time-out” in the same manner.

### Useful features

If you live in Canada or if you are having difficulties programming a gate operator (regardless of where you live) by using the programming procedures, replace step 4 with the following:

Step 4:

- ▶ Press and hold the signal transmitter button (②, ③ or ④). Do not release this button until it has been successfully trained.
- ▶ While still holding down the signal transmitter button (②, ③ or ④), “cycle” your hand-held remote control button ⑥ as follows: Press and hold button ⑥ for 2 seconds, then release it for 2 seconds, and again press and hold it for 2 seconds. Repeat this sequence on the hand-held remote control until the frequency signal has been learned. Upon successful training, indicator lamp ① will flash slowly and then rapidly after several seconds.
- ▶ Proceed with programming step 5 and step 6 to complete.

**i** Upon completion of programming the integrated remote control, make sure you retain the hand-held remote control that came with the garage door opener, gate operator or other device. You may need it for use in other vehicles, for future programming of an integrated remote control, or simply for continued use as a hand-held remote control to operate the respective device in other situations.

#### Reprogramming a single signal transmitter button

To program a device using a signal transmitter button previously trained, follow these steps:

- ▶ Switch on the ignition (▷ page 82).
- ▶ Press and hold the desired signal transmitter button (②, ③ or ④). Do not release the button.
- ▶ Indicator lamp ① will begin to flash after 20 seconds. Without releasing the signal transmitter button, proceed with programming starting with step 3.

#### Operation of integrated remote control

- ▶ Switch on the ignition (▷ page 82).
- ▶ Select and press the appropriate integrated signal transmitter button (②, ③ or ④) to activate the remote controlled device.

The integrated remote control transmitter continues to send the signal as long as the button is pressed – up to 20 seconds.

#### Erasing integrated remote control memory

- ▶ Switch on the ignition (▷ page 82).
- ▶ Simultaneously press and hold outer signal transmitter buttons ② and ④, for approximately 20 seconds, until indicator lamp ① flashes rapidly. Do not hold for longer than 30 seconds.

The codes of all three channels are erased.

**i** If you sell your vehicle, erase the codes of all three channels.

## Programming tips

If you are having difficulty programming the integrated remote control, here are some helpful tips:

- Check the frequency of hand-held remote control ⑤ (typically located on the reverse side of the remote). The integrated remote control is compatible with radio-frequency devices operating between 280-390 MHz.
- Put a new battery in hand-held remote control ⑤. This will increase the likelihood of the hand-held remote control sending a faster and more accurate signal to the integrated remote control.
- While performing step 3, hold hand-held remote control ⑤ at different lengths and angles from the signal transmitter button (②, ③ or ④) you are programming. Attempt varying angles at the distance of 2 to 5 in (5 to 12 cm) away or the same angle at varying distances.
- If another hand-held remote control is available for the same device, try the programming steps again using that other hand-held remote control. Make sure new batteries are in the hand-held remote control before beginning the procedure.
- Straighten the antenna wire from the garage door opener assembly. This may help improve transmitting and/or receiving signals.

**i** Certain types of garage door openers are incompatible with the integrated remote control. If you should experience further difficulties with programming the integrated remote control, contact an authorized Mercedes-Benz Center, or call Mercedes-Benz Customer Assistance Center (in the USA only) at 1-800-FOR-MERCEdes, or Customer Service (in Canada) at 1-800-387-0100.

**i** USA only:  
This device complies with Part 15 of the FCC Rules. Operation is subject to the following two conditions:

- (1) This device may not cause harmful interference, and
- (2) this device must accept any interference received, including interference that may cause undesired operation.

Any unauthorized modification to this device could void the user's authority to operate the equipment.

**i** Canada only:  
This device complies with RSS-210 of Industry Canada. Operation is subject to the following two conditions:

- (1) This device may not cause interference, and
- (2) this device must accept any interference received, including interference that may cause undesired operation of the device.

Any unauthorized modification to this device could void the user's authority to operate the equipment.



**The first 1000 miles (1500 km)**

**Driving instructions**

**At the gas station**

**Engine compartment**

**Tires and wheels**

**Winter driving**

**Maintenance**

**Vehicle care**



### The first 1000 miles (1500 km)

In the “Operation” section you will find detailed information on operating, maintaining and caring for your vehicle.

The more cautiously you treat your vehicle during the break-in period, the more satisfied you will be with its performance later on.

- Drive your vehicle during the first 1000 miles (1500 km) at varying but moderate vehicle and engine speeds.
- During this period, avoid heavy loads (full throttle driving) and excessive engine speeds (no more than  $\frac{2}{3}$  of maximum rpm in each gear).
- Avoid accelerating by kick-down.
- Do not attempt to slow the vehicle down by shifting to a lower gear using the gear selector lever.
- Select gear ranges **3**, **2** or **1** only when driving at moderate speeds (for hill driving).
- Select **C** as the preferred shift program (▷ page 144) for the first 1000 miles (1500 km).

After 1000 miles (1500 km) you may gradually increase vehicle and engine speeds to the permissible maximum.

All of the above instructions, as may apply to your vehicle type, also apply when driving the first 1000 miles (1500 km) after the engine or the rear differential has been replaced.

 *Always obey applicable speed limits.*

## ▼ Driving instructions

### Drive sensibly – save fuel

---

Fuel consumption, to a great extent, depends on driving habits and operating conditions.

To save fuel you should:

- Keep tires at the recommended tire inflation pressures.
- Remove unnecessary loads.
- Remove roof rack when not in use.
- Allow engine to warm up under low load use.
- Avoid frequent acceleration and deceleration.
- Have all maintenance work performed at the intervals specified in the Maintenance Booklet and as required by the Maintenance System. Contact an authorized Mercedes-Benz Center.

Fuel consumption is also increased by driving in cold weather, in stop-and-go traffic, on short trips, and in hilly area.

### Drinking and driving

---

#### Warning!



Drinking and driving and/or taking drugs and driving are very dangerous combinations. Even a small amount of alcohol or drugs can affect your reflexes, perceptions and judgment.

The possibility of a serious or even fatal accident are greatly increased when you drink or take drugs and drive.

Do not drink or take drugs and drive or allow anyone to drive who has been drinking or taking drugs.

### Pedals

---

#### Warning!



Make sure absolutely no objects are obstructing the pedals' range of movement.

Keep the driver's footwell clear of all obstacles. If there are any floor mats or carpets in the footwell, make sure the pedals still have sufficient clearance. Otherwise this could lead to accidents or injury.

### Power assistance

---

#### Warning!



With the engine not running, there is no power assistance for the brake and steering systems. In this case, it is important to keep in mind that a considerably higher degree of effort is necessary to brake and steer the vehicle.



### Brakes

#### Warning!



After driving in heavy rain for some time without applying the brakes or through water deep enough to wet brake components, the first braking action may be somewhat reduced and increased pedal pressure may be necessary to obtain expected braking effect. Maintain a safe distance from vehicles in front.

Resting your foot on the brake pedal will cause excessive and premature wear of the brake pads.

It can also result in the brakes overheating, thereby significantly reducing their effectiveness. It may not be possible to stop the vehicle in sufficient time to avoid an accident.

**!** *Vehicles without 4MATIC:*  
Because the ESP<sup>®</sup> operates automatically, the engine and ignition must be shut off (SmartKey in starter switch position **0** or **1** or KEYLESS-GO (Canada only) start/stop button\* in position **0** or **1**) when

- the parking brake is being tested on a brake test dynamometer
- the vehicle is being towed with the front axle raised

*Active braking action through the ESP<sup>®</sup> may otherwise seriously damage the brake system.*

*For information on vehicles with 4MATIC, see "Four wheel electronic traction system (4MATIC) with the ESP<sup>®</sup>" (▷ page 65).*

To help prevent brake disk corrosion after driving on wet road surfaces (particularly salted roads), it is advisable to brake the vehicle with considerable force prior to parking. The heat generated serves to dry the brakes.

If your brake system is normally only subjected to moderate loads, you should occasionally test the effectiveness of the

brakes by applying above-normal braking pressure at higher speeds. This will also enhance the grip of the brake pads.

#### Warning!



Make sure not to endanger any other road users when carrying out these braking maneuvers.

Refer to the description of the Brake Assist System (BAS) (▷ page 60).

Brake pad wear or a leak in the system may be the reason for low brake fluid level in the reservoir.

The brake fluid level in the reservoir may be too low if the red brake warning lamp in the instrument cluster comes on while the engine is running and an acoustic warning sounds (▷ page 376). Observe additional messages in the multifunction display that may appear (▷ page 387).

Have the brake system inspected immediately. Contact an authorized Mercedes-Benz Center.

All checks and service work on the brake system should be carried out by qualified technicians only. Contact an authorized Mercedes-Benz Center.

Only install brake pads and brake fluid recommended by Mercedes-Benz.

### Warning!



If other than recommended brake pads are installed, or other than recommended brake fluid is used, the braking properties of the vehicle can be degraded to an extent that safe braking is substantially impaired. This could result in an accident.

**!** *When driving down long and steep grades, relieve the load on the brakes by shifting into a lower gear to use the engine's braking power. This helps prevent overheating of the brakes and reduces brake pad wear.*

*When using the engine's braking power, a drive wheel may not spin for an extended period of time, e.g. on slippery road surfaces.*

*This may cause serious damage to the drivetrain which is not covered by the Mercedes-Benz Limited Warranty.*

After hard braking, it is advisable to drive on for some time, rather than immediately park, so that the air stream can cool down the brakes faster.

## Driving instructions

### Driving off

Apply the brakes to test them briefly after driving off. Perform this procedure only when the road is clear of other traffic.

Warm up the engine smoothly. Do not place full load on the engine until the operating temperature has been reached.

**!** *When driving off on a slippery surface, do not allow a drive wheel to spin for an extended period with the ESP<sup>®</sup> switched off. Doing so may cause serious damage to the drivetrain which is not covered by the Mercedes-Benz Limited Warranty.*

**!** *Simultaneously depressing the accelerator pedal and applying the brakes reduces engine performance and causes premature brake and drivetrain wear.*

### Parking

#### Warning!



Do not park this vehicle in areas where combustible materials such as grass, hay or leaves can come into contact with the hot exhaust system, as these materials could be ignited and cause a vehicle fire.

To reduce the risk of personal injury, or damage to the vehicle or the vehicle drivetrain, as a result of vehicle movement, always do the following before turning off the engine and leaving the vehicle:

- Keep right foot on brake pedal.
- Manual transmission: Move the gear shift lever to neutral position (no gear selected).
- Firmly depress the parking brake.
- Manual transmission: Move the gear shift lever into first or reverse gear.
- Automatic transmission\*: Move the gear selector lever to position **P**.

- Slowly release brake pedal.
- When parked on an incline, turn front wheels towards the road curb.
- Turn the SmartKey or the SmartKey with KEYLESS-GO\* (Canada only) to starter switch position **0** and remove, or press the KEYLESS-GO\* start/stop button.
- Take the SmartKey or the SmartKey with KEYLESS-GO\* with you and lock the vehicle when leaving.

## Tires

### Warning!



If you feel a sudden significant vibration or ride disturbance, or you suspect that possible damage to your vehicle has occurred, you should turn on the hazard warning flashers, carefully slow down, and drive with caution to an area which is a safe distance from the road.

Inspect the tires and the vehicle underbody for possible damage. If the vehicle or tires appear unsafe, have the vehicle towed to the nearest Mercedes-Benz Center or tire dealer for repairs.

Treadwear indicators (TWI) are required by law. These indicators are located in six places on the tread circumference and become visible at a tread depth of approximately  $1/16$  in (1.6 mm), at which point the tire is considered worn and should be replaced.

The treadwear indicator appears as a solid band across the tread.

### Warning!



Although the applicable federal motor vehicle safety laws consider a tire to be worn when the treadwear indicators (TWI) become visible at approximately  $1/16$  in (1.6 mm), we recommend that you do not allow your tires to wear down to that level. As tread depth approaches  $1/8$  in (3 mm), the adhesion properties on a wet road are sharply reduced.

Depending upon the weather and/or road surface (conditions), the tire traction varies widely.

Specified tire inflation pressures must be maintained. This applies particularly if the tires are subject to extreme operating conditions (e.g. high speeds, heavy loads, high ambient temperatures).

### Warning!



Do not drive with a flat tire. A flat tire affects the ability to steer or brake the vehicle. You may lose control of the vehicle. Continued driving with a flat tire or driving at high speed with a flat tire will cause excessive heat build-up and possibly a fire.

For more information, see “Tires and wheels” (▷ page 331).

## Hydroplaning

Depending on the depth of the water layer on the road, hydroplaning may occur, even at low speeds and with new tires. Reduce vehicle speed, avoid track grooves in the road and apply brakes cautiously in the rain.

## Driving instructions

### Tire traction

The safe speed on a wet, snow covered or icy road is always lower than on a dry road.

You should pay particular attention to the condition of the road whenever the outside temperatures are close to the freezing point.

#### Warning!



If ice has formed on the road, tire traction will be substantially reduced. Under such weather conditions, drive, steer and brake with extreme caution.

Mercedes-Benz recommends winter tires (▷ page 360) with a minimum tread depth of approximately  $\frac{1}{8}$  in (4 mm) on all four wheels for the winter season to ensure normal balanced handling characteristics. On packed snow, they can reduce your stopping distance compared to summer tires.

Stopping distance, however, is still considerably greater than when the road is not covered with snow or ice. Exercise appropriate caution.

**!** *Avoid spinning of a drive wheel. This may cause serious damage to the drivetrain which is not covered by the Mercedes-Benz Limited Warranty.*

### Tire speed rating

Regardless of the tire speed rating, local speed limits should be obeyed. Use prudent driving speeds appropriate to prevailing conditions.

#### Warning!



Even when permitted by law, never operate a vehicle at speeds greater than the maximum speed rating of the tires.

Exceeding the maximum speed for which tires are rated can lead to sudden tire failure, causing loss of vehicle control and possibly resulting in an accident and/or serious personal injury and possible death, for you and for others.

An electronic speed limiter prevents your vehicle from exceeding a speed of 130 mph (210 km/h).

The factory equipped tires on your vehicle may have a tire speed rating above the maximum speed permitted by the electronic speed limiter.

Make sure your tires have the required tire speed rating as specified for your vehicle in the “Technical data” section (▷ page 467), for example when purchasing new tires.

For information on how to identify the tire speed rating on a tire’s sidewall, see “Tire size designation, load and speed rating” (▷ page 348).

If you are uncertain about the correct reading of the information given on a tire’s sidewall, any authorized Mercedes-Benz Center will be glad to assist you.

**i** For information on speed ratings for winter tires, see (▷ page 351) and (▷ page 360).

### Winter driving instructions

The most important rule for slippery or icy roads is to drive sensibly and to avoid abrupt acceleration, braking and steering maneuvers. Do not use the cruise control system under such conditions.

When the vehicle is in danger of skidding, move gear selector lever to position **N**. Try to keep the vehicle under control by corrective steering action.

**i** For information on driving with snow chains, see “Snow chains” (▷ page 361).

#### Warning!



On slippery road surfaces, never downshift in order to obtain braking action. This could result in drive wheel slip and reduced vehicle control. Your vehicle’s ABS will not prevent this type of control loss.

Road salts and chemicals can adversely affect braking efficiency. Increased pedal force may become necessary to produce the normal braking effect.

Depressing the brake pedal periodically when traveling at length on salt-strewn roads can bring road-salt impaired braking efficiency back to normal.

If the vehicle is parked after being driven on salt-treated roads, the braking efficiency should be tested as soon as possible after driving is resumed.

#### Warning!



Make sure not to endanger any other road users when carrying out these braking maneuvers.

### Driving instructions

#### Warning!



If the vehicle becomes stuck in snow, make sure that snow is kept clear of the exhaust pipe and from around the vehicle while the engine is running. Otherwise, deadly carbon monoxide (CO) gases may enter vehicle interior resulting in unconsciousness and death.

To assure sufficient fresh air ventilation, open a window slightly on the side of the vehicle not facing the wind.

#### Warning!



The outside temperature indicator is not designed to serve as an ice-warning device and is therefore unsuitable for that purpose. Indicated temperatures just above the freezing point do not guarantee that the road surface is free of ice.

For more information on winter driving, see “Winter driving” (▷ page 360).

### Standing water

**!** *Do not drive through flooded areas or water of unknown depth. Before driving through water, determine its depth. Never accelerate before driving into water. The bow wave could force water into the engine and auxiliary equipment, thus damaging them.*

*If you must drive through standing water, drive slowly to prevent water from entering the passenger compartment or the engine compartment. Water in these areas could cause damage to electrical components or wiring of the engine or transmission, or could result in water being ingested by the engine through the air intake causing severe internal engine damage. Any such damage is not covered by the Mercedes-Benz Limited Warranty.*

### Passenger compartment

#### Warning!



Always fasten items being carried as securely as possible.

In an accident, during hard braking or sudden maneuvers, loose items will be thrown around inside the vehicle, and cause injury to vehicle occupants unless the items are securely fastened in the vehicle.

The trunk is the preferred place to carry objects.

### Driving abroad

Abroad, there is an extensive Mercedes-Benz service network at your disposal. If you plan to drive into areas which are not listed in the index of your Mercedes-Benz Center directory, you should request pertinent information from an authorized Mercedes-Benz Center.

## Control and operation of radio transmitters

### COMAND\*, radio, and telephone\*

#### Warning!



Please do not forget that your primary responsibility is to drive the vehicle safely. Only operate the COMAND (Cockpit Management and Data System), radio, or telephone<sup>1</sup> if road, weather and traffic conditions permit. Otherwise, you may not be able to observe traffic conditions and could endanger yourself and others.

Bear in mind that at a speed of just 30 mph (approximately 50 km/h), your vehicle is covering a distance of 44 feet (approximately 14 m) every second.

<sup>1</sup> Observe all legal requirements.

## Telephones and two-way radios

#### Warning!



Never operate radio transmitters equipped with a built-in or attached antenna (i.e. without being connected to an external antenna) from inside the vehicle while the engine is running. Doing so could lead to a malfunction of the vehicle's electronic system, possibly resulting in an accident and/or personal injury.

Radio transmitters, such as a portable telephone or a citizens band unit should only be used inside the vehicle if they are connected to an antenna that is installed on the outside of the vehicle.

Refer to the radio transmitter operation instructions regarding use of an external antenna.

## Catalytic converter

Your Mercedes-Benz is equipped with monolithic-type catalytic converters, an important element in conjunction with the oxygen sensors to achieve substantial control of the pollutants in the exhaust emissions. Keep your vehicle in proper operating condition by following our recommended maintenance instructions as outlined in your Maintenance Booklet.

**!** *To prevent damage to the catalytic converters, only use premium unleaded gasoline in this vehicle.*

*Any noticeable irregularities in engine operation should be repaired promptly. Otherwise, excessive unburned fuel may reach the catalytic converter, causing it to overheat and potentially start a fire.*



### Driving instructions

#### Warning!



As with any vehicle, do not idle, park or operate this vehicle in areas where combustible materials such as grass, hay or leaves can come into contact with the hot exhaust system, as these materials could be ignited and cause a vehicle fire.

#### Emission control

Certain systems of the engine and the emission control system serve to keep the toxic components of the exhaust gases within permissible limits required by law.

These systems will function properly only when maintained strictly according to factory specifications. Any adjustments on the engine should, therefore, be carried out only by qualified Mercedes-Benz Center authorized technicians.

Engine adjustments should not be altered in any way. The specified service procedures must be carried out regularly according to Mercedes-Benz servicing requirements. For details please refer to the Maintenance Booklet.

#### Warning!



Inhalation of exhaust gas is hazardous to your health. All exhaust gas contains carbon monoxide (CO), and inhaling it can cause unconsciousness and possible death.

Do not run the engine in confined areas (such as a garage) which are not properly ventilated. If you think that exhaust gas fumes are entering the vehicle while driving, have the cause determined and corrected immediately. If you must drive under these conditions, drive only with at least one window fully open at all times.

## Coolant temperature

During severe operating conditions, e.g. stop-and-go traffic, the coolant temperature may rise to approximately 248°F (120°C).

The engine should not be operated with the coolant temperature over 248°F (120°C). Doing so may cause serious engine damage which is not covered by the Mercedes-Benz Limited Warranty.

### Warning!



- Driving when your engine is badly overheated can cause some fluids, which may have leaked into the engine compartment, to catch fire. You could be seriously burned.
- Steam from an overheated engine can cause serious burns and can occur just by opening the hood. Stay away from the engine if you see or hear steam coming from it.

Stop the vehicle in a safe location away from other traffic. Turn off the engine, get out of the vehicle and do not stand near the vehicle until the engine has cooled down.

## At the gas station

### Refueling

#### Warning!



Gasoline is highly flammable and poisonous. It burns violently and can cause serious personal injury.

Never allow sparks, flame or smoking materials near gasoline!

Turn off the engine before refueling.

Whenever you are around gasoline, avoid inhaling fumes and any skin or clothing contact. Extinguish all smoking materials.

Direct skin contact with fuels and the inhalation of fuel vapors can damage your health.

#### Warning!



C 300/C 300 4MATIC/C 300 4MATIC Sport and 300 Sport (with automatic transmission\*):

Flexible Fuel Vehicles (identified by a label reading **Premium gasoline or E85 only!** on fuel filler flap):

Ethanol fuel (E85) and its vapors are highly flammable, poisonous and burn easily. Ethanol fuel can cause serious injuries if ignited or if you come into contact with it or inhale fumes of it. Avoid inhalation of ethanol fumes and skin contact with ethanol. Extinguish all open flames before refueling. Never smoke or create sparks close to ethanol.

The fuel filler flap is located on the right-hand side of the vehicle towards the rear. Locking and unlocking the vehicle with the SmartKey or the SmartKey with KEYLESS-GO\* (Canada only) automatically locks and unlocks the fuel filler flap.

**i** In case that the central locking system does not release the fuel filler flap, or the opening mechanism is clamping, notify Roadside Assistance or an authorized Mercedes-Benz Center.

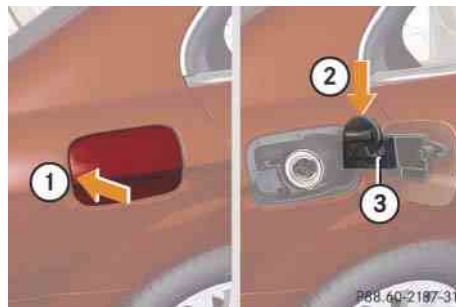

- ① To open fuel filler flap
- ② To insert fuel filler cap
- ③ Holder

**i** Only use premium unleaded gasoline with a minimum Posted Octane Rating of 91 (average of 96 RON/86 MON). Information on gasoline quality can normally be found on the fuel pump. C 300/C 300 4MATIC/C 300 4MATIC Sport and 300 Sport (with automatic transmission\*): Flexible Fuel Vehicles are identified by a label reading **Premium gasoline or E85 only!** on the fuel filler flap.

For more information on gasoline or E85, see “Premium unleaded gasoline” (▷ page 481) or the Factory Approved Service Products pamphlet (USA only) in your vehicle literature portfolio, or contact an authorized Mercedes-Benz Center.

- ▶ Turn off the engine.
- ▶ Vehicles with automatic transmission\*: Move the gear selector lever to position **P** (▷ page 140).
- ▶ Remove the SmartKey from the starter switch.

Vehicles with SmartKey with KEYLESS-GO\*:

- ▶ Turn off the engine by pressing the KEYLESS-GO\* button once.
- ▶ Open the driver’s door (this puts the starter switch in position **0**, same as with the SmartKey removed from the starter switch). The driver’s door then can be closed again.
- ▶ Open the fuel filler flap by pushing at the point indicated by arrow ①.

The fuel filler flap springs open.

- ▶ Turn the fuel cap counterclockwise and hold on to it until possible pressure is released.
- ▶ Take off the fuel filler cap and set it in the direction of arrow ② and place it into holder ④ located on the inside of the fuel filler flap.

To prevent fuel vapors from escaping into open air, fully insert filler nozzle unit.

- ▶ Only fill your tank until the filler nozzle unit cuts out – **do not top off or overfill.**

- ▶ Replace the fuel cap by turning it clockwise until it audibly engages.

**i** Make sure to close the fuel filler flap before locking your vehicle as the flap locking pin prevents closing after you have locked the vehicle.

- ▶ Close the fuel filler flap.

You should hear the latch close shut.

**i** Leaving the engine running and the fuel cap open can cause the yellow engine malfunction indicator lamp  to illuminate.

For more information, see the “Practical hints” section (▷ page 378).

### Warning!



Overfilling of the fuel tank may create pressure in the system which could cause a gas discharge. This could cause the gas to spray back out when removing the fuel pump nozzle, which could cause personal injury.

### At the gas station

#### Check regularly and before a long trip



- ① Coolant level
- ② Brake fluid
- ③ Windshield washer and headlamp cleaning system\*

**i** Opening the hood (▷ page 325).

#### Windshield washer system and headlamp cleaning system\*

For more information on refilling the washer reservoir, see “Windshield washer system and headlamp cleaning system\*” (▷ page 330).

#### Coolant

For more information on coolant, see “Coolant level” (▷ page 329) and see “Fuels, coolants, lubricants, etc.” (▷ page 476).

#### Brake fluid

**!** *If you find that the brake fluid in the brake fluid reservoir has fallen to the minimum mark or below, have the brake system checked for brake pad thickness and leaks immediately. Notify an authorized Mercedes-Benz Center immediately. Do not add brake fluid as this will not solve the problem. For more information, see “Practical hints” (▷ page 376) and (▷ page 400).*

For information on brake fluid, see “Brake fluid” (▷ page 480).

#### Engine oil level

For more information on engine oil, see “Engine oil” (▷ page 327).

#### Vehicle lighting

Check function and cleanliness. For more information on replacing light bulbs, see “Replacing bulbs” (▷ page 430).

For more information, see “Lighting” (▷ page 108).

#### Tire inflation pressure

For information on tire inflation pressure, see “Checking tire inflation pressure” (▷ page 341).

## ▼ Engine compartment

### Hood

#### Warning!



Do not pull the release lever while the vehicle is in motion. Otherwise the hood could be forced open by passing air flow.

This could cause the hood to come loose and injure you and/or others.

### Opening

#### Warning!



If you see flames or smoke coming from the engine compartment, or if the coolant temperature gauge indicates that the engine is overheated, do not open the hood. Move away from vehicle and do not open the hood until the engine has cooled down. If necessary, call the fire department.

#### Warning!



You could be injured when the hood is open – even when the engine is turned off.

Parts of the engine can become very hot. To prevent burns, let the engine cool off completely before touching any components on the vehicle. Comply with all relevant safety precautions.

#### Warning!



To help prevent personal injury, stay clear of moving parts when the hood is open and the engine is running.

The radiator fan may continue to run for approximately 30 seconds or even restart after the engine has been turned off. Stay clear of fan blades.

#### Warning!



The engine is equipped with a transistorized ignition system. Because of the high voltage it is dangerous to touch any components (ignition coils, spark plug sockets, diagnostic socket) of the ignition system

- with the engine running
- while starting the engine
- if ignition is “on” and the engine is cranked manually

### Engine compartment

The hood lock release lever is located to the left of the steering wheel under the dashboard.



#### ① Release lever

- ▶ Pull release lever ① downwards.

The hood is unlocked.

**!** To avoid damage to the windshield wipers or hood, never open the hood if the wiper arms are folded forward away from the windshield.



#### ② Lever for opening the hood

- ▶ Push lever ② under the hood upwards.
- ▶ Pull up on the hood and then release it.

The hood will be automatically held open at shoulder height by gas-filled struts.

### Closing

#### Warning!



When closing the hood, use extreme caution not to catch hands or fingers.

Be careful that you do not close the hood on anyone.

Make sure the hood is securely engaged before driving off. Do not continue driving if the hood can no longer engage after an accident, for example. The hood could otherwise come loose while the vehicle is in motion and endanger you and/or others.

- ▶ Let the hood drop from a height of approximately 1 ft (30 cm).  
The hood will lock audibly.
- ▶ Check to make sure the hood is fully closed.

If you can raise the hood at a point above the headlamps, then it is not properly closed. Open it again and let it drop with somewhat greater force.

## Engine oil

The amount of oil your engine needs will depend on a number of factors, including driving style. Higher oil consumption can occur when

- the vehicle is new
- the vehicle is driven frequently at higher engine speeds

Engine oil consumption checks should only be made after the vehicle break-in period.

**!** Do not use any special lubricant additives, as these may damage the drive assemblies. Using special additives not approved by Mercedes-Benz may cause damage not covered by the Mercedes-Benz Limited Warranty.

More information on this subject is available at any Mercedes-Benz Center.

## Notes about checking engine oil level

When checking the oil level

- the vehicle must be parked on level ground
- with the engine at operating temperature, the vehicle must have been stationary for at least 5 minutes with the engine turned off
- with the engine not at operating temperature yet, the vehicle must have been stationary for at least 30 minutes with the engine turned off

## Checking engine oil level with the oil dipstick

To check the engine oil level with the oil dipstick, do the following:

- ▶ Open the hood (▷ page 325).



- ① Oil dipstick
- ② Upper mark
- ③ Lower mark

- ▶ Pull out oil dipstick ①.
- ▶ Wipe oil dipstick ① clean.
- ▶ Fully insert oil dipstick ① into the dipstick guide tube.





### Engine compartment

- ▷▷ Pull out oil dipstick ① again after approximately 5 seconds to obtain accurate reading.

The oil level is correct when it is between lower mark ③ (min.) and upper mark ② (max.) of the oil dipstick.

**i** The filling quantity between the upper and lower marks on the oil dipstick is approximately 2.1 US qt. (2.0 l).

- ▶ If necessary, add engine oil.

For adding engine oil (▷ page 328).

For more information on engine oil, see the “Technical data” section (▷ page 476) and (▷ page 480).

For more information on messages in the multifunction display concerning engine oil, see the “Practical hints” section (▷ page 387).

### Adding engine oil

**!** Only use approved engine oils and oil filters required for vehicles with Maintenance System. For a listing of approved engine oils and oil filters, refer to the Factory Approved Service Products pamphlet (USA only) in your vehicle literature portfolio, or contact an authorized Mercedes-Benz Center.

Using engine oils and oil filters of specification other than those expressly required for the Maintenance System, or changing of oil and oil filter at change intervals longer than those called for by the Maintenance System will result in engine or emission control system damage not covered by the Mercedes-Benz Limited Warranty.



① Filler cap

- ▶ Unscrew filler cap ① from filler neck.
- ▶ Add engine oil as required. Be careful not to overfill with oil.

Be careful not to spill any oil when adding. Avoid environmental damage caused by oil entering the ground or water.

**!** Excess oil must be siphoned or drained off. It will cause damage to the engine and emission control system not covered by the Mercedes-Benz Limited Warranty.

- ▶ Screw filler cap ① back on filler neck.

For more information on engine oil, see the “Technical data” section (▷ page 476) and (▷ page 480).

### Transmission fluid level

The transmission fluid level does not need to be checked. If you notice transmission fluid loss or gear shifting malfunctions, have an authorized Mercedes-Benz Center check the transmission.

## Coolant level

The engine coolant is a mixture of water and anticorrosion/antifreeze. To check the coolant level, the vehicle must be parked on level ground and the engine must be cool.

### Warning!



In order to avoid potentially serious burns:

- Use extreme caution when opening the hood if there are any signs of steam or coolant leaking from the cooling system, or if the coolant temperature gauge indicates that the coolant is overheated.
- Do not remove pressure cap on coolant reservoir if coolant temperature is above 158°F (70°C). Allow engine to cool down before removing cap. The coolant reservoir contains hot fluid and is under pressure.

- Using a rag, slowly open the cap approximately a half-turn to relieve excess pressure. If opened immediately, scalding hot fluid and steam will be blown out under pressure.
- Do not spill antifreeze on hot engine parts. Antifreeze contains ethylene glycol which may burn if it comes into contact with hot engine parts.

The coolant expansion tank is located on the passenger side of the engine compartment.



- ① Cap
- ② Coolant expansion tank
- ③ Fluid level bridge

- ▶ Using a rag, turn cap ① slowly approximately a half-turn counterclockwise to release any excess pressure.
- ▶ Continue turning the cap ① counterclockwise and remove it.

The coolant level is correct if the level

- for cold coolant: reaches the white marking (plastic bridge) ③ inside the coolant expansion tank ②
- for warm coolant: is approximately 0.6 in (1.5 cm) higher
- ▶ Add coolant as required.
- ▶ Replace and tighten cap ①.

For more information on coolant, see the “Technical data” section (▷ page 484).

## Engine compartment

### Windshield washer system and headlamp cleaning system\*

The washer fluid reservoir is located on the left-hand side of the engine compartment when looking in the direction of travel. It supplies the windshield washer system and headlamp cleaning system with washer fluid.



① Cap

Fluid for the windshield washer system and the headlamp cleaning system is supplied from the windshield washer reservoir. It has a capacity of approximately 6.34 US qt (6.0 l).

During all seasons, add MB Windshield Washer Concentrate “MB SummerFit” to water. Premix the windshield washer fluid in a suitable container.

#### Warning!



Washer solvent/antifreeze is highly flammable. Do not spill washer solvent/antifreeze on hot engine parts, because it may ignite and burn. You could be seriously burned.

- ▶ **To open washer fluid reservoir:** Pull tab of cap ① upward.
- ▶ Refill the reservoir with MB Windshield Washer Concentrate and water (or commercially available premixed windshield washer solvent/antifreeze, depending on ambient temperatures).

**!** *Always use washer solvent/antifreeze where temperatures may fall below freezing point. Failure to do so could result in damage to the washer system/reservoir.*

- ▶ **To close washer fluid reservoir:** Press cap ① onto filler hole until it engages.

**!** *Only use washer fluid which is suitable for plastic lenses. Improper washer fluid can damage the plastic lenses of the headlamps.*

For more information, see “Windshield washer system and headlamp cleaning system\*” (▷ page 486).

## ▼ Tires and wheels

Contact an authorized Mercedes-Benz Center for information on tested and recommended rims and tires for summer and winter operation. They can also offer advice concerning tire service and purchase.

### Warning!



Replace rims or tires with the same designation, manufacturer and type as shown on the original part. Contact an authorized Mercedes-Benz Center for further information. If incorrectly sized rims and tires are mounted:

- The wheel brakes or suspension components can be damaged.
- The operating clearance of the wheels and the tires may no longer be correct.

### Warning!



Worn, old tires can cause accidents. If the tire tread is badly worn, or if the tires have sustained damage, replace them.

When replacing rims, only use genuine Mercedes-Benz wheel bolts specified for the particular rim type. Failure to do so can result in the bolts loosening and possibly an accident.

Retreaded tires are not tested or recommended by Mercedes-Benz, since previous damage cannot always be recognized on re-treads. The operating safety of the vehicle cannot be assured when such tires are used.

### Important guidelines

- Only use sets of tires and rims of the same type and make.
- Tires must be of the correct size for the rim.
- Break in new tires for approximately 60 miles (100 km) at moderate speeds.
- Regularly check the tires and rims for damage. Dented or bent rims can cause tire inflation pressure loss and damage to the tire beads.
- If vehicle is heavily loaded, check tire inflation pressure and correct as required.
- Do not allow your tires to wear down too far. Adhesion properties on wet roads are sharply reduced at tread depths of less than  $\frac{1}{8}$  in (3 mm).
- When replacing individual tires, you should mount new tires on the front wheels first (on vehicles with same-sized wheels all around).

## Tires and wheels

### Tire care and maintenance

#### Warning!



Regularly check the tires for damage. Damaged tires can cause tire inflation pressure loss. As a result, you could lose control of your vehicle.

Worn, old tires can cause accidents. If the tire tread is badly worn, or if the tires have sustained damage, replace them.

Regularly check your tire inflation pressure at least once a month. For more information on checking tire inflation pressure, see “Recommended tire inflation pressure” (▷ page 339).

### Tire inspection

Every time you check the tire inflation pressure, you should also inspect your tires for the following:

- excessive treadwear (▷ page 333)
- cord or fabric showing through the tire’s rubber
- bumps, bulges, cuts, cracks or splits in the tread or side of the tire

Replace the tire if you find any of the above conditions.

Make sure you also inspect the spare tire periodically for condition and inflation. Spare tires will age and degrade over time even if never used, and thus should be inspected and replaced when necessary.

### Life of tire

The service life of a tire is dependent upon varying factors including but not limited to:

- Driving style
- Tire inflation pressure
- Distance driven

#### Warning!



Tires and spare tire should be replaced after 6 years, regardless of the remaining tread.

## Tread depth

Do not allow your tires to wear down too far. Adhesion properties on wet roads are sharply reduced at tread depths of less than  $\frac{1}{8}$  in (3 mm).

Treadwear indicators (TWI) are required by law. These indicators are located in six places on the tread circumference and become visible at a tread depth of approximately  $\frac{1}{16}$  in (1.6 mm), at which point the tire is considered worn and should be replaced.

Recommended minimum tire tread depth:

- Summer tires  $\frac{1}{8}$  in (3 mm)
- Winter tires  $\frac{1}{6}$  in (4 mm)

### Warning!



Although the applicable federal motor safety laws consider a tire to be worn when the treadwear indicators (TWI) become visible at approximately  $\frac{1}{16}$  in (1.6 mm), we recommend that you do not allow your tires

to wear down to that level. As tread depth approaches  $\frac{1}{8}$  in (3 mm), the adhesion properties on a wet road are sharply reduced.

Depending upon the weather and/or road surface (conditions), the tire traction varies widely.

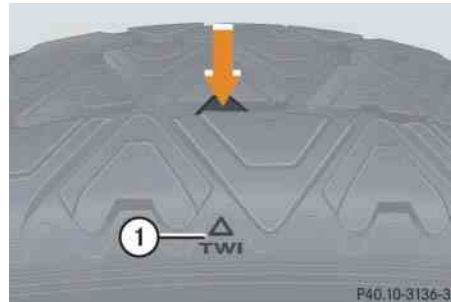

① TWI (TreadWear Indicator)

The treadwear indicator appears as a solid band across the tread.

## Storing tires

**!** *Keep unmounted tires in a cool, dry place with as little exposure to light as possible. Protect tires from contact with oil, grease and gasoline.*

## Cleaning tires

**!** *Never use a round nozzle to power wash tires. The intense jet of water can result in damage to the tire.*

*Always replace a damaged tire.*

### Tires and wheels

#### Direction of rotation

Unidirectional tires offer added advantages, such as better hydroplaning performance. To benefit, however, you must make sure the tires rotate in the direction specified.

An arrow on the sidewall indicates the intended direction of rotation (spinning) of the tire.

**i** *Spare wheels may be mounted against the direction of rotation (spinning) even with a unidirectional tire for temporary use only until the regular drive wheel has been repaired or replaced. Always observe and follow applicable temporary use restrictions and speed limitations indicated on the spare wheel.*

#### Loading the vehicle

Two labels on your vehicle show how much weight it may properly carry.

- 1) The Tire and Loading Information placard can be found on the driver's door B-pillar. This placard tells you important information about the number of people that can be in the vehicle and the total weight that can be carried in the vehicle. It also contains information on the proper size and recommended tire inflation pressures for the original equipment tires on your vehicle.
- 2) The certification label, also found on the driver's door B-pillar tells you about the gross weight capacity of your vehicle, called the Gross Vehicle Weight Rating (GVWR). The GVWR includes the weight of the vehicle, all occupants, fuel and cargo. The certification label also tells you about the front and rear axle weight capacity, called the Gross Axle Weight Rating (GAWR). The GAWR is the total allowable weight that can be

carried by a single axle (front or rear). Never exceed the GVWR or GAWR for either the front axle or rear axle.



#### ① Driver's door B-pillar

Following is a discussion on how to work with the information contained on the Tire and Loading Information placard with regards to loading your vehicle.

## Tire and Loading Information

### Warning!



Do not overload the tires by exceeding the specified load limit or total load limit as indicated on the Tire and Loading Information placard on the driver's door B-pillar. Overloading the tires can overheat them, possibly causing a blowout. Overloading the tires can also result in handling or steering problems, or brake failure.

### Tire and Loading Information placard

**i** Data shown on Tire and Loading Information placard example are for illustration purposes only. Load limit data are specific to each vehicle and may vary from data shown in the illustration below. Refer to Tire and Loading Information placard on vehicle for actual data specific to your vehicle.

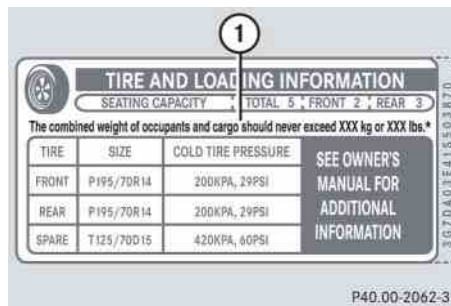

- ① Load limit information on the Tire and Loading Information placard

The Tire and Loading Information placard showing the load limit information is located on the driver's door B-pillar (▷ page 334).

- ▶ Locate the statement “The combined weight of occupants and cargo should never exceed XXX kilograms or XXX lbs.” on the Tire and Loading Information placard.

The combined weight of all occupants, cargo/luggage and trailer tongue load (if applicable) should never exceed the weight referenced in that statement.

### Seating capacity

The seating capacity gives you important information on the number of occupants that can be in the vehicle. Observe front and rear seating capacity. The Tire and Loading Information placard showing the seating capacity is located on the driver's door B-pillar (▷ page 334).

**i** Data shown on Tire and Loading Information placard example are for illustration purposes only. Seating capacity data are specific to each vehicle and may vary from data shown in the illustration below. Refer to Tire and Loading Information placard on vehicle for actual data specific to your vehicle.



## Tires and wheels

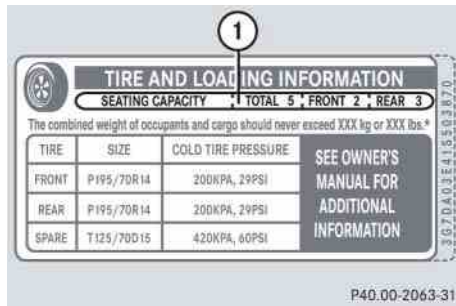

- ① Seating capacity information on the Tire and Loading Information placard

### Steps for determining correct load limit

The following steps have been developed as required of all manufacturers under Title 49, Code of U.S. Federal Regulations, Part 575 pursuant to the “National Traffic and Motor Vehicle Safety Act of 1966”.

#### Step 1

- ▶ Locate the statement “The combined weight of occupants and cargo should never exceed XXX kg or XXX lbs.” on your vehicle’s Tire and Loading Information placard.

#### Step 2

- ▶ Determine the combined weight of the driver and passengers that will be riding in your vehicle.

#### Step 3

- ▶ Subtract the combined weight of the driver and passengers from XXX kilograms or XXX lbs.

#### Step 4

- ▶ The resulting figure equals the available amount of cargo and luggage load capacity. For example, if the “XXX” amount equals 1400 lbs and there will be five 150 lbs passengers in your vehicle, the amount of available cargo and luggage load capacity is 650 lbs ( $1400 - 750 (5 \times 150) = 650$  lbs)

#### Step 5

- ▶ Determine the combined weight of luggage and cargo being loaded on the vehicle. That weight may not safely exceed the available cargo and luggage load capacity calculated in step 4.

#### Step 6 (if applicable)

- ▶ If your vehicle will be towing a trailer, load from your trailer will be transferred to your vehicle. Consult this manual to determine how this reduces the available cargo and luggage load capacity of your vehicle (▷ page 338).

The following table shows examples on how to calculate total and cargo load capacities with varying seating configurations and number and size of occupants. The following examples use a load limit of 1500 lbs. **This is for illustration purposes only.** Make sure you are using the actual load limit for your vehicle stated on the vehicle’s Tire and Loading Information placard (▷ page 335).

Example	Combined weight limit of occupants and cargo from Tire and Loading Information placard	Number of occupants (driver and passengers)	Seating configuration	Occupants weight	Combined weight of all occupants	Available cargo/luggage and trailer tongue weight (total load limit from Tire and Loading Information placard minus combined weight of all occupants)
1	1500 lbs	5	front: 2 rear: 3	Occupant 1: 150 lbs Occupant 2: 180 lbs Occupant 3: 160 lbs Occupant 4: 140 lbs Occupant 5: 120 lbs	750 lbs	1500 lbs – 750 lbs = 750 lbs
2	1500 lbs	3	front: 1 rear: 2	Occupant 1: 200 lbs Occupant 2: 190 lbs Occupant 3: 150 lbs	540 lbs	1500 lbs – 540 lbs = 960 lbs
3	1500 lbs	1	front: 1	Occupant 1: 150 lbs	150 lbs	1500 lbs – 150 lbs = 1350 lbs

The higher the weight of all occupants, the less cargo and luggage load capacity is available.

For more information, see “Trailer tongue load” (> page 338).

### Tires and wheels

#### ***Certification label***

Even after careful determination of the combined weight of all occupants, cargo and the trailer tongue load (if applicable) (▷ page 338) as to not exceed the permissible load limit, you must make sure that your vehicle never exceeds the Gross Vehicle Weight Rating (GVWR) and the Gross Axle Weight Rating (GAWR) for either the front or rear axle. You can obtain the GVWR and GAWR from the certification label. The certification label can be found on the driver's door B-pillar, see "Technical data" (▷ page 462).

**Gross Vehicle Weight Rating (GVWR):** The total weight of the vehicle, all occupants, all cargo, and the trailer tongue load (▷ page 338) must never exceed the GVWR.

**Gross Axle Weight Rating (GAWR):** The total allowable weight that can be carried by a single axle (front or rear).

To assure that your vehicle does not exceed the maximum permissible weight limits (GVWR and GAWR for front and rear axle), have the loaded vehicle (including driver, passengers and all cargo and, if applicable, trailer fully loaded) weighed on a suitable commercial scale.

#### ***Trailer tongue load***

The tongue load of any trailer is an important weight to measure because it affects the load you can carry in your vehicle. If a trailer is towed, the tongue load must be added to the weight of all occupants riding and any cargo you are carrying in the vehicle. The tongue load typically is 10 percent of the trailer weight and everything loaded in it.

Your Mercedes-Benz has been designed primarily to carry passengers and their cargo. Mercedes-Benz does not recommend trailer towing with your vehicle.

## Recommended tire inflation pressure

### Warning!



Follow recommended tire inflation pressures.

Do not underinflate tires. Underinflated tires wear excessively and/or unevenly, adversely affect handling and fuel economy, and are more likely to fail from being overheated.

Do not overinflate tires. Overinflated tires can adversely affect handling and ride comfort, wear unevenly, increase stopping distance, and result in sudden deflation (blowout) because they are more likely to become punctured or damaged by road debris, potholes etc.

Do not overload the tires by exceeding the specified load limit or total load limit as indicated on the Tire and Loading Information placard on the driver's door B-pillar. Overloading the tires can overheat them, possibly causing a blowout. Overloading the tires can also result in handling or steering problems, or brake failure.

Your vehicle is equipped with the Tire and Loading Information placard located on the driver's door B-pillar (▷ page 334).

The tire inflation pressure should be checked regularly and should only be adjusted on cold tires. The tires can be considered cold if the vehicle has been parked for at least 3 hours or driven less than 1 mile (1.6 km).

Follow recommended cold tire inflation pressures listed on Tire and Loading Information placard on the driver's door B-pillar.

Keeping the tires properly inflated provides the best handling, tread life and riding comfort.

In addition to the tire Tire and Loading Information placard on the driver's door B-pillar, also consult the tire inflation pressure label (if available) on the fuel filler flap (▷ page 322) for any additional information pertaining to special driving situations. For more information, see "Important notes on tire inflation pressure" (▷ page 340).

 *Data shown on Tire and Loading Information placard example are for illustration purposes only. Tire data are specific to each vehicle and may vary from data shown in the illustration below. Refer to Tire and Loading Information placard on vehicle for actual data specific to your vehicle.*

## Tires and wheels

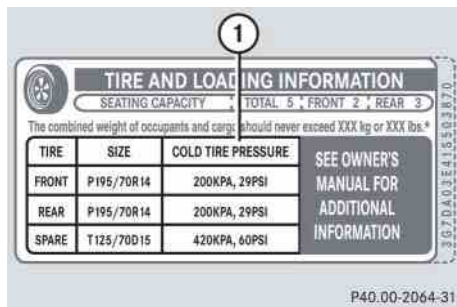

- ① Tire and Loading Information placard with recommended cold tire inflation pressures

The Tire and Loading Information placard lists the recommended cold tire inflation pressures for maximum loaded vehicle weight. The tire inflation pressures listed apply to the tires installed as original equipment.

### Important notes on tire inflation pressure

#### Warning!



If the tire inflation pressure drops repeatedly:

- Check the tires for punctures from foreign objects.
- Check to see whether air is leaking from the valves or from around the rim.

Tire temperature and tire inflation pressure are also increased while driving, depending on the driving speed and the tire load.

If you will be driving your vehicle at high speeds of 100 mph (160 km/h) or higher, where it is legal and conditions allow, consult the tire inflation pressure label (if available) on the inside of the fuel filler flap on how to adjust the cold tire inflation pressure. If you do not adjust the tire inflation pressure, excessive heat can build up and result in sudden tire failure.

**i** Driving comfort may be reduced when the tire inflation pressure is adjusted to the value for speeds above 100 mph (160 km/h) as specified on the tire inflation pressure label (if available) located on the inside of the fuel filler flap.

Make sure to readjust the tire inflation pressure for normal driving speeds. You should wait until the tires are cold before adjusting the tire inflation pressure.

Some vehicles may have supplemental tire inflation pressure information for vehicle loads less than the maximum loaded vehicle condition (▷ page 348). If such information is provided, it can be found on the tire inflation pressure label located on the inside of the fuel filler flap (▷ page 322).

Tire inflation pressure changes by approximately 1.5 psi (0.1 bar) per 18°F (10°C) of air temperature change. Keep this in mind when checking tire inflation pressure where the temperature is different from the outside temperature.

## Checking tire inflation pressure

Regularly check the tire inflation pressure at least once a month.

Check and adjust the tire inflation pressure when the tires are cold. The tires can be considered cold if the vehicle has been parked for at least 3 hours or driven less than 1 mile (1.6 km).

If you check the tire inflation pressure when the tires are warm (the vehicle has been driven for several miles or sitting less than 3 hours), the reading will be approximately 4 psi (0.3 bar) higher than the cold reading. This is normal. Do not let air out to match the specified cold tire inflation pressure. Otherwise, the tire will be underinflated.

### Warning!



Follow recommended tire inflation pressures.

Do not underinflate tires. Underinflated tires

wear excessively and/or unevenly, adversely affect handling and fuel economy, and are more likely to fail from being overheated.

Do not overinflate tires. Overinflated tires can adversely affect handling and ride comfort, wear unevenly, increase stopping distance, and result in sudden deflation (blowout) because they are more likely to become punctured or damaged by road debris, potholes etc.

Do not overload the tires by exceeding the specified load limit or total load limit as indicated on the Tire and Loading Information placard on the driver's door B-pillar. Overloading the tires can overheat them, possibly causing a blowout. Overloading the tires can also result in handling or steering problems, or brake failure.

## Checking tire inflation pressure manually

Follow the steps below to achieve correct tire inflation pressure:

- ▶ Remove the cap from the valve on one tire.
  - ▶ Firmly press a tire gauge onto the valve.
  - ▶ Read tire inflation pressure on tire gauge and check against the recommended tire inflation pressure on the Tire and Loading Information placard on the driver's door B-pillar (> page 334) or, if available, the supplemental tire inflation pressure information on the inside of the fuel filler flap (> page 322). If necessary, add air to achieve the recommended tire inflation pressure.
- i** *If you have overfilled the tire, release tire inflation pressure by pushing the metal stem of the valve with e.g. a tip of a pen. Then recheck the tire inflation pressure with the tire gauge.*
- ▶ Install the valve cap.
  - ▶ Repeat this procedure for each tire.

## Tires and wheels

### Run Flat Indicator (Canada only)

While the vehicle is being driven, the Run Flat Indicator monitors the set tire inflation pressures by evaluating each wheel's rotational speed. This allows the system to detect a significant loss of pressure in a tire. If a wheel's rotational speed changes due to falling tire inflation pressure, you will see a corresponding warning message in the multifunction display.

The Run Flat Indicator may function in a restricted manner or with a delay if:

- snow chains are mounted to the vehicle
- winter road conditions prevail
- you are driving on a loose surface (e.g. sand or gravel)
- you are driving in a very sporty manner (involving rapid acceleration or high speeds in curves)

### Warning!



When the multifunction display shows the message **Check Tire Pressure Soon**, one or more of your tires is significantly underinflated. You should stop and check your tires as soon as possible, and inflate them to the proper tire inflation pressure as indicated on the vehicle's Tire and Loading Information placard or, if available, on the tire inflation pressure label. Driving on a significantly underinflated tire causes the tire to overheat and can lead to tire failure. Underinflation also reduces fuel efficiency and tire tread life, and may affect the vehicle's handling and stopping ability. Each tire, including the spare, should be checked monthly when cold and set to the recommended tire inflation pressure as specified on the Tire and Loading Information placard on the driver's door B-pillar (▷ page 334) or, if available, on the tire inflation pressure label located on the inside of the fuel filler label (▷ page 322).

### Warning!



The Run Flat Indicator does not indicate a warning for wrongly selected tire inflation pressures. Always adjust tire inflation pressure according to the Tire and Loading Information placard on the driver's door B-pillar (▷ page 334) or, if available, on the tire inflation pressure label located on the inside of the fuel filler flap (▷ page 322).

The Run Flat Indicator does not replace regular checks of the tire inflation pressures since a gradual pressure loss in more than one tire cannot be detected by the Run Flat Indicator.

The Run Flat Indicator is not able to issue a warning due to a sudden dramatic loss of tire inflation pressure (e.g. tire blowout caused by a foreign object). In this case bring the vehicle to a halt by carefully applying the brakes and avoiding abrupt steering maneuvers.

**Restart the Run Flat Indicator**





The tire inflation pressure monitor must be restarted in the following situations:

- If you have changed the tire inflation pressure
  - If you have replaced the wheels or tires
  - If you have installed new wheels or tires
- ▶ Using the Tire and Loading Information placard on the driver's door B-pillar (▷ page 334) or, if available, the supplemental tire inflation pressure information on the inside of the fuel filler flap (▷ page 322), make sure the tire inflation pressure of all four tires is correct.

**Warning!**

The Run Flat Indicator can only warn you in a reliable manner if you have set the correct tire inflation pressures for each tire.



If an incorrect tire inflation pressure was set, the system will monitor the pressure according to the incorrect value.

- ▶ Switch on the ignition (▷ page 82).
- ▶ Press button  or  on the multifunction steering wheel to select the menu *Service* (▷ page 164).
- ▶ Press button  or  to select *Run Flat Indicator*.
- ▶ Press the button  to confirm. The following message appears in the multifunction display:  
Run Flat Indicator  
Active  
Menu: OK-Button

- ▶ Press button .

The following message will appear in the multifunction display:

Restart  
Run Flat Indicator?  
Yes or No

- ▶ Press button  or  to select Yes.
- ▶ Press button  to confirm.

The following message will appear in the multifunction display:



Run Flat Indicator  
Restarted

After a certain “learning phase”, the Run Flat Indicator checks the set pressure values for all four tires. >>



### Tires and wheels

▷▷ If you wish to cancel activation:

- ▶ Press button  or  to select No.
  - ▶ Press button  to confirm. The previous settings will not be changed
- or
- ▶ Wait until the message Run Flat Indicator? Restart disappears.

#### Checking tire pressure electronically with the Tire Pressure Monitoring System (TPMS), (USA only)

 *The Tire Pressure Monitoring System (TPMS) is equipped with a combination low tire pressure/TPMS malfunction telltale in the instrument cluster (▷ page 26). Depending on how the telltale illuminates, it indicates a low tire pressure condition or a malfunction in the TPMS system itself:*

- *If the telltale illuminates continuously, one or more of your tires is significantly underinflated. There is no malfunction in the TPMS.*

- *If the telltale flashes for 60 seconds and then stays illuminated, the TPMS system itself is not operating properly.*

 *This device complies with Part 15 of the FCC Rules. Operation is subject to the following two conditions:*

- (1) This device may not cause harmful interference, and*
- (2) this device must accept any interference received, including interference that may cause undesired operation.*

*Any unauthorized modification to this device could void the user's authority to operate the equipment.*

The TPMS only functions on wheels that are equipped with the proper electronic sensors. It monitors the tire inflation pressure, as selected by the driver, in all four tires. A warning is issued to alert you to a decrease in pressure in one or more of the tires.

#### Warning!



The TPMS does not indicate a warning for wrongly selected inflation pressures. Always adjust tire inflation pressure according to the Tire and Loading Information placard on the driver's door B-pillar or, if available, the supplemental tire pressure information on the inside of the fuel filler flap.

The TPMS is not able to issue a warning due to a sudden dramatic loss of pressure (e.g. tire blowout caused by a foreign object). In this case bring the vehicle to a halt by carefully applying the brakes and avoiding abrupt steering maneuvers.

**Warning!**

Each tire, including the Minispare, should be checked monthly when cold and inflated to the inflation pressure recommended by the vehicle manufacturer on the Tire and Loading Information placard or, if available, on the tire inflation pressure label. If your vehicle has tires of a different size than the size indicated on the Tire and Loading Information placard or, if available, the tire inflation pressure label, you should determine the proper tire inflation pressure for those tires.

As an added safety feature, your vehicle has been equipped with a tire pressure monitoring system (TPMS) that illuminates a low tire pressure telltale when one or more of your tires is significantly underinflated. Accordingly, when the low tire pressure telltale illuminates, you should stop and check your tires as soon as possible, and inflate them to the proper pressure. Driving on a significantly underinflated tire causes the tire to overheat and can lead to tire failure.

Underinflation also reduces fuel efficiency and tire tread life, and may affect the vehicle's handling and stopping ability. Please note that the TPMS is not a substitute for proper tire maintenance, and it is the driver's responsibility to maintain correct tire pressure, even if underinflation has not reached the level to trigger illumination of the TPMS low tire pressure telltale.

Your vehicle has also been equipped with a TPMS malfunction indicator to indicate when the system is not operating properly. The TPMS malfunction indicator is combined with the low tire pressure telltale. When the system detects a malfunction, the telltale will flash for approximately 1 minute and then remain continuously illuminated. This sequence will continue upon subsequent vehicle start-ups as long as the malfunction exists. When the malfunction indicator is illuminated, the system may not be able to detect or signal low tire pressure as intended.

TPMS malfunctions may occur for a variety of reasons, including the installation of replacement or alternate tires or wheels on the vehicle that prevent the TPMS from functioning properly. Always check the TPMS malfunction telltale after replacing one or more tires or wheels on your vehicle to ensure that the replacement or alternate tires and wheels allow the TPMS to continue to function properly.

**i** *If a condition causing the TPMS to malfunction develops, it may take up to 10 minutes for the system to signal a malfunction using the TPMS telltale flashing and illumination sequence.*

*The telltale extinguishes after a few minutes driving if the malfunction has been corrected.*

**i** *Operating radio transmission equipment (e.g. wireless headsets, two-way radios) in or near the vehicle could cause the TPMS to malfunction.*

## Tires and wheels

### Tire inflation pressure warnings

If the system detects a significant loss of tire inflation pressure in one or more than one tire, a message appears in the multifunction display.



#### Example illustration

In addition, a warning signal sounds.

### Restarting the TPMS

#### Warning!



It is the driver's responsibility to calibrate the TPMS on the recommended cold inflation pressure. Underinflated tires affect the ability to steer or brake the vehicle. You might lose control over the vehicle.

The TPMS must be restarted when you have adjusted the tire inflation pressure to a new level (e.g. because of different load or driving conditions). The TPMS is then recalibrated to the current tire inflation pressures.

- ▶ Using the Tire and Loading Information placard on the driver's door B-pillar (▷ page 334) or, if available, the supplemental tire inflation pressure information on the inside of the fuel filler flap (▷ page 322), make sure the tire inflation pressure of all four tires is correct.

**i** Restart the TPMS after adjusting the tire inflation pressure to the inflation pressure recommended for the vehicle operating condition. Tire pressure should only be adjusted on cold tires. Observe the recommended tire inflation pressure on the Tire and Loading Information placard on the driver's door B-pillar (▷ page 334). Some vehicles may have supplemental tire inflation pressure information for driving at high speeds (▷ page 340) or for vehicle loads less than the maximum loaded vehicle condition (▷ page 334). If such information is provided, it can be found on the inside of the fuel filler flap.

- ▶ Switch on the ignition (▷ page 82).
- ▶ Press button or on the multifunction steering wheel to select the menu Service (▷ page 164).
- ▶ Press button or to select Tire Pressure.
- ▶ Press the button to confirm. The following message appears in the multifunction display:  
Tire Pressure Monitor Active



- ▶ Press button .

The following message will appear in the multifunction display:

Restart tire pressure monitor?  
Yes or No

▶ Press button  or  to select Yes.

▶ Press button  to confirm.

The following message will appear in the multifunction display:

Tire Press. Monitor  
Reactivated

After driving a few minutes the current tire inflation pressure values are accepted as reference pressures and then monitored.

If you wish to cancel activation:

▶ Press button  or  to select No.

▶ Press button  to confirm.  
The previous settings will not be changed

### Potential problems associated with underinflated and overinflated tires

#### *Underinflated tires*

Underinflated tires can:

- cause excessive and uneven tire wear
- adversely affect fuel economy
- lead to tire failure from being overheated
- adversely affect handling characteristics

#### **Warning!**



Follow recommended tire inflation pressures.

Do not underinflate tires. Underinflated tires wear excessively and/or unevenly, adversely affect handling and fuel economy, and are more likely to fail from being overheated.

#### *Overinflated tires*

Overinflated tires can:

- adversely affect handling characteristics
- cause uneven tire wear
- be more prone to damage from road hazards
- adversely affect ride comfort
- increase stopping distance

#### **Warning!**



Follow recommended tire inflation pressures.

Do not overinflate tires. Overinflated tires can adversely affect handling and ride comfort, wear unevenly, increase stopping distance, and result in sudden deflation (blowout) because they are more likely to become punctured or damaged by road debris, potholes etc.

## Tires and wheels

### Tire labeling

Besides tire name (sales designation) and manufacturer name, a number of markings can be found on a tire.

Following are some explanations for the markings on your vehicle's tires:

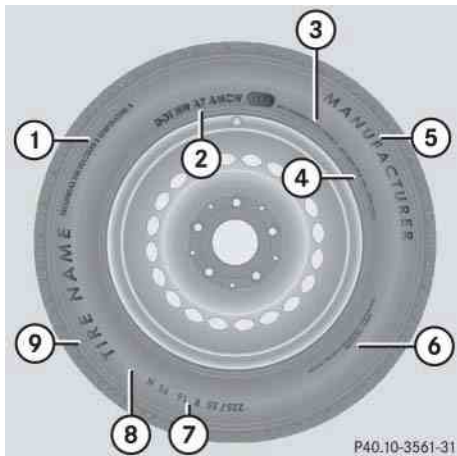

- ① Uniform Quality Grading Standards (▷ page 354)
- ② DOT, Tire Identification Number (TIN) (▷ page 352)
- ③ Maximum tire load (▷ page 353)
- ④ Maximum tire inflation pressure (▷ page 354)
- ⑤ Manufacturer
- ⑥ Tire ply material (▷ page 356)
- ⑦ Tire size designation, load and speed rating (▷ page 348)
- ⑧ Load identification (▷ page 352)
- ⑨ Tire name

**i** For illustration purposes only. Actual data on tires are specific to each vehicle and may vary from data shown in above illustration.

For more information, see “Rims and tires” (▷ page 467).

### Tire size designation, load and speed rating

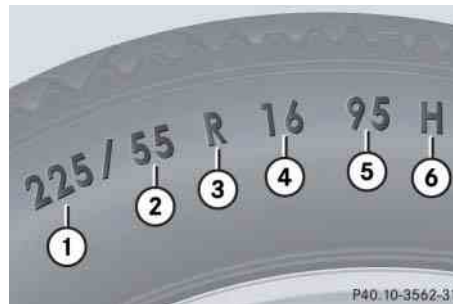

- ① Tire width
- ② Aspect ratio in %
- ③ Radial tire code
- ④ Rim diameter
- ⑤ Tire load rating
- ⑥ Tire speed rating

**i** For illustration purposes only. Actual data on tires are specific to each vehicle and may vary from data shown in above illustration.

**General:**

Depending on the design standards used, the tire size molded into the sidewall may have no letter or a letter preceding the tire size designation.

No letter preceding the size designation (as illustrated above): Passenger car tire based on European design standards.

Letter “P” preceding the size designation: Passenger car tire based on U.S. design standards.

Letter “LT” preceding the size designation: Light Truck tire based on U.S. design standards.

Letter “T” preceding the size designation: Temporary spare tires which are high pressure compact spares designed for temporary emergency use only.

***Tire width***

The tire width ① (▷ page 348) indicates the nominal tire width in mm.

***Aspect ratio***

The aspect ratio ② (▷ page 348) is the dimensional relationship between tire section height and section width and is expressed in percentage. The aspect ratio is arrived at by dividing section height by section width.

***Tire code***

The tire code ③ (▷ page 348) indicates the tire construction type. The “R” stands for radial tire type. Letter “D” means diagonal or bias ply construction; letter “B” means belted-bias ply construction.

At the tire manufacturer’s option, any tire with a speed capability above 149 mph (240 km/h) can include a “ZR” in the size designation (for example: 245/40 ZR 18). For additional information, see “Tire speed rating” (▷ page 350).

***Rim diameter***

The rim diameter ④ (▷ page 348) is the diameter of the bead seat, not the diameter of the rim edge. Rim diameter is indicated in inches (in).

***Tire load rating***

The tire load rating ⑤ (▷ page 348) is a numerical code associated with the maximum load a tire can support.

For example, a load rating of 91 corresponds to a maximum load of 1356 lbs (615 kg) the tire is designed to support. See also “Maximum tire load” (▷ page 353) where the maximum load associated with the load index is indicated in kilograms and lbs.

## Tires and wheels

### Warning!



The tire load rating must always be at least half of the GAWR (▷ page 357) of your vehicle. Otherwise, tire failure may be the result which may cause an accident and/or serious personal injury to you or others.

Always replace rims and tires with the same designation, manufacturer and type as shown on the original part.

For additional information on tire load rating, see “Load identification” (▷ page 352).

**i** Tire load rating ⑤ (▷ page 348) and tire speed rating ⑥ (▷ page 348) are also referred to as “service description”.

### Tire speed rating

The tire speed rating ⑥ (▷ page 348) indicates the approved maximum speed for the tire.

**i** Tire load rating ⑤ (▷ page 348) and tire speed rating ⑥ (▷ page 348) are also referred to as “service description”.

### Summer tires

Index	Speed rating
Q	up to 100 mph (160 km/h)
R	up to 106 mph (170 km/h)
S	up to 112 mph (180 km/h)
T	up to 118 mph (190 km/h)
H	up to 130 mph (210 km/h)
V	up to 149 mph (240 km/h)
W	up to 168 mph (270 km/h)
Y	up to 186 mph (300 km/h)
(Y)	above 186 mph (300 km/h)
ZR	above 149 mph (240 km/h)

### Warning!



Do not overload the tires by exceeding the specified load limit or total load limit as indicated on the Tire and Loading Information placard located on the driver’s door B-pillar (▷ page 334). Overloading the tires can overheat them, possibly causing a blowout. Overloading the tires can also result in handling or steering problems, or brake failure.

### Warning!



Even when permitted by law, never operate a vehicle at speeds greater than the maximum speed rating of the tires.

Exceeding the maximum speed for which tires are rated can lead to sudden tire failure, causing loss of vehicle control and possibly resulting in an accident and/or personal injury and possible death, for you and for others.

- At the tire manufacturer’s option, any tire with a speed capability above 149 mph (240 km/h) can include a “ZR” in the size designation (for example: 245/40 ZR18). To determine the maximum speed capability of the tire,

the service description for the tire must be referred to. The service description is comprised of the tire load rating ⑤ (▷ page 348) and the tire speed rating ⑥ (▷ page 348).

If your tire includes “ZR” in the size designation and no service description ⑤ and ⑥ (▷ page 348) is given, the tire manufacturer must be consulted for the maximum speed capability.

If a service description ⑤ and ⑥ (▷ page 348) is given, the speed capability is limited by the speed symbol in the service description.

Example: 245/40 ZR18 97Y.



In this example, “97Y” is the service description. The letter “Y” designates the speed rating and the speed capability of the tire is limited to 186 mph (300 km/h).

- Any tire with a speed capability above 186 mph (300 km/h) must include a “ZR” in the size designation AND the service description must be placed in parenthesis.  
Example: 275/40 ZR 18 (99Y).  
The “(Y)” speed rating in parenthesis designates the maximum speed capability of the tire as being above 186 mph (300 km/h). Consult the tire manufacturer for the actual maximum permissible speed of the tire.

All-season and winter tires

Index	Speed rating
Q M+S <sup>1</sup>	up to 100 mph (160 km/h)
T M+S <sup>1</sup>	up to 118 mph (190 km/h)
H M+S <sup>1</sup>	up to 130 mph (210 km/h)
V M+S <sup>1</sup>	up to 149 mph (240 km/h)

<sup>1</sup> or M+S  for winter tires

 *Not all M+S rated tires provide special winter performance. Make sure the tires you use show M+S and the mountain/snowflake  marking on the tire sidewall. These tires meet specific snow traction performance requirements of the Rubber Manufacturers Association (RMA) and the Rubber Association of Canada (RAC) and have been designed specifically for use in snow conditions.*



## Tires and wheels

### Load identification



#### ① Load identification

**i** For illustration purposes only. Actual data on tires are specific to each vehicle and may vary from data shown in above illustration.

In addition to tire load rating, special load identification ① may be molded into the tire sidewall following the letter designating the tire speed rating ⑥ (▷ page 348).

No specification given: absence of any text (like in above example) indicates a standard load (SL) tire.

XL (Extra Load): designates an extra load (or reinforced) tire.

Light Load: designates a light load tire.

C, D, E: designates load range associated with the maximum load a tire can carry at a specified pressure.

### DOT, Tire Identification Number (TIN)

U.S. tire regulations require each new tire manufacturer or tire retreader to mold a TIN into or onto a sidewall of each tire produced.

The TIN is a unique identifier which facilitates efforts by tire manufacturers to notify purchasers in recall situations or other safety matters concerning tires and gives purchasers the means to easily identify such tires.

The TIN is comprised of “Manufacturer’s identification mark”, “Tire size”, “Tire type code” and “Date of manufacture”.

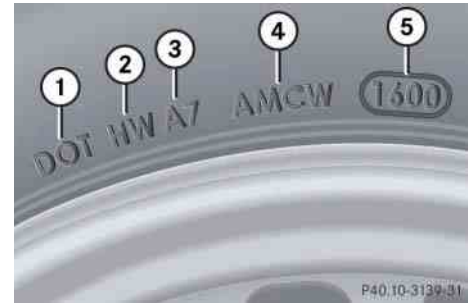

- ① DOT
- ② Manufacturer’s identification mark
- ③ Tire size
- ④ Tire type code (at the option of the tire manufacturer)
- ⑤ Date of manufacture

**i** For illustration purposes only. Actual data on tires are specific to each vehicle and may vary from data shown in above illustration.

### DOT (Department of Transportation)

A tire branding symbol ① (▷ page 352) which denotes the tire meets requirements of the U.S. Department of Transportation.

### Manufacturer's identification mark

The manufacturer's identification mark ② (▷ page 352) denotes the tire manufacturer.

New tires have a mark with two symbols.

Retreaded tires have a mark with four symbols. For more information on retreaded tires (▷ page 331).

### Tire size

The code ③ (▷ page 352) indicates the tire size.

### Tire type code

The code ④ (▷ page 352) may, at the option of the manufacturer, be used as a descriptive code for identifying significant characteristics of the tire.

### Date of manufacture

The date of manufacture ⑤ (▷ page 352) identifies the week and year of manufacture.

The first two figures identify the week, starting with "01" to represent the first full week of the calendar year. The second two figures represent the year.

For example, "3202" represents the 32nd week of 2002.

### Maximum tire load



#### ① Maximum tire load rating

**i** For illustration purposes only. Actual data on tires are specific to each vehicle and may vary from data shown in above illustration.

The maximum tire load is the maximum weight the tires are designed to support.

### Warning!



Do not overload the tires by exceeding the specified load limit or total load limit as indicated on the Tire and Loading Information placard located on the driver's door B-pillar (▷ page 334). Overloading the tires can overheat them, possibly causing a blowout. Overloading the tires can also result in handling or steering problems, or brake failure.

For more information on tire load rating (▷ page 349).

For information on calculating total and cargo load capacities (▷ page 336).

## Tires and wheels

### Maximum tire inflation pressure

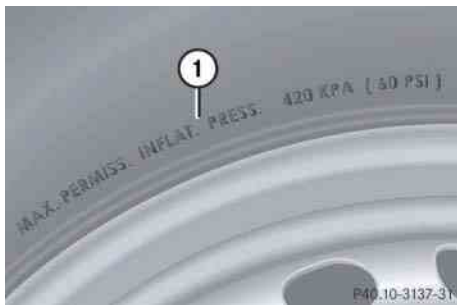

- ① Maximum permissible tire inflation pressure

**i** For illustration purposes only. Actual data on tires are specific to each vehicle and may vary from data shown in above illustration.

This is the maximum permissible tire inflation pressure for the tire.

Always follow the recommended tire inflation pressure (▷ page 339) for proper tire inflation.

### Warning!



Never exceed the max. tire inflation pressure. Follow recommended tire inflation pressures.

Do not underinflate tires. Underinflated tires wear excessively and/or unevenly, adversely affect handling and fuel economy, and are more likely to fail from being overheated.

Do not overinflate tires. Overinflated tires can adversely affect handling and ride comfort, wear unevenly, increase stopping distance, and result in sudden deflation (blowout) because they are more likely to become punctured or damaged by road debris, potholes etc.

### Uniform Tire Quality Grading Standards (U.S. vehicles)

Tire manufacturers are required to grade tires based on three performance factors: treadwear, traction and temperature resistance.

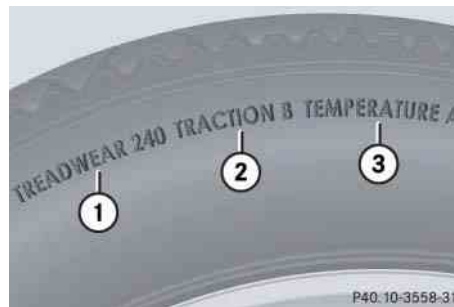

- ① Treadwear
- ② Traction
- ③ Temperature resistance

**i** For illustration purposes only. Actual data on tires are specific to each vehicle and may vary from data shown in above illustration.

Quality grades can be found, where applicable, on the tire sidewall between tread shoulder and maximum section width. For example:

Treadwear	Traction	Temperature
200	AA	A

All passenger car tires must conform to federal safety requirements in addition to these grades.

### Treadwear

The treadwear grade is a comparative rating based on the wear rate of the tire when tested under controlled conditions on a specified government test course. For example, a tire graded 150 would wear one and one-half ( $1 \frac{1}{2}$ ) times as well on the government course as a tire graded 100. The relative performance of tires depends upon the actual conditions of their use, however, and may depart significantly from the norm due to variations in driving habits, service practices and differences in road characteristics and climate.

### Traction

The traction grades, from highest to lowest, are AA, A, B, and C. Those grades represent the tire's ability to stop on wet pavement as measured under controlled conditions on specified government test

surfaces of asphalt and concrete. A tire marked C may have poor traction performance.

#### Warning!



The traction grade assigned to this tire is based on straight-ahead braking traction tests, and does not include acceleration, cornering, hydroplaning, or peak traction characteristics.

### Temperature

The temperature grades are A (the highest), B, and C, representing the tire's resistance to the generation of heat and its ability to dissipate heat when tested under controlled conditions on a specified indoor laboratory test wheel. Sustained high temperature can cause the material of the tire to degenerate and reduce tire life, and excessive temperature can lead to sudden tire failure. The grade C corresponds to the minimum level of performance which all passenger car tires must meet under the

Federal Motor Vehicle Safety Standard No. 109. Grades B and A represent higher levels of performance on the laboratory test wheel than the minimum required by law.

#### Warning!



The temperature grade for this tire is established for a tire that is properly inflated and not overloaded. Excessive speed, underinflation, or excessive loading, either separately or in combination, can cause excessive heat build-up and possible tire failure.

### Tires and wheels

#### Tire ply material

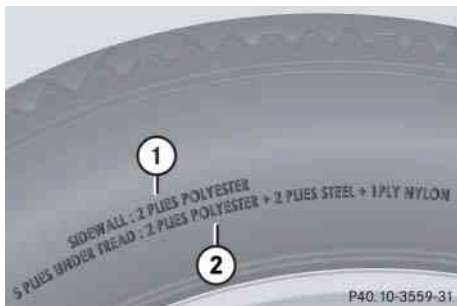

- ① Plies in sidewall
- ② Plies under tread

**i** For illustration purposes only. Actual data on tires are specific to each vehicle and may vary from data shown in above illustration.

This marking tells you about the type of cord and number of plies in the sidewall and under the tread.

#### Tire and loading terminology

##### Accessory weight

The combined weight (in excess of those standard items which may be replaced) of automatic transmission, power steering, power brakes, power windows, power seats, radio, and heater, to the extent that these items are available as factory-installed equipment (whether installed or not).

##### Air pressure

The amount of air inside the tire pressing outward on each square inch of the tire. Air pressure is expressed in pounds per square inch (psi), or kilopascal (kPa) or bars.

##### Aspect ratio

Dimensional relationship between tire section height and section width expressed in percentage.

##### Bar

Another metric unit for air pressure. There are 14.5038 pounds per square inch (psi) to 1 bar; there are 100 kilopascals (kPa) to 1 bar.

##### Bead

The tire bead contains steel wires wrapped by steel cords that hold the tire onto the rim.

##### Cold tire inflation pressure

Tire inflation pressure when your vehicle has been sitting for at least 3 hours or driven no more than 1 mile (1.6 km).

##### Curb weight

The weight of a motor vehicle with standard equipment including the maximum capacity of fuel, oil, and coolant, and, if so equipped, air conditioning and additional optional equipment, but without passengers and cargo.

**DOT (Department of Transportation)**

A tire branding symbol which denotes the tire meets requirements of the U.S. Department of Transportation.

**GAWR (Gross Axle Weight Rating)**

The GAWR is the maximum permissible axle weight. The gross vehicle weight on each axle must never exceed the GAWR for the front and rear axle indicated on the certification label located on the driver's door B-pillar.

**GVW (Gross Vehicle Weight)**

The GVW comprises the weight of the vehicle including fuel, tools, spare wheel, installed accessories, passengers and cargo and, if applicable, trailer tongue load. The GVW must never exceed the GVWR indicated on the certification label located on the driver's door B-pillar.

**GVWR (Gross Vehicle Weight Rating)**

This is the maximum permissible vehicle weight of the fully loaded vehicle (weight of the vehicle including all options, passengers, fuel, and cargo and, if applicable, trailer tongue load). It is indicated on certification label located on the driver's door B-pillar.

**Kilopascal (kPa)**

The metric unit for air pressure. There are 6.9 kilopascals (kPa) to 1 psi; another metric unit for air pressure is bars. There are 100 kilopascals (kPa) to 1 bar.

**Maximum load rating**

The maximum load in kilograms and pounds that can be carried by the tire.

**Maximum loaded vehicle weight**

The sum of curb weight, accessory weight, total load limit, and production options weight.

**Maximum tire inflation pressure**

This number is the greatest amount of air pressure that should ever be put in the tire under normal driving conditions.

**Normal occupant weight**

The number of occupants the vehicle is designed to seat, multiplied by 68 kilograms (150 lbs).

**Occupant distribution**

The distribution of occupants in a vehicle at their designated seating positions.

**Production options weight**

The combined weight of those installed regular production options weighing over 5 lbs (2.3 kilograms) in excess of those standard items which they replace, not previously considered in curb weight or accessory weight, including heavy duty brakes, ride levelers, roof rack, heavy duty battery, and special trim.

### Tires and wheels

#### PSI (Pounds per square inch)

A standard unit of measure for air pressure  
-> bar, kilopascal (kPa).

#### Recommended tire inflation pressure

The recommended tire inflation pressure is listed on Tire and Loading Information placard located on driver's door B-pillar for normal driving conditions and provides best handling, tread life and riding comfort. If so equipped, supplemental information pertaining to special driving situations can be found on the tire inflation pressure label on the inside of the fuel filler flap.

#### Rim

A metal support for a tire or a tire and tube assembly upon which the tire beads are seated.

#### Sidewall

The portion of a tire between the tread and the bead.

#### TIN (Tire Identification Number)

Unique identifier which facilitates efforts by tire manufacturers to notify purchasers in recall situations or other safety matters concerning tires and gives purchases the means to easily identify such tires. The TIN is comprised of "Manufacturer's identification mark", "Tire size", "Tire type code" and "Date of manufacture".

#### Tire load rating

Numerical code associated with the maximum load a tire can support.

#### Tire ply composition and material used

This indicates the number of plies or the number of layers of rubber-coated fabric in the tire tread and sidewall. Tire manufacturers also must indicate the ply materials in the tire and sidewall, which include steel, nylon, polyester, and others.

#### Tire speed rating

Part of tire designation; indicates the speed range for which a tire is approved.

#### Total load limit

Rated cargo and luggage load plus 68 kilograms (150 lbs) times the vehicle's designated seating capacity.

#### Traction

Force exerted by the vehicle on the road via the tires. The amount of grip provided.

#### Tread

The portion of a tire that comes into contact with the road.

#### Treadwear indicators

Narrow bands, sometimes called "wear bars" that show across the tread of a tire when only  $\frac{1}{16}$  in (1.6 mm) of tread remains.

### Uniform Tire Quality Grading Standards

A tire information system that provides consumers with ratings for a tire's traction, temperature and treadwear. Ratings are determined by tire manufacturers using government testing procedures. The ratings are molded into the sidewall of the tire.

### Vehicle maximum load on the tire

Load on an individual tire that is determined by distributing to each axle its share of the maximum loaded vehicle weight and dividing it by two.

### Rotating tires

#### Warning!



Rotate front and rear wheels only if the tires are of the same dimension.

If your vehicle is equipped with mixed-size tires (different tire dimensions front vs. rear), tire rotation is not possible.

Tire rotation can be performed on vehicles with tires of the same dimension all around. If your vehicle is equipped with tires of the same dimension all around, tires can be rotated, observing a front-to-rear rotation pattern that will maintain the intended rotation (spinning) direction of the tire (▷ page 334).

In some cases, such as when your vehicle is equipped with mixed-size tires (different tire dimension front vs. rear), tire rotation is not possible.

If applicable to your vehicle's tire configuration, tires can be rotated according to the tire manufacturer's recommended intervals in the tire manufacturer's warranty pamphlet located in your vehicle literature portfolio. If none is available, tires should be rotated every 3000 to 6000 miles (5000 to 10000 km), or sooner if necessary, according to the degree of tire wear. The same rotation (spinning) direction must be maintained (▷ page 334).

Rotate tires before the characteristic tire wear pattern becomes visible (shoulder wear on front tires and tread center wear on rear tires).

Thoroughly clean the mounting face of wheels and brake disks, i.e. the inner side of the wheels/tires, during each rotation. Check for and ensure proper tire inflation pressure.

#### Warning!



Have the tightening torque checked after changing a wheel. Wheels could become loose if not tightened with a torque of 96 lb-ft (130 Nm).

Only use genuine Mercedes-Benz wheel bolts specified for your vehicle's rims.

For information on wheel change, see the "Practical hints" section (▷ page 440).



### Winter driving

Before the onset of winter, have your vehicle winterized at an authorized Mercedes-Benz Center. This service includes:

- Check of anticorrosion and antifreeze concentration.
- Addition of cleaning concentrate to the water of the windshield and headlamp cleaning\* system. Add MB Windshield Washer Concentrate “MB Summerfit” to a premixed windshield washer solvent/antifreeze which is formulated for below freezing temperatures (> page 485).
- Battery test. Battery capacity drops with decreasing ambient temperature. A well charged battery helps to make sure the engine can be started, even at low ambient temperatures.
- Tire change.

### Winter tires

Always use winter tires at temperatures below 45°F (7°C) and whenever wintry road conditions prevail. Not all M+S rated tires provide special winter performance. Make sure the tires you use show the mountain/snowflake  marking on the tire sidewall. These tires meet specific snow traction performance requirements of the Rubber Manufacturers Association (RMA) and the Rubber Association of Canada (RAC) and have been designed specifically for use in snow conditions. Use of winter tires is the only way to achieve the maximum effectiveness of the ABS, EBP, ESP® and 4MATIC in winter operation.

For safe handling, make sure all mounted winter tires are of the same make and have the same tread design.

### Warning!



Winter tires with a tread depth of less than  $\frac{1}{6}$  in (4 mm) must be replaced. They are no longer suitable for winter operation.

Always observe the speed rating of the winter tires installed on your vehicle. If the maximum speed for which your tires are rated is below the speed rating of your vehicle, you must place a notice to this effect where it will be seen by the driver. Such notices are available at your tire dealer or any authorized Mercedes-Benz Center.

**Warning!**

If you use your spare tire when winter tires are fitted on the other wheels, be aware that the difference in tire characteristics may very well impair turning stability and that overall driving stability may be reduced. Adapt your driving style accordingly.

Have the spare tire replaced with a winter tire at the nearest authorized Mercedes-Benz Center.

**Snow chains**

**!** *Some tire sizes do not leave adequate clearance for snow chains. To help avoid serious damage to your vehicle or tires, make sure that the use of snow chains is permissible as specified in the Technical data section of this Operator's Manual, see "Rims and tires" (▷ page 467).*

Snow chains should only be driven on snow-covered roads at speeds not to exceed 30 mph (50 km/h). Remove chains as soon as possible when driving on roads without snow.

Please observe the following guidelines when using snow chains:

- Use of snow chains is not permissible with all wheel/tire combinations (▷ page 467).
- Use snow chains in pairs and on rear wheels only. Follow the manufacturer's mounting instructions.

**!** *If snow chains are mounted to the front wheels, they may scrape against the body or axle components. The tires or the vehicle could be damaged as a result.*

- Only use snow chains that are approved by Mercedes-Benz. Any authorized Mercedes-Benz Center will be glad to advise you on this subject.
- Use of snow chains may be prohibited depending on location. Always check local and state laws before installing snow chains.
- Do not use snow chains on the spare wheel (▷ page 467).

**i** *When driving with snow chains, you may wish to deactivate the ESP® (▷ page 63) before setting the vehicle in motion. This will improve the vehicle's traction.*

We strongly recommend that you have your vehicle serviced at an authorized Mercedes-Benz Center, in accordance with the Maintenance Booklet at the times called for by the maintenance service indicator.

**!** Failure to have the vehicle maintained in accordance with the Maintenance Booklet and maintenance service indicator at the designated times/mileage will result in vehicle damage not covered by the Mercedes-Benz Limited Warranty.

### Maintenance service indicator message

The maintenance service indicator message will notify you when the next maintenance service is due.

Starting approximately 1 month before the next maintenance service is due, one of the following messages will appear in the multifunction display while you are driving or when you switch on the ignition (example service A):

Next Service A Due in XXXX miles (km)  
Next Service A Due in XXX days  
Service A Due



The type of maintenance service due is indicated in the message that appears in the multifunction display:

- A Basic service  
(approximately 1 hour)
- B Extended service  
(approximately 8 hours)

An additional number or a further letter in combination with the maintenance type can be indicated. This indicates that further auxiliary maintenance work is required. Contact an authorized Mercedes-Benz Center for more information.

**i** The Maintenance System in your vehicle tracks distance driven and the time elapsed since the last maintenance service and calculates other maintenance service work required.

**i** The maintenance service indicator message is automatically cleared

- after approximately 10 seconds when you switch on the ignition or when reaching the maintenance service threshold while driving
- after approximately 30 seconds, once the suggested maintenance service term has passed

You can also clear it yourself.

► **To clear the maintenance service indicator message:** Press button **←** or button **OK** on the multifunction steering wheel (▷ page 152).

The maintenance service indicator message is cleared and the standard display appears in the multifunction display (▷ page 151).

### Maintenance service term exceeded

If you have exceeded the suggested maintenance service term, you will see the following message in the multifunction display:

Service A Exceeded by XXXX miles (km)  
Service A Exceeded by XXX days

In addition, a signal sounds when the message appears.

Any authorized Mercedes-Benz Center will reset the maintenance service indicator following a completed maintenance service.

### Calling up the maintenance service indicator display

**i** The menu overview can be found on (▷ page 154).

You can call up the maintenance service indicator display at any time to check when the next maintenance service is due.

- ▶ Switch on the ignition.  
The standard display of the control system appears (▷ page 156).
  - ▶ Press **◀** or **▶** on multifunction steering wheel to select Service menu.
  - ▶ Press **▼** or **▲** to select the maintenance service indicator display.
  - ▶ Press **OK**.
- The service deadline appears in the multifunction display.

**i** *If the battery is disconnected, the days of disconnection will not be included in the count shown by the maintenance service indicator. To arrive at the true maintenance service deadline, you will need to subtract these days from the days shown in the maintenance service indicator message or maintenance service indicator display.*

### Resetting the maintenance service indicator

In the event that the maintenance service on your vehicle is not carried out at an authorized Mercedes-Benz Center, you can have the maintenance service indicator reset. The automotive maintenance facility carrying out the maintenance service will find the information for resetting the maintenance service indicator in the maintenance-relevant information for your vehicle. Such information is available from either your authorized Mercedes-Benz Center or directly from Mercedes-Benz.

**i** *If the maintenance service indicator was inadvertently reset, have an authorized Mercedes-Benz Center correct it.*

*Only reset if the proper maintenance service has been performed. Resetting the system without performing the proper service as called for by the maintenance service indicator will result in engine damage and/or other vehicle damage not covered by the Mercedes-Benz Limited Warranty.*

### Cleaning and care of vehicle

Regular and proper care will help to maintain the value of your vehicle. The best way to protect your vehicle from harmful environmental influences is to wash it and use protective treatments regularly.

#### Warning!



Many cleaning products can be hazardous. Some are poisonous, others are flammable. Always follow the instructions on the particular container. Always open your vehicle's doors or windows when cleaning the inside.

Never use fluids or solvents that are not designed for cleaning your vehicle.

Always lock away cleaning products and keep them out of reach of children.

While in operation, even while parked, your vehicle is subjected to varying external influences which, if gone unchecked, can attack the paintwork as well as the vehicle underbody and cause lasting damage.

Such damage is caused not only by extreme and varying climatic conditions, but also by:

- Air pollution
- Road salt
- Tar
- Gravel and stone chipping

To avoid paint damage, you should immediately remove:

- Grease and oil
- Fuel
- Coolant
- Brake fluid
- Bird droppings
- Insects
- Tree resins, etc.

Frequent washing reduces and/or eliminates the aggressiveness and potency of the above adverse influences.

More frequent washings are necessary to deal with unfavorable conditions:

- near the ocean
- in industrial areas (smoke, exhaust emissions)
- during winter operation

You should check your vehicle from time to time for stone chipping or other damage. Any damage should be repaired as soon as possible to prevent corrosion.

In doing so, do not neglect the underbody of the vehicle. A prerequisite for a thorough check is a washing of the underbody followed by a thorough inspection. Damaged areas need to be re-undercoated.

Your vehicle has been treated at the factory with a wax-base rustproofing in the body cavities which will last for the lifetime of the vehicle. Post-production treatment is neither necessary nor recommended by Mercedes-Benz because of the possibility

of incompatibility between materials used in the production process and others applied later.

We have selected car-care products and compiled recommendations which are specially matched to our vehicles and which always reflect the latest technology. You can obtain Mercedes-Benz approved car-care products at an authorized Mercedes-Benz Center.

Scratches, corrosive deposits, corrosion or damage due to negligent or incorrect care cannot always be removed or repaired with the car-care products recommended here. In such cases it is best to seek aid at an authorized Mercedes-Benz Center.

The following topics deal with the cleaning and care of your vehicle and give important “how-to” information as well as references to Mercedes-Benz approved car-care products.

### Power washer

**!** Follow the instructions provided by the power washer manufacturer on maintaining a distance between the vehicle and the nozzle of the power washer.

*Never use a round nozzle to power-wash tires. The intense jet of water can result in damage to the tire.*

*Always replace a damaged tire.*

*Always keep the jet of water moving across the surface. Do not aim directly at electrical parts, electrical connectors, seals, or other rubber parts.*

**i** Vehicles with KEYLESS-GO\*: *If a door handle is hit by a strong jet of water, and a SmartKey with KEYLESS-GO\* is in close proximity, i.e. within approximately 3 ft (approximately 1 m), the vehicle could be inadvertently locked or unlocked.*

### Tar stains

Quickly remove tar stains before they dry and become more difficult to remove. A tar remover is recommended.

### Paintwork, painted body components

**!** Affixing stickers, magnets, adhesive tape or similar materials to painted body components may damage the paintwork.

Mercedes-Benz approved Paint Care should be applied when water drops on the paint surface do not “bead up”. This should normally be done every 3 to 5 months, depending on the climate and washing detergent used.

Mercedes-Benz approved Paint Cleaner should be applied if the paint surface shows signs of embedded dirt (i.e. loss of gloss).

Do not apply any of these products or wax if your vehicle is parked in the sun or if the hood is still hot.

- ▶ Use the appropriate MB-Touch-Up Stick for quick and provisional repairs of minor paint damage (i.e. chips from stones, vehicle doors, etc.).

### Vehicle care

#### Engine cleaning

Prior to cleaning the engine compartment, make sure to protect electrical components and connectors from contact with water and cleaning agents.

Corrosion protection, such as MB Anticorrosion Wax, should be applied to the engine compartment after every engine cleaning. Before applying, all control linkage bushings and joints should be lubricated. The poly-V-belt and all pulleys should be protected from any wax.

#### Vehicle washing

In the winter, thoroughly remove all traces of road salt as soon as possible.

When washing the vehicle underbody, do not forget to clean the inner sides of the wheels.

**i** *Vehicles with KEYLESS-GO\* (Canada only): If a door handle is hit by a strong jet of water, and a SmartKey with KEYLESS-GO\* is in close proximity, i.e. within approximately 3 ft (approximately 1 m), the vehicle could be inadvertently locked or unlocked.*

#### Hand-wash

Do not use hot water or wash your vehicle in direct sunlight.

- ▶ Only use a mild car wash detergent, such as Mercedes-Benz approved Car Shampoo.
  - ▶ Thoroughly spray the vehicle with a diffused jet of water.
- Direct only a very weak spray towards the ventilation intake.
- ▶ Use plenty of water and rinse the sponge and chamois frequently.
  - ▶ Rinse with clean water and thoroughly dry with a chamois.

Do not allow cleaning agents to dry on the finish.

**!** *Do not use scouring agents on these parts. Never apply strong force and only use a soft, non-scratching cloth when cleaning the vehicle. Do not attempt to wipe the surface with a dry cloth or sponge.*

*Otherwise you may scratch or damage the paint.*

### Automatic car wash

You can have your car washed in an automatic car wash from the start. Automatic car washes without brushes are preferable.

- ▶ To protect the filter system, switch the automatic climate control to air recirculation mode (▷ page 265).

**!** Do not clean your vehicle in an automatic touchless car wash which uses caustic spray. Otherwise the caustic spray will damage the paint or ornamental moldings.

If the vehicle is very dirty, prewash it before running it through the automatic car wash.

**!** Make sure the windshield wiper switch is set to **0** (▷ page 117). Otherwise, e.g. the rain sensor\* could activate and cause the wipers to move unintentionally. This may lead to vehicle damage.

Due to the width of the vehicle, fold in exterior rear view mirrors prior to running the vehicle through an automatic car wash to prevent damage to the mirrors.

**i** After running the vehicle through an automatic car wash, wipe any wax off of the windshield (▷ page 368). This will prevent smears and reduce wiping noise which can be caused by residual wax on the windshield.

When leaving the car wash, make sure the mirrors are folded out. Otherwise they may vibrate.

### Ornamental moldings

For regular cleaning and care of ornamental moldings, use a damp cloth.

**!** Do not use chrome cleaner on ornamental moldings. Although ornamental moldings may have chrome appearance, they could be made of anodized aluminum that will be damaged when cleaned with chrome cleaner. Instead, use a damp cloth to clean those ornamental moldings.

For very dirty ornamental moldings of which you are sure are chrome-plated, use a chrome cleaner. If in doubt whether an ornamental molding is chrome-plated, contact an authorized Mercedes-Benz Center.

### Headlamps, tail lamps, side markers, turn signal lenses

- ▶ Use a mild car wash detergent, such as Mercedes-Benz approved Car Shampoo, with plenty of water.

**!** Only use window cleaning solutions that are suitable for plastic lamp lenses. Window cleaning solutions which are not suitable may damage the plastic lamp lenses of the headlamps. Therefore, do not use abrasives, solvents or cleaners that contain solvents.

Never apply strong force and only use a soft, non-scratching cloth when cleaning the lenses. Do not attempt to wipe dirty lenses with a dry cloth or sponge.

Otherwise you may scratch or damage the lens surface.



## Vehicle care

### Cleaning the windows and the wiper blades

**!** *The windshield wipers must be in a vertical position before folding them away from the windshield. They could otherwise damage the hood.*

*Never open the hood when the wiper arms are folded forward.*

- ▶ Make sure the hood is fully closed.

### Placing wiper arms in vertical position

Vehicles with SmartKey:

- ▶ Turn SmartKey in starter switch position **1**.
- ▶ Turn combination switch to wiper setting  (▷ page 117).
- ▶ With wiper arm in vertical position, turn the SmartKey in starter switch to position **0**.

Vehicles with KEYLESS-GO\* (Canada only):

- ▶ Make sure the vehicle's on-board electronics have status **1** (▷ page 84).
- ▶ Turn combination switch to wiper setting  (▷ page 117).
- ▶ Press KEYLESS-GO start/stop button repeatedly until windshield wipers start.
- ▶ Press KEYLESS-GO start/stop button when the wiper arms are in a vertical position.

### Cleaning

#### Warning!



For safety reasons, switch off wipers and remove SmartKey from starter switch (vehicles with KEYLESS-GO\* (Canada only): Make sure the vehicle's on-board electronics have status **0**) before cleaning the windshield and/or the wiper blades. Otherwise, the wiper motor could suddenly turn on and cause injury.

- ▶ Fold the wiper arms forward until they snap into place.
- !** *Do not pull on the wiper blade inserts. They could tear.*
- ▶ Clean the wiper blade inserts with a clean cloth and detergent solution.
- ▶ Use a soft, clean cloth and a mild window cleaning solution on all outside and inside glass surfaces.

An automotive glass cleaner is recommended.

**!** Fold the windshield wiper arms back onto the windshield before turning the SmartKey in the starter switch or pressing the KEYLESS-GO\* start/stop button (vehicles with KEYLESS-GO\* (Canada only)).

*Hold on to the wiper when folding the wiper arm back. If released, the force of the impact from the tensioning spring could crack the windshield.*

**!** To clean the window interior, do not use a dry cloth, abrasives, solvents or cleaners containing solvents. Do not touch the inside of the front, rear or side windows with hard objects such as an ice scraper or ring. Doing so may damage the windows.

### **Cleaning the panorama roof with tilt/sliding panel\***

The rear part of the tilt/sliding panel has a protective layer on the inside.

- ▶ Use a soft, clean cloth and a mild window cleaning solution.

An automotive glass cleaner is recommended.

**!** Do not use a dry cloth, abrasives, solvents or cleaners containing solvents. Do not touch the protective layer with hard objects such as an ice scraper or ring. Never apply strong force and only use a soft, non-scratching cloth when cleaning the rear part of the tilt/sliding panel.

*Otherwise you may scratch or damage the protective layer.*

### **Chrome-plated exhaust tip\***

Regular cleaning and care of chrome-plated exhaust tips will help to maintain their shine and the classy appearance.

- ▶ Use Mercedes-Benz approved Chrome Polishing Paste each time the vehicle has been washed, especially during the winter.

**!** Do not use alkaline cleaners such as wheel cleaners as they could cause corrosion.

## Vehicle care

### Light alloy wheels

If possible, clean wheels once a week.

- ▶ Use Mercedes-Benz approved Wheel Care, a soft bristle brush and a strong spray of water for cleaning the light alloy wheels.

**!** Only use acid-free cleaning materials. Acid may cause corrosion or damage the clear coat.

**!** The vehicle should not be parked for an extended period of time immediately after it has been cleaned, especially not after the wheel rims have been cleaned with wheel rim cleaner.

Wheel rim cleaners can lead to increased corrosion of the brake disks and brake pads. Non-approved wheel cleaners may also damage the wheel paint if the car is not driven after cleaning.

Therefore, the vehicle's brake system should always be warmed-up before it is parked after cleaning. To do so, please drive your vehicle for several minutes to allow the brakes to dry. When applying Mercedes-Benz approved Tire Care and Mercedes-Benz approved Wheel Care products, take care not to spray them on the brake disks.

### Plastic and rubber parts

- ▶ Use a gentle dishwashing detergent or mild detergent for delicate fabrics as a washing solution.
- ▶ Wipe with a cloth moistened in a luke-warm solution.

The surface may temporarily change color. If this is the case, wait for it to dry.

#### Warning!



Do not use cleaners or cockpit care sprays containing solvents to clean the cockpit or the steering wheel. Cleaners containing solvents will make the surface porous and vehicle occupants could suffer serious injuries from plastic parts coming loose in the event of air bag deployment.

**!** Do not use oil, wax or scouring agents on these parts.

Never apply strong force and only use a soft, non-scratching cloth when cleaning the surface. Do not attempt to wipe the surface with a dry cloth or sponge.

Otherwise you may scratch or damage the surface.

### Hard plastic trim items

- ▶ Use Mercedes-Benz approved Interior Care, a soft, lint-free cloth and apply with light pressure.

**!** Never apply strong force and only use a soft, non-scratching cloth when cleaning the surface. Do not attempt to wipe the surface with a dry cloth or sponge.

Otherwise you may scratch or damage the surface.

### Audio display

**!** *You must switch off the audio display and allow it to cool prior to cleaning.*

- ▶ If you need to clean the audio display screen, use a standard microfiber cloth and cleaning agent for TFT/LCD displays. After cleaning, dry and polish the screen with a dry microfiber cloth.

**!** *Do not use thinners containing alcohol, petrol or abrasive cleaning agents. These can damage or even destroy the audio display screen.*

### Steering wheel

- ▶ Wipe with a damp cloth and dry thoroughly or clean with Mercedes-Benz approved Leather Care.

### Carpets

- ▶ Use Mercedes-Benz approved Carpet and Fabric Care for cleaning the carpets.

### Headliner and shelf below rear window

- ▶ Use a soft bristle brush or a dry-shampoo cleaner in case of excessive dirt.

### Seat belts

- ▶ Only use clear, lukewarm water and soap.

**!** *The webbing must not be treated with chemical cleaning agents. Do not dry the webbing at temperatures above 176 °F (80 °C) or in direct sunlight.*

#### Warning!



Do not bleach or dye seat belts as this may severely weaken them. In a crash they may not be able to provide adequate protection.

### Vehicle care

#### Upholstery

Using aftermarket seat covers or wearing clothing that have the tendency to give off coloring (e.g. when wet, etc.) may cause the upholstery to become permanently discolored. By lining the seats with a proper intermediate cover, contact-discoloration will be prevented.

#### Warning!



Only use seat or head restraint covers which have been tested and approved by Mercedes-Benz for your vehicle model. Using other seat or head restraint covers may interfere with or prevent the activation of the active head restraints.

Contact an authorized Mercedes-Benz Center for availability.

#### Leather upholstery

- ▶ Wipe leather upholstery with a damp cloth and dry thoroughly or clean with Mercedes-Benz approved Leather Care.

Exercise particular care when cleaning perforated leather as its underside should not become wet.

#### Wood trims

- ▶ Dampen cloth using water and use damp cloth to clean wood trims in your vehicle.

**!** *Do not use solvents like tar remover or wheel cleaner nor polishes or waxes as these may be abrasive.*

**What to do if ...?**

**Where will I find ...?**

**Unlocking/locking in an emergency**

**Resetting activated head restraints**

**Replacing SmartKey batteries**

**Replacing bulbs**

**Replacing wiper blades**

**Flat tire**

**Battery**

**Jump starting**

**Towing the vehicle**

**Fuses**





### What to do if ...?

#### Lamps in instrument cluster

General information:





If any of the following lamps in the instrument cluster fails to come on during the bulb self-check when switching on the ignition, have the respective bulb checked and replaced if necessary.

Problem	Possible cause/consequence	Suggested solution
 The yellow Antilock Brake System (ABS) indicator lamp comes on while the engine is running.	<p>The ABS has detected a malfunction and has switched off. The BAS, ESP® and EBP are also switched off (see messages in multifunction display).</p> <p>The brake system is still functioning normally but without the systems specified above.</p> <p>If the ABS control unit is malfunctioning, other systems such as navigation system* or the automatic transmission* may also be malfunctioning.</p>	<ul style="list-style-type: none"><li>▶ Continue driving with added caution. Wheels will lock during hard braking, reducing steering capability.</li><li>▶ Read and observe messages in the multifunction display (▷ page 387).</li><li>▶ Have the system checked at an authorized Mercedes-Benz Center as soon as possible.</li></ul> <p>Failure to follow these instructions increases the risk of an accident.</p>

Problem	Possible cause/consequence	Suggested solution
 <p>The yellow Antilock Brake System (ABS) indicator lamp comes on while the engine is running.</p>	<p>The charging voltage has fallen below 10 volts. The ABS has switched off. The BAS, ESP® and EBP are also switched off (see messages in the multifunction display)</p> <p>The battery may not be charged sufficiently.</p>	<ul style="list-style-type: none"> <li>▶ Switch off electrical consumers that are currently not needed, e.g. seat heating*.</li> <li>▶ If necessary, have the generator and battery checked.</li> </ul> <p>When the voltage is above this value again, the ABS is operational again and the ABS indicator lamp should go out.</p>
 <p>The yellow ABS indicator lamp comes on while the engine is running.</p>	<p>The ABS is temporarily not available. The ESP®, BAS and EBP are also unavailable.</p> <p>The system's self-diagnosis may not be completed yet.</p> <p>The brake system is still functioning normally but without the systems specified above.</p>	<ul style="list-style-type: none"> <li>▶ Drive a short distance with added caution at a vehicle speed of above 12 mph (20 km/h).</li> </ul> <p>When the ABS indicator lamp goes out, the ABS, ESP®, BAS and EBP are available again.</p> <p>If the ABS indicator lamp does not go out:</p> <ul style="list-style-type: none"> <li>▶ Continue driving with added caution.</li> <li>▶ Have the system checked at an authorized Mercedes-Benz Center as soon as possible.</li> </ul> <p>Failure to follow these instructions increases the risk of an accident.</p>



### What to do if ...?

Problem	Possible cause/consequence	Suggested solution
  <p>The yellow ABS malfunction indicator lamp and the yellow ESP<sup>®</sup> warning lamp come on while the engine is running and an acoustic warning sounds.</p>	<p>ABS and ESP<sup>®</sup> are switched off due to a malfunction.</p> <p>The BAS and EBP are also switched off.</p> <p>The brake system is still functioning normally but without the ABS available.</p>	<ul style="list-style-type: none"> <li>▶ Continue driving with added caution. Wheels may lock during hard braking, reducing steering capability.</li> <li>▶ Read and observe messages in the multifunction display (▷ page 387).</li> <li>▶ Have the system checked at an authorized Mercedes-Benz Center as soon as possible.</li> </ul> <p>Failure to follow these instructions increases the risk of an accident.</p>
<p><b>BRAKE</b> (USA only)</p>  <p>(Canada only)</p>   <p>The red brake warning lamp comes on while the engine is running. In addition, the yellow ABS malfunction indicator lamp, and the yellow ESP<sup>®</sup> warning lamp come on and an acoustic warning sounds.</p>	<p>A malfunction in the Electronic Brake Proportioning (EBP) was detected. The ABS, BAS and ESP<sup>®</sup> are also switched off (see messages in multifunction display).</p> <p>The brake system continues to function normally, but without electronic support.</p>	<ul style="list-style-type: none"> <li>▶ Continue driving with added caution. Wheels may lock during hard braking, reducing steering capability.</li> <li>▶ Read and observe messages in the multifunction display (▷ page 387).</li> <li>▶ Have the system checked at an authorized Mercedes-Benz Center as soon as possible.</li> </ul> <p>Failure to follow these instructions increases the risk of an accident.</p>

Problem	Possible cause/consequence	Suggested solution
<p><b>BRAKE</b> (USA only)</p> <p> (Canada only)</p> <p>The red brake warning lamp comes on while the engine is running and an acoustic warning sounds.</p>	<p>You are driving with the parking brake set.</p>	<p>▶ Release the parking brake (▷ page 130).</p>
<p>The red brake warning lamp comes on while the engine is running.</p>	<p>There is insufficient brake fluid in the reservoir.</p>	<p>Risk of accident!</p> <ul style="list-style-type: none"> <li>▶ Carefully stop the vehicle in a safe location or as soon as it is safe to do so.</li> <li>▶ Depress the parking brake (▷ page 134).</li> <li>▶ Contact an authorized Mercedes-Benz Center.</li> <li>▶ Do not add brake fluid! This will not solve the problem.</li> </ul>

**Warning!**



Driving with the brake warning lamp illuminated can result in an accident. Have your brake system checked immediately if the brake warning lamp stays on.

Do not add brake fluid before checking the brake system.



Overfilling the brake fluid reservoir can result in spilling brake fluid on hot engine parts and the brake fluid catching fire. You can be seriously burned.

**!** *If you find that the brake fluid in the brake fluid reservoir has fallen to the minimum mark or below, have the brake system checked for brake pad thickness and leaks.*



### What to do if ...?



Problem	Possible cause/consequence	Suggested solution
 <p>The yellow engine malfunction indicator lamp comes on while driving.</p>	<p>There is a malfunction in:</p> <ul style="list-style-type: none"><li>• The fuel management system</li><li>• The ignition system</li><li>• The emission control system</li><li>• Systems which affect emissions</li></ul> <p>Such malfunctions may result in excessive emissions values and may switch the engine to its limp-home (emergency operation) mode.</p>	<p>► Have the vehicle checked as soon as possible at an authorized Mercedes-Benz Center.</p> <p>An on-board diagnostic connector is used by the service station to link the vehicle to the shop diagnostics system. It allows the accurate identification of system malfunctions through the read-out of diagnostic trouble codes. It is located in the front left area of the footwell next to the parking brake pedal.</p>

**i** *In some states you may be required by law to have the vehicle serviced as soon as the engine malfunction indicator lamp comes on. Check local requirements.*

Problem	Possible cause/consequence	Suggested solution
 <p>The yellow engine malfunction indicator lamp comes on while driving.</p>	<p>A loss of pressure has been detected in the fuel system. The fuel cap may not be closed properly or the fuel system may be leaky.</p>	<ul style="list-style-type: none"> <li>▶ Check the fuel cap.</li> </ul> <p>If it is not closed properly:</p> <ul style="list-style-type: none"> <li>▶ Close the fuel cap.</li> </ul> <p>If it is closed properly:</p> <ul style="list-style-type: none"> <li>▶ Have the fuel system checked at an authorized Mercedes-Benz Center.</li> </ul>
 <p>The yellow ESP® warning lamp comes on while the engine is running.</p>	<p>The ESP® has been switched off with the ESP® switch or has been switched off due to a malfunction.</p> <p>Risk of accident!</p> <p>When the ESP® is switched off it will not stabilize the vehicle if the system recognizes that the vehicle starts to skid or that a wheel is spinning.</p> <p>The cruise control is deactivated and cannot be switched on.</p>	<ul style="list-style-type: none"> <li>▶ Switch the ESP® back on (▷ page 64). Exceptions: (▷ page 63).</li> <li>▶ If leaving the ESP® switched off, adapt your speed and driving to the prevailing road, weather and traffic conditions.</li> </ul> <p>If the ESP® cannot be switched on:</p> <ul style="list-style-type: none"> <li>▶ Continue driving with added caution.</li> <li>▶ Observe additional messages that may appear in the multifunction display (▷ page 389).</li> <li>▶ Have the system checked at an authorized Mercedes-Benz Center as soon as possible.</li> </ul>

### What to do if ...?

Problem	Possible cause/consequence	Suggested solution
 <p>The yellow ESP® warning lamp flashes while driving.</p>	<p>The ESP® or traction system has come into operation because of detected traction loss in at least one tire.</p> <p>The cruise control is deactivated.</p>	<ul style="list-style-type: none"> <li>▶ When driving off, apply as little throttle as possible.</li> <li>▶ While driving, ease up on the accelerator.</li> <li>▶ Adapt your speed and driving to the prevailing road, weather and traffic conditions.</li> <li>▶ Do not deactivate the ESP®. Exceptions: (▷ page 63).</li> </ul> <p>Failure to follow these instructions increases the risk of an accident.</p>
 <p>The yellow fuel tank reserve warning lamp in the fuel gauge comes on while driving.</p>	<p>The fuel level has gone below the reserve mark.</p>	<ul style="list-style-type: none"> <li>▶ Refuel at the next gas station (▷ page 322).</li> </ul>
 <p>The red seat belt telltale comes on for a maximum of 6 seconds after starting the engine.</p>	<p>The seat belt telltale reminds you and your passengers to fasten your seat belts before driving off.</p>	<ul style="list-style-type: none"> <li>▶ Fasten your seat belts.</li> </ul> <p>Regardless of whether the seat belts are fastened or not, the seat belt telltale always comes on and remains lit for 6 seconds after starting the engine.</p>

Problem	Possible cause/consequence	Suggested solution
 You hear a warning chime for a maximum of 6 seconds after starting the engine.	You have forgotten to fasten your seat belt.	▶ Fasten your seat belt. The warning chime stops sounding.
 The red seat belt telltale comes on while the vehicle is standing still and the engine is running or during driving.	You and/or your front passenger have forgotten to fasten your seat belts.	▶ Fasten your seat belts. The seat belt telltale goes out.
	There are items placed on the front passenger seat and therefore the system senses the front passenger seat as being occupied.	▶ Remove the items from the front passenger seat and put them in a safe place. The seat belt telltale goes out.
 During driving the red seat belt telltale flashes and you additionally hear an intermittent warning chime with increasing intensity.	The vehicle's speed has exceeded 15 mph (25 km/h) and you and/or your front passenger have forgotten to fasten your seat belts.	▶ Fasten your seat belts. The seat belt telltale goes out and the warning chime stops sounding.
	There are items placed on the front passenger seat and therefore the system senses the front passenger seat as being occupied.	▶ Remove the items from the front passenger seat and put them in a safe place. The seat belt telltale goes out and the warning chime stops sounding.

 After 60 seconds with an unfastened seat belt the warning chime stops sounding and the seat belt telltale illuminates continuously.

*The seat belt telltale will only go out if both, the driver's and front passenger's seat belt are fastened,*

*or the vehicle is standing still and a front door is opened.*



### What to do if ...?

Problem	Possible cause/consequence	Suggested solution
 The red SRS indicator lamp comes on while driving.	There is a malfunction in the supplemental restraint systems. The air bags or Emergency Tensioning Devices (ETDs) could deploy unexpectedly or fail to activate in an accident.	► Drive with added caution to the nearest authorized Mercedes-Benz Center.

#### Warning!



In the event a malfunction of the SRS is indicated as outlined above, the SRS may not be operational. For your safety, we strongly recommend that you contact an authorized Mercedes-Benz Center immediately to have the system checked; otherwise the SRS may not be deployed when needed in an accident, which could result in serious or fatal injury, or it might deploy unexpectedly and unnecessarily which could also result in an accident and/or injury to you or to others.

Problem	Possible cause/consequence	Suggested solution
 <p>Combination low tire pressure/TPMS malfunction telltale for the TPMS illuminates continuously.</p>	<p>The TPMS detects a loss of pressure in at least one tire.</p>	<ul style="list-style-type: none"> <li>▶ Carefully bring the vehicle to a halt, avoiding abrupt steering and braking maneuvers. Observe the traffic situation around you.</li> <li>▶ Read and observe messages in the multifunction display.</li> </ul> <p>If the tire inflation pressure in the respective tire(s) has (have) been corrected, the combination low tire pressure/TPMS malfunction telltale goes out after few minutes driving.</p>
 <p>Combination low tire pressure/TPMS malfunction telltale for the TPMS flashes 60 seconds and then stays illuminated.</p>	<p>There is a malfunction in the TPMS.</p>	<ul style="list-style-type: none"> <li>▶ Read and observe messages in the multifunction display.</li> <li>▶ Have the TPMS checked at an authorized Mercedes-Benz Center.</li> </ul> <p>After the malfunction has been remedied the combination low tire pressure/TPMS malfunction telltale goes out after few minutes driving.</p>



### What to do if ...?

#### Warning!



Each tire, including the spare (if provided), should be checked monthly when cold and inflated to the inflation pressure recommended by the vehicle manufacturer on the Tire and Loading Information placard on the driver's door B-pillar (▷ page 334) or, if available, the tire inflation pressure label on the inside of the fuel filler flap (▷ page 322). If your vehicle has tires of a different size than the size indicated on the Tire and Loading Information placard or the tire inflation pressure label, you should determine the proper tire inflation pressure for those tires.

As an added safety feature, your vehicle has been equipped with a tire pressure monitoring system (TPMS) that illuminates a low tire pressure telltale when one or more of your tires is significantly underinflated. Accordingly, when the low tire pressure telltale illuminates, you should stop and check your tires as soon as possible, and inflate them to the proper pressure. Driving on a significantly underinflated tire causes the tire to overheat and can lead to tire failure.

Underinflation also reduces fuel efficiency and tire tread life, and may affect the vehicle's handling and stopping ability. Please note that the TPMS is not a substitute for proper tire maintenance, and it is the driver's responsibility to maintain correct tire pressure, even if underinflation has not reached the level to trigger illumination of the TPMS low tire pressure telltale.

Your vehicle has also been equipped with a TPMS malfunction indicator to indicate when the system is not operating properly. The TPMS malfunction indicator is combined with the low tire pressure telltale. When the system detects a malfunction, the telltale will flash for approximately 1 minute and then remain continuously illuminated. This sequence will continue upon subsequent vehicle start-ups as long as the malfunction exists. When the malfunction indicator is illuminated, the system may not be able to detect or signal low tire pressure as intended.

TPMS malfunctions may occur for a variety of reasons, including the installation of replacement or alternate tires or wheels on the vehicle that prevent the TPMS from functioning properly. Always check the TPMS malfunction telltale after replacing one or more tires or wheels on your vehicle to ensure that the replacement or alternate tires and wheels allow the TPMS to continue to function properly.

## Air bag off indicator lamp

Problem	Possible cause/consequence	Suggested solution
 <p>The front passenger front air bag off indicator lamp illuminates and remains illuminated with the weight of a typical adult or someone larger than a small individual on the front passenger seat.</p>	<p>The system is malfunctioning.</p>	<ul style="list-style-type: none"> <li>▶ Have the system checked as soon as possible at an authorized Mercedes-Benz Center.</li> <li>▶ Also read and observe any messages in the multifunction display and follow corrective steps (▷ page 387).</li> </ul>

### Warning!



If the  and remains illuminated with the weight of a typical adult or someone larger than a small individual on the front passenger seat, do not have any passenger use the front passenger seat until the system has been repaired.

### What to do if ...?

Problem	Possible cause/consequence	Suggested solution
 <p>The front passenger front air bag off indicator lamp does not illuminate and/or does not remain illuminated with the weight of a typical 12-month-old child in a standard child restraint or less on the front passenger seat.</p>	<p>The system is malfunctioning.</p>	<ul style="list-style-type: none"> <li>▶ Make sure there is nothing between seat cushion and child seat and check installation of the child seat.</li> <li>▶ Make sure no objects applying supplemental weight onto the seat are present.</li> <li>▶ If the front passenger front air bag off indicator lamp remains out, have the system checked as soon as possible at an authorized Mercedes-Benz Center. Do not transport a child on the front passenger seat until the system has been repaired.</li> <li>▶ Also read and observe any messages in the multifunction display and follow corrective steps (▷ page 387).</li> </ul>

### Warning!



If the  indicator lamp does not illuminate or remains out with the weight of a typical 12-month-old child in a standard

child restraint or less on the front passenger seat, do not transport a child on the front passenger seat until the system has been repaired.

## Vehicle status messages in the multifunction display

Warning and malfunction messages appear in the multifunction display located in the instrument cluster.

Certain warning and malfunction messages are accompanied by an audible signal.

High-priority messages are shown in red on the multifunction display. Messages of lower priority are also shown in yellow or white.

Address these messages accordingly and follow the additional instructions given in this Operator's Manual.

Certain messages of high priority cannot be cleared from the multifunction display using **OK** or  on the multifunction steering wheel (▷ page 152).

Other messages of high priority and messages of less immediate priority can be cleared from the multifunction display using **OK** or . They are then stored in the vehicle status message memory (▷ page 164). Remember that clearing a message will only make the message disappear. Clearing a message will not correct the condition that caused the message to appear.

### Warning!



No messages will be displayed if either the instrument cluster or the multifunction display is inoperative.

As a result, you will not be able to see information about your driving conditions, such as speed or outside temperature, warning/indicator lamps, malfunction/warning messages or the failure of any systems. Driving characteristics may be impaired.

If you must continue to drive, please do so with added caution. Contact an authorized Mercedes-Benz Center as soon as possible.

### What to do if ...?

#### Warning!



All categories of messages contain important information which should be taken note of and, where a malfunction is indicated, addressed as soon as possible at an authorized Mercedes-Benz Center.

Failure to repair condition noted may cause damage not covered by the Mercedes-Benz Limited Warranty, or result in property damage or personal injury.

**i** *Switching on the ignition causes all instrument cluster lamps (except high beam headlamp indicator lamp and turn signal indicator lamps unless activated) as well as the multifunction display to come on. Make sure the lamps and multifunction display are in working order before starting your journey.*

On the pages that follow, you will find a compilation of the most important warning and malfunction messages that may appear in the malfunction display.

For your convenience the messages are divided into two sections:

- Text messages (▷ page 389)
- Symbol messages (▷ page 397)

Text messages

Display	Possible cause/consequence	Possible solution
ABS and ESP Currently Unavailable See Operator's Manual	ABS and ESP® are not available due to a malfunction. BAS and the hill start assist are also switched off. It is possible that the self-diagnostics have not yet been completed.  The brake system still functions normally.	► Drive a short distance with gentle turns above a speed of 12 mph (20 km/h).  The message disappears when ABS and ESP® are again available.
	The ABS and ESP® were deactivated because of insufficient power supply. The charging voltage has fallen below 10 volts. BAS and the hill start assist are also deactivated.  The brake system still functions normally but without the ABS and ESP® available.	When the voltage is above this value again, the ABS and ESP® are operational again and the message in the multifunction display should disappear.  If the message in the multifunction display does not disappear:  ► Have the generator (alternator) and the battery checked.
ABS and ESP Inoperative See Operator's Manual	ABS and ESP® are switched off due to a malfunction. BAS and the hill start assist are also switched off.  The brake system still functions normally but without the ABS and ESP® available.	► Continue driving with added caution. Wheels may lock during hard braking, reducing steering capability.  ► Have the system checked at an authorized Mercedes-Benz Center as soon as possible.  Failure to follow these instructions increases the risk of an accident.

### What to do if ...?

Display	Possible cause/consequence	Possible solution
Cruise control - - - mph (USA only)	You have tried to switch on cruise control below a speed of 20 mph (30 km/h).	▶ If traffic conditions allow, drive faster than 20 mph (30 km/h) and save the speed.
Cruise control - - - km/h (Canada only)	The automatic transmission* is in position <b>P</b> , <b>R</b> or <b>N</b> .	▶ Move the gear selector lever to position <b>D</b> (▷ page 140).
	ESP® is switched off.	▶ Switch on ESP® (▷ page 64).
	The system is overheated.	▶ Wait until the system cools down.
Cruise Control and Speedtronic Inoperative	Cruise control is malfunctioning. In addition a warning chime sounds.	▶ Have the cruise control checked at an authorized Mercedes-Benz Center.
Check, Tire Pressure Then Restart Run Flat Indicator (Canada only)	There was a warning message about a loss in tire inflation pressure and the Run Flat Indicator has not been restarted yet.	▶ Make sure the correct tire inflation pressure is set for each tire (▷ page 339). ▶ Then restart the Run Flat Indicator (▷ page 343).
Run Flat Indicator Inoperative (Canada only)	Run Flat Indicator is malfunctioning.	▶ Have the Run Flat Indicator checked at an authorized Mercedes-Benz Center.

Display	Possible cause/consequence	Possible solution
Check Tire Pressure Soon (Canada only)	The Run Flat Indicator indicates that the pressure is too low in one or more tires.	<ul style="list-style-type: none"> <li>▶ Carefully bring the vehicle to a halt, avoiding abrupt steering and braking maneuvers. Observe the traffic situation around you.</li> <li>▶ Check and adjust the tire inflation pressure as required (▷ page 339).</li> <li>▶ If necessary, change the wheel (▷ page 440).</li> <li>▶ Restart the Run Flat Indicator after adjusting the tire inflation pressure values (▷ page 343).</li> </ul>

**Warning!**





Do not drive with a flat tire. A flat tire affects the ability to steer or brake the vehicle. You may lose control of the vehicle. Continued driving with a flat tire will cause excessive heat build-up and possibly a fire.





### What to do if ...?

Display	Possible cause/consequence	Possible solution
Shift to P	<p>You have turned off the engine with the KEYLESS-GO* start/stop button (Canada only) in gear selector lever position <b>N</b> and opened the driver's door.</p> <p>or</p> <p>You have attempted to switch off the engine with the KEYLESS-GO* start/stop button (Canada only) while the gear selector lever was in position <b>R</b> or <b>D</b>.</p>	<ul style="list-style-type: none"> <li>▶ Place the gear selector lever in position <b>P</b>.</li> </ul>
Shift to P or N To Start Engine	You have attempted to start the engine while the automatic transmission* was set to position <b>R</b> or <b>D</b> .	<ul style="list-style-type: none"> <li>▶ Move the gear selector lever to position <b>P</b> or <b>N</b> (▷ page 140).</li> </ul>
Tire Press. Monitor Inoperative (USA only)	The TPMS is malfunctioning.	<ul style="list-style-type: none"> <li>▶ Have the TPMS checked at an authorized Mercedes-Benz Center.</li> </ul>
Wheel Sensors Error Tire Pressure Monitor Inoperative (USA only)	There are wheels without appropriate wheel sensors mounted (e.g. winter tires).	<ul style="list-style-type: none"> <li>▶ Have the TPMS checked at an authorized Mercedes-Benz Center.</li> <li>▶ Have the wheel sensors installed at an authorized Mercedes-Benz Center.</li> </ul>
Tire Press. Monitor Currently Unavailable (USA only)	The TPMS is unable to monitor the tire pressure due to a nearby radio interference source.	<ul style="list-style-type: none"> <li>▶ As soon as the causes of the malfunction have been removed, the TPMS automatically becomes active again after a few minutes driving.</li> </ul>

Display	Possible cause/consequence	Possible solution
<p>Front Passenger Airbag Disabled See Operator's Manual</p>	<p>Front passenger front air bag is deactivated while driving even though an adult or someone larger than a small individual is occupying the front passenger seat. Forces acting on the seat may make the system sense a decrease in weight.</p>	<p>Stop the vehicle in a safe location as soon as possible and check the front passenger seat for the following:</p> <ul style="list-style-type: none"> <li>▶ Switch off the ignition (▷ page 82).</li> <li>▶ Have the front passenger vacate the seat and exit the vehicle.</li> <li>▶ Keep the seat unoccupied, close the front passenger door and switch on the ignition (▷ page 82).</li> </ul> <p>Monitor the   indicator lamp right of the instrument cluster (▷ page 45) and the multifunction display in the instrument cluster (▷ page 151) for the following:</p> <p>(Continued on next page)</p>

## What to do if ...?

Display	Possible cause/consequence	Possible solution
Front Passenger Airbag Disabled See Operator's Manual		<p>With the seat unoccupied and the ignition switched on (▷ page 82),</p> <ul style="list-style-type: none"> <li>the  <b>PASS AIR BAG OFF</b> indicator lamp right of the instrument cluster should illuminate and remain illuminated, indicating that the OCS (▷ page 41) has deactivated the air bag.</li> <li>the message <b>Front Passenger Airbag Enabled See Operator's Manual</b> or the message <b>Front Passenger Airbag Disabled See Operator's Manual</b> should not appear in the multifunction display at any time the seat is unoccupied. Wait at least 60 seconds for the system to complete the necessary check cycles and to make sure neither message appears in the multifunction display.</li> </ul> <p>If above conditions are met, you can occupy the front passenger seat again. Depending on the front passenger classification sensed by the OCS (▷ page 41), the  <b>PASS AIR BAG OFF</b> indicator lamp will remain illuminated or go out.</p> <p>If above conditions are not met, the system is not working properly. Have the system checked as soon as possible at an authorized Mercedes-Benz Center.</p>

### Warning!







If the  **PASS AIR BAG OFF** indicator lamp remains illuminated with an adult occupant on the

front passenger seat even after performing the above corrective steps, do not have any passenger use the front passenger seat until the system has been repaired.



Display	Possible cause/consequence	Possible solution
<p>Front Passenger Airbag Enabled See Operator's Manual</p>	<p>Front passenger front air bag is activated while driving even though a child, small individual, or object below the system's weight threshold is on the front passenger seat, or the front passenger seat is empty. Objects on the seat or forces acting on the seat may make the system sense supplemental weight.</p>	<p>Stop the vehicle in a safe location as soon as possible and check the front passenger seat for the following:</p> <ul style="list-style-type: none"> <li>▶ Switch off the ignition (▷ page 82).</li> <li>▶ Remove child and child restraint from front passenger seat and properly secure the child in rear seat employing the child restraint if necessary.</li> <li>▶ Make sure no objects which apply forces to the seat are present (e.g. objects such as books, briefcases etc. lodged behind or around the seat, head restraints pushing against roof, etc.). The system may recognize such forces as supplemental weight and sense that an occupant on the front passenger seat is of a greater weight than actually present.</li> <li>▶ Keep the seat unoccupied, close the front passenger door and switch on the ignition (▷ page 82).</li> </ul> <p>Monitor the  indicator lamp right of the instrument cluster (▷ page 45) and the multifunction display in the instrument cluster (▷ page 151) for the following: (Continued on next page)</p>

## What to do if ...?

Display	Possible cause/consequence	Possible solution
<p>Front Passenger Airbag Enabled See Operator's Manual</p>		<p>With the seat unoccupied and the ignition switched on (▷ page 82),</p> <ul style="list-style-type: none"> <li>the   indicator lamp right of the instrument cluster should illuminate and remain illuminated, indicating that the OCS (▷ page 41) has deactivated the air bag.</li> <li>the message <b>Front Passenger Airbag Enabled See Operator's Manual</b> or the message <b>Front Passenger Airbag Disabled See Operator's Manual</b> should not appear in the multifunction display at any time the seat is unoccupied. Wait at least 60 seconds for the system to complete the necessary check cycles and to make sure neither message appears in the multifunction display.</li> </ul> <p>If above conditions are met, you can occupy the front passenger seat again. Depending on the front passenger classification sensed by the OCS (▷ page 41), the   indicator lamp will remain illuminated or go out.</p> <p>If above conditions are not met, the system is not working properly. Have the system checked as soon as possible at an authorized Mercedes-Benz Center.</p>

### Warning!



If the   indicator lamp remains illuminated with an adult occupant on the



front passenger seat even after performing the above corrective steps, do not have any passenger use the front passenger seat until the system has been repaired.

Symbol messages

Display	Possible cause/consequence	Possible solution
 <p>ABS and ESP Currently Unavailable See Operator's Manual</p>	<p>ABS and ESP® are not available due to a malfunction. BAS and the hill start assist are also switched off. It is possible that the self-diagnostics have not yet been completed.</p> <p>The brake system still functions normally.</p> <p>The ABS and ESP® were deactivated because of insufficient power supply. The charging voltage has fallen below 10 volts. BAS and the hill start assist are also deactivated.</p> <p>The brake system still functions normally but without the ABS and ESP® available.</p>	<p>► Drive a short distance with gentle turns above a speed of 12 mph (20 km/h).</p> <p>The message disappears when ABS and ESP® are again available.</p> <p>When the voltage is above this value again, the ABS and ESP® are operational again and the message in the multifunction display should disappear.</p> <p>If the message in the multifunction display does not disappear:</p> <p>► Have the generator (alternator) and the battery checked.</p>

### What to do if ...?

Display	Possible cause/consequence	Possible solution
 ABS and ESP Inoperative See Operator's Manual	<p>ABS and ESP<sup>®</sup> are switched off due to a malfunction. BAS and the hill start assist are also switched off.</p> <p>The brake system is still functioning normally but without the ABS available.</p>	<ul style="list-style-type: none"><li>▶ Continue driving with added caution. Wheels may lock during hard braking, reducing steering capability.</li><li>▶ Have the system checked at an authorized Mercedes-Benz Center as soon as possible.</li></ul> <p>Failure to follow these instructions increases the risk of an accident.</p>

Display	Possible cause/consequence	Possible solution
	<p>The battery is no longer charging. Possible causes:</p> <ul style="list-style-type: none"> <li>• alternator malfunctioning</li> <li>• broken poly-V-belt</li> </ul>	<p>▶ Stop the vehicle immediately in a safe location and check the poly-V-belt.</p> <p>If it is broken:</p> <ul style="list-style-type: none"> <li>▶ Do not continue to drive. Otherwise the engine will overheat due to an inoperative water pump which may result in damage to the engine.</li> <li>▶ Notify an authorized Mercedes-Benz Center.</li> </ul> <p>If it is intact:</p> <ul style="list-style-type: none"> <li>▶ Drive immediately to the nearest authorized Mercedes-Benz Center.</li> </ul>
 <p>Check Brake Pad Wear</p>	<p>There is a malfunction in the electronic system.</p> <p>The brake pads have reached their wear limit.</p>	<ul style="list-style-type: none"> <li>▶ Have the system checked at an authorized Mercedes-Benz Center as soon as possible.</li> <li>▶ Have the brake pads replaced as soon as possible.</li> </ul>

**!** Brake pad thickness must be visually checked by a qualified technician at the intervals specified in the Maintenance Booklet.



### What to do if ...?

Display	Possible cause/consequence	Possible solution
<b> BRAKE </b> (USA only) <b> ⓘ </b> (Canada only)	Check Brake Fluid Level	There is insufficient brake fluid in the reservoir.
		Risk of accident! <ul style="list-style-type: none"><li>▶ Carefully stop the vehicle in a safe location or as soon as it is safe to do so.</li><li>▶ Depress the parking brake (▷ page 134).</li><li>▶ Contact an authorized Mercedes-Benz Center.</li><li>▶ Do not add brake fluid! This will not solve the problem.</li></ul>

#### Warning!



Driving with the message **Check Brake Fluid Level** displayed can result in an accident. Have your brake system checked immediately. Do not add brake fluid before checking the brake system. Overfilling the brake fluid reservoir can result in spilling brake fluid on hot engine parts and the brake fluid catching fire. You can be seriously burned.

**!** *If you find that the brake fluid in the brake fluid reservoir has fallen to the minimum mark or below, have the brake system checked for brake pad thickness and leaks.*

Display	Possible cause/consequence	Possible solution
<p><b>BRAKE</b> Release (USA only) Parking Brake <b>(P)</b> (Canada only)</p>	<p>You are driving with the parking brake set.</p>	<p>► Release the parking brake (▷ page 130).</p>
<p><b>BRAKE</b> EBR, ABS, and ESP (USA only) Inoperative <b>(!)</b> See Operator's Manual (Canada only)</p>	<p>EBP, ABS and ESP® are switched off due to a malfunction. BAS and the hill start assist are also switched off.</p> <p>The brake system still functions normally but without the ABS and ESP® available.</p>	<p>► Continue driving with added caution. Wheels may lock during hard braking, reducing steering capability.</p> <p>► Have the system checked at an authorized Mercedes-Benz Center as soon as possible.</p> <p>Failure to follow these instructions increases the risk of an accident.</p>

### What to do if ...?

Display	Possible cause/consequence	Possible solution
 Coolant Low Stop Vehicle! Turn Engine Off	The coolant is too hot.	<ul style="list-style-type: none"><li>▶ Stop the vehicle in a safe location or as soon as it is safe to do so and immediately turn off the engine.</li><li>▶ Only start the engine again after the message disappears. You could otherwise damage the engine.</li><li>▶ Observe the coolant temperature gauge in the instrument cluster (▷ page 26).</li></ul>

#### Warning!



- Driving when your engine is overheated can cause some fluids which may have leaked into the engine compartment to catch fire. You could be seriously burned.
- Steam from an overheated engine can cause serious burns which can occur just by opening the engine hood. Stay away from the engine if you see or hear steam coming from it.



Stop the vehicle in a safe location away from other traffic. Turn off the engine, get out of the vehicle and do not stand near the vehicle until the engine has cooled down.

During severe operating conditions, e.g. stop-and-go traffic, the coolant temperature may rise close to 248°F (120°C).

**!** *The engine should not be operated with the coolant temperature above 248°F (120°C). Doing so may cause serious engine damage which is not covered by the Mercedes-Benz Limited Warranty.*

Display	Possible cause/consequence	Possible solution
 <p>Coolant Low Stop Vehicle! Turn Engine Off</p>	<p>The poly-V-belt could be broken.</p>	<ul style="list-style-type: none"> <li>▶ Stop the vehicle in a safe location or as soon as it is safe to do so and immediately turn off the engine.</li> <li>▶ Check the poly-V-belt.</li> </ul> <p>If it is broken:</p> <ul style="list-style-type: none"> <li>▶ Do not continue to drive. Otherwise the engine will overheat due to an inoperative water pump which may result in damage to the engine.</li> <li>▶ Notify an authorized Mercedes-Benz Center.</li> </ul> <p>If it is intact:</p> <ul style="list-style-type: none"> <li>▶ Do not continue to drive the vehicle with this message displayed. Doing so could result in serious engine damage that is not covered by the Mercedes-Benz Limited Warranty.</li> <li>▶ Observe the coolant temperature gauge in the instrument cluster (&gt; page 26).</li> </ul> <p>(Continued on next page)</p>

### What to do if ...?

Display	Possible cause/consequence	Possible solution
 Coolant Low Stop Vehicle! Turn Engine Off		<ul style="list-style-type: none"><li>▶ Restart the engine.</li></ul> <p>If this message disappears from the multifunction display:</p> <ul style="list-style-type: none"><li>▶ Drive immediately to the nearest authorized Mercedes-Benz Center.</li></ul> <p>If this message does not disappear from the multifunction display:</p> <ul style="list-style-type: none"><li>▶ Call Roadside Assistance.</li></ul>
	The cooling fan for the coolant is malfunctioning.	<ul style="list-style-type: none"><li>▶ Observe the coolant temperature gauge in the instrument cluster (&gt; page 26).</li><li>▶ Have the fan replaced as soon as possible.</li></ul>

Display	Possible cause/consequence	Possible solution
 <p>Check Coolant Level See Operator's Manual</p>	The coolant level is too low.	<ul style="list-style-type: none"> <li>▶ Add coolant (▷ page 329).</li> <li>▶ If you have to add coolant frequently, have the cooling system checked at an authorized Mercedes-Benz Center.</li> </ul>

**Warning!**







Do not spill antifreeze on hot engine parts. Antifreeze contains ethylene glycol which may burn if it comes into contact with hot engine parts. You could be seriously burned.

**!** Do not ignore the low engine coolant level warning. Extended driving with the message and symbol displayed may cause serious engine damage not covered by the Mercedes-Benz Limited Warranty.

*Do not drive without a sufficient amount of coolant in the cooling system. The engine will overheat, causing major engine damage.*



### What to do if ...?



Display	Possible cause/consequence	Possible solution
	<p>You are driving with one or more doors open.</p> <p>The display symbol shows you which doors are open.</p>	<ul style="list-style-type: none"> <li>▶ Close the doors.</li> </ul>
 Gas Cap Loose	<p>A loss of pressure has been detected in the fuel system. The fuel cap may not be closed properly or the fuel system may be leaky.</p>	<ul style="list-style-type: none"> <li>▶ Check the fuel cap (▷ page 322).</li> </ul> <p>If it is not closed properly:</p> <ul style="list-style-type: none"> <li>▶ Close the fuel cap.</li> </ul> <p>If it is closed properly:</p> <ul style="list-style-type: none"> <li>▶ Have the fuel system checked at an authorized Mercedes-Benz Center.</li> </ul>
Reserve Fuel Level	<p>The fuel level has gone below the reserve mark.</p>	<p>Refuel at the next gas station (▷ page 322).</p>
	<p>You are driving with the hood open.</p>	<ul style="list-style-type: none"> <li>▶ Stop your vehicle as soon as it is safe to do so.</li> <li>▶ Close the hood (▷ page 326).</li> </ul> <p>There is otherwise danger of an accident.</p>

Display	Possible cause/consequence	Possible solution
 <p>Key Not Detected</p>	<p>The SmartKey with KEYLESS-GO* (Canada only) is not recognized while the engine is running because the SmartKey with KEYLESS-GO* (Canada only) is not in the vehicle.</p> <p>The SmartKey with KEYLESS-GO* (Canada only) is not recognized while the engine is running because there is strong radio-frequency interference.</p>	<ul style="list-style-type: none"> <li>▶ Stop the vehicle in a safe location or as soon as it is safe to do.</li> <li>▶ Search for the SmartKey.</li> </ul> <p>Otherwise the vehicle cannot be centrally locked nor can the engine be started again after the engine is stopped.</p> <ul style="list-style-type: none"> <li>▶ Stop the vehicle in a safe location or as soon as it is safe to do.</li> <li>▶ Remove KEYLESS-GO* button (Canada only) from the starter switch (▷ page 83).</li> <li>▶ Operate the vehicle with the SmartKey in the starter switch.</li> </ul>
 <p>Key Not Detected</p>	<p>The SmartKey with KEYLESS-GO* (Canada only) is momentarily not recognized.</p>	<ul style="list-style-type: none"> <li>▶ Change the position of the SmartKey in the vehicle.</li> <li>▶ If necessary, operate vehicle using SmartKey with KEYLESS-GO* (Canada only) in starter switch under KEYLESS-GO* button (Canada only) (▷ page 83).</li> </ul>





### What to do if ...?

Display	Possible cause/consequence	Possible solution
 <p>Replace Key Battery</p> <p>Key Detected In Vehicle</p> <p>Obtain A New Key</p> <p>Remove "Start" Button And Insert Key</p>	The batteries in the SmartKey with KEYLESS-GO* are discharged.	▶ Replace the batteries (▷ page 428).
	A SmartKey with KEYLESS-GO* (Canada only) left in the vehicle was recognized while locking the vehicle from the outside.	▶ Take the SmartKey with KEYLESS-GO* out of the vehicle.
	The SmartKey with KEYLESS-GO* (Canada only) must be replaced.	▶ Contact an authorized Mercedes-Benz Center as soon as possible.
	The KEYLESS-GO* system (Canada only) is malfunctioning.	<p>▶ Remove KEYLESS-GO* button (Canada only) from the starter switch (▷ page 83).</p> <p>▶ Operate the vehicle with the SmartKey in the starter switch.</p>
 <p>Close Doors To Lock Vehicle</p> <p>Key Does Not Belong to Vehicle</p> <p>Don't Forget Your Key</p>	You wanted to lock the vehicle but not all doors were closed.	▶ Close doors and lock vehicle again.
	You have insert an incorrect key in the starter switch.	▶ Remove key and insert the correct key.
	This display appears (for a maximum of 60 seconds) if the driver's door is opened with the engine turned off and no SmartKey in the starter switch. This message is only a reminder.	▶ Take the SmartKey or SmartKey with KEYLESS-GO* (Canada only) with you when leaving the vehicle.

Display	Possible cause/consequence	Possible solution
 Take Your Key From Ignition	You have forgotten to remove the SmartKey.	<ul style="list-style-type: none"> <li>▶ Remove the SmartKey from the starter switch.</li> </ul>
 AUTO Lamp Function Inoperative	The light sensor is malfunctioning. Daytime driving lamps are switched on.	<ul style="list-style-type: none"> <li>▶ In the instrument cluster control system, set lamp operation to manual mode.</li> <li>▶ Switch on headlamps using the exterior lamp switch.</li> <li>▶ Contact an authorized Mercedes-Benz Center as soon as possible.</li> </ul>
Check Center Brake Lamp	The high mounted brake lamp is malfunctioning. This message will only appear if all light emitting diodes have stopped working.	<ul style="list-style-type: none"> <li>▶ Contact an authorized Mercedes-Benz Center as soon as possible.</li> </ul>
Check Left Brake Lamp	The left brake lamp is malfunctioning.	<ul style="list-style-type: none"> <li>▶ Replace the bulb as soon as possible (▷ page 436).</li> </ul>
Check Right Brake Lamp	The right brake lamp is malfunctioning.	<ul style="list-style-type: none"> <li>▶ Replace the bulb as soon as possible (▷ page 436).</li> </ul>

### What to do if ...?

Display	Possible cause/consequence	Possible solution
 Check Left Cornering Light	The left-hand corner-illuminating lamp is malfunctioning.	▶ Contact an authorized Mercedes-Benz Center as soon as possible.
Check Right Cornering Light	The right-hand corner-illuminating lamp is malfunctioning.	▶ Contact an authorized Mercedes-Benz Center as soon as possible.
Check Left Fog Lamp	The left front fog lamp is malfunctioning.	▶ Contact an authorized Mercedes-Benz Center as soon as possible.
Check Right Fog Lamp	The right front fog lamp is malfunctioning.	▶ Contact an authorized Mercedes-Benz Center as soon as possible.
Check Rear Left Fog Lamp	The left rear fog lamp is malfunctioning.	▶ Contact an authorized Mercedes-Benz Center as soon as possible.
Check Left High Beam	The left high beam lamp is malfunctioning.	▶ Replace the bulb as soon as possible (▷ page 433).
Check Right High Beam	The right high beam lamp is malfunctioning.	▶ Replace the bulb as soon as possible (▷ page 433).

Display	Possible cause/consequence	Possible solution
 Check Left License Plate Lamp	The left license plate lamp is malfunctioning.	► Contact an authorized Mercedes-Benz Center as soon as possible.
Check Right License Plate Lamp	The right license plate lamp is malfunctioning.	► Contact an authorized Mercedes-Benz Center as soon as possible.
Check Left Low Beam	The left low beam lamp is malfunctioning.	► Contact an authorized Mercedes-Benz Center as soon as possible.
Check Right Low Beam	The right low beam lamp is malfunctioning.	► Contact an authorized Mercedes-Benz Center as soon as possible.
Check Front Left Parking Lamp	The left front parking lamp is malfunctioning.	► Contact an authorized Mercedes-Benz Center as soon as possible.
Check Front Right Parking Lamp	The right front parking lamp is malfunctioning.	► Contact an authorized Mercedes-Benz Center as soon as possible.
Check Left Reverse Lamp	The left reverse lamp is malfunctioning.	► Contact an authorized Mercedes-Benz Center as soon as possible.
Check Right Reverse Lamp	The right reverse lamp is malfunctioning.	► Contact an authorized Mercedes-Benz Center as soon as possible.

### What to do if ...?

Display	Possible cause/consequence	Possible solution
 Check Front Left Side Marker Lamp	The front left side marker lamp is malfunctioning.	► Contact an authorized Mercedes-Benz Center as soon as possible.
Check Front Right Side Marker Lamp	The front right side marker lamp is malfunctioning.	► Contact an authorized Mercedes-Benz Center as soon as possible.
Check Rear Left Side Marker Lamp	The rear left side marker lamp is malfunctioning.	► Contact an authorized Mercedes-Benz Center as soon as possible.
Check Rear Right Side Marker Lamp	The rear right side marker lamp is malfunctioning.	► Contact an authorized Mercedes-Benz Center as soon as possible.
Check Left Tail and Brake Lamps	The left tail lamp/brake lamp is malfunctioning.	► Contact an authorized Mercedes-Benz Center as soon as possible.
Check Right Tail and Brake Lamps	The right tail lamp/brake lamp is malfunctioning.	► Contact an authorized Mercedes-Benz Center as soon as possible.

Display	Possible cause/consequence	Possible solution
 Check Left Tail Lamp	The left tail lamp is malfunctioning.	► Contact an authorized Mercedes-Benz Center as soon as possible.
Check Right Tail Lamp	The right tail lamp is malfunctioning.	► Contact an authorized Mercedes-Benz Center as soon as possible.
Check Front Left Turn Signal	The left front turn signal lamp is malfunctioning.	► Contact an authorized Mercedes-Benz Center as soon as possible.
Check Front Right Turn Signal	The right front turn signal lamp is malfunctioning.	► Contact an authorized Mercedes-Benz Center as soon as possible.
Check Rear Left Turn Signal	The left rear turn signal lamp is malfunctioning.	► Contact an authorized Mercedes-Benz Center as soon as possible.
Check Rear Right Turn Signal	The right rear turn signal lamp is malfunctioning.	► Contact an authorized Mercedes-Benz Center as soon as possible.

### What to do if ...?

Display	Possible cause/consequence	Possible solution
 Check Left Mirror Turn Signal	The turn signal in the left exterior rear view mirror is malfunctioning. This message will only appear if all light emitting diodes have stopped working.	▶ Have the LEDs replaced as soon as possible.
 Check Right Mirror Turn Signal	The turn signal in the right exterior rear view mirror is malfunctioning. This message will only appear if all light emitting diodes have stopped working.	▶ Have the LEDs replaced as soon as possible.
Switch Off Lights	You are getting out of the vehicle and the lights are still switched on.	▶ Switch off the headlamps (▷ page 108).
Turn Lights Off Or Remove Key	The exterior lamp switch is set to <b>A</b> and you have forgotten to take out the SmartKey. The parking lamps remain switched on.	▶ Switch off the headlamps (▷ page 108). or ▶ Remove the SmartKey from the starter switch.

Display	Possible cause/consequence	Possible solution
 <p>Check Engine Oil At Next Refueling</p>	<p>The engine oil level has dropped to approximately the minimum level.</p>	<ul style="list-style-type: none"> <li>▶ Check the engine oil level (▷ page 327) and add engine oil as required (▷ page 328).</li> <li>▶ If you must add engine oil frequently, have the engine checked for possible leaks.</li> </ul>

When the message **Check Engine Oil At Next Refueling** appears while the engine is running and at operating temperature, the engine oil level has dropped to approximately the minimum level.

**!** *The engine oil level warnings should not be ignored. Extended driving with the symbol displayed could result in serious engine damage that is not covered by the Mercedes-Benz Limited Warranty.*

When this occurs, the warning will first come on intermittently and then stay on if the oil level drops further.

Visually check for oil leaks. If no obvious oil leaks are noted, continue to drive to the nearest service station where the engine oil should be topped to the required level with an approved oil specified in the Factory Approved Service Products pamphlet.

For information on approved engine oils, refer to the Factory Approved Service Products pamphlet (USA only) or contact an authorized Mercedes-Benz Center.



### What to do if ...?

Display	Possible cause/consequence	Possible solution
 SRS Malfunction Service Required	There is a malfunction in the supplemental restraint systems. The air bags or emergency tensioning devices (ETDs) could deploy unexpectedly or fail to activate in an accident.	▶ Drive with added caution to the nearest authorized Mercedes-Benz Center.
Front Left SRS Malfunction Service Required	Components of the driver's supplemental restraint system may not work properly.	▶ Drive with added caution to the nearest authorized Mercedes-Benz Center.
Front Right SRS Malfunction Service Required	Components of the front passenger's supplemental restraint system may not work properly.	▶ Drive with added caution to the nearest authorized Mercedes-Benz Center.
Rear Left SRS Malfunction Service Required	Components of the left rear passenger's supplemental restraint system may not work properly.	▶ Drive with added caution to the nearest authorized Mercedes-Benz Center.

### Warning!



In the event that a malfunction of the SRS is indicated as outlined above, the SRS may not be operational. For your safety, we strongly recommend that you contact an authorized Mercedes-Benz Center

immediately to have the system checked; otherwise the SRS may not be deployed when needed in an accident, which could result in serious or fatal injury, or it might deploy unexpectedly and unnecessarily which could result in an accident and/or injury to you or to others.

Display	Possible cause/consequence	Possible solution
 Rear Center SRS Malfunction Service Required	Components of the center rear passenger's supplemental restraint system may not work properly.	► Drive with added caution to the nearest authorized Mercedes-Benz Center.
Rear Right SRS Malfunction Service Required	Components of the right rear passenger's supplemental restraint system may not work properly.	► Drive with added caution to the nearest authorized Mercedes-Benz Center.
Left Side Curtain Airbag Malfunction Service Required	The left side window curtain air bag may not work properly.	► Drive with added caution to the nearest authorized Mercedes-Benz Center.
Right Side Curtain Airbag Malfunction Service Required	The right side window curtain air bag may not work properly.	► Drive with added caution to the nearest authorized Mercedes-Benz Center.



**Warning!**



In the event that a malfunction of the SRS is indicated as outlined above, the SRS may not be operational. For your safety, we strongly recommend that you contact an authorized Mercedes-Benz Center

immediately to have the system checked; otherwise the SRS may not be deployed when needed in an accident, which could result in serious or fatal injury, or it might deploy unexpectedly and unnecessarily which could result in an accident and/or injury to you or to others.

### What to do if ...?



Display	Possible cause/consequence	Possible solution
 Tele Aid Inoperative	One or more main functions of the Tele Aid* system are malfunctioning.	▶ Have the Tele Aid* system checked at an authorized Mercedes-Benz Center.
 Correct Tire Pressure (USA only)	The tire pressure is too low in one or more tires.	▶ Check and correct tire inflation pressure as required (▷ page 339).
Tire Press. Warning Caution Tire Malfunction (USA only)	One or more tires are deflating.	▶ Carefully bring the vehicle to a halt, avoiding abrupt steering and braking maneuvers. ▶ If necessary, change the wheel (▷ page 440).
Check Tire Pressure (USA only)	The tire pressure in one or more tires is already below the minimum value.	▶ Carefully bring the vehicle to a halt, avoiding abrupt steering and braking maneuvers. ▶ Check and adjust tire pressure as required (▷ page 339). ▶ If necessary, change the wheel (▷ page 440).

### Warning!



Do not drive with a flat tire. A flat tire affects the ability to steer or brake the vehicle. You

may lose control of the vehicle. Continued driving with a flat tire will cause excessive heat build-up and possibly a fire.

Display	Possible cause/consequence	Possible solution
	You are driving with the trunk open.	▶ Close the trunk (▷ page 270).
 <p data-bbox="263 273 414 329">Check Washer Fluid</p>	The water level has dropped to approx. 1.1 US qts (1.0 l).	▶ Add washer fluid (▷ page 330).

### Where will I find ...?

#### First aid kit

---

**i** Check expiration dates and contents for completeness at least once a year and replace missing/expired items.

Depending on the equipment configuration, the first-aid kit will be located either in the open storage department in the trunk or behind the cover panel on the left-hand side of the trunk.

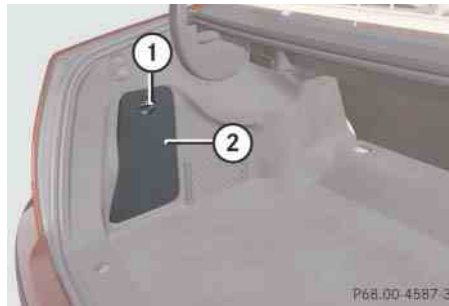

① Rotary handle

② Cover

- ▶ **Opening:** Turn the handle ① counter-clockwise.
- ▶ Fold the cover ② downward.
- ▶ Remove the first aid kit.

#### Vehicle jack, vehicle tool kit, luggage bowl, Minispare wheel

---

The vehicle jack, Minispare wheel, vehicle tool kit, and the luggage bowl are stored in the compartment underneath the trunk floor.

#### Vehicle tool kit

The vehicle tool kit includes:

- One towing eye bolt
- One wheel wrench
- Collapsible wheel chock
- One pair of gloves

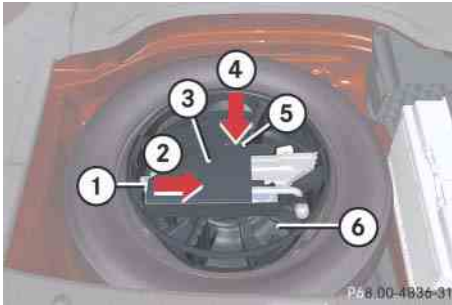

- ① Tab
- ② Removing
- ③ Vehicle tool kit, jack and collapsible wheel chock
- ④ Opening
- ⑤ Tab
- ⑥ Luggage bowl

- ▶ **Removing:** Lift up trunk floor cover and engage trunk floor handle in upper edge of trunk.
- ▶ Pull tab ① in direction of arrow ② and lift up vehicle tool kit ③.

You can now remove the vehicle tool kit ③ from luggage bowl ⑥.

- ▶ **Opening:** Pull tab ⑤ in direction of arrow ④ and open the vehicle tool kit cover.

You can now remove the tools and accessories from vehicle tool kit ③.

- ▶ **Closing:** Store the tools and accessories in vehicle tool kit ③.
- ▶ Press the vehicle tool kit cover down until it engage.
- ▶ **Installing:** Slide the vehicle tool kit ③ into the recess in luggage bowl ⑥.
- ▶ Press vehicle tool kit ③ down until tab ① engage in luggage bowl ⑥.
- ▶ Disengage trunk floor handle from upper edge of trunk and lower trunk floor.

**!** *To prevent damage, always disengage trunk floor handle from trunk lid and lower trunk floor before closing the trunk.*

## Vehicle jack

### Warning!



The jack is designed exclusively for jacking up the vehicle at the jack take-up brackets built into both sides of the vehicle. To help avoid personal injury, use the jack only to lift the vehicle during a wheel change. Never get beneath the vehicle while it is supported by the jack. Keep hands and feet away from the area under the lifted vehicle. Always firmly depress the parking brake and block wheels before raising vehicle with jack.

Do not release the parking brake while the vehicle is raised. Be certain that the jack is always vertical (plumb line) when in use, especially on hills. Always try to use the jack on level surface. Make sure the jack arm is fully seated in the jack take-up bracket. Always lower the vehicle onto sufficient capacity jackstands before working under the vehicle.



### Where will I find ...?

▷▷

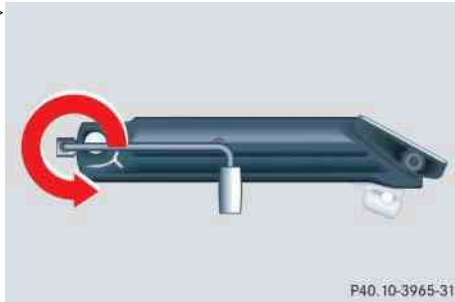

#### Storage position

- ▶ Remove vehicle jack from its compartment.
- ▶ Turn crank handle in direction of arrow as far as it will go.

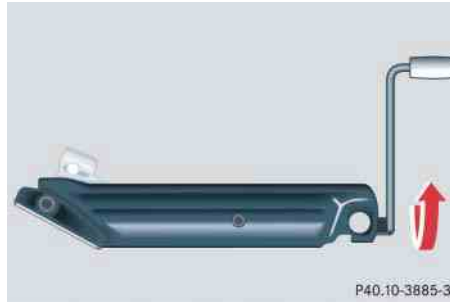

#### Operational position

- ▶ Turn crank handle clockwise.

Before storing the vehicle jack in its compartment:

- It should be fully collapsed.
- The handle must be folded in (storage position).

### Minispare wheel

The Minispare wheel is stored in the compartment underneath the trunk floor.

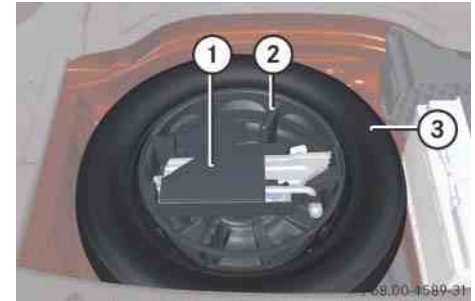

- ① Vehicle tool kit, jack and collapsible wheel chock
- ② Luggage bowl
- ③ Minispare wheel

**Removing the Minispare wheel**

- ▶ Remove vehicle tool kit ① (▷ page 421).
- ▶ Turn luggage bowl ② counterclockwise and remove it.
- ▶ Remove Minispare wheel ③.

**Setting up the collapsible wheel chock**

The collapsible wheel chock serves to additionally secure the vehicle, e.g. while changing the wheel.

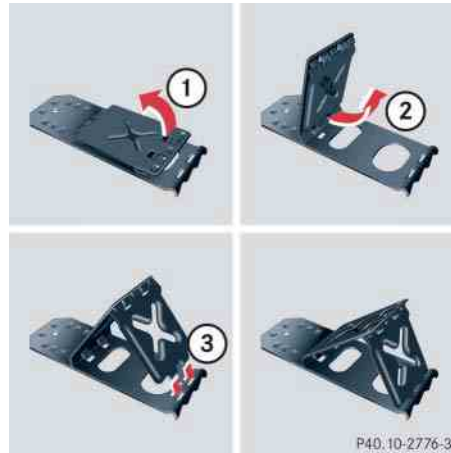

- ① Tilt the plates upward
- ② Fold the lower plate outward
- ③ Insert the plate

- ▶ Tilt both plates upward ①.
- ▶ Fold the lower plate outward ②.
- ▶ Guide the tabs of the lower plate all the way into the openings of the base plate ③.

For information on where to place wheel chocks when changing a wheel, see “Lifting the vehicle” (▷ page 441).



### Unlocking/locking in an emergency

#### Unlocking the vehicle

If you cannot unlock the vehicle with the SmartKey or KEYLESS-GO\* (Canada only), unlock the driver's door and the trunk using the mechanical key.

**i** *Unlocking the vehicle with the mechanical key and opening the driver's door or the trunk with the mechanical key will trigger the anti-theft alarm system (▷ page 66).*

*To cancel the alarm, insert the SmartKey or SmartKey with KEYLESS-GO\* (Canada only) in the starter switch.*

#### Removing the mechanical key

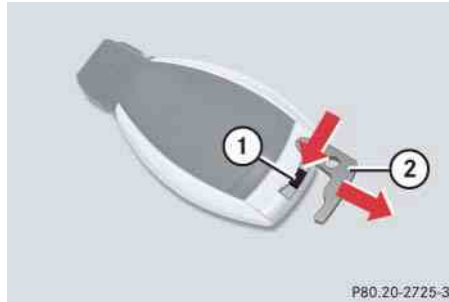

- ① Mechanical key locking tab
- ② Mechanical key

- ▶ Move locking tab ① in the direction of arrow.
- ▶ Slide mechanical key ② out of the housing.

#### Unlocking the driver's door



- 1 Unlocking
- ② Mechanical key

- ▶ Insert mechanical key ② into the driver's door lock until it stops.
- ▶ Turn mechanical key ② counterclockwise to position 1.  
The locking knob moves up, the driver's door is unlocked.
- ▶ Pull the door handle to open the driver's door.

Unlocking/locking in an emergency

Unlocking the trunk

A minimum height clearance of 5.9 ft (1.90 m) is required to open the trunk lid.



P80.20-3043-31

1 Unlocking in an emergency

② Mechanical key

- ▶ Insert the mechanical key ② into the trunk lid lock until it stops.
- ▶ Turn mechanical key ② all the way counterclockwise to position 2.

The trunk opens.

**!** The trunk lid swings open upwards automatically. Always make sure there is sufficient overhead clearance.

- ▶ Turn the mechanical key ② back and remove it from the trunk lid lock.

Locking the vehicle

If you cannot lock the vehicle with the SmartKey or KEYLESS-GO\* (Canada only), do the following:

- ▶ Close the front passenger door, the rear doors and the trunk.
- ▶ Open the driver's door.
- ▶ Press the central locking switch on the driver's door (▷ page 81).

The locking knobs of the front passenger door and the rear doors move down.

If the vehicle battery is disconnected or drained:

- ▶ Press down the locking knobs of the front passenger door and the rear doors manually.
- ▶ Exit the vehicle.
- ▶ Close the driver's door.



P80.20-3097-31

1 Locking

② Mechanical key

- ▶ Use the mechanical key ② to lock the vehicle from the outside via the driver's door. Turn the mechanical key ② to position 1.
- ▶ The locking knob of the driver's door moves down. The vehicle is locked.
- ▶ Check whether the doors and the trunk are locked.
- ▶ If necessary, lock the trunk with the mechanical key ② (▷ page 272).



### Unlocking/locking in an emergency

- ▷▷ **i** This procedure does not arm the anti-theft alarm system nor does it lock the fuel filler flap.

#### Fuel filler flap

- ▶ Open the fuse box in the trunk (▷ page 458).



- ① Release cable
- ▶ Pull on the release cable ①.
- ▶ Open the fuel filler flap.

#### Manually unlocking the transmission gear selector lever

In case of power failure, the transmission gear selector lever can be manually unlocked, e.g. to tow the vehicle.



- ① Selector lever cover
- ② Unlocking mechanism
- ▶ Apply the parking brake firmly.
- ▶ Push the selector lever cover ① to the left and pull it up and off.
- ▶ Push the unlocking mechanism ② down and move the selector lever out of position **P** at the same time.

The selector lever can now move freely until reset to position **P**.

- i** The gear selector lever is locked again when moving it to position **P**.

Resetting activated head restraints

▼ Resetting activated head restraints

If the active head restraints (front seats) have been triggered in an accident, the active head restraints must be reset. Otherwise, the active head restraints cannot offer any additional protection in the event of another rear-end collision.

You can tell that the head restraints have been triggered when they have been moved forward and cannot be adjusted.

**Warning!**



For safety reasons, have the active head restraints checked at an authorized Mercedes-Benz Center after a rear-end collision.

**Warning!**



When pushing back the head restraint cushion, take care that your fingers do not become caught between the head restraint cushion and the cover. Failing to do so may lead to injury.



- ① Fold back
- ② Push back
- ③ Push down

- ▶ Push the head restraint cushion by the bottom, back as far as it will go ②.
- ▶ Push the head restraint cushion down into the guide as far as it will go ③.
- ▶ Fold the head restraint cushion by the top, back firmly until it engages ①.

**i** For your convenience, we recommend that you have this work carried out at an authorized Mercedes-Benz Center.

- ▶ Repeat this procedure on the active head restraints for second head restraint.

For information on active head restraints, see “Active head restraints” (▷ page 50).

For information on head restraint adjustment, see “Adjusting rear head restraints” (▷ page 89).

### Replacing SmartKey batteries

If the batteries in the SmartKey/SmartKey with KEYLESS-GO\* are discharged, the vehicle can no longer be locked or unlocked. It is recommended to have the batteries replaced at an authorized Mercedes-Benz Center.

#### Warning!



Batteries contain poisonous and corrosive substances. Therefore keep the batteries out of reach of children.

If a battery is swallowed, seek medical help immediately.

#### Warning!



SmartKey batteries contain Perchlorate material, which may require special handling and regard for the environment. Check with your local government's disposal guidelines. California residents, see <http://www.dtsc.ca.gov/HazardousWaste/Perchlorate/index.cfm>.

Batteries contain materials that can harm the environment if disposed of improperly. Recycling of batteries is the preferred method of disposal. Many states require sellers of batteries to accept old batteries for recycling.

**i** When replacing batteries, make sure they are clean and free of lint.

**i** When replacing batteries, always replace both batteries. The required replacement batteries are available at any authorized Mercedes-Benz Center.

Replacement batteries: Lithium, type CR 2025 or equivalent.

- ▶ Remove the mechanical key from the SmartKey (▷ page 424).

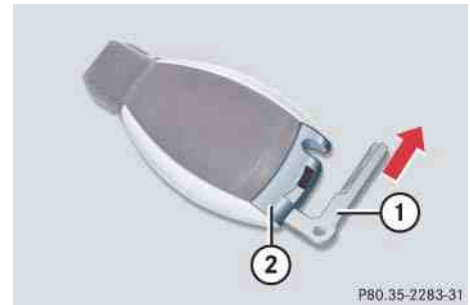

- ① Mechanical key
- ② Battery compartment

- ▶ Insert mechanical key ① into opening.
- ▶ Press mechanical key ① in direction of arrow.  
The battery compartment is unlatched.
- ▶ Pull battery compartment ② out of the housing.

Replacing SmartKey batteries

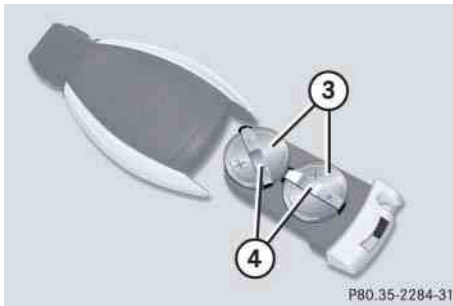

③ Batteries

④ Contact springs

- ▶ Pull out batteries ③.

- ▶ Using a line-free cloth, insert new batteries ③ under contact springs ④ with the positive terminal (+) side facing up.
- ▶ Return battery compartment ② into housing until it locks into place.
- ▶ Slide the mechanical key back into the SmartKey.
- ▶ Check the operation of the SmartKey or SmartKey with KEYLESS-GO\*.

### Replacing bulbs

Safe vehicle operation depends on proper exterior lighting and signaling. It is therefore essential that all bulbs and lamp assemblies are in good working order at all times.

Correct headlamp adjustment is extremely important. Have headlamps checked and readjusted at regular intervals and when a bulb has been replaced. See an authorized Mercedes-Benz Center for headlamp adjustment.

**i** *If the headlamps or front fog lamps are fogged up on the inside as a result of high humidity, driving the vehicle a distance with the lights on should clear up the fogging.*

**i** *Backup bulbs will be brought into use when lamps malfunction. Read and observe the messages in the multifunction display (▷ page 413).*

Bulbs

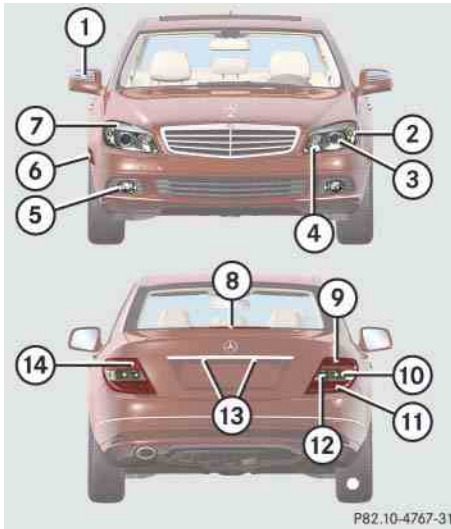

P82.10-4767-31

Front lamps

Lamp	Type
① Additional turn signal lamp	LED
② Turn signal lamp	PY 21 W
③ Halogen headlamp: Low beam	H7 (55 W)
Bi-Xenon* headlamp: Low and high beam <sup>1</sup>	D1S-35 W
④ Halogen headlamp: High beam/high beam flasher	H7 (55 W)
Bi-Xenon* headlamp: High beam flasher	H7 (55 W)
⑤ Front fog lamp	H11 (55 W)
Corner-illuminating front fog lamp*	H11 (55 W)
⑥ Side marker lamp	W 5 W
⑦ Parking and standing lamp	2 x W 5 W-BV

<sup>1</sup> Regarding vehicles with Bi-Xenon headlamps\*, do not replace the Bi-Xenon bulbs yourself.

Rear lamps

Lamp	Type
⑧ High mounted brake lamp	LED
⑨ Side marker	W 5 W
⑩ Turn signal lamp	PY 21 W
⑪ Brake lamp, parking and standing lamp, tail lamp	2 x P 21 W
⑫ Backup lamp	P 21 W
⑬ License plate lamps	W 5 W
⑭ Rear fog lamp (driver's side only), Side marker	P 21 W W 5 W



### Replacing bulbs

#### Warning!



Keep bulbs out of reach of children.

Bulbs and bulb sockets can be very hot. Allow the lamp to cool down before changing a bulb.

Halogen lamps contain pressurized gas. A bulb can explode if you:

- touch or move it when hot
- drop the bulb
- scratch the bulb

Wear eye and hand protection.

Because of high voltage in Xenon lamps, it is dangerous to replace the bulb or repair the lamp and its components. We recommend that you have such work done by a qualified technician.

#### Notes on bulb replacement

- Only use 12 volt bulbs of the same type and with the specified watt rating.
- Switch lights off before changing a bulb to prevent short circuits.
- Always use a clean lint-free cloth when handling bulbs.
- Your hands should be dry and free of oil and grease.
- If the newly installed bulb does not come on, visit an authorized Mercedes-Benz Center.

Have the LEDs and bulbs for the following lamps replaced at an authorized Mercedes-Benz Center.

- Additional turn signal lamps in the exterior rear view mirrors
- High mounted brake lamp
- Bi-Xenon\* lamps
- Front fog lamps
- Front side marker lamps
- License plate lamps

**!** *Do not replace the LEDs yourself. You could otherwise damage the LEDs or parts of the vehicle. Only have the LEDs replaced at an authorized Mercedes-Benz Center.*

#### Replacing bulbs for front lamps

Before you start to replace a bulb for a front lamp, do the following first:

- ▶ Turn the exterior lamp switch to position **0** (▷ page 108).
- ▶ Open the hood (▷ page 325).

Front lamps halogen-type

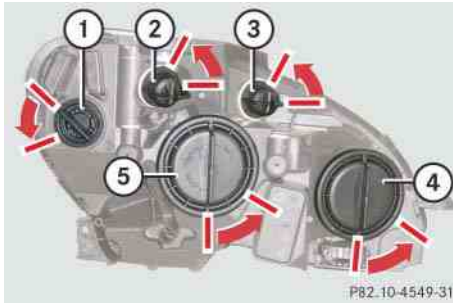

- ① Bulb socket for turn signal lamp bulb
- ② Housing cover for parking and standing lamp
- ③ Housing cover for parking and standing lamp
- ④ Housing cover for high beam headlamp
- ⑤ Housing cover for low beam headlamp

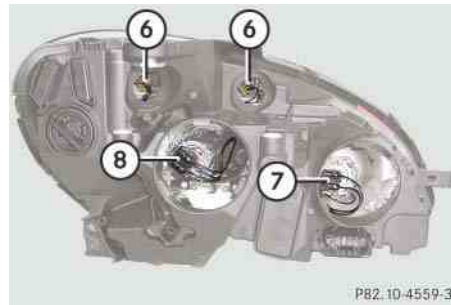

- ⑥ Bulb socket for parking and standing lamp bulb
- ⑦ Bulb holder of high beam bulb
- ⑧ Bulb holder of low beam bulb

**Low beam bulb**

- ▶ Turn housing cover ⑤ counterclockwise and remove it.
- ▶ Pull electric plug off the bulb.
- ▶ Remove wire clip from bulb holder ⑧ by pushing down and release from ar-restor hook.
- ▶ Pull the bulb at its socket out of bulb holder ⑧.

- ▶ Insert the new bulb so that its socket locates in the recess of bulb holder ⑧ and is level to it.
- ▶ Fold wire clip back and press it down on bulb holder ⑧ to engage it in the ar-restor hook.
- ▶ Connect electric plug on the bulb.
- ▶ Align housing cover ⑤ and turn it clockwise.

**High beam bulb**

- ▶ Turn housing cover ④ counterclockwise and remove it.
- ▶ Turn bulb holder ⑦ with the bulb counterclockwise and remove it.
- ▶ Pull the bulb at its socket out of bulb holder ⑦.
- ▶ Insert the new bulb so that its socket locates in the recess of bulb holder ⑦ and is level to it.
- ▶ Reinsert bulb holder ⑦ with the bulb in the lamp and turn clockwise.



### Replacing bulbs

- ▷▷▶ Align housing cover ④ and turn it clockwise.

#### Front turn signal lamp bulb

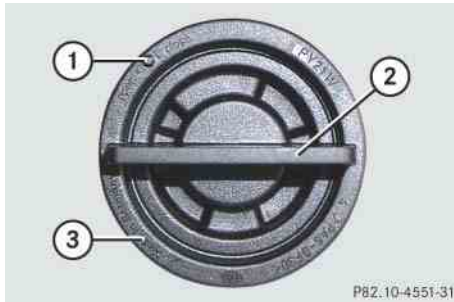

- ① Mark
  - ② Handle
  - ③ Bulb socket
- ▶ Turn bulb socket ③ with handle ② counterclockwise and remove it.
- ▶ Press gently onto the bulb and turn counterclockwise out of bulb socket ③.
- ▶ Press the new bulb gently into bulb socket ③ and turn clockwise until it engages.

- ▶ Place bulb socket ③ back into the lamp. Handle ② must be in a horizontal line and mark ① is on the upper part.
- ▶ Turn bulb socket ③ clockwise until it engages.

#### Parking and standing lamp bulb

- ▶ Turn housing cover ② or ③ counterclockwise and remove it.
- ▶ Pull out bulb socket ⑥ with the bulb.
- ▶ Pull the bulb out of the bulb socket ⑥.
- ▶ Press the new bulb into bulb socket ⑥.
- ▶ Press bulb socket ⑥ back into the lamp.
- ▶ Align housing cover ② or ③ and turn it clockwise.

#### Front lamps Bi-Xenon\*-type

##### Warning!



Do not remove the cover ⑤ for the Bi-Xenon\* headlamp. Because of high voltage in Xenon lamps, it is dangerous to replace the bulb or repair the lamp and its components. We recommend that you have such work done by a qualified technician.

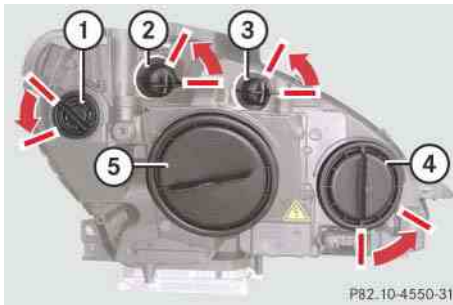

- ① Bulb socket for turn signal lamp bulb
- ② Housing cover for parking and standing lamp
- ③ Housing cover for parking and standing lamp
- ④ Housing cover for high beam flasher
- ⑤ Housing cover for Bi-Xenon headlamp

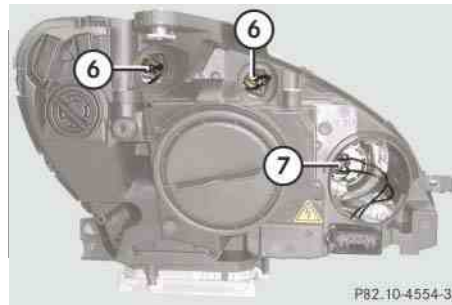

- ⑥ Bulb socket for parking and standing lamp bulb
- ⑦ Bulb holder for high beam flasher bulb



- ⑦ Bulb holder for high beam bulb

**High beam bulb for high beam flasher**

- ▶ Turn housing cover ④ counterclockwise and remove it.
- ▶ Pull electric plug off the bulb.
- ▶ Pull out bulb holder ⑦ with the bulb.
- ▶ Pull the bulb at its socket out of bulb holder ⑦.
- ▶ Insert the new bulb so that its socket locates in the recess of bulb holder ⑦ and is level to it.
- ▶ Reinsert bulb holder ⑦ with the bulb in the lamp.
- ▶ Connect electric plug on the bulb.
- ▶ Align housing cover ④ and turn it clockwise.

### Replacing bulbs

#### Front turn signal lamp bulb

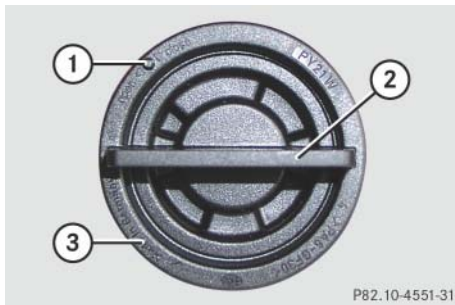

- ① Mark
- ② Handle
- ③ Bulb socket

- ▶ Turn bulb socket ③ with handle ② counterclockwise and remove it.
- ▶ Press gently onto the bulb and turn counterclockwise out of bulb socket ③.
- ▶ Press the new bulb gently into bulb socket ③ and turn clockwise until it engages.

- ▶ Place bulb socket ③ back into the lamp. Handle ② must be in a horizontal line and mark ① is on the upper part.
- ▶ Turn bulb socket ③ clockwise until it engage.

#### Parking and standing lamp bulb

- ▶ Turn housing cover ② or ③ counterclockwise and remove it.
- ▶ Pull out bulb socket ⑥ with the bulb.
- ▶ Pull the bulb out of the bulb socket ⑥.
- ▶ Press the new bulb into bulb socket ⑥.
- ▶ Press bulb socket ⑥ back into the lamp.
- ▶ Align housing cover ② or ③ and turn it clockwise.

#### Additional turn signal lamps

The additional turn signal lamps in the exterior rear view mirrors have LEDs.

If a malfunction occurs or LEDs fail to function, the entire turn signal unit must be replaced. Have the additional turn signal unit replaced at an authorized Mercedes-Benz Center.

#### Front side marker lamp

Since replacing the side marker lamp bulbs is a technically highly demanding process, we recommend you have the side marker lamp bulbs replaced at an authorized Mercedes-Benz Center.

#### Replacing bulbs for rear lamps

Before you start to replace a bulb for a rear lamp, do the following first:

- ▶ Turn the exterior lamp switch to position **0** (▷ page 108).

### Tail lamp unit

- ▶ Open trunk lid.
- ▶ For driver side: Lift up the bottom and pull out the trim panel covering the driver side rear light.
- ▶ For passenger side: Open the fuse box in the trunk (▷ page 458).

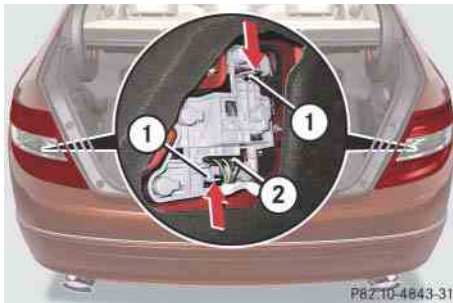

- ① Tabs
- ② Connector
- ▶ Disconnect electrical connector ②.
- ▶ Pull tabs ① in direction of arrows.
- ▶ Remove the bulb carrier.

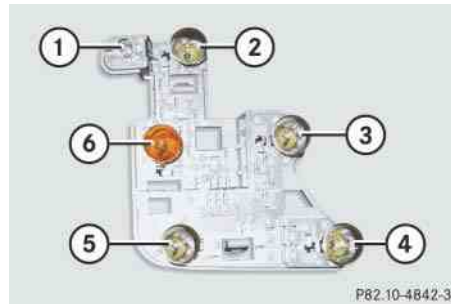

- ① Side marker lamp
  - ② Rear fog lamp (driver's side)/Side marker lamp
  - ③ Backup lamp
  - ④ Brake lamp/tail lamp
  - ⑤ Parking and standing lamp, brake lamp/tail lamp
  - ⑥ Turn signal lamp
- ▶ Press gently onto the respective bulb and turn counterclockwise out of its bulb socket.
- Side marker lamp ①: Turn the bulb socket on backside of tail lamp unit counterclockwise and removes side marker lamp ① with bulb socket

- ▶ Press the new bulb gently into its bulb socket and turn clockwise until it engages.
- Side marker lamp ①: Turn the new bulb with socket on backside of tail lamp unit clockwise until it engages.
- ▶ Reinstall the bulb carrier.
- Let tabs ① (▷ page 437) engage.
  - ▶ Connect the electrical connector ② (▷ page 437) until it engage.
  - ▶ Reinstall trim panel.

### License plate lamp

Since replacing the license plate lamp bulbs is a technically highly demanding process, we recommend you have the license plate lamp bulbs replaced at an authorized Mercedes-Benz Center.

### Replacing wiper blades

#### Warning!



For safety reasons, switch off wipers and remove SmartKey from starter switch (vehicles with KEYLESS-GO\* (Canada only): Make sure the vehicle's on-board electronics have status **0**) before replacing a wiper blade. Otherwise, the wiper motor could suddenly turn on and cause injury.

#### Warning!



Wiper blades are components that are subject to wear and tear. Change the wiper blades twice a year, preferably in the spring and fall. Otherwise the windows will not be properly wiped. As a result, you may not be able to observe surrounding traffic conditions and could cause an accident.

**!** To avoid damage to the hood, never open the hood when the wiper arm is folded forward.

**!** Hold on to the wiper when folding the wiper arm back. If released, the force of the impact from the tensioning spring could crack the windshield.

*Do not allow the wiper arms to contact the windshield glass without a wiper blade inserted.*

*For your convenience, we recommend that you have this work carried out at an authorized Mercedes-Benz Center.*

### Removing wiper blades

**!** Do not pull on the wiper blade inserts. They could tear.

- ▶ Make sure the vehicle's on-board electronic have status **0** (> page 82).
- ▶ Fold the wiper arm forward until it snaps into place.

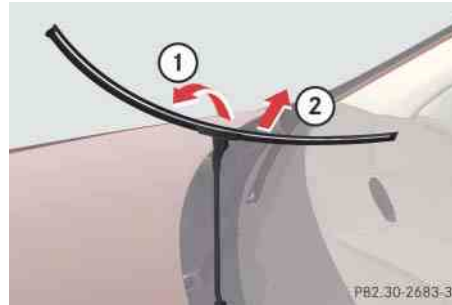

① Right angle

② Removing

- ▶ Turn the wiper blade at a right angle to wiper arm (arrow ①).
- ▶ Slide the wiper blade sideways out of the retainer in the direction of arrow ②.

### Installing wiper blades

- ▶ Slide the wiper blade onto wiper arm until it locks in place.
- ▶ Rotate the wiper blade into position parallel to wiper arm.
- ▶ Fold the wiper arm backward to rest on the windshield. Make sure you hold onto the wiper when folding the wiper arm back.

**!** Make certain that the wiper blades are properly installed. Improperly installed wiper blades may cause windshield damage.



### Flat tire

#### Warning!



The dimensions of the Minispare wheel are different from those of the road wheels. As a result, the vehicle handling characteristics change when driving with a Minispare wheel mounted. Adapt your driving style accordingly.

The Minispare wheel is for temporary use only. When driving with Minispare wheel mounted, ensure proper tire inflation pressure and do not exceed a vehicle speed of 50 mph (80 km/h).

Contact the nearest Mercedes-Benz Center as soon as possible to have the Minispare wheel replaced with a regular road wheel.

Never operate the vehicle with more than one Minispare wheel mounted.

Do not switch off the ESP<sup>®</sup> with a Minispare wheel mounted.

#### Preparing the vehicle

- ▶ Park the vehicle in a safe distance from moving traffic on a hard, flat surface when possible.
  - ▶ Turn on the hazard warning flashers.
  - ▶ Turn the steering wheel so that the front wheels are in a straight-ahead position.
  - ▶ Set the parking brake.
  - ▶ Vehicles with automatic transmission\*: Move the gear selector lever to position **P** (▷ page 138).
  - ▶ Turn off the engine (▷ page 134).
- ▶ Remove the SmartKey from the starter switch.
- Vehicles with KEYLESS-GO\*:
- ▶ Turn off the engine by pressing the KEYLESS-GO\* button once (▷ page 135).
  - ▶ Open the driver's door (this puts the starter switch in position **0**, same as with the SmartKey removed from the starter switch). The driver's door then can be closed again.

 *Open the door only when conditions are safe to do so.*

- ▶ Have any passenger exit the vehicle at a safe distance from the roadway.

## Mounting the Minispare wheel

### Preparing the vehicle

- ▶ Prepare the vehicle as described (▷ page 440).
- ▶ Take vehicle tool kit tray and vehicle jack out of trunk (▷ page 420).
- ▶ Take the Minispare wheel from the wheel well under the trunk floor (▷ page 422).

### Lifting the vehicle

#### Warning!



When jacking up the vehicle, only use the jack which has been specifically approved by Mercedes-Benz for your vehicle.

The jack is designed exclusively for jacking up the vehicle at the jack take-up brackets built into both sides of the vehicle. Make sure the jack arm is fully seated in the jack take-up bracket.

The jack is intended only for lifting the vehicle briefly for wheel changes. It is not suited for performing maintenance work under the vehicle. To help avoid personal injury, use the jack only to lift the vehicle during a wheel change.

Never get beneath the vehicle while it is supported by the jack. Keep hands and feet away from the area under the lifted vehicle. Always lower the vehicle onto sufficient capacity jackstands before working under the vehicle.

Always firmly set the parking brake and block wheels with wheel chocks or other sizeable objects before raising vehicle with jack. Do not release the parking brake while the vehicle is raised.

Make sure that the ground on which the vehicle is standing and where you place the jack is solid, level and not slippery. If necessary, use a large underlay. On slippery surfaces, such as tiled floors, you should use a non-slip underlay, for example a rubber mat.

Do not use wooden blocks or similar objects to support the jack. Otherwise the jack may not be able to achieve its load-bearing capacity if it is not at its full height.

Be certain that the jack is always vertical (plumb line) when in use, especially on hills. Always try to use the jack on level surface.

Never start the engine when the vehicle is raised.

Also observe the notes on the jack.

### Flat tire

- ▶ Prevent the vehicle from rolling away by blocking wheels with wheel chocks or other sizeable objects.

One wheel chock is included with the vehicle tool kit (▷ page 422).

#### *Changing wheel on a level surface*



#### **Changing rear wheel on passenger side (Example illustration)**

- ▶ Place the wheel chock in front of and another sizeable object behind the wheel that is diagonally opposite to the wheel being changed.

#### *Changing wheel on a slight decline*

Always try lifting the vehicle using the jack on a level surface. However, should circumstances require you to do so on a slight decline, place the wheel chock and another sizeable object as follows:



#### **Changing wheel on passenger side (Example illustration)**

- ▶ Place wheel chock (or another sizeable object) in front of both wheels on the side opposite to the side on which the wheel is to be changed.

#### *Changing wheel on a slight incline*

Always try lifting the vehicle using the jack on a level surface. However, should circumstances require you to do so on a slight incline, place the wheel chock and another sizeable object as follows:



#### **Changing wheel on passenger side (Example illustration)**

- ▶ Place wheel chock (or another sizeable object) behind both wheels on the side opposite to the side on which the wheel is to be changed.

### Jacking up

- ▶ Take the wheel wrench out of the vehicle tool kit tray.



- ▶ On wheel to be changed, loosen but do not yet remove the wheel bolts (approximately one full turn with wheel wrench).



The jack take-up brackets are located directly behind the front wheel housings and in front of the rear wheel housings as indicated by the arrows.

### Warning!



The jack is designed exclusively for jacking up the vehicle at the jack take-up brackets. Make sure the jack arm is fully seated in the jack take-up bracket.

If you do not position the jack correctly in the jack take-up bracket, the vehicle can:

- fall off the jack
- seriously or fatally injure you or others

**!** Do not position the jack on the body of the vehicle, as this may cause damage to the vehicle.

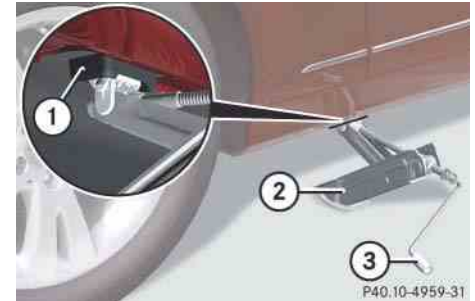

- ① Take-up bracket
- ② Jack
- ③ Crank

- ▶ Place jack ② on firm ground.
- ▶ Position jack ② under take-up bracket ① so that it is always vertical (plumb-line) as seen from the side, even if the vehicle is parked on an incline.



### Flat tire

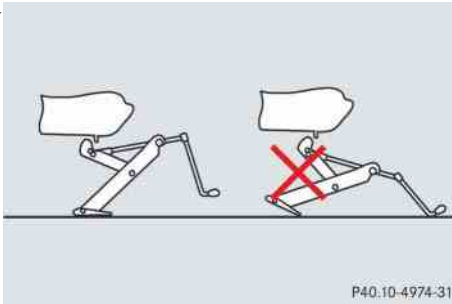

- ▶ Turn crank ③ clockwise until jack ② is fully seated in take-up bracket ① and the jack base evenly meets the ground.
- ▶ Continue to turn crank ③ until the wheel is a maximum of 1.2 in (3 cm) from the ground.

#### Removing the wheel

- ▶ Unscrew and remove the wheel bolts.

**!** Do not place wheel bolts in sand or dirt. This could result in damage to the bolt and wheel hub threads.

- ▶ Remove the wheel.

#### Mounting the Minispare wheel

- ▶ Clean contact surfaces of wheel and wheel hub.

**!** To avoid paint damage, place wheel flat against hub and hold it there while installing first wheel bolt.

#### Warning!



Always replace wheel bolts that are damaged or rusted.

Never apply oil or grease to wheel bolts.

Damaged wheel hub threads should be repaired immediately. Do not continue to drive under these circumstances! Contact an authorized Mercedes-Benz Center or call Roadside Assistance.

Incorrect wheel bolts or improperly tightened wheel bolts can cause the wheel to come off. This could cause an accident. Make sure you are using the correct wheel bolts.

#### Warning!



Only use genuine Mercedes-Benz wheel bolts. Other wheel bolts may come loose.

Do not tighten the wheel bolts when the vehicle is raised. Otherwise the vehicle could fall off the jack.



P40.10-4964-31

- ▶ Guide the Minispare wheel onto the wheel hub and push it on.
- ▶ Insert wheel bolts and tighten them slightly.

### Lowering the vehicle

- ▶ Lower vehicle by turning crank counterclockwise until vehicle is resting fully on its own weight.
- ▶ Remove the jack.



P40.10-4963-31

① - ⑤ Wheel bolts



P40.10-4962-31

⑥ Wheel wrench

- ▶ Tighten the five wheel bolts evenly, following the diagonal sequence illustrated (① to ⑤), until all bolts are tight. Observe a tightening torque of 96 lb-ft (130 Nm).

### Warning!



Have the tightening torque checked after changing a wheel. The wheels could come loose if they are not tightened to a torque of 96 lb-ft (130 Nm).

Before storing the jack, it should be fully collapsed, with handle folded in (storage position).

- ▶ Store the jack and the other vehicle tools in the designated storage space underneath the trunk floor (▷ page 420).

**i** *Vehicles with TPMS (USA only): Do not activate the tire inflation pressure monitor (▷ page 344) until a full size wheel/tire with functioning sensor has been placed back into service on the vehicle.*

### Battery

Your vehicle's battery is located in the engine compartment.

**!** *Do not tow-start the vehicle.*

The battery should always be sufficiently charged in order to achieve its rated service life. Refer to Maintenance Booklet for battery maintenance intervals.

If you use your vehicle mostly for short-distance trips, you will need to have the battery charge checked more frequently.

When replacing the battery, always use batteries approved by Mercedes-Benz.

If you do not intend to operate your vehicle for an extended period of time, consult an authorized Mercedes-Benz Center about steps you need to observe.

#### Warning!



Observe all safety instructions and precautions when handling automotive batteries.



Risk of explosion.



Fire, open flames and smoking are prohibited when handling batteries. Avoid creating sparks.



Battery acid is caustic. Do not allow it to come into contact with skin, eyes or clothing.

Wear suitable protective clothing, especially gloves, apron and faceguard.



Wear eye protection.

Rinse any acid spills immediately with clear water. Contact a physician if necessary.



Keep children away.



Follow the instructions in this Operator's Manual.

Batteries contain materials that can harm the environment if disposed of improperly. Large 12-volt storage batteries contain lead. Recycling of batteries is the preferred method of disposal. Many states require sellers of batteries to accept old batteries for recycling.

**Warning!**



Failure to follow these instructions can result in severe injury or death.

Observe all safety instructions and precautions when handling automotive batteries (▷ page 446).

Never lean over batteries while connecting, you might get injured.

Battery fluid contains sulfuric acid. Do not allow this fluid to come in contact with eyes, skin or clothing. In case it does, immediately flush affected area with water and seek medical help if necessary.

A battery will also produce hydrogen gas, which is flammable and explosive. Keep flames or sparks away from battery, avoid improper connection of jumper cables, smoking, etc.

**!** Never loosen or detach battery terminal clamps while the engine is running or the SmartKey is in the starter switch. Otherwise the alternator and other electronic components could be severely damaged.

Have the battery checked regularly at an authorized Mercedes-Benz Center.

Refer to Maintenance Booklet for maintenance intervals or contact an authorized Mercedes-Benz Center for further information.

**Warning!**



Do not place metal objects on the battery as this could result in a short circuit.

Use leak-proof batteries only to avoid the risk of acid burns in the event of an accident.

**!** Do not connect any consumers directly to the battery or it will be discharged.



- ① Filter box
- ② Clamps

- ▶ **Removing filter box:** Release clamps ②.
- ▶ Remove filter box.
- ▶ **Installing filter box:** Insert filter box properly.
- ▶ Secure it with clamps ②.



### Battery

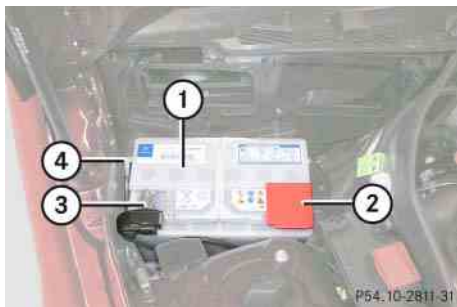

#### Starter battery

- ① Battery
- ② Positive terminal
- ③ Negative terminal
- ④ Ventilation hose

**i** If the battery is discharged, you must use the mechanical key to unlock (▷ page 424) or lock (▷ page 425) the vehicle.

#### Disconnecting the battery

##### Warning!



With a disconnected battery

- you will no longer be able to turn the SmartKey in the starter switch and pressing the KEYLESS-GO\* start/stop button (Canada only) will have no effect
- vehicles with automatic transmission\*: the gear selector lever will remain locked in position **P**

**!** Always disconnect the starter battery in the order described below. You could otherwise damage the vehicle's electronics.

- ▶ Apply the parking brake (▷ page 134).
- ▶ Make sure gear selector lever\* is set to position **P** (manual transmission to Neutral).
- ▶ Turn off all electrical consumers.
- ▶ Remove SmartKey from starter switch.

Vehicles with KEYLESS-GO\* (Canada only):

- ▶ Press the start/stop button until the engine shuts off.
- ▶ Open the driver's door.
- ▶ Open the hood (▷ page 325).
- ▶ Remove the filter box (▷ page 447).
- ▶ Read and observe safety instructions and precautions (▷ page 446).
- ▶ Disconnect the battery negative lead from negative terminal ③.
- ▶ Remove cover from the positive terminal ②.
- ▶ Disconnect the battery positive lead.

## Removing the battery

 For your convenience, have the starter battery removed by a Mercedes-Benz Center.

- ▶ Remove the screw securing the battery.
- ▶ Remove the battery support and bracket.
- ▶ Pull out the battery ventilation hose ④ from the battery (depending on battery arrangement in your vehicle model, the ventilation hose is located either on the left or right side of the battery).
- ▶ Take out the battery.

## Charging and reinstalling the battery

### Warning!



Never charge a battery while still installed in the vehicle unless the accessory battery charge unit approved by Mercedes-Benz is being used. Gases may escape during charging and cause explosions that may result in paint damage, corrosion or personal injury.

An accessory battery charge unit specially adapted for Mercedes-Benz vehicles and tested and approved by Mercedes-Benz is available, permitting the charging of the battery in its installed position. Contact an authorized Mercedes-Benz Center for information and availability. Charge battery in accordance with the separate instructions for the accessory battery charger.

 Only use charging devices with a maximum charging voltage of 14.8 V.

- ▶ Charge battery in accordance with the instructions of the battery charger manufacturer.
- ▶ Reinstall the charged battery. Follow the previously described steps in reverse order.

 *The battery, its filler caps and the ventilation hose ④ must always be securely installed when the vehicle is in operation.*

### Battery

#### Reconnecting the battery

**!** Always connect the starter battery in the order described below. Otherwise, the vehicle's electronics could be damaged.

- ▶ Turn off all electrical consumers.
- ▶ Remove SmartKey from starter switch.

Vehicles with KEYLESS-GO\* (Canada only):

- ▶ Open the driver's door.

**!** Never invert the terminal connections.

- ▶ Connect the battery positive lead and fasten its cover (▷ page 448).
- ▶ Connect the battery negative lead (▷ page 448).
- ▶ Make sure that the ventilation hose ④ is attached to the battery.

**!** Make sure the battery has a plug where the ventilation hose ④ is attached to it.

- ▶ Reinstall filter box (▷ page 447).

**i** The following procedures must be carried out following any interruption of battery power (e.g. due to reconnecting):

- Reset the automatic exterior mirror fold in function (▷ page 99).
- Set the clock (▷ page 170).  
Vehicles with COMAND\*: see COMAND operator's manual.

## ▼ Jump starting

### Warning!



Failure to follow these directions will cause damage to the electronic components, and can lead to a battery explosion and severe injury or death.

Never lean over batteries while connecting or jump starting, you might get injured.

Battery fluid contains sulfuric acid. Do not allow this fluid to come in contact with eyes, skin or clothing. In case it does, immediately flush affected area with water, and seek medical help if necessary.

A battery will also produce hydrogen gas, which is flammable and very explosive. Keep flames or sparks away from battery, avoid improper connection of jumper cables, smoking, etc.

Attempting to jump start a frozen battery can result in it exploding, causing personal injury.

Read all instructions before proceeding.

**!** *Vehicles with automatic transmission\* and/or 4MATIC:*

*Do not tow-start the vehicle.*

**!** *Avoid repeated and lengthy starting attempts.*

*Do not attempt to start the engine using a battery quick charge unit.*

*If engine does not run after several unsuccessful starting attempts, have it checked at the nearest authorized Mercedes-Benz Center.*

*Excessive unburned fuel generated by repeated failed starting attempts may damage the catalytic converter and may present a fire risk.*

*Make sure the jumper cables do not have loose or missing insulation.*

*Make sure the cable clamps do not touch any other metal part while the other end is still attached to a battery.*

If the battery is discharged, the engine can be started with jumper cables and the battery of another vehicle. Observe the following:

- Jump starting should only be performed when the engine and catalytic converter are cold.

- Do not start the engine if the battery is frozen. Let the battery thaw out first.
- Only use a 12-volt battery to jump start your vehicle. Jump starting with a higher voltage battery could damage the vehicle's electrical system, which will not be covered by the Mercedes-Benz Limited Warranty.
- Only use jumper cables with sufficient cross-section and insulated terminal clamps.
- Always make sure the jumper cables are not on or near pulleys, fans or other parts that move when an engine is started or running.

### Warning!



Keep flames or sparks away from battery. Do not smoke.

Observe all safety instructions and precautions when handling automotive batteries (▷ page 446).

### Jump starting

The battery is located in the engine compartment on the right hand side. For jump starting, use the under hood terminals in front of the battery.

- ▶ Make sure the two vehicles do not touch.
- ▶ Turn off all electrical consumers, except hazard warning flashers or work lights.
- ▶ Apply the parking brake (▷ page 134).
- ▶ Make sure gear selector lever\* is set to position **P** (manual transmission to Neutral).
- ▶ Open the hood (▷ page 326).
- ▶ Slide red cover ② from positive under hood terminal ③ in direction of arrow.

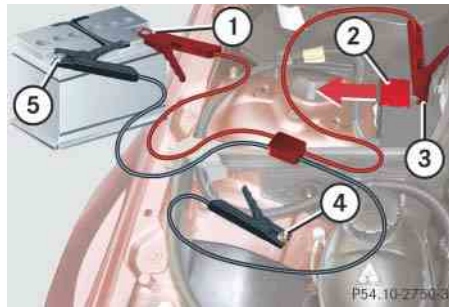

- ① Positive terminal of charged battery
- ② Positive under hood terminal cover
- ③ Positive under hood terminal in front of discharged battery
- ④ Negative under hood terminal
- ⑤ Negative terminal of charged battery

**!** *Never invert the terminal connections.*

- ▶ Connect positive terminal ① of the charged battery with positive under hood terminal ③ in front of the discharged battery with the jumper cable. Clamp cable to charged battery ① first.
- ▶ Start the engine of the vehicle with the charged battery and run at idle speed.

- ▶ Connect negative terminal ⑤ of the charged battery to jumper cables and attach other end to negative under hood terminal ④ on the vehicle. Clamp cable to charged battery ⑤ first
- ▶ Start the engine of the disabled vehicle.

You can now turn on the electrical consumers. Do not switch on the headlamps under any circumstances.

- ▶ Remove the jumper cables first from the negative terminals ④ and ⑤ and then from the positive terminals ③ and ①.

You can now switch on the headlamps.

- ▶ Slide red cover ② from positive under hood terminal ③ back.
- ▶ Close the hood (▷ page 326).
- ▶ Have the battery checked at the nearest authorized Mercedes-Benz Center.

## ▼ Towing the vehicle

Mercedes-Benz recommends that the vehicle be transported with all wheels off the ground using flatbed or appropriate wheel lift/dolly equipment. This method is preferable to other types of towing.

**!** *Vehicles with automatic transmission\* and/or 4MATIC:  
Do not tow-start the vehicle.*

**!** *Use flatbed or wheel lift/dolly equipment with SmartKey or SmartKey with KEYLESS-GO\* (Canada only) in starter switch turned to position 0.*

*Do not tow with sling-type equipment. Towing with sling-type equipment over bumpy roads will damage radiator and supports.*

*To prevent damage during transport, do not tie down vehicle by its chassis or suspension parts.*

*Switch off the ESP® (▷ page 63) and the automatic central locking (▷ page 173).*

When circumstances do not permit the recommended towing methods, the vehicle may be towed with all wheels on the ground or front wheels raised (except vehicles with 4MATIC) only so far as necessary to have the vehicle moved to a safe location where the recommended towing methods can be employed.

When towing the vehicle with all wheels on the ground or the front axle raised (not permissible for vehicles with 4MATIC), the vehicle may be towed only for distances up to 30 miles (50 km) and at a speed not to exceed 30 mph (50 km/h).

**!** *Vehicles with 4MATIC:  
Do not tow with one axle raised. Doing so could damage the transfer case, which is not covered by the Mercedes-Benz Limited Warranty.*

*All wheels must be on or off the ground. Observe instructions for towing the vehicle with all wheels on the ground.*

### Warning!



If circumstances require towing the vehicle with all wheels on the ground, always tow with a tow bar if:

- the engine will not run
- there is a malfunction in the brake system
- there is a malfunction in the power supply or in the vehicle's electrical system

This is necessary to adequately control the towed vehicle.

Prior to towing the vehicle with all wheels on the ground, make sure the SmartKey or SmartKey with KEYLESS-GO\* (Canada only) is in starter switch position 2.

### Towing the vehicle

#### Warning!



Without the engine running, there is no power assistance for the brake and steering systems. In this case, it is important to keep in mind that a considerably higher degree of effort is necessary to brake and steer the vehicle. Adapt your driving accordingly.

**i** When towing the vehicle with all wheels on the ground, please note the following:

With the automatic central locking activated and the SmartKey or SmartKey with KEYLESS-GO\* (Canada only) in starter switch position **2**, the vehicle doors lock if the left front wheel as well as the right rear wheel are turning at vehicle speeds of approximately 9 mph (15 km/h) or more.

To prevent the vehicle doors from locking, deactivate the automatic central locking (▷ page 173).

**!** If the vehicle is towed with the front axle raised (not permissible for vehicles with 4MATIC), the gear selector lever must be in position **N** (manual transmission: gear shift lever in neutral position) and the engine must be shut off (SmartKey or SmartKey with KEYLESS-GO\* (Canada only) in starter switch position **0** or **1**). Active braking action through the ESP® may otherwise seriously damage the brake system.

While towing, the battery must be connected and charged. Otherwise:

- you will not be able to switch on the ignition
- you will not be able to engage the automatic transmission\* in position **N** (▷ page 127)

When towing the vehicle with all wheels on the ground, the gear selector lever must be in position **N** (manual transmission: gear shift lever in neutral position) and the SmartKey or SmartKey with KEYLESS-GO\* (Canada only) must be in starter switch position **2**.

**!** Towing of the vehicle should only be done using the properly installed towing eye bolt. Never attach tow cable, tow rope or tow rod to vehicle chassis, frame or suspension parts.

**i** To signal turns while being towed with the hazard warning flasher in use, turn SmartKey or SmartKey with KEYLESS-GO\* (Canada only) in starter switch to position **2** and activate the combination switch for the left or right turn signal in the usual manner – only the selected turn signal will operate.

Upon canceling the turn signal, the hazard warning flasher will operate again.

**!** Make sure the parking brake is released.

- i** If the battery is disconnected or discharged
- the SmartKey or SmartKey with KEYLESS-GO\* (Canada only) will not turn in the starter switch
  - Vehicles with automatic transmission\*: the gear selector lever will remain locked in position **P** (▷ page 127).

For more information see “Battery” (▷ page 446) and see “Jump starting” (▷ page 451).

**Installing towing eye bolt**



① Cover on right side of front bumper

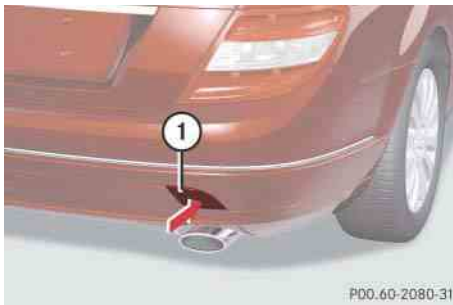

① Cover on right side of rear bumper

**Removing cover**

- ▶ Press mark on cover ① in the direction of arrow.
- ▶ Lift cover off to reveal the threaded hole for towing eye bolt.

**Installing towing eye bolt**

- ▶ Take towing eye bolt and wheel wrench out of the vehicle tool kit in the trunk (▷ page 420).
- ▶ Screw towing eye bolt clockwise into its stop and tighten with wheel wrench.

**Removing towing eye bolt**

- ▶ Loosen towing eye bolt counterclockwise with wheel wrench.
- ▶ Unscrew towing eye bolt.
- ▶ Store towing eye bolt and wheel wrench in the vehicle tool kit in the trunk.

**Installing cover**

- ▶ Fit cover ① and snap into place.



### Fuses

The electrical fuses in your vehicle serve to switch off malfunctioning power circuits.

If a fuse is blown, the component(s) and systems secured by that fuse will stop operating.

#### Warning!



Only use fuses approved by Mercedes-Benz with the specified amperage for the system in question and do not attempt to repair or bridge a blown fuse. Using other than approved fuses or using repaired or bridged fuses may cause an overload leading to a fire, and/or cause damage to electrical components and/or systems. Have the cause determined and remedied at an authorized Mercedes-Benz Center.

**i** A blown fuse must be replaced by an appropriate spare fuse (recognizable by its color or the fuse rating given on the fuse) of the amperage recommended in the fuse chart. Any Mercedes-Benz Center will be glad to advise you on this subject.

**!** Switch off the vehicle's internal electrical functions (▷ page 448) when you are working on the fuses.

If a newly inserted fuse blows again, have the cause determined and rectified at an authorized Mercedes-Benz Center.

A fuse chart explains the fuse allocation and fuse amperages. It is located in the main fuse box in the passenger compartment (▷ page 457).

**i** In case of a blown fuse contact Roadside Assistance or an authorized Mercedes-Benz Center.

The electrical fuses are located in different fuse boxes:

- Fuse box in passenger compartment (▷ page 457)
- Fuse box in engine compartment (▷ page 457)
- Fuse box in trunk (▷ page 458)

Before replacing fuses:

- ▶ Depress the parking brake (▷ page 134).
- ▶ Make sure the manual transmission is in Neutral (▷ page 136), automatic transmission\* is set to **P** (▷ page 140).  
The gear position indicator in the tachometer display should be on **P**.
- ▶ Turn off all electrical consumers.
- ▶ Turn off the engine (▷ page 134).
- ▶ Remove the SmartKey from the starter switch.

Vehicles with KEYLESS-GO\* (Canada only):

- ▶ Open the driver's door.

### Fuse box in passenger compartment

**!** Do not use sharp objects such as a screw driver to open the fuse box cover in the dashboard, as this could damage it.

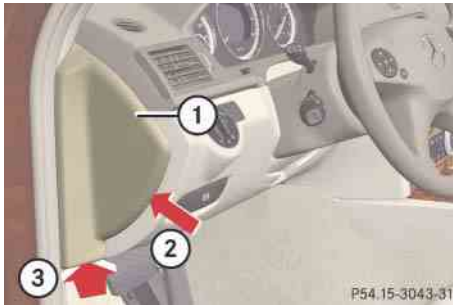

- ① Cover
- ② Remove cover
- ③ Release cover

### Opening

- ▶ Open the driver's door.
- ▶ Using your hands, pull cover ① in the direction of arrow ③ and remove ②.

### Closing

- ▶ Hook cover ① into the opening at the front.
- ▶ Press cover ① back on until it engages.

### Fuse box in engine compartment

- ▶ Open the hood (▷ page 325).



- ① Clamps
- ② Wire

### Opening

- ▶ With a dry cloth, remove any moisture from the fuse box.
- ▶ Release wire ② from fuse box cover.
- ▶ Release clamps ①.
- ▶ Remove fuse box cover.

### Closing

- ▶ Make sure the sealing rubber is properly positioned.
- ▶ Attach fuse box cover.
- ▶ Press fuse box cover down and secure with clamps ①.
- ▶ Fasten wire ② on fuse box cover.

**!** The cover must fit properly, as otherwise moisture or dirt may impair the functionality of the fuses.

### Fuses

#### Fuse box in the trunk

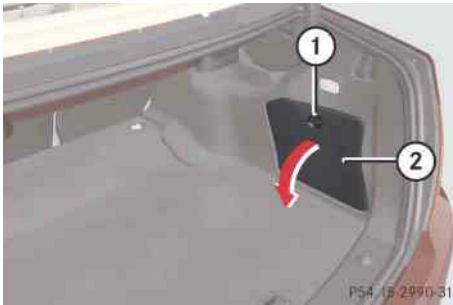

- ① Release
- ② Cover

#### Opening

- ▶ Open the trunk.
- ▶ Turn release ① clockwise.
- ▶ Pull cover ② downward in direction of arrow.

#### Closing

- ▶ Press cover ② backward.
- ▶ Turn release ① counterclockwise.

**Parts service**

**Warranty coverage**

**Identification labels**

**Layout of poly-V-belt drive**

**Engine**

**Rims and tires**

**Electrical system**

**Main dimensions and weights**

**Fuels, coolants, lubricants, etc.**



The “Technical data” section provides the necessary technical data for your vehicle.

All authorized Mercedes-Benz Centers maintain a stock of Genuine Mercedes-Benz Parts required for maintenance and repair work. In addition, strategically located parts distribution centers provide quick and reliable parts service.

More than 300 000 different parts for Mercedes-Benz models are available.

Genuine Mercedes-Benz Parts are subjected to stringent quality inspections. Each part has been specifically developed, manufactured or selected for and adapted to Mercedes-Benz vehicles.

Therefore, Genuine Mercedes-Benz parts should be installed.

**!** *The use of non-genuine Mercedes-Benz parts and accessories not authorized by Mercedes-Benz could damage the vehicle, which is not covered by the Mercedes-Benz Limited Warranty, or could compromise the vehicle's durability or safety.*

## ▼ Warranty coverage

Your vehicle is covered under the terms of the warranties printed in the Service and Warranty Information booklet. Your authorized Mercedes-Benz Center will exchange or repair any defective parts originally installed on the vehicle in accordance with the terms of the following warranties:

- New Vehicle Limited Warranty
- Emission System Warranty
- Emission Performance Warranty
- California, Maine, Massachusetts, and Vermont Emission Control Systems Warranty

Replacement parts and accessories are covered by the Mercedes-Benz Parts and Accessories warranties, copies of which are available at any authorized Mercedes-Benz Center.

## Loss of Service and Warranty Information Booklet

---

Should you lose your Service and Warranty Information booklet, have an authorized Mercedes-Benz Center arrange for a replacement. It will be mailed to you.

## Identification labels



① Certification label (on driver's B-pillar)

The Vehicle Identification Number (VIN) can be found in the following locations:

- on the certification label
- embossed underneath the carpet in front of the front passenger seat.
- on the lower edge of the windshield

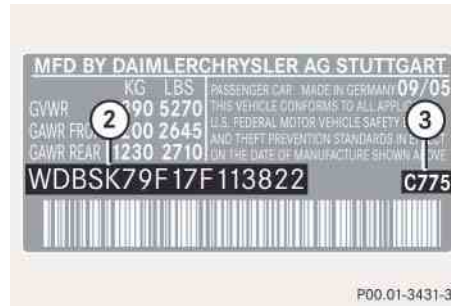

**Example certification label (U.S. vehicles)**

- ② VIN
- ③ Paintwork code



**Example certification label (Canada vehicles)**

- ② VIN
- ③ Paintwork code

**i** Data shown on certification label are for illustration purpose only. These data are specific to each vehicle and may vary from data shown in the illustration. Refer to certification label on vehicle for actual data specific to your vehicle.

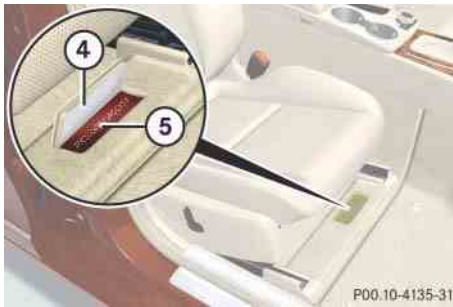

④ Carpet

⑤ VIN

- ▶ Move the front passenger seat to the rear as far as possible.
- ▶ Fold carpet ④ in direction of arrow. VIN ⑤ is visible.



**Example illustration from C 350**

⑥ Emission control information label, includes both federal and California certification exhaust emission standards

⑦ Engine number (engraved on engine)

⑧ VIN (lower edge of windshield)

**i** When ordering parts, please specify vehicle identification and engine numbers.



### Layout of poly-V-belt drive

C 300/C 350

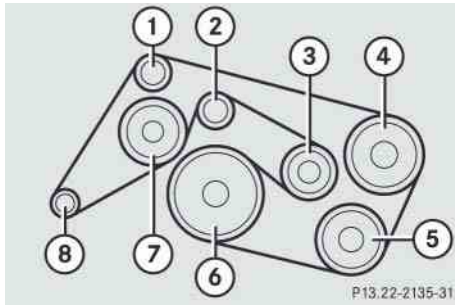

- ① Idler pulley
- ② Idler pulley
- ③ Automatic belt tensioner
- ④ Power steering pump
- ⑤ Air conditioning compressor
- ⑥ Crankshaft
- ⑦ Coolant pump
- ⑧ Generator (alternator)

▼ Engine

<b>Model</b>	C 230 (204.052) <sup>1,2</sup> C 230 Sport (204.052) <sup>1</sup> C 230 4MATIC (204.085) <sup>1,2</sup> C 230 4MATIC Sport (204.085) <sup>1,2</sup>	C 300 (204.054) <sup>1</sup> C 300 Sport (204.054) <sup>1</sup> C 300 4MATIC (204.081) <sup>1</sup> C 300 4MATIC Sport (204.081) <sup>1</sup>
<b>Engine</b>	272	272
<b>Mode of operation</b>	4-stroke engine, gasoline injection	4-stroke engine, gasoline injection
<b>No. of cylinders</b>	6	6
<b>Bore</b>	3.46 in (88.00 mm)	3.46 in (88.00 mm)
<b>Stroke</b>	2.69 in (68.40 mm)	3.23 in (82.10 mm)
<b>Total piston displacement</b>	152.3 cu in (2496 cm <sup>3</sup> )	182.8 cu in (2996 cm <sup>3</sup> )
<b>Compression ratio</b>	11.4:1	11.3:1
<b>Output acc. to SAE J 1349<sup>3</sup></b>	201 hp/6 100 rpm (150 kW/6 100 rpm)	228 hp/6 000 rpm (170 kW/6 000 rpm)
<b>Maximum torque acc. to SAE J 1349</b>	181 lb-ft/2 900 - 5 500 rpm (245 Nm/2 900 - 5 500 rpm)	221 lb-ft/2 500 - 5 000 rpm (300 Nm/2 500 - 5 000 rpm)
<b>Maximum engine speed</b>	6 500 rpm	6 500 rpm
<b>Firing order</b>	1-4-3-6-2-5	1-4-3-6-2-5
<b>Poly-V-belt</b>	2404 mm	2404 mm

<sup>1</sup> The quoted data apply only to the standard vehicle. See an authorized Mercedes-Benz Center for the corresponding data of all special bodies and special equipment.

<sup>2</sup> Canada only.

<sup>3</sup> Premium fuel required. Performance may vary with fuel octane rating.

## Engine

<b>Model</b>	C 350 (204.056) <sup>1,2</sup> C 350 Sport (204.056) <sup>1</sup> C 350 4MATIC (204.087) <sup>1,2</sup> C 350 4MATIC Sport (204.087) <sup>1,2</sup>
<b>Engine</b>	272
<b>Mode of operation</b>	4-stroke engine, gasoline injection
<b>No. of cylinders</b>	6
<b>Bore</b>	3.66 in (92.90 mm)
<b>Stroke</b>	3.39 in (86.00 mm)
<b>Total piston displacement</b>	213.5 cu in (3498 cm <sup>3</sup> )
<b>Compression ratio</b>	10.7:1
<b>Output acc. to SAE J 1349<sup>3</sup></b>	268 hp/6 000 rpm (200 kW/6 000 rpm)
<b>Maximum torque acc. to SAE J 1349</b>	258 lb-ft/2 400 - 5 000 rpm (350 Nm/2 400 - 5 000 rpm)
<b>Maximum engine speed</b>	6 500 rpm
<b>Firing order</b>	1-4-3-6-2-5
<b>Poly-V-belt</b>	2 404 mm

<sup>1</sup> The quoted data apply only to the standard vehicle. See an authorized Mercedes-Benz Center for the corresponding data of all special bodies and special equipment.

<sup>2</sup> Canada only.

<sup>3</sup> Premium fuel required. Performance may vary with fuel octane rating.

## ▼ Rims and tires

**!** Only use tires which have been tested and approved for your vehicle by Mercedes-Benz. Tires approved by Mercedes-Benz are developed to provide best possible performance in conjunction with the driving safety systems on your vehicle such as ABS or ESP®. Tires specially developed for your vehicle and tested and approved by Mercedes-Benz can be identified by finding the following on the tire's sidewall:

- MO = Mercedes-Benz Original equipment tires

Using tires other than those approved by Mercedes-Benz may result in damage that is not covered by the Mercedes-Benz Limited Warranty.

**!** Using tires other than those approved by Mercedes-Benz can have detrimental effects, such as

- poor handling characteristics
- increased noise
- increased fuel consumption

Moreover, tires and rims not approved by Mercedes-Benz may, under load, exhibit dimensional variations and different tire deformation characteristics that could cause them to come into contact with the vehicle body or axle parts. Damage to the tires or the vehicle may be the result.

**i** Further information on tires and rims is available at any authorized Mercedes-Benz Center. A placard with the recommended tire inflation pressures is located on the driver's door B-pillar (▷ page 334). Some vehicles may have supplemental tire inflation pressure information for driving at high speeds (▷ page 340) or for vehicle loads less than the maximum loaded vehicle condition (▷ page 348). If such information is provided, it can be found on the tire inflation label located on the inside of the fuel filler flap.

The tire inflation pressure should be checked regularly and should only be adjusted on cold tires. Follow tire manufacturer's maintenance recommendation included with vehicle.

**i** The following pages also list the approved wheel rim and tire sizes for equipping your vehicles with winter tires. Winter tires are not available as standard or optional factory equipment, but can be purchased from an authorized Mercedes-Benz Center.

Depending on vehicle model and the standard or optional factory-equipped wheel rim/tire configuration on your vehicle (Appearance Package, Sport Package etc.), equipping your vehicle with winter tires approved for your vehicle model may also require the purchase of two or four wheel rims of the recommended size for use with these winter tires. Contact an authorized Mercedes-Benz Center for more information.

## Rims and tires

### Same size tires

Model	C 230 <sup>1</sup> C 230 4MATIC <sup>1</sup>	C 300 C 300 4MATIC	C 350 <sup>1</sup> C 350 4MATIC <sup>1</sup>
<b>Rims (light alloy)</b>	7 J x16 H2	7.5 J x17 H2	7.5 J x17 H2
<b>Wheel offset</b>	1.85 in (47 mm)	1.85 in (47 mm)	1.85 in (47 mm)
<b>All-season tires<sup>2</sup></b>	205/55 R16 91H M+S	225/45 R17 91H M+S	-
<b>Winter tires<sup>2,3</sup></b>	205/55 R16 91H M+S 	225/45 R17 91H M+S 	225/45 R17 91H M+S 

<sup>1</sup> Canada only.

<sup>2</sup> Radial-ply tires.

<sup>3</sup> Not available as factory equipment.

Mixed size tires

<b>Model</b>	<b>C 230 Sport<sup>1</sup></b> <b>C 230 4MATIC Sport<sup>1</sup></b> <b>C 300 Sport</b> <b>C 300 4MATIC Sport</b> <b>C 350<sup>1</sup></b> <b>C 350 4MATIC<sup>1</sup></b>
--------------	---

**Front axle:**

<b>Rims (light alloy)</b>	7.5 J x 17 H2
<b>Wheel offset</b>	1.85 in (47 mm)
<b>All-season tires<sup>2</sup></b>	225/45 R17 91H M+S

**Rear axle:**

<b>Rims (light alloy)</b>	8.5 J x 17 H2
<b>Wheel offset</b>	2.28 in (58 mm)
<b>All-season tires<sup>2</sup></b>	245/40 R17 91H M+S

<sup>1</sup> Canada only.

<sup>2</sup> Radial-ply tires.

## Rims and tires

Model	C 350 Sport* C 350 4MATIC Sport* <sup>1</sup>	C 300 Sport* C 300 4MATIC Sport* C 350 Sport* C 350 4MATIC Sport* <sup>1</sup>
-------	--	---

### Front axle:

<b>AMG rims (light alloy)</b>	7.5 J x 17 H2	8 J x 18 H2
<b>Wheel offset</b>	1.85 in (47 mm)	1.97 in (50 mm)
<b>Summer tires<sup>2</sup></b>	-	225/40 ZR18 92Y XL (Extra Load)
<b>All-season tires<sup>2</sup></b>	225/45 R17 91H M+S	-

### Rear axle:

<b>AMG rims (light alloy)</b>	8.5 J x 17 H2	8.5 J x 18 H2
<b>Wheel offset</b>	2.28 in (58 mm)	2.13 in (54 mm)
<b>Summer tires<sup>2,3</sup></b>	-	255/35 ZR18 94Y XL (Extra Load)
<b>All-season tires<sup>2</sup></b>	245/40 R17 91H M+S	-

<sup>1</sup> Canada only.

<sup>2</sup> Radial-ply tires.

<sup>3</sup> Must not be used with snow chains.

Minispare wheel

<b>Model</b>	<b>C 230<sup>1</sup></b> <b>C 230 Sport<sup>1</sup></b> <b>C 230 4MATIC<sup>1</sup></b> <b>C 230 4MATIC Sport<sup>1</sup></b> <b>C 300</b> <b>C 300 Sport</b> <b>C 300 4MATIC</b> <b>C 300 4MATIC Sport</b>	<b>C 350<sup>1</sup></b> <b>C 350 Sport</b> <b>C 350 4MATIC<sup>1</sup></b> <b>C 350 4MATIC Sport<sup>1</sup></b>
<b>Rim (steel)</b>	3.5 B x 16 H2	3.5 B x 17 H2
<b>Wheel offset</b>	0.79 in (20 mm)	0.79 in (20 mm)
<b>Tire<sup>2</sup></b>	T 125/90 R16 98M	T 125/80 R17 99M

<sup>1</sup> Canada only.

<sup>2</sup> Must not be used with snow chains.



### Rims and tires

**!** *Please compare the recommended tire inflation pressure for your vehicle with the tire inflation pressure on the yellow label located on the Minispare wheel rim.*

*If the tire inflation pressure on the yellow label on the Minispare wheel rim differs from the values given in this Operator's Manual, inflate the Minispare wheel tire to the recommended tire inflation pressure given on the yellow label on the Minispare wheel rim.*

**i** *Please note that the tire inflation pressure of the Minispare differs from the tire inflation pressure of the road tires.*

*Make sure the Minispare tire is inflated to approximately 61 psi (4.2 bar).*

▼ Electrical system

Model	C 230 <sup>1</sup> C 230 Sport <sup>1</sup> C 230 4MATIC <sup>1</sup> C 230 4MATIC Sport <sup>1</sup>	C 300 C 300 Sport C 300 4MATIC C 300 4MATIC Sport	C 350 <sup>1</sup> C 350 Sport C 350 4MATIC <sup>1</sup> C 350 4MATIC Sport <sup>1</sup>
Generator (alternator)	14 V/150 A	14 V/150 A	14 V/150 A
Starter motor	12 V/1.4 kW	12 V/1.4 kW	12 V/1.4 kW
Battery	12 V/84 Ah	12 V/84 Ah	12 V/84 Ah
Spark plugs	NGK PLKR 6A Bosch Platin Y 7 MPP 33	NGK PLKR 6A Bosch Platin Y 7 MPP 33	NGK PLKR 6A Bosch Platin Y 7 MPP 33
Electrode gap	0.031 in (0.8 mm)	0.031 in (0.8 mm)	0.031 in (0.8 mm)
Tightening torque	15 – 22 lb-ft (20 – 30 Nm)	15 – 22 lb-ft (20 – 30 Nm)	15 – 22 lb-ft (20 – 30 Nm)

<sup>1</sup> Canada only.

## Main dimensions and weights

### Main dimensions

Model	C 230 <sup>1</sup>	C 230 Sport <sup>1</sup> C 350 4MATIC Sport <sup>1</sup>	C 300	C 300 4MATIC
<b>Overall vehicle length</b>	180.6 in (4586 mm)	180.6 in (4586 mm)	182.3 in (4630 mm)	182.3 in (4630 mm)
<b>Overall vehicle width (exterior rear view mirrors folded out)</b>	79.5 in (2020 mm)	79.5 in (2020 mm)	79.5 in (2020 mm)	79.5 in (2020 mm)
<b>Overall vehicle width (exterior rear view mirrors folded in)</b>	69.7 in (1770 mm)	69.7 in (1770 mm)	69.7 in (1770 mm)	69.7 in (1770 mm)
<b>Overall vehicle height</b>	56.85 in (1444 mm)	56.3 in (1429 mm)	56.85 in (1444 mm)	56.9 in (1445 mm)
<b>Wheelbase</b>	124.6 in (2760 mm)	124.6 in (2760 mm)	124.6 in (2760 mm)	124.6 in (2760 mm)
<b>Track, front</b>	60.7 in (1541 mm)	60.4 in (1533 mm)	60.7 in (1541 mm)	60.7 in (1541 mm)
<b>Track, rear</b>	60.8 in (1544 mm)	59.6 in (1514 mm)	60.8 in (1544 mm)	60.8 in (1544 mm)

<sup>1</sup> Canada only.

Main dimensions and weights

Model	C 300 Sport C 300 4MATIC Sport C 350 Sport	C 350 <sup>1</sup>	C 350 4MATIC <sup>1</sup>	C 230 4MATIC <sup>1</sup> C 230 4MATIC Sport <sup>1</sup>
Overall vehicle length	182.3 in (4630 mm)	182.3 in (4630 mm)	180.6 in (4586 mm)	
Overall vehicle width (exterior rear view mirrors folded out)	79.5 in (2020 mm)	79.5 in (2020 mm)	79.5 in (2020 mm)	
Overall vehicle width (exterior rear view mirrors folded in)	69.7 in (1770 mm)	69.7 in (1770 mm)	69.7 in (1770 mm)	
Overall vehicle height	56.3 in (1429 mm)	57.0 in (1448 mm)	57.1 in (1449 mm)	
Wheelbase	124.6 in (2760 mm)	124.6 in (2760 mm)	124.6 in (2760 mm)	
Track, front	60.4 in (1533 mm)	60.4 in (1533 mm)	60.4 in (1533 mm)	
Track, rear	59.6 in (1514 mm)	60.5 in (1536 mm)	60.5 in (1536 mm)	

<sup>1</sup> Canada only.

Weights

Max. roof load	220 lb (100 kg)
Max. trunk load	220 lb (100 kg)

### Fuels, coolants, lubricants, etc.

#### Capacities

Vehicle components and their respective lubricants must match. Therefore only use products tested and approved by Mercedes-Benz.

Please refer to the Factory Approved Service Products pamphlet (USA only), or inquire at an authorized Mercedes-Benz Center.

#### Warning!



Comply with all valid regulations with respect to handling, storing and disposing of service fluids. Otherwise you could endanger persons or the environment.

Keep service fluids out of the reach of children.

For health reasons, you should prevent service fluids from coming into direct contact with your skin or clothing.

If a service fluid is swallowed, contact a physician immediately.

	Model	Capacity	Fuels, coolants, lubricants, etc.
<b>Engine with oil filter</b>	All models	8.5 US qt. (8.0 l)	Approved engine oils
<b>Manual transmission</b>	C 230 <sup>1</sup>	1.3 US qt. (1.2 l)	MB Manual Transmission Oil
	C 230 Sport <sup>1</sup>	1.3 US qt. (1.2 l)	
	C 300	1.6 US qt. (1.5 l)	
	C 300 Sport	1.6 US qt. (1.5 l)	

<sup>1</sup> Canada only.

Fuels, coolants, lubricants, etc.

	Model	Capacity	Fuels, coolants, lubricants, etc.
Automatic transmission	C 230 (all models) <sup>1</sup>	9.51 US qt. (9.0 l)	MB Automatic Transmission Fluid
	C 300	9.51 US qt. (9.0 l)	
	C 300 Sport	9.51 US qt. (9.0 l)	
	C 300 4MATIC	10.25 US qt. (9.7 l)	
	C 300 4MATIC Sport	10.25 US qt. (9.7 l)	
	C 350 <sup>1</sup>	9.51 US qt. (9.0 l)	
	C 350 Sport	9.51 US qt. (9.0 l)	
	C 350 4MATIC <sup>1</sup>	10.25 US qt. (9.7 l)	
	C 350 4MATIC Sport <sup>1</sup>	10.25 US qt. (9.7 l)	
Rear axle	C 230 (all models) <sup>1</sup>	1.06 US qt. (1.0 l)	Hypoid gear oil SAE 85 W 90
	C 300 (all models)	1.06 US qt. (1.0 l)	
	C 350 (all models)	1.16 US qt. (1.1 l)	
Front axle	C 230 4MATIC (all models) <sup>1</sup>	1.06 US qt. (1.0 l)	Hypoid gear oil SAE 85 W 90
	C 300 4MATIC (all models)	1.16 US qt. (1.1 l)	
	C 350 4MATIC (all models)	1.16 US qt. (1.1 l)	

<sup>1</sup> Canada only.

### Fuels, coolants, lubricants, etc.

	Model	Capacity	Fuels, coolants, lubricants, etc.
<b>Power steering</b>	All models	0.85 US qt. (0.8 l)	MB Power Steering Fluid (Chevron Texaco PSF 9109) <sup>1</sup>
<b>Front wheel hubs</b>	All models	approx. 3.6 oz. (95 g) each	High-temperature roller bearing grease
<b>Brake system</b>	All models	approx. 0.53 US qt. (0.5 l)	MB Brake Fluid (DOT 4+)
<b>Cooling system</b>	All models	5.07 US qt. (4.8 l)	MB 325.0 Anticorrosion/Antifreeze
<b>Fuel tank including a reserve of</b>	All models	17.43 US gal (66.0 l) 2.11 US gal (8.0 l)	Premium unleaded gasoline: Minimum Posted Octane 91 (Avg. of 96 RON/86 MON)
			C 300 and C 300 Sport (with automatic transmission*), USA only: Flexible Fuel Vehicle (identified by a label reading <b>Premium gasoline or E85 only!</b> on fuel filler flap). Alternative fuel: Ethanol fuel (E85)
<b>Air conditioning system</b>	All models		R-134a refrigerant and special PAG lubricant oil (never R-12)

<sup>1</sup> For detailed information, please refer to the Factory Approved Service Products pamphlet (USA only) or contact an authorized Mercedes-Benz Center.

Fuels, coolants, lubricants, etc.

	Model	Capacity	Fuels, coolants, lubricants, etc.
Windshield washer	C 230 (all models) <sup>1</sup>	4.23 US qt (4.0 l)	MB Windshield Washer Concentrate <sup>2</sup>
	C 350 4MATIC <sup>1</sup>	4.23 US qt (4.0 l)	
	C 350 4MATIC Sport <sup>1</sup>	4.23 US qt (4.0 l)	
	C 300 (all models)	6.34 US qt (6.0 l)	
	C 350 <sup>1</sup>	6.34 US qt (6.0 l)	
	C 350 Sport	6.34 US qt (6.0 l)	

<sup>1</sup> Canada only.

<sup>2</sup> Use MB Windshield Washer Concentrate “MB SummerFit” and water for temperatures above freezing point or MB Windshield Washer Concentrate “MB SummerFit” and commercially available premixed windshield washer solvent/antifreeze for temperatures below freezing point. Follow suggested mixing ratios (> page 486).



### Fuels, coolants, lubricants, etc.

#### Engine oils

Engine oils are specifically tested for their suitability in our engines and durability for our service intervals. Therefore, only use approved engine oils and oil filters required for vehicles with Maintenance System.

For a listing of approved engine oils and oil filters, refer to the Factory Approved Service Products pamphlet (USA only), or contact an authorized Mercedes-Benz Center.

**!** *Using engine oils and oil filters of specification other than those expressly required for the Maintenance System, or changing of oil and oil filter at change intervals longer than those called for by the Maintenance System will result in engine or emission control system damage not covered by the Mercedes-Benz Limited Warranty.*

*Please follow Maintenance System recommendations for scheduled oil changes. Failure to do so will result in engine or emission control system damage not covered by the Mercedes-Benz Limited Warranty.*

#### Engine oil additives

Do not blend oil additives with engine oil. They may damage the engine.

Damage or malfunctions resulting from blending oil additives are not covered by the Mercedes-Benz Limited Warranty.

#### Air conditioning refrigerant

R-134a (HFC) refrigerant and special PAG lubricating oil are used in the air conditioning system.

Never use R-12 (CFC) or mineral-based lubricating oil. Otherwise damage to the system will occur.

#### Brake fluid

##### Warning!



During vehicle operation, the boiling point of the brake fluid is continuously reduced through the absorption of moisture from the atmosphere.

Under extremely strenuous operating conditions, this moisture content can lead to the formation of bubbles in the system, thus reducing the system's efficiency.

Therefore, the brake fluid must be replaced regularly. Refer to your vehicle's Maintenance Booklet for replacement interval.

Only brake fluid approved by Mercedes-Benz is recommended. An authorized Mercedes-Benz Center will provide you with additional information.

## Premium unleaded gasoline

### Warning!



Gasoline is highly flammable and poisonous. It burns violently and can cause serious personal injury.

Never allow sparks, flame or smoking materials near gasoline!

Turn off the engine before refueling.

Whenever you are around gasoline, avoid inhaling fumes and skin or clothing contact, extinguish all smoking materials.

Direct skin contact with fuels and the inhalation of fuel vapors can damage your health.

**!** *To maintain the engine's durability and performance, premium unleaded gasoline must be used. If premium unleaded gasoline is not available and low octane fuel is used, follow these precautions:*

- *Have the fuel tank only partially filled with unleaded regular gasoline and fill up with premium unleaded gasoline as soon as possible.*
- *Avoid full throttle driving and abrupt acceleration.*
- *Do not exceed an engine speed of 3 000 rpm if the vehicle is loaded with a light load such as two persons and no luggage.*
- *Do not exceed  $\frac{2}{3}$  of maximum accelerator pedal position if the vehicle is fully loaded or operating in mountainous terrain.*

## Gasoline additives

A major concern among engine manufacturers is carbon build-up caused by gasoline. Mercedes-Benz recommends only the use of quality gasoline containing additives that prevent the build-up of carbon deposits.

After an extended period of using fuels without such additives, carbon deposits can build up especially on the intake valves and in the combustion area, leading to engine performance problems such as:

- Warm-up hesitation
- Unstable idle
- Knocking/pinging
- Misfire
- Power loss

### Fuels, coolants, lubricants, etc.

In areas where carbon deposits may be encountered due to lack of availability of gasolines which contain these additives, Mercedes-Benz recommends the use of additives approved by us for use on Mercedes-Benz vehicles.

Refer to Factory Approved Service Products pamphlet (USA only), or contact an authorized Mercedes-Benz Center for a listing of approved product(s). Follow directions on product label.

Do not blend other fuel additives with fuel. This only results in unnecessary cost and may be harmful to the engine operation.

**!** *Damage or malfunction resulting from poor fuel quality or from blending additional fuel additives other than those tested and approved by us for use on Mercedes-Benz vehicles are not covered by the Mercedes-Benz Limited Warranty.*

*For a listing of approved products, refer to the Factory Approved Service Products pamphlet (USA only) or contact an authorized Mercedes-Benz Center.*

### Fuel requirements

Only use premium unleaded fuel:

- The octane number (posted at the pump) must be 91 min. It is an average of both the Research Octane Number (RON) and the Motor Octane Number (MON):  $(RON+MON)/2$ . This is also known as the ANTI-KNOCK INDEX.

Unleaded gasoline containing oxygenates such as ethanol, IPA, IBA and TBA can be used provided the ratio of any one of these oxygenates to gasoline does not exceed 10%; MTBE must not exceed 15%.

The ratio of methanol to gasoline must not exceed 3% plus additional co-solvents.

Using mixtures of ethanol and methanol is not allowed. Gasohol, which contains 10% ethanol and 90% unleaded gasoline, can be used.

These blends must also meet all other fuel requirements, such as resistance to spark knock, boiling range, vapor pressure, etc.

### Flexible Fuel Vehicles (USA only)

C 300 and C 300 Sport (with automatic transmission\*) are Flexible Fuel Vehicles.

Flexible Fuel Vehicles are identified by a label reading **Premium gasoline or E85 only!** on fuel filler flap).

These vehicles are designed to operate on premium unleaded gasoline or Ethanol fuel (E85), or on any mixture of these two. Ethanol fuel (E85) is a mixture of approximately 85% Ethanol and 15% unleaded gasoline.

### Warning!



Ethanol fuel (E85) and its fumes are highly flammable, poisonous and burn easily. Ethanol fuel can cause serious injuries if ignited or if you come into contact with it or inhale fumes of it. Avoid inhalation of Ethanol fumes and skin contact with Ethanol. Extinguish all open flames before fueling. Never smoke or create sparks close to Ethanol.

**Fuels, coolants, lubricants, etc.****Switching fuels**

For best performance and driveability it is recommended to use either one or the other fuel. A refueling pattern that alternates between the two different fuels should be avoided if possible.

When switching fuels, make sure:

- Fuel level is below half full.
- Fuel level is above reserve (reserve warning lamp is not lit).
- Amount of added fuel is more than 5 gallons (20 liters).
- Ignition is off during refill.
- Immediately after refueling engine is started and operated for at least five minutes.

These precautions and recommendations are supposed to prevent any difficulties when starting and operating the engine which otherwise may be experienced before the engine has fully adapted to the different fuel.

If in spite of these recommendations the engine does not perform properly, adding more gasoline (at least 3 gallons [12 liters]) to the fuel may improve the engine behavior.

**Cruising range**

E85 fuel contains less energy per gallon than gasoline. To ensure that engine performance with Ethanol fuel is similar to that when using gasoline, the engine must burn more Ethanol fuel. As a result, it is to be expected that the fuel consumption will increase when using E85 compared to gasoline operation.

 *Use of E85 may reduce your driving range.*

**Maintenance**

Please inform your authorized Mercedes-Benz Center if you use or have used E85 fuel when your vehicle is delivered for maintenance or repairs.

**Cold weather performance**

It is possible that starting times will significantly increase at temperatures below 32°F (0°C). At low temperatures the use of a block heater is recommended (see an authorized Mercedes-Benz Center for further information). Rough idling may also be experienced at such temperatures before the engine is fully warmed up.

 *E85 fuel is unsuitable for use when ambient temperatures fall below 14°F (-10°C).*

**Hot weather performance**

At ambient temperatures above 95°F (35°C) start times may increase and be accompanied by a rough idle following the start.

### Fuels, coolants, lubricants, etc.

#### Coolants

The engine coolant is a mixture of water and anticorrosion/antifreeze, which provides:

- Corrosion protection
- Freeze protection
- Boiling protection (by increasing the boiling point)

The cooling system was filled at the factory with a coolant providing freeze protection to approximately  $-22^{\circ}\text{F}$  ( $-30^{\circ}\text{C}$ ) and corrosion protection.

**!** *Add premixed coolant solution only. Adding water and MB 325.0 Anticorrosion/Antifreeze separately from each other, could cause engine damage not covered by the Mercedes-Benz Limited Warranty.*

If the antifreeze mixture is effective to  $-22^{\circ}\text{F}$  ( $-30^{\circ}\text{C}$ ), the boiling point of the coolant in the pressurized cooling system is reached at approximately  $266^{\circ}\text{F}$  ( $130^{\circ}\text{C}$ ).

The coolant solution must be used year round to provide the necessary corrosion protection and increase boil-over protection. Refer to Maintenance Booklet for replacement interval.

Coolant system design and coolant used determine the replacement interval. The replacement interval published in the Maintenance Booklet is only applicable if MB 325.0 Anticorrosion/Antifreeze solution or other Mercedes-Benz approved products of equal specification are used to renew the coolant concentration or bring it back up to the proper level.

For information on other Mercedes-Benz approved products of equal specification, refer to the Factory Approved Service Products pamphlet (USA only) or contact an authorized Mercedes-Benz Center.

To provide important corrosion protection, the solution must be at least 50% anticorrosion/antifreeze (equivalent to freeze protection to approximately  $-35^{\circ}\text{F}$  [ $-37^{\circ}\text{C}$ ]).

If you use a solution that is more than 55% anticorrosion/antifreeze (freeze protection to approximately  $-49^{\circ}\text{F}$  [ $-45^{\circ}\text{C}$ ]), the engine temperature will increase due to the lower heat transfer capability of the solution. Therefore, do not use more than this amount of anticorrosion/ antifreeze.

If the coolant level is low, water and MB 325.0 Anticorrosion/Antifreeze should be used to bring it up to the proper level (have cooling system checked for signs of leakage).

The water in the cooling system must meet minimum requirements, which are usually satisfied by normal drinking water. If you are not sure about the water quality, consult an authorized Mercedes-Benz Center.

**Fuels, coolants, lubricants, etc.**

**Anticorrosion/antifreeze**

Your vehicle contains a number of aluminum parts. The use of aluminum components in motor vehicle engines necessitates that anticorrosion/antifreeze coolant used in such engines be specifically formulated to protect the aluminum

parts. Failure to use such anticorrosion/antifreeze coolant will result in a significantly shortened service life.

Therefore, the following product is strongly recommended for use in your vehicle: Mercedes-Benz 325.0 Anticorrosion/Antifreeze agent.

Before the start of the winter season (or once a year in hot southern regions), you should have the anticorrosion/antifreeze concentration checked. The coolant is also regularly checked each time you bring your vehicle to an authorized Mercedes-Benz Center for service.

***Anticorrosion/antifreeze quantity***

Model	Approx. freeze protection	
	- 35°F (- 37°C)	- 49°F (- 45°C)
C 300	2.54 US qt. (2.4 l)	2.79 US qt. (2.64 l)
C 350	2.54 US qt. (2.4 l)	2.79 US qt. (2.64 l)

### Fuels, coolants, lubricants, etc.

#### Windshield washer system and headlamp cleaning system\*

Both the windshield washer system and headlamp cleaning systems are supplied from the windshield washer fluid reservoir.

The windshield washer reservoir has a capacity of approximately 6.34 US qt (6.0 l).

- ▶ Refill the reservoir with MB Windshield Washer Concentrate “MB SummerFit” and water (or concentrate and commercially available premixed windshield washer solvent / antifreeze, depending on ambient temperatures).

#### Warning!



Washer solvent/antifreeze is highly flammable. Do not spill washer solvent/antifreeze on hot engine parts, because it may ignite and burn. You could be seriously burned.

#### Windshield and headlamp washer fluid mixing ratio

For temperatures above freezing point, use MB Windshield Washer Concentrate “MB SummerFit” and water:

- 1 part “MB SummerFit” to 100 parts water  
(1.34 fl oz [40 ml] “MB SummerFit” to 1 gal [4.0 l] water).

For temperatures below freezing point, use MB Windshield Washer Concentrate “MB SummerFit” and commercially available premixed windshield washer solvent/antifreeze:

- 1 part “MB SummerFit” to 100 parts solvent  
(1.34 fl oz [40 ml] “MB SummerFit” to 1 gal [4.0 l] solvent).

**A**

- ABS 27, 59
  - Indicator lamp 59, 374
  - Messages in display 389, 398
- Accelerator position, automatic transmission 142
- Accessory weight 356
- Accident 132
- Air bags 36
  - Children 51
  - Front 39
  - Front passenger front air bag off indicator lamp 29, 45
  - OCS 41
  - Safety guidelines 38
  - Side impact 40
  - Window curtain 40, 41
- Air conditioning system see Climate control system
- Air conditioning, Cooling 258, 267
- Air conditioning, Refrigerant 478, 480
- Air distribution 254, 263
- Air pressure see Tire inflation pressure
- Air recirculation mode 257, 265
- Air vents 247
  - Center air vents 248
  - Rear center console air vents 249
- Air volume 254, 263, 268
- Alarm
  - Audible alarm and flashing exterior lamps (Panic alarm) 58
- Alarm system see Anti-theft systems
- Antiglare
  - Rear view mirrors 100
- Anti-theft systems 66
  - Alarm, visual and audible 66
  - Anti-theft alarm system 66
  - Immobilizer 66
- Aquaplaning see Hydroplaning
- Armrest 284, 286
- Ashtrays 291, 292
- Aspect ratio 356
- Audio Aux mode 220
- AUDIO menu (Control system) 158
- Audio system 176
  - “911” emergency call 231
  - Audio and telephone, operation 176
  - Audio Aux mode 220
  - Audio control unit 177
  - Audio display 180
  - Bluetooth® operation 222
  - Call lists 236
  - CD changer\* 208, 214
  - CD operation 208
  - CD player 160, 208
  - CD, fast forward/rewind 219
  - CD, pause function 218
  - CD, submenu overview 208
  - Components 177
  - Controller 182
  - Example, how to use 187
  - Functions during a single call 240
  - Making calls 237
  - On/Off 188
  - Operating 185
  - Operating and display elements 178
  - Operating CD player 213
  - Operating safety 177
  - Operation 188
  - Overview 176



- Phone cook 233
  - Radio operation 194
  - Satellite radio\* operation 200
  - Sound settings 189
  - Surround sound\* (Canada only) 190
  - SYS menu 192
  - SYS menu, Bluetooth® settings 192
  - SYS menu, display settings 192
  - SYS menu, language settings 193
  - SYS menu, reset to factory settings 193
  - Telephone menu\* 222
  - Volume 189
  - Auto-dimming\*, Rear view mirrors 100
  - Automatic central locking 80
    - Activating/deactivating (Control system) 173
  - Automatic climate control (3-zone) see Climate control system
  - Automatic headlamp mode 109, 172
  - Automatic lighting control, Interior lighting 115
  - Automatic shift program 144
  - Automatic transmission
    - Accelerator position 142
    - Emergency operation (limp-home mode) 146
    - Fluid 476, 477
    - Fluid level 328
    - Gear ranges 143
    - Gear shifting malfunctions 146
    - Hill start assist system 246
    - Kickdown 142
    - Shifting procedure 139
    - Starting the engine 127
    - Transmission fluid 328
  - Automatic transmission\*
    - Automatic shift program 144
    - Gear selector lever 138
    - Gear selector lever control one-touch gearshifting 145
    - Gear selector lever positions 140
    - Program mode selector switch 144
  - Aux socket 220
- B**
- Backrest 281
  - Backup lamps
    - Replacing bulbs 430, 431
  - Bar 356
  - BAS 60
  - Batteries, SmartKey
    - Checking battery condition 78
    - Replacing 428
  - Batteries, SmartKey with KEYLESS-GO\* (Canada only)
    - Checking battery condition 78
    - Replacing 428
  - Battery 448
  - Battery, vehicle 446
    - Charging 449
    - Discharged, Jump starting 451
    - Disconnecting 448
    - Message in display 399
    - Reconnecting 450
    - Removing 449
  - Bead 356
  - Beverage holder see Cup holder

## Bluetooth®

- Settings (Audio system) 192
- Telephone\* (Audio system) 222
- Brake assist system (BAS) 60
- Brake fluid 324, 478, 480
- Brake lamp
  - High mounted 431
  - Replacing bulbs 431, 436
- Brake pads
  - Message in display 399
- Brake warning lamp 27
- Brakes 312
  - Warning lamp 27, 376
- Break-in period 310
- Bulbs, replacing see Replacing bulbs

**C**

- California retail buyers and lessees, important notice for 11
- Can holder see Cup holder
- Capacities and recommended fuel/lubricants 476
- Cargo area see Trunk
- Carpets, Cleaning and care of 371
- Catalytic converter 319
- CD
  - CD changer\* 208
  - CD player 160, 208
  - MP3 playback options 220
  - MP3, selecting a track 219
  - Playback options 220
  - Selecting a track 219
  - Submenu overview 208
- CD changer\* 208
- CD player 160, 208
- Centigrade see Temperature display
  - mode 167
- Central locking
  - Automatic 80, 173
  - Locking/unlocking from inside 81
  - Locking/unlocking switches 81
- Central locking/unlocking switches 80

- Certification label 462
- Change of address or ownership 12
- Checking tire pressure electronically
  - Tire Pressure Monitoring System (TPMS), (USA only) 344
- Children in the vehicle 51
  - Air bags 51
  - Front passenger front air bag off indicator lamp 45, 385
  - Infant and child restraint systems 51
  - LATCH-type child seat anchors 55
  - Override switch for rear door window operation 57
  - Tether attachment points 54
- Cigarette lighter 292
- Climate control system 250, 259
  - 3-zone automatic climate control (Canada only) 259
  - Air conditioning, Cooling 258, 267
  - Air distribution 254, 263
  - Air recirculation mode 257, 265
  - Air volume 254, 263
  - Air volume, rear 268
  - Automatic mode 253
  - Deactivating/Reactivating 252
  - Defrosting 264

- Dual-zone automatic climate control 250
- Front defroster 255
- Rear climate control 268
- Rear window defroster 256, 265
- Residual engine heat and ventilation 266
- Setting the temperature 262
- Temperature 253
- Windshield, defogging 255
- Clock 151
  - Setting time 170
- Cockpit 24
- Cold weather performance 483
- COMAND\* see separate COMAND operating instructions
- Combination switch 112
  - Corner-illuminating front fog lamps\* 112
  - High beam flasher 112
  - Turn signals 131
  - Windshield wipers 117
- Control system 151
  - Multifunction display 151
  - Multifunction steering wheel 152
  - Resetting to factory default 165
- Control system menu 151
  - AUDIO 158
  - Menus overview 154
  - Navi\* 158
  - Service menu 164
  - Settings menu 165
  - Standard display 156
  - TEL\* 160
  - Trip computer 156
  - Vehicle status message memory 164
- Control system submenus 153, 155
  - Convenience 174
  - Instrument cluster 168
  - Lighting 171
  - Time/Date 170
  - Vehicle 173
- Coolant 329
  - Adding 329
  - Anticorrosion/antifreeze mixing ratio and quantity 484
  - Checking level 329
  - Messages in display 405
  - Temperature 321
  - Temperature gauge 27, 148
- Coolant level
  - Checking 329
- Corner-illuminating front fog lamps\* 112
  - Replacing bulbs 431
- Cruise control 241
  - Activating 242
  - Canceling 243
  - Driving downhill 243
  - Driving uphill 243
  - Setting current speed 242
  - Setting to last stored speed (“Resume” function) 245
- Cruising range, fuel 483
- Cup holder
  - In front seat armrest 287
  - In rear seat armrest 287
- Curb weight 356

**D**

- Date display, setting 170
- Daytime running lamp mode 110
  - Setting 171
- Deep water see Standing water
- Defogging
  - Windshield 255
- Defrosting 264
- Defrosting, Front 255
- Delayed shut-off
  - Interior lighting 173
- Department of Transportation see DOT
- Difficulties
  - While driving 132
  - While starting 129
- Digital clock see clock
- Digital speedometer 158
  - Additional speedometer 169, 170
  - Permanent display 169
- Dimensions, Vehicle 474
- Direction of rotation, Tires 334
- Displays
  - Additional speedometer 169, 170
  - Digital speedometer 158
  - Maintenance service indicator 362
  - Multifunction display 151
  - Outside temperature 158
  - Permanent display 169
  - Vehicle status message see Multifunction display messages
  - Vehicle status messages
    - memory 165
- Distance to empty (range), Trip computer 157
- Document holder 289
- Door
  - Control panel 32
  - Entry lamps 116
  - Inside door handle 79
  - Locking 72, 77
  - Locking with Tele Aid\* 302
  - Messages in display 406
  - Opening from inside vehicle 79
  - Opening from outside 72, 77
  - Unlocking 71, 76
  - Unlocking with Tele Aid\* 301
- DOT 357
- Downhill driving
  - Cruise control 243
- Drink holder see Cup holder
- Drinking and driving 311
- Driving 126
  - Abroad 318
  - Hydroplaning 315
  - In winter 317
  - Instructions 126, 311
  - Problems 132
  - Safety systems 59
  - Through standing water 318
- Driving off 314
- Driving safety systems
  - 4MATIC 65
  - ABS 59
  - BAS 60
  - EBP 61
  - Electronic traction system 63
  - ESP® 62
- Driving systems 241
  - Cruise control 241
  - Driving safety systems 59
- Driving tips 142
  - Accelerator position 142
  - Kickdown 142

- Dual-zone automatic climate control
  - Maximum cooling MAX COOL 256
- Dual-zone automatic climate control see Climate control system
- E**
- Easy-entry/exit feature\*
  - (Canada only) 95, 174
- EBP 61
- Electrical fuses see Fuses
- Electrical outlet
  - Glove box 293
  - Rear passenger compartment 293
- Electrical system, Technical Data 473
- Electronic Brake Proportioning see EBP
- Electronic Stability Program see ESP®
- Electronic traction system 63
- Emergency call system 295
- Emergency calls, Tele Aid\* 296
- Emergency operation (Limp-Home Mode) 146
- Emergency operations
  - Gear selector lever\*, Unlocking 426
  - Locking the vehicle 424
  - Releasing from inside 271
  - Remote door lock\* 302
  - Remote door unlock\* 301
  - Unlocking the trunk 425
  - Unlocking the vehicle 424
- Emergency tensioning device see ETD
- Emergency, In case of
  - Battery, Jump starting 451
  - First aid kit 420
  - Flat tire 440
  - Fuses 456
  - Instrument cluster, Indicator lamps 374–383
  - Roadside Assistance 12
  - Roadside Assistance\* (Tele Aid\*) 299
  - Towing the vehicle 453
- Emission control 320
- Emission control information label 463
- Emission control system warranties 10
- Engine
  - Adding engine oil 328
  - Belt layout 464
  - Cleaning 366
  - Compartment 325
  - Coolant 329, 478, 484
  - Malfunction indicator lamp 27, 378
  - Number 462, 463
  - Oil 327, 476, 480
  - Residual heat and ventilation 266
  - Starting 127
  - Technical data 465
  - Turning off 134
- Engine coolant see Coolant
- Engine oil 327
  - Adding 328
  - Additives 480
  - Checking level (Dipstick) 327
  - Consumption 327
  - Dipstick 327
  - Filler neck 327, 328
  - Recommended engine oils and oil filters 476

- ESP<sup>®</sup> 62
  - Four wheel electronic traction system with ESP<sup>®</sup> 65
  - Messages in display 389, 397, 398
  - Warning lamp 27, 376, 379, 380
- ETD 49
  - Safety guidelines 38
- Ethanol fuel
  - At the gas station 322
  - Switching fuels 483
- Exterior rear view mirrors
  - Adjusting 97
  - Auto-dimming on the driver's side 99, 100
  - Fold-in settings 175
  - Power folding\* 98
- F**
  - Fahrenheit see Temperature display mode 167
  - First aid kit 420
  - Flat tire 440
    - Lowering the vehicle 445
    - Mounting the Minispare wheel 441
    - Preparing the vehicle 440
  - Flexible fuel vehicles 482
    - At the gas station 322
    - Switching fuels 483
  - Floormats\* 294
  - Fluids
    - Automatic transmission fluid 476, 477
    - Brake fluid 478, 480
    - Capacities 476
    - Engine coolant 329, 478, 484
    - Engine oil 328, 476, 480
    - Power steering fluid 478
    - Windshield washer and headlamp cleaning system 479, 486
  - Fog lamps 431
    - Messages in display 410
    - Replacing bulbs 431, 432, 436
  - Four wheel electronic traction system (4MATIC) with ESP<sup>®</sup> 65
  - 4MATIC 65
  - Front air bags 39
  - Front lamps see headlamps
  - Front passenger front air bag 39
    - Messages in display 393
  - Front passenger front air bag off indicator lamp 29, 45, 385
  - Front seats
    - Heating\* 91
  - Fuel 322, 478, 481
    - Additives 481
    - Capacity, Fuel tank 478
    - Cruising range 483
    - E85 (Ethanol fuel) 478, 483
    - Filling the tank 322
    - Fuel filler flap and cap 322
    - Fuel reserve warning lamp 27, 150, 380
    - Gauge 27, 150
    - Premium unleaded gasoline 478, 481
    - Requirements, Octane rating 482
    - Switching (Flexible fuel vehicle) 483

- Fuel cap
  - Message in display 406
- Fuel consumption statistics
  - From start 156
  - Resetting 157
  - Since last reset 157
- Fuel filler flap 322
  - Locking/Unlocking 322
- Fuel tank
  - Capacity 478
  - Filler flap 322
- Fuels, coolants, lubricants etc.
  - Capacities 476
- Fuses 456
  - Fuse box in engine compartment 457
  - Fuse box in passenger compartment 457
  - Fuse box in trunk 458
  - Replacing 456
- G**
  - Garage door opener 303
  - Gasoline also see Fuel
  - GAWR 357
  - Gear range
    - Automatic transmission 143
    - Limiting 143
    - Shifting into optimal 145
  - Gear selector lever 126, 137
    - Messages in display 392
    - Position, Automatic
      - transmission\* 139, 151
    - Shifting procedure 139
  - Gear selector lever one-touch gearshifting
    - Automatic transmission\* 145
  - Gear selector lever\* 138
    - Gearshift pattern 138
    - Lock 127
    - Position, Automatic
      - transmission\* 140
    - Unlocking in an emergency 426
  - Glove box 284
    - Aux socket 220
    - Power outlet 293
  - Gloves, Vehicle tool kit 420
- GPS
  - Tele Aid\* 295
- Gross Axle Weight Rating see GAWR
- Gross Vehicle Weight Rating see GVWR
- Gross Vehicle Weight see GVW
- GVW 357
- GVWR 357

**H**

- Halogen headlamp see Headlamps
- Hands-free microphone 31
- Hard plastic trim items, cleaning 370
- Hazard warning flasher 114
- Head restraints 89
  - Active head restraints 50
  - Adjustment 89
  - Front seat 89
  - Rear seat, Removing and installing 90
  - Resetting activated active head restraints 427
- Headlamp cleaning system 112, 330
  - Washer fluid 479, 486
- Headlamps
  - Automatic control 109
  - Automatic headlamp mode 172
  - Cleaning lenses 367
  - Cleaning system 330
  - Halogen 432
  - Manual headlamp mode 172
  - Messages in display 411
  - Refilling washer fluid 330
  - Replacing bulbs 431, 432

- Headliner and shelf below rear window,
  - Cleaning and care of 371
- High beam flasher 112
  - Replacing bulbs (Bi-Xenon\*) 431, 435
  - Replacing bulbs (Halogen) 431, 433
- High beam headlamps
  - Indicator lamp 27
  - Replacing bulbs (Bi-Xenon\*) 431
  - Replacing bulbs (Halogen) 431, 433
  - Replacing bulbs for high beam flasher (Bi-Xenon\*) 435
- High mounted brake lamp 431
- Hood 325
  - Message in display 406
  - Opening 325
- Horn 25
- Hot weather performance 483
- HVAC see Climate control system
- Hydroplaning 315

**I**

- Identification labels 462
- Identification Number, Vehicle (VIN) 463
- Ignition 82, 84, 127
  - Switching on 82
  - Switching on, KEYLESS-GO\* 84
- Immobilizer 66
- Infant and child restraint systems see Children in the vehicle
- Inside door handle 79
- Instrument cluster 26, 147
  - Coolant temperature gauge 27, 148
  - Fuel gauge 27, 150
  - Illumination 148
  - Lamps 374
  - Multifunction display 151
  - Outside temperature indicator 149
  - Setting the language (Audio system) 193
- Interior lighting 114
  - Activating automatic control 115
  - Deactivating automatic control 115
  - Delayed shut-off 173
  - In the rear 116
  - Reading lamps in the front 115, 116
  - Reading lamps in the rear 116



Interior rear view mirror  
  Adjusting 97  
  Auto-dimming 99, 100  
Interior storage spaces see  
  Storage compartments

## J

Jack 421  
Jump starting 451

## K

Key, Mechanical 424  
  Loss of 79  
Key, SmartKey 70  
  Battery check lamp 70, 72  
  Factory setting 71  
  Global locking and unlocking 71  
  Lock button 70  
  Locking and unlocking 70  
  Loss of 79  
  Messages in display 408  
  Opening button for trunk 70  
  Panic button 58  
  Remote control 70  
  Restoring to factory setting 73  
  Selective setting 72  
  Starting the engine 127  
  Steering wheel lock 82  
  Switching on ignition with 82  
  Turning off engine 135  
  Unlock button 70

Key, SmartKey with KEYLESS-GO\* 73  
  Battery check lamp 73, 77  
  Closing, Trunk 269  
  Factory setting 76  
  Global locking and unlocking 77  
  Important notes on using  
    KEYLESS-GO\* 75  
  Locking and unlocking 73  
  Opening button for trunk 73  
  Panic button 58  
  Restoring to factory setting 78  
  Selective setting 77  
  Starting the engine 128  
  Switching on ignition with 84  
  Unlock button 73  
Key, SmartKey with KEYLESS-GO\*  
  (Canada only)  
  Lock button 73  
  Loss of 79  
  Messages in display 407  
  Remote control 73  
  Turning off engine 135  
Kickdown 142  
Kilopascal 357

- L**
- Labels 462
    - Certification 462
    - Emission control information 463
    - Tire and Loading Information 335
  - Lamps, exterior 431
    - Light sensor 409
  - Lamps, indicator and warning
    - ABS 27, 59, 374
    - Air bag Off 40
    - Battery check lamp (SmartKey with KEYLESS-GO\* 77
    - Battery check lamp (SmartKey) 72
    - Brake warning lamp 27
    - Brakes 376
    - Engine diagnostics 27, 378
    - Engine malfunction 27, 378
    - ESP® 27, 376, 379, 380
    - Front passenger front air bag off 29, 45, 385, 386
    - Fuel reserve 380
    - High beam headlamps 27
    - Instrument cluster 374–383
    - Maintenance service indicator 362
    - Seat belt telltale 27, 380
    - SRS 27, 382
    - Turn signals 27
  - Language 193
  - Language, Setting 168
  - LATCH-type child seat anchors see Children in the vehicle
  - Lever
    - For cruise control 242
  - License plate lamps
    - Messages in display 411
    - Replacing bulbs 431, 437
  - Light alloy wheels, Cleaning 370
  - Light sensor
    - Message in display 409
  - Lighter see Cigarette lighter
  - Lighting 108
    - Automatic headlamp mode 109
    - Corner-illuminating front fog lamps\* 112
    - Daytime running lamp mode 110
    - Door entry lamps 116
    - High beam flasher 112
    - Instrument cluster illumination 148
    - Interior 114
    - Manual headlamp mode 108
    - Trunk 116
  - Limp-home mode 146
  - Loading see Vehicle loading
  - Locator lighting 172
  - Lock button
    - Door handle (KEYLESS-GO\*, Canada only) 76, 125
    - Key, SmartKey 70
    - Key, SmartKey with KEYLESS-GO\* (Canada only) 73
  - Locking 133
    - Vehicle in an emergency 425
  - Locking knob 79
  - Loss of
    - Key, Mechanical 79
    - Key, SmartKey 79
    - Key, SmartKey with KEYLESS-GO\* (Canada only) 79
    - Service and Warranty Information Booklet 461
  - Low beam headlamps
    - Replacing bulbs (Bi-Xenon\*) 431
    - Replacing bulbs (Halogen) 431, 433
  - Lowering
    - Vehicle 445
  - Lubricants 476
  - Lumbar support\* 91

**M**

- Maintenance 11, 362
  - Automatic Call (Tele Aid\*) 302
  - Calling up service indicator display 363
  - Clearing service indicator message 362
  - Maintenance System 362
  - Resetting service indicator 363
  - Service indicator message 362
  - Service term exceeded 363
  - Vehicles with E85 fuel 483
- Manual headlamp mode 108
- Manual transmission 136, 137
  - Gearshift lever 126, 137
  - Shift positions 137
  - Starting the engine 127
- Maximum load rating, Tires 357
- Maximum loaded
  - vehicle weight 340, 357
- Maximum tire
  - inflation pressure 354, 357
- Maximum tire load rating 353
- Memory function\* (Canada only) 102
- Menus see Control system
- Messages in display see
  - Multifunction display messages
- Microphone, Hands-free 31
- Minispare wheel 422, 471
  - Mounting 441
- Mirrors
  - Activating exterior rear view mirror parking position\* (Canada only) 101
  - Adjusting 97
  - Auto-dimming\* for rear view mirrors 100
  - Exterior rear view mirrors 97
  - Interior rear view mirror 97
- Modifications and alterations,
  - Operating safety 15
- MON 478
- MP3
  - Playback options 220
  - Selecting a folder 219
  - Selecting a track 219
- Multifunction display 151
  - Changing settings see Control system menus and Control system sub-menus
- Multifunction display messages
  - ABS 389, 398
  - Battery, vehicle 399
  - Brake fluid 400
  - Brake pads 399
  - Coolant 402
  - Coolant level 405
  - Doors 406
  - EBP (Electronic Brake Proportioning) 401
  - ESP® 389, 397, 398
  - Fog lamps 410
  - Front passenger front air bag 393
  - Fuel cap 406
  - Gear selector lever 392
  - Headlamps 411
  - Hood 406
  - Key, SmartKey 408
  - Key, SmartKey with KEYLESS-GO\* (Canada only) 407
  - Lamps, exterior 409
  - License plate lamps 411
  - Light sensor 409
  - Low tire pressure 418
  - Parking brake 401
  - Parking lamps 411

Restraint systems 416  
 Run Flat Indicator 390  
 Side marker lamps 412  
 SRS 416  
 Tele Aid\* 418  
 TPMS\* (Tire Pressure Monitoring System), (USA only) 392, 418  
 Trunk 419  
 Turn signals 413  
 Windshield washer fluid 419  
 Multifunction steering wheel 28, 152  
   Button operation 152

**N**

Navigation system\* 158  
   See separate COMAND\* operating instructions  
 Neutral gear position,  
   Automatic transmission\* 138, 140  
 Neutral gear position,  
   Manual transmission 137  
 New vehicle break-in 310  
 Normal occupant weight 357  
 Number, Vehicle Identification (VIN) 463

**O**

Occupant Classification System see OCS  
 Occupant distribution 357  
 Occupant safety 34  
   Air bags 36  
   Children and air bags 51  
   Children in the vehicle 51  
   Fastening the seat belt 105  
   Front passenger front air bag off indicator lamp 45  
   Infant and child restraint systems 51  
   LATCH-type child seat anchors 55  
   Seat belts 38, 105

OCS 41  
   Self-test 45

Oil  
   Filler neck 328

One-touch gearshifting  
   Gear selector lever\* 145

Operating safety 15

Operating safety (Audio system) 177

Ornamental moldings, Cleaning 367

Outside temperature indicator 27, 149

Outside temperature see Displays

Overhead control panel 31

Override switch 57

**P**

Paintwork, Cleaning 365  
 Panic alarm  
   Audible alarm and flashing exterior lamps 58  
   Panic button 58  
 Panorama roof with power tilt/sliding panel\* 276  
   Cleaning 369  
   Opening/closing 277  
   Synchronizing 278  
 Parcel net in front passenger footwell 285  
 Parking 133, 314  
 Parking brake 129, 134  
   Message in display 401  
 Parking lamps  
   Messages in display 411  
   Replacing bulbs 431, 434, 436  
 Parking position\* (Canada only)  
   Exterior rear view mirrors 101  
 Parts service 460  
 PASS AIR BAG OFF indicator lamp see Front passenger front air bag off indicator lamp

- Passenger compartment 318
    - Electrical outlet, glove box 293
    - Electrical outlet, rear seat ashtray 293
  - Passenger safety see Occupant safety
  - Pedals 311
  - Performance
    - Cold weather 483
    - Hot weather 483
  - Phone\* see Telephone\*
  - Plastic parts, cleaning 370
  - Poly-V-belt drive 464
    - Layout 464
  - Potential problems associated with under-inflated and overinflated tires 347
  - Power assistance 311
  - Power folding exterior rear view mirrors\* 98
  - Power tilt/sliding sunroof 273
    - Opening/closing 273
    - Synchronizing 275
  - Power washer 365
  - Power windows 120
    - Blocking of rear window operation 57
    - Cleaning 368
    - Opening/closing 120
  - Practical hints 420
  - Premium unleaded gasoline 478, 481
  - Problems
    - While driving 132
    - With vehicle 16
  - Product information 9
  - Production options weight 357
  - Program mode 151
  - Program mode see Automatic transmission\*, Automatic shift program
  - Program mode selector switch\*
    - Automatic shift program 144
  - Proper use of the vehicle 15
  - PSI 358
  - Push-start see Tow-start
- R**
- Radio
    - Operation 188, 189, 192, 193, 194, 222
    - Satellite radio\*, operation 200
    - Selecting stations (Control system) 159
  - Radio transmitters, control and operation 319
  - Range (distance to empty) 157
  - Reading lamps in the front 115, 116
  - Reading lamps in the rear 116
  - Rear bench seat, foldable\* 281
  - Rear climate control 268
  - Rear door window
    - Blocking operation 57
  - Rear fog lamp see Fog lamps
  - Rear lamps see Tail lamps
  - Rear seat ashtray see Ashtray
  - Rear seats
    - Adjustment 85
    - Head restraints 89
  - Rear view mirrors see Mirrors
  - Rear window defroster 256, 265
  - Recommended inflation pressure 358
  - Recovery services, Stolen vehicle (Tele Aid\*) 302
  - Refrigerant, Air conditioning 478, 480
  - Refueling 322
  - Regular checks 324
  - Remote
    - Door lock with Tele Aid\* 302
    - Door unlock with Tele Aid\* 301
    - Trunk opening/closing\* switch 269
  - Remote control, SmartKey 70
  - Remote control, SmartKey with KEYLESS-GO\* (Canada only) 73

- Replacing bulbs 430
    - Additional turn signals 431
    - Backup lamps 431, 436
    - Brake lamps 431
    - Corner-illuminating front fog lamp\* 431
    - Fog lamps 431, 436
    - Headlamp bulbs 432
    - Headlamps 431
    - High beam flasher (Bi-Xenon\*) 431, 435
    - High beam flasher (Halogen) 431, 433
    - High beam headlamps (Bi-Xenon\*) 431
    - High beam headlamps (Halogen) 431, 433
    - High mounted brake lamp 431
    - License plate lamps 431, 437
    - Low beam headlamps (Bi-Xenon\*) 431
    - Low beam headlamps (Halogen) 431, 433
    - Parking lamps 431, 434, 436
    - Side marker lamps 431
    - Standing lamps 431, 434, 436
    - Tail lamps 431, 436
    - Turn signal lamps 431
    - Turn signal lamps (Bi-Xenon\*) 436
    - Turn signal lamps (Halogen) 434
  - Reporting safety defects 17
  - Reset to factory settings (Audio system) 193
  - Residual engine heat and ventilation 266
  - Restraint systems
    - Messages in display 416
    - See Children in the vehicle
    - See SRS
  - Reverse gear position, Automatic transmission\* 138, 140
  - Reverse gear position, Manual transmission 126
  - Rims 358
    - And Tires 467
    - Tires and wheels 331
  - Roadside Assistance 12
  - Roadside Assistance\*
    - Tele Aid\* 299
  - RON 478
  - Roof rack\* 280
  - Rubber parts, cleaning 370
  - Run Flat Indicator\* (Canada only) 342
- S**
- Safety
    - Driving safety systems 59
    - Occupant 34
    - Reporting defects 17
  - Safety belts see Seat belts
  - Satellite radio\*
    - Calling SIRIUS Service Center 207
    - Channel update 207
    - Operation 200
    - Selecting program category 203
    - Showing program info 206
    - Storing channels 206
    - Submenu overview 200
    - Tuning in channels 204
  - Seat belts 46
    - Children in the vehicle 51
    - Cleaning 371
    - Fastening 46, 105
    - Force limiter 49
    - Messages in display 416
    - Proper use of 47, 106
    - Safety guidelines 38
    - Telltale 27, 48, 380
  - Seating capacity 335

- Seats 85
  - Adjustment 85
  - Easy entry/exit feature\* (Canada only) 95
  - Head restraints 89
  - Heating\*, front seats 91
  - Lumbar support 91
  - Memory function\* (Canada only) 102
  - Split rear bench seat\* 281
- Selector lever see Gear selector lever\*
- Self-test
  - OCS 45
  - Tele Aid\* 296
- Service and warranty information 10
- Service intervals see Maintenance service indicator
- Service life, Tires 332
- Service menu 164
- Service see Maintenance
- Service system see Maintenance, Maintenance System
- Service, Parts 460
- Setting
  - Cruise control 242
  - Higher speed in cruise control 244
  - Lower speed in cruise control 245
  - Temperature (interior) 262
  - To last stored speed (“Resume” function) in cruise control 245
- Setting current speed 242
- Settings
  - Control system menus and submenus 154, 155
  - Date 170
  - Daytime running lamp mode 171
  - Individual, Vehicle 165
  - Lighting (control system) 171
  - Menus and submenus 153
  - Resetting all (control system) 166
  - Resetting values in trip menu 157
- Shelf below rear window, Cleaning and care of 371
- Shift lever position indicator 151
- Shift program mode,
  - Automatic transmission\* 144, 151
- Shifting
  - Into reverse (manual transmission) 137
  - Manual transmission 126, 137
- Shifting, Automatic transmission\* 138
- Side impact air bags 40
- Side marker lamps
  - Cleaning lenses 367
  - Messages in display 412
  - Replacing bulbs 431
- Side windows see Power windows
- Sidewall 358
- SIRIUS satellite radio\* see Satellite radio\*
- SmartKey see Key, SmartKey
- SmartKey with KEYLESS-GO\* (Canada only) see Key, SmartKey with KEYLESS-GO\* (Canada only)
- Snow chains 361
- Spare wheel see Minispare wheel
- Speed settings
  - Cruise control 244, 245
  - Setting current 242
  - To last stored speed (“Resume” function) in Cruise control 245
- Speedometer 168

- SRS 47
  - Indicator lamp 27, 382
  - Messages in display 416
- Standing lamps 434, 436
  - Replacing bulbs 431
- Standing water, Driving through 318
- Starter switch 82
  - Positions 82
- Starting difficulties, Engine 129
- Starting, Engine 126
- Steering wheel 93, 94
  - Adjustment, electrical 94
  - Adjustment, manual 93
  - Buttons 28
  - Cleaning 371
  - Easy entry/exit feature\*
    - (Canada only) 95
  - Power steering fluid 478
- Stolen Vehicle Recovery services 302
- Storage compartments 283
  - Cup holder 287
  - Front armrest 284
  - Parcel net 285
  - Rear armrest 286
  - Storage compartment in front
    - armrest 284
  - Storage pockets 286
- Storing tires 333
- Submenus see Control system submenus
- Summer opening feature 123
- Sun visors 289
- Sunroof see Power tilt/sliding sunroof
- Sunshade
  - Extending/retracting rear window
    - sunshade 290
- Switching
  - Fuel (Flexible fuel vehicle) 483
- Symbols used in this operator's
  - manual 14
- System settings
  - Bluetooth® (Audio system) 192
  - Display (Audio system) 192
  - Setting the system language 193
- System settings (Audio system)
  - Menu overview 192
  - Reset to factory settings 193
  - Setting the system language 193
- T**
- Tachometer 149
  - Overspeed range 149
- Tail lamps
  - Cleaning lenses 367
  - Replacing bulbs 431, 436
- Tar stains 365
- Technical data
  - Flexible fuel vehicles 482
- Tele Aid\* 295
  - Automatic Maintenance Call 302
  - Call priority 301
  - Emergency calls 296
  - Hands-free microphone 31
  - Information 300
  - Information button\* 300
  - Initiating an emergency call
    - manually 298
  - Messages in display 418
  - Remote door lock 302
  - Remote door unlock\* 301
  - Roadside Assistance button\* 299, 300
  - Roadside Assistance\* 299
  - SOS button 298
  - Stolen Vehicle Recovery



- services 302
- System self-check 296
- Telephone\* 28, 152
  - “911” emergency call
    - (Audio system) 231
  - Answering/ending a call 163
  - Hands-free microphone 31
  - Operation 160
  - Operation (Audio system) 222
  - Phone book 162
  - Redialing 163
  - Redialing (Instrument cluster control system) 163
  - Switching on/off (Audio system) 226
- Temperature
  - Display mode 158
  - Interior temperature 253
  - Outside temperature indicator 27
  - Tires 340
- Tightening torque, Wheel bolts 445
- Tilt/sliding sunroof see Power tilt/sliding sunroof
- Time 170
- TIN 358
- Tire and Loading Information
  - Placard 335
- Tire Identification Number see TIN
- Tire inflation pressure
  - Air pressure 339, 356
  - Checking tire pressure electronically, Tire Pressure Monitoring System (TPMS), (USA only) 344
- Tires 331
  - And Rims 467
  - And Wheels 331
  - Care and maintenance 332
  - Chains 361
  - Cleaning 333
  - Cold tire inflation pressure 356
  - Direction of rotation 334
  - Driving instructions 315
  - Important notes on tire inflation pressure 340
  - Inflation pressure 339
  - Information placard 335
  - Inspection 332
  - Load rating 349, 358
  - Load rating, Maximum 353, 357
  - Low tire pressure telltale 383
  - Minispare wheel 422, 471
  - Ply composition and material used 358
- Problems under-/overinflation 339
- Retreads 331
- Rotating 359
- Run Flat Indicator\*
  - (Canada only) 342
- Service life 332
- Sizes 467
- Snow 360
- Speed rating 316, 350, 358
- Storing 333
- Temperature 340, 355
- Terminology 356
- Tire Pressure Monitoring System (TPMS)\*, (USA only) 344
- Total load limit 358
- TPMS\* (USA only) malfunction telltale 383
- Traction 316, 358
- Tread depth 333
- Tread depth, Winter 360
- Treadwear indicators 358
- Vehicle maximum load on 359
- Wear pattern 359
- Winter 360

Tools 420  
 Top tether  
   Children in the vehicle 54  
 Towing eye bolt (vehicle tool kit) 420, 455  
 Towing the vehicle 453  
 Tow-start 451, 453  
 TPMS, Tire Pressure Monitoring System\* (USA only) 344  
 Traction 316, 355, 358  
 Transmission gear selector lever see Gear selector lever\*  
 Transmission see Automatic transmission\*  
 Traveling abroad 318  
 Tread 358  
 Tread depth, Tires 333  
 Tread depth, Winter tires 360  
 Treadwear indicators 358  
 Trip computer 156  
 Trip odometer  
   Resetting 157

Trunk  
   Closing 269, 424  
   Closing trunk from inside 269  
   Closing trunk from outside 269  
   Emergency release 271  
   Lighting 116  
   Message in display 419  
   Opening from inside 269  
   Opening from outside 269  
   Unlocking in an emergency 424  
   Valet locking 272  
 Tumbler holder see Cup holder  
 Turn signal lamps  
   Cleaning lenses 367  
   Replacing bulbs (Bi-Xenon\*) 436  
   Replacing bulbs (Halogen) 434  
   Replacing bulbs (rear) 436  
 Turn signals 131  
   Additional in mirrors 431  
   Bulbs 431  
   Bulbs (Bi-Xenon) 436  
   Bulbs (Halogen) 434  
   Indicator lamp 27  
   Messages in display 413

## U

Uniform Tire Quality Grading Standards 359  
 Units, Setting  
   Speedometer 168  
 Uphill driving  
   Cruise control 243  
 Upholstery  
   Cleaning 372  
 Useful features 289

## V

Valet locking 272  
 Vanity mirrors  
   In the sun visor 289  
 Vehicle  
   Battery 446  
   Breaking-in period 310  
   Care 364  
   Dimensions 474  
   Individual settings 165, 166  
   Locking/unlocking 70, 73  
   Locking/unlocking in an emergency 424  
   Lowering 445  
   Service battery 446  
   Towing 453

- Washing 364, 366
- Weights 475
- With flexible fuel 482
- Vehicle data recording 18
- Vehicle jack 421
- Vehicle loading 280, 334
  - Instructions 282
  - Load limit 335
  - Roof rack\* 280
  - Split rear bench seat\* 281
  - Terminology 356
- Vehicle maximum load on the tire 359
- Vehicle Recovery services, Stolen (Tele Aid\*) 302
- Vehicle status message memory 164
- Vehicle tool kit 420
- VIN 463

## W

- Warning sounds
  - Drivers seat belts 48
  - Seat belt telltale 381
- Warranty coverage 461
- Washing the vehicle 364
- Wear pattern, Tires 359
- Weights, Vehicle 475
- Wheels
  - Change 440
  - Collapsible wheel chock 423
  - Minispare wheel 422, 471
  - Removing 444
  - Rims and Tires 467
  - Sizes 467
  - Tightening torque 445
  - Tires and wheels 331
- Window curtain air bags 40, 41
- Windows see Power windows
- Windshield
  - Cleaning 368
  - Cleaning wiper blades 368
  - Defogging 255

- Windshield washer fluid 479, 486
  - Mixing ratio 486
  - Refilling 330
  - Wiping with 119
- Windshield wipers 117
  - Cleaning wiper blades 368
  - Replacing wiper blades 438
  - Single wipe 118
- Winter driving 360
  - Snow chains 361
  - Tires 360
- Winter driving instructions 317
- Winter tires 360
- Wood trims, Cleaning 372
- Wrench, wheel (vehicle tool kit) 420

## Service and Literature

Your authorized Mercedes-Benz Center has trained technicians and Genuine Mercedes-Benz Parts to service your vehicle properly.  
For expert advice and quality service, contact an authorized Mercedes-Benz Center.

If you are interested in obtaining service literature for your vehicle, please contact an authorized Mercedes-Benz Center.  
We consider this the best way for you to obtain accurate information for your vehicle.

For further information you can find us on the Mercedes-Benz web-site [www.mbusa.com](http://www.mbusa.com) or [www.mercedes-benz.ca](http://www.mercedes-benz.ca).

### Warning!



To help avoid personal injury, be extremely careful when performing any service work or repairs. Improper or incomplete service or the use of incorrect or inappropriate parts or materials may damage the vehicle or its equipment, which may in turn result in personal injury.

If you have any questions about carrying out any type of service, turn to the advice of an authorized Mercedes-Benz Center.

We reserve the right to make changes in design and equipment.

Therefore, information, illustrations and descriptions in this Operator's Manual might differ from your vehicle.  
Reprinting, translation and copying, even of excerpts, is not permitted without our prior authorization in writing.

Press time June 15, 2007

GSP/TID

Printed in U.S.A

