



Operator's Manual  
G-Class



Mercedes-Benz



4 6 3 5 8 4 4 7 8 1

Order No. 6515 4078 13 Part No. 463 584 47 81 USA Edition B 2007

G-Class

G 500

G 55 AMG

Our company and staff congratulate you on the purchase of your new Mercedes-Benz.

Your selection of our product is a demonstration of your trust in our company name. Furthermore, it exemplifies your desire to own an automobile that will be as easy as possible to operate and provide years of service.

Your Mercedes-Benz represents the efforts of many skilled engineers and craftsmen. To help assure your driving pleasure, and also the safety of you and your passengers, we ask you to make a small investment of time:

- Please read this manual carefully, then return it to your vehicle where it will be handy for your reference.
- Please follow the recommendations contained in this manual. They are designed to acquaint you with the operation of your Mercedes-Benz.
- Please pay attention to the warnings and cautions contained in this manual. They are designed to help improve the safety of the vehicle operator and occupants.

We extend our best wishes for many miles of safe, pleasurable driving.

Mercedes-Benz USA, LLC  
A DaimlerChrysler Company

|  |    |
|--|----|
| <b>Introduction</b> .....  | 9  |
| Product information.....   | 9  |
| Operator's Manual .....  | 10 |
| Service and warranty information ..  | 10 |
| Important notice for California<br>retail buyers and lessees of<br>Mercedes-Benz automobiles ..... | 11 |
| Maintenance .....  | 12 |
| Roadside Assistance .....  | 12 |
| Change of address or ownership....   | 13 |
| Operating your vehicle outside<br>the USA or Canada.....   | 13 |
| Where to find it.....  | 15 |
| Symbols.....   | 16 |
| Operating safety .....   | 17 |
| Proper use of the vehicle .....  | 17 |
| Problems with your vehicle.....  | 18 |
| Reporting safety defects.....  | 19 |
| Reporting safety defects .....   | 19 |
| Vehicle data recording.....  | 20 |
| Information regarding electronic<br>recording devices.....   | 20 |

|                                    |    |
|------------------------------------|----|
| <b>At a glance</b> .....           | 21 |
| Exterior view.....                 | 22 |
| Cockpit.....                       | 24 |
| Instrument cluster .....           | 26 |
| Multifunction steering wheel ..... | 28 |
| Center console .....               | 30 |
| Upper part .....                   | 30 |
| Lower part .....                   | 31 |
| Overhead control panel .....       | 32 |
| Door control panel.....            | 33 |
| Storage compartments.....          | 34 |

|                                   |    |
|-----------------------------------|----|
| <b>Getting started</b> .....      | 37 |
| Unlocking .....                   | 38 |
| Unlocking with the SmartKey ..... | 38 |
| Starter switch positions.....     | 39 |
| Adjusting .....                   | 41 |
| Seats .....                       | 41 |
| Steering wheel.....               | 44 |
| Mirrors.....                      | 46 |
| Driving.....                      | 48 |
| Fastening the seat belts .....    | 48 |
| Starting the engine .....         | 54 |
| Parking brake .....               | 55 |
| Driving off .....                 | 55 |
| Switching on headlamps.....       | 56 |
| Turn signals .....                | 57 |
| Windshield wipers.....            | 58 |
| Rear window wiper/washer .....    | 60 |
| Problems while driving.....       | 61 |
| Parking and locking.....          | 62 |
| Parking brake .....               | 62 |
| Switching off headlamps.....      | 64 |
| Turning off engine .....          | 64 |
| Releasing seat belts.....         | 64 |
| Locking .....                     | 65 |

|                                  |    |                                       |     |                                      |     |
|----------------------------------|----|---------------------------------------|-----|--------------------------------------|-----|
| <b>Safety and Security</b> ..... | 67 | <b>Controls in detail</b> .....       | 99  | Lighting .....                       | 117 |
| Occupant safety .....            | 68 | Locking and unlocking .....           | 100 | Exterior lamp switch .....           | 117 |
| Air bags .....                   | 70 | SmartKey .....                        | 100 | Combination switch .....             | 122 |
| Seat belts .....                 | 74 | Checking batteries in                 |     | Corner-illuminating front fog        |     |
| Children in the vehicle .....    | 78 | the SmartKey .....                    | 103 | lamps .....                          | 122 |
| Blocking of rear door window     |    | Loss of the SmartKey .....            | 103 | Hazard warning flasher .....         | 124 |
| operation .....                  | 86 | Opening the doors from                |     | Interior lighting in the front ..... | 125 |
| Panic alarm .....                | 87 | the inside .....                      | 104 | Rear interior lamps .....            | 126 |
| Activating .....                 | 87 | Tailgate .....                        | 105 | Cargo compartment lamps .....        | 127 |
| Deactivating .....               | 87 | Automatic central locking .....       | 106 | Door entry lamps .....               | 129 |
| Driving safety systems .....     | 88 | Locking and unlocking from            |     | Instrument cluster .....             | 130 |
| ABS .....                        | 88 | the inside .....                      | 107 | Adjusting instrument cluster         |     |
| BAS .....                        | 90 | Seats .....                           | 108 | illumination .....                   | 130 |
| 4-ETS .....                      | 91 | Removing and installing front         |     | Coolant temperature gauge .....      | 131 |
| EBB .....                        | 92 | seat head restraints .....            | 108 | Resetting trip odometer .....        | 131 |
| ESP® .....                       | 92 | Multicontour seat* .....              | 109 | Tachometer .....                     | 132 |
| Anti-theft systems .....         | 96 | Rear seats .....                      | 110 | Outside temperature indicator .....  | 132 |
| Immobilizer .....                | 96 | Seat heating .....                    | 112 | Control system .....                 | 133 |
| Anti-theft alarm .....           | 96 | Memory function .....                 | 114 | Multifunction display .....          | 133 |
| Tow-away alarm .....             | 98 | Storing positions into memory .....   | 115 | Multifunction steering wheel .....   | 134 |
|                                  |    | Recalling positions from memory ..... | 115 | Menus .....                          | 136 |
|                                  |    | Storing exterior rear view mirror     |     | Standard display menu .....          | 140 |
|                                  |    | parking position .....                | 116 | Audio menu .....                     | 141 |
|                                  |    |                                       |     | NAV menu .....                       | 144 |
|                                  |    |                                       |     | Vehicle status message memory        |     |
|                                  |    |                                       |     | menu .....                           | 144 |

|   |     |   |     |                                     |     |
|---|-----|---|-----|-------------------------------------|-----|
| Settings menu.....  | 146 | Climate control.....  | 182 | Loading .....                       | 206 |
| Trip computer menu.....                                     | 157 | Deactivating the climate control system .....               | 185 | Roof rack .....                     | 206 |
| TEL menu .....  | 159 | Operating the climate control system in automatic mode..... | 185 | Expanding cargo compartment.....    | 206 |
| Automatic transmission.....                                 | 162 | Setting the temperature.....                                | 185 | Split rear seat bench .....         | 206 |
| Gear selector lever.....                                    | 162 | Adjusting air distribution.....                             | 186 | Loading instructions .....          | 208 |
| Shifting procedure .....                                    | 163 | Adjusting air volume .....                                  | 186 | Cargo tie-down rings.....           | 209 |
| Gear selector lever positions .....                         | 164 | Front defroster.....  | 187 | Partition net* (MB Accessory) ..... | 210 |
| Driving tips.....   | 166 | Air recirculation mode .....                                | 188 | Cargo compartment cover blind ...   | 214 |
| Gear ranges .....   | 167 | Air conditioning.....                                       | 189 | Useful features.....                | 215 |
| One-touch gearshifting.....                                 | 168 | Residual heat and ventilation.....                          | 190 | Storage compartments .....          | 215 |
| Emergency operation (Limp-Home Mode) .....                  | 169 | Rear passenger compartment adjustable air vents.....        | 191 | Ashtrays.....                       | 220 |
| Transfer case.....  | 170 | Power windows .....   | 192 | Cigarette lighter.....              | 222 |
| Transfer case position.....                                 | 170 | Opening and closing .....                                   | 192 | Electrical outlet.....              | 223 |
| Switching transfer case.....                                | 170 | Summer opening feature .....                                | 193 | Floormats .....                     | 224 |
| Differential locks .....                                    | 173 | Convenience closing feature.....                            | 194 | Heated steering wheel.....          | 225 |
| A few words about differentials and differential locks..... | 174 | Power tilt/sliding sunroof.....                             | 195 | Telephone* .....                    | 226 |
| Switching differential locks on and off.....                | 175 | Opening and closing .....                                   | 195 | Tele Aid.....                       | 229 |
| Good visibility .....                                       | 177 | Driving systems.....  | 197 | Garage door opener.....             | 236 |
| Headlamp cleaning system .....                              | 177 | Cruise control .....  | 197 |                                     |     |
| Rear view mirrors.....                                      | 177 | Rear Parking Assist.....                                    | 200 |                                     |     |
| Sun visors .....  | 179 | Rear view camera .....                                      | 203 |                                     |     |
| Windshield defroster .....                                  | 180 |   |     |                                     |     |
| Rear window defroster .....                                 | 181 |   |     |                                     |     |

# Contents

|                                       |     |                                      |     |                                    |     |
|---------------------------------------|-----|--------------------------------------|-----|------------------------------------|-----|
| <b>Operation</b> .....                | 243 | At the gas station .....             | 264 | Maximum tire load .....            | 300 |
| The first 1 000 miles (1 500 km)..... | 244 | Refueling .....                      | 264 | Maximum tire inflation pressure .. | 301 |
| Driving instructions.....             | 245 | Check regularly and before           |     | Uniform Tire Quality Grading       |     |
| Drive sensibly – save fuel .....      | 245 | a long trip.....                     | 265 | Standards (U.S. vehicles).....     | 302 |
| Drinking and driving .....            | 245 | Engine compartment .....             | 267 | Tire ply material .....            | 304 |
| Pedals .....                          | 245 | Hood .....                           | 267 | Tire and loading terminology.....  | 304 |
| Power assistance .....                | 246 | Engine oil .....                     | 269 | Rotating tires .....               | 307 |
| Brakes .....                          | 246 | Transmission fluid level.....        | 273 | Winter driving .....               | 309 |
| Driving off.....                      | 247 | Coolant level .....                  | 274 | Winter tires .....                 | 309 |
| Parking.....                          | 248 | Windshield/rear window washer        |     | Block heater (Canada only).....    | 310 |
| Tires .....                           | 248 | system and headlamp cleaning         |     | Snow chains.....                   | 310 |
| Hydroplaning.....                     | 249 | system .....                         | 275 | Maintenance.....                   | 311 |
| Tire traction.....                    | 249 | Tires and wheels.....                | 277 | Maintenance service indicator      |     |
| Tire speed rating .....               | 250 | Important guidelines .....           | 277 | message .....                      | 311 |
| Winter driving instructions .....     | 251 | Tire care and maintenance.....       | 278 | Calling up the maintenance         |     |
| Standing water .....                  | 252 | Direction of rotation .....          | 280 | service indicator display .....    | 313 |
| Passenger compartment .....           | 252 | Loading the vehicle .....            | 280 | Resetting the maintenance          |     |
| Off-road driving .....                | 253 | Recommended tire inflation           |     | service indicator .....            | 313 |
| Driving abroad.....                   | 261 | pressure.....                        | 286 | Vehicle care.....                  | 314 |
| Control and operation of radio        |     | Checking tire inflation pressure ... | 288 | Cleaning and care of the vehicle.. | 314 |
| transmitters.....                     | 261 | Tire labeling.....                   | 294 |                                    |     |
| Catalytic converter.....              | 262 | Load identification .....            | 298 |                                    |     |
| Emission control.....                 | 263 | DOT, Tire Identification Number      |     |                                    |     |
| Coolant temperature .....             | 263 | (TIN) .....                          | 299 |                                    |     |

|  |     |  |     |   |     |
|--|-----|--|-----|---|-----|
| <b>Practical hints</b> .....                                 | 323 | Opening/closing in an emergency .....  | 374 | Jump starting.....                                      | 399 |
| What to do if ... ..   | 324 | Tilt/sliding sunroof .....   | 374 | Towing the vehicle.....                                 | 401 |
| Lamps in instrument cluster .....                            | 324 | Brush guard.....   | 375 | Transporting the vehicle .....                          | 403 |
| Lamp in center console.....                                  | 337 | Lowering and raising<br>brush guard.....                                       | 375 | Towing the vehicle - various<br>problem scenarios ..... | 403 |
| Vehicle status messages in the<br>multifunction display..... | 338 | Replacing SmartKey batteries .....   | 376 | Front towing eye.....                                   | 404 |
| Where will I find...? .....                                  | 366 | Replacing bulbs .....  | 377 | Rear towing eye.....                                    | 404 |
| First aid kit.....   | 366 | Bulbs.....   | 377 | Stranded vehicle.....                                   | 404 |
| Vehicle tool kit.....  | 366 | Replacing bulbs for front lamps ...  | 380 | Fuses.....  | 405 |
| Vehicle jack.....  | 367 | Replacing bulbs for rear lamps ....  | 385 | Main fuse box in passenger<br>compartment .....         | 406 |
| CD changer .....   | 368 | Replacing wiper blades.....  | 388 | Fuse box in front passenger<br>footwell.....            | 406 |
| Spare wheel .....  | 368 | Wiper blades .....   | 388 | Fuse box in middle tunnel.....                          | 407 |
| Unlocking/locking in an emergency..                          | 370 | Flat tire.....   | 390 | Fuse box in battery box .....                           | 408 |
| Unlocking the vehicle.....                                   | 370 | Preparing the vehicle .....  | 390 |   |     |
| Locking the vehicle .....                                    | 371 | Mounting the spare wheel .....   | 391 |   |     |
| Fuel filler flap .....                                       | 372 | Battery.....   | 396 |   |     |
| Manually unlocking the gear<br>selector lever .....          | 373 | Disconnecting, removing,<br>reinstalling and reconnecting<br>the battery ..... | 398 |   |     |
|  |     | Charging the battery .....   | 398 |   |     |



|                                   |     |  |     |                    |     |
|-----------------------------------|-----|--|-----|--------------------|-----|
| <b>Technical data</b> .....       | 409 | Fuels, coolants, lubricants, etc. .... | 422 | <b>Index</b> ..... | 431 |
| Parts service .....               | 410 | Capacities .....                       | 422 |                    |     |
| Warranty coverage.....            | 411 | Engine oils.....                       | 425 |                    |     |
| Loss of Service and Warranty      |     | Engine oil additives .....             | 425 |                    |     |
| Information Booklet.....          | 411 | Air conditioning refrigerant .....     | 425 |                    |     |
| Identification labels.....        | 412 | Brake fluid.....                       | 425 |                    |     |
| Layout of poly-V-belt drive ..... | 414 | Premium unleaded gasoline .....        | 426 |                    |     |
| G 500 .....                       | 414 | Fuel requirements .....                | 426 |                    |     |
| G 55 AMG.....                     | 414 | Gasoline additives.....                | 427 |                    |     |
| Engine.....                       | 415 | Coolants.....                          | 427 |                    |     |
| Rims and tires.....               | 416 | Windshield/rear window washer          |     |                    |     |
| Same size tires.....              | 417 | system and headlamp cleaning           |     |                    |     |
| Spare wheel .....                 | 418 | system .....                           | 430 |                    |     |
| Electrical system.....            | 419 |  |     |                    |     |
| Main dimensions, vehicle weights  |     |  |     |                    |     |
| and ratings.....                  | 420 |  |     |                    |     |
| Main dimensions .....             | 420 |  |     |                    |     |
| Vehicle weights and ratings ..... | 421 |  |     |                    |     |

### ▼ Product information

Please observe the following in your own best interest:

We recommend using Genuine Mercedes-Benz Parts as well as conversion parts and accessories explicitly approved by us for your vehicle model.

We have tested these parts to determine their reliability, safety and special suitability for Mercedes-Benz vehicles.

We are unable to make an assessment for other products and therefore cannot be held responsible for them, even if in individual cases an official approval or authorization by governmental or other agencies should exist. Use of such parts and accessories could adversely affect the safety, performance or reliability of your vehicle. Please do not use them.

Genuine Mercedes-Benz Parts as well as conversion parts and accessories approved by us are available at any authorized Mercedes-Benz Light Truck Center where you will receive comprehensive information, also on permissible technical modifications, and where proper installation will be performed.

This Operator's Manual contains a great deal of useful information. We urge you to read it carefully and familiarize yourself with the vehicle before driving.

For your own safety and longer service life of the vehicle, we urge you to follow the instructions and warnings contained in this manual. Ignoring them could result in damage to the vehicle or personal injury to you or others. Vehicle damage caused by failure to follow instructions is not covered by the Mercedes-Benz Limited Warranty.

Your vehicle may have some or all of the equipment described in this manual. Therefore, you may find explanations for optional equipment not installed in your vehicle. If you have any questions about the operation of any equipment, any authorized Mercedes-Benz Light Truck Center will be glad to demonstrate the proper procedures.

We continuously strive to improve our product, and ask for your understanding that we reserve the right to make changes in design and equipment. Therefore, information, illustrations and descriptions in this Operator's Manual might differ from your vehicle.

Optional equipment is also described in this manual, including operating instructions wherever necessary. Since they are special-order items, the descriptions and illustrations herein may vary slightly from the actual equipment of your vehicle.

If there are any equipment details that are not shown or described in this Operator's Manual, any authorized Mercedes-Benz Light Truck Center will be glad to inform you of correct care and operating procedures.

The Operator's Manual and Maintenance Booklet are important documents and should be kept with the vehicle.

### Service and warranty information

The Service and Warranty Information Booklet contains detailed information about the warranties covering your Mercedes-Benz, including:

- New Light Truck Limited Warranty
- Emission System Warranty
- Emission Performance Warranty
- California, Maine, Massachusetts, Vermont Emission Control System Warranty (California, Maine, Massachusetts, and Vermont only)
- State Warranty Enforcement Laws (Lemon Laws)

### **Important notice for California retail buyers and lessees of Mercedes-Benz automobiles**

---

Under California law you may be entitled to a replacement of your vehicle or a refund of the purchase price or lease price, if Mercedes-Benz USA, LLC and/or its authorized repair or service facilities fail to fix one or more substantial defects or malfunctions in the vehicle that are covered by its express warranty after a reasonable number of repair attempts. During the period of 18 months from original delivery of the vehicle or the accumulation of 18000 miles (approximately 29000 km) on the odometer of the vehicle, whichever occurs first, a reasonable number of repair attempts is presumed for a retail buyer or lessee if one or more of the following occurs:

- (1) the same substantial defect or malfunction results in a condition that is likely to cause death or serious bodily injury if the vehicle is driven, that defect or malfunction has been subject to repair two or more times, and you have directly notified Mercedes-Benz USA, LLC in writing of the need for its repair,
- (2) the same substantial defect or malfunction of a less serious nature than category (1) has been subject to repair four or more times and you have directly notified us in writing of the need for its repair, or
- (3) the vehicle is out of service by reason of repair of the same or different substantial defects or malfunctions for a cumulative total of more than 30 calendar days.

Written notification should not be sent to a dealer, it should be addressed to:  
Mercedes-Benz USA, LLC  
Customer Assistance Center  
One Mercedes Drive  
Montvale, NJ 07645-0350

#### Maintenance

---

The Maintenance Booklet describes all the necessary maintenance work which should be performed at regular intervals.

Always have the Maintenance Booklet with you when you take the vehicle to an authorized Mercedes-Benz Light Truck Center for service. The service advisor will record each service in the booklet for you.

#### Roadside Assistance

---

The Mercedes-Benz Roadside Assistance Program provides factory-trained technical help in the event of a breakdown. Calls to the toll-free Roadside Assistance number

**1-800-FOR-MERCEdes (in the USA)**  
**1-800-387-0100 (in Canada)**

will be answered by Mercedes-Benz Customer Assistance Representatives 24 hours a day, 365 days a year.

Roadside Assistance will be provided in accordance with standard program guidelines which include providing service to the vehicle up to a reasonable distance from a paved roadway. We will make every effort to assist in a breakdown situation, however, the accessibility of your vehicle will be determined by our authorized Mercedes-Benz Light Truck Center technician or the tow service provider on a case-by-case basis and may be a factor in our ability to respond.

Additional charges may be applicable for a breakdown location determined not to be a reasonably accessible roadside location as determined by our authorized technician and tow service provider.

For additional information refer to the Mercedes-Benz Roadside Assistance Program brochure in your vehicle literature portfolio.

### **Change of address or ownership**

---

If you change your address, be sure to send in the “Change of Address Notice” found in the Service and Warranty Information Booklet, or simply call the Mercedes-Benz Customer Assistance Center (in the USA) at 1-800-FOR-MERCEdes, or Customer Service (in Canada) at 1-800-387-0100. It is in your own interest that we can contact you should the need arise.

If you sell your Mercedes, please leave all literature with the vehicle to make it available to the next operator.

If you bought this vehicle used, be sure to send in the “Notice of Purchase of Used Truck” found in the Service and Warranty Information Booklet, or call the Mercedes-Benz Customer Assistance Center (in the USA) at 1-800-FOR-MERCEdes, or Customer Service (in Canada) at 1-800-387-0100.

### **Operating your vehicle outside the USA or Canada**

---

If you plan to operate your vehicle in foreign countries, please be aware that:

- service facilities or replacement parts may not be readily available,
- unleaded gasoline for vehicles with catalytic converters may not be available; the use of leaded fuels will damage the catalysts,
- gasoline may have a considerably lower octane rating, and improper fuel can cause engine damage.

Certain Mercedes-Benz models are available for delivery in Europe under our European Delivery Program. For details, consult an authorized Mercedes-Benz Light Truck Center or write to:

In the USA:

Mercedes-Benz USA, LLC  
European Delivery Department  
One Mercedes Drive  
Montvale, NJ 07645-0350

In Canada:

Mercedes-Benz Canada, Inc.  
European Delivery Department  
98 Vanderhoof Avenue  
Toronto, Ontario M4G 4C9

#### Warning!



This Sport Utility Vehicle is designed for both on-road and off-road use. It can go places and perform tasks for which conventional 2-wheel drive passenger cars are not intended. This vehicle will handle and maneuver differently from conventional passenger cars in driving conditions which may occur on streets, highways and off-road use.

This vehicle has a higher ground clearance and a higher center of gravity than many passenger cars. As with other vehicles of this type, if you make sharp turns at excessive speeds or abrupt maneuvers, the vehicle may roll over or may go out of control and crash. Utility vehicles have a significantly higher rollover rate than other types of vehicles. Failure to operate this vehicle safely may result in an accident, rollover of the vehicle, and severe or fatal injury.

Before you start to drive this vehicle, read the Operator's Manual. Take time to become familiar with the driving characteristics of this vehicle. Be sure you are familiar with all vehicle controls. Learn how your vehicle handles on different road surfaces. Do not attempt sharp turns at excessive speeds or abrupt maneuvers or other unsafe driving actions that can cause loss of vehicle control. When driving off-road or working the vehicle hard, do not overload it. And, always wear your seat belts at all times. In a rollover crash, an unbelted person is significantly more likely to die than a person wearing a seat belt.

## ▼ Where to find it

This Operator's Manual is designed to provide comprehensive support information for you, the vehicle operator. Each section has its own reference color.

### At a glance

Here you will find an overview of your vehicle's interior and exterior main features.

### Getting started

Here you will find all the information you need for your first drive. You should read this section first if this is your first Mercedes-Benz vehicle or if you are renting or borrowing this vehicle.

### Safety and Security

Here you will find descriptions of the safety and security features of your vehicle.

### Controls in detail

Here you will find detailed information about the equipment installed on your vehicle. This section expands on the "Getting started" section and also describes technical innovations. If you are already familiar with the basic functions of your vehicle, this section will be of particular interest to you.

### Operation

Here you will find all the information you need for the proper operation of your vehicle.

### Practical hints

This section provides fast assistance for dealing with problems you may encounter.

### Technical data

All important technical data for your vehicle can be found in this section.

### Indexes

The table of contents and the index are designed to help you find information quickly and easily.

The following publications are part of your vehicle documentation:

- this Operator's Manual
- the Maintenance Booklet

Separate operating instructions will be provided as required depending on the equipment options installed in your vehicle.



## Symbols

Trademarks:

- ESP® is a registered trademark of DaimlerChrysler.
- HomeLink® is a registered trademark of Prince, a Johnson Controls Company.
- BabySmart™ is a trademark of Siemens Automotive Corp.

The following symbols are found in this Operator's Manual:

- \* Optional equipment is identified with an asterisk. Since standard equipment varies between models, the descriptions and illustrations in this manual may differ slightly from the actual equipment of your vehicle.

### Warning!



Warning notices draw your attention to hazards that may endanger your health or life, or the health or life of others.

 *Highlights hazards that may result in damage to your vehicle.*

 *Helpful hints or further information you may find useful.*

- ▶ This symbol points to instructions for you to follow.
- ▶ A number of these symbols appearing in succession indicates a multiple-step procedure.
- ▷ page This symbol tells you where to look for further information on a topic.
- ▷▷ This continuation symbol marks a warning which is continued on the next page.
- ▷▷ This continuation symbol marks a procedure which is continued on the next page.
- > This symbol is used to indicate cross-references to term definitions.
- Display Words appearing in the multifunction display are printed in the type shown here.

## ▼ Operating safety

### Warning!



Work improperly carried out on electronic components and associated software could cause them to cease functioning. Because the vehicle's electronic components are interconnected, any modifications made may produce an undesired effect on other systems. Electronic malfunctions could seriously impair the operating safety of your vehicle.

See an authorized Mercedes-Benz Light Truck Center for repairs or modifications to electronic components.

Other improper work or modifications on the vehicle could also have a negative impact on the operating safety of the vehicle.

Some safety systems only function while the engine is running. You should therefore never turn off the engine while driving.

### Warning!



Heavy blows against the vehicle underbody or tires/wheels, for example when running over an obstacle, road debris or a pothole, may cause serious damage and impair the operating safety of your vehicle. If you feel a sudden significant vibration or ride disturbance, or you suspect that damage to your vehicle has occurred, you should turn on your hazard warning flashers, carefully slow down, and drive with caution to an area which is a safe distance from the road.

Inspect the vehicle underbody and tires/wheels for possible damage. If the vehicle appears unsafe, have it towed to the nearest authorized Mercedes-Benz Light Truck Center or other qualified maintenance or repair facility for further inspection or repairs.

## Proper use of the vehicle

Proper use of the vehicle requires that you are familiar with the following information and rules:

- the safety precautions in this manual
- the “Technical data” section in this manual
- traffic rules and regulations
- motor vehicle laws and safety standards

### Warning!



Various warning labels are attached to your vehicle. These warning labels are intended to make you and others aware of various risks. You should not remove any of these warning labels unless explicitly instructed to do so by information on the label itself. Removal of any of these labels may cause you and others to be unaware of certain risks which may result in an accident and/or personal injury.

### Problems with your vehicle

If you should experience a problem with your vehicle, particularly one that you believe may affect its safe operation, we urge you to immediately contact an authorized Mercedes-Benz Light Truck Center to have the problem diagnosed and corrected if required. If the matter is not handled to your satisfaction, please discuss the problem with the Mercedes-Benz Light Truck Center management, or if necessary contact us at one of the following addresses:

In the USA:

Customer Assistance Center  
Mercedes-Benz USA, LLC  
One Mercedes Drive  
Montvale, NJ 07645-0350

In Canada:

Customer Relations Department  
Mercedes-Benz Canada, Inc.  
98 Vanderhoof Avenue  
Toronto, Ontario, M4G 4C9

## ▼ Reporting safety defects

For the USA only:

The following text is published as required of manufacturers under Title 49, Code of U.S. Federal Regulations, Part 575 pursuant to the “National Traffic and Motor Vehicle Safety Act of 1966”.

### **Reporting safety defects**

---

If you believe that your vehicle has a defect which could cause a crash or could cause injury or death, you should immediately inform the National Highway Traffic Safety Administration (NHTSA) in addition to notifying Mercedes-Benz USA, LLC.

If NHTSA receives similar complaints, it may open an investigation, and if it finds that a safety defect exists in a group of vehicles, it may order a recall and remedy campaign. However, NHTSA cannot become involved in individual problems between you, your dealer, or Mercedes-Benz USA, LLC.

To contact NHTSA, you may call the Vehicle Safety Hotline toll-free at 1-888-327-4236 (TTY: 1-800-424-9153); go to <http://www.safercar.gov>; or write to: Administrator, NHTSA, 400 Seventh Street, SW., Washington, D.C. 20590. You can also obtain other information about motor vehicle safety from <http://www.safercar.gov>.

### Vehicle data recording

#### Information regarding electronic recording devices

---

(Including notice pursuant to California Code § 995.1)

Please note that your vehicle is equipped with devices that can record vehicle systems data and, if equipped with the Tele Aid system, may transmit some data in certain accidents.

This information helps, for example, to diagnose vehicle systems after a collision and to continuously improve vehicle safety. DaimlerChrysler may access the information and share it with others

- for safety research or vehicle diagnosis purposes
- with the consent of the vehicle owner or lessee
- in response to an official request by law enforcement or other government agency
- for use in dispute resolution involving DaimlerChrysler, its affiliates or sales/service organization and/or
- as otherwise required or permitted by law.

Please check the Tele Aid subscription service agreement for details regarding the information that may be recorded or transmitted via that system.



**Exterior view**

**Cockpit**

**Instrument cluster**

**Multifunction steering wheel**

**Center console**

**Overhead control panel**

**Door control panel**

**Storage compartments**

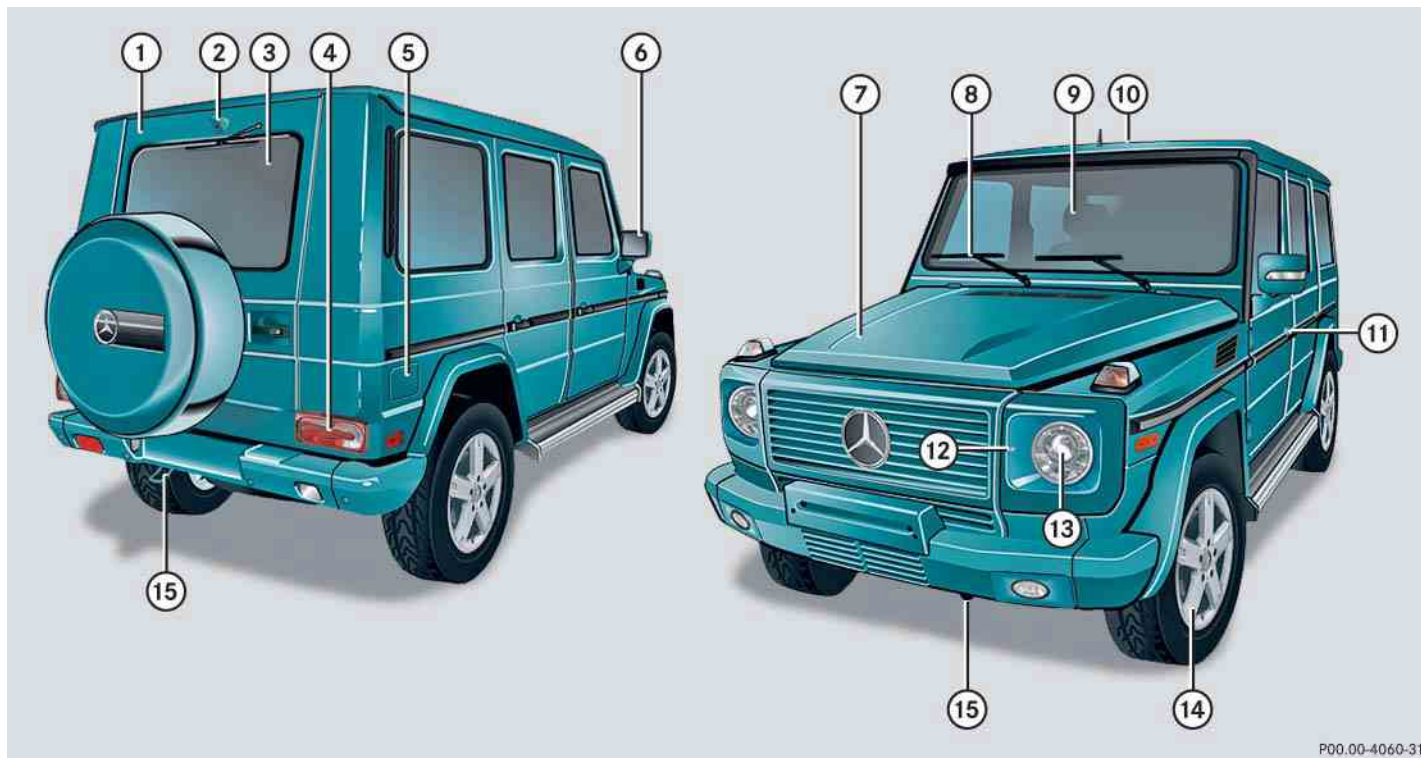

P00.00-4060-31

| Item                    | Page        |
|-------------------------|-------------|
| ① Tailgate              | 105         |
| Cargo compartment       |             |
| • Loading instructions  | 208         |
| • Expanding             | 206         |
| • Cargo tie-down rings  | 209         |
| • Partition net*        | 210         |
| • Cover blind           | 214         |
| ② Rear view camera      | 203         |
| ③ Rear window defroster | 181         |
| ④ Rear lamps            | 378         |
| ⑤ Fuel filler flap      | 264         |
| Refueling               | 264         |
| Fuel                    | 265,<br>426 |

| Item                                  | Page |
|---------------------------------------|------|
| ⑥ Exterior rear view mirrors          |      |
| Adjusting                             | 46   |
| Auto-dimming rear view mirrors        | 177  |
| ⑦ Hood                                | 267  |
| Engine oil                            | 269  |
| Coolant                               | 274  |
| ⑧ Windshield wipers                   | 58   |
| Wiper blades, replacing               | 388  |
| Wiper blades, cleaning                | 319  |
| ⑨ Windshield                          |      |
| Cleaning with windshield washer fluid | 59   |
| Cleaning                              | 319  |
| Windshield defroster                  | 180  |
| ⑩ Power tilt/sliding sunroof          | 195  |

| Item                              | Page        |
|-----------------------------------|-------------|
| ⑪ Doors                           |             |
| Locking and unlocking             | 100         |
| Opening and closing               | 104         |
| Locking/unlocking in an emergency | 370         |
| ⑫ Headlamp cleaning system        | 177         |
| ⑬ Front lamps                     | 378         |
| ⑭ Tires and wheels                | 277,<br>416 |
| Checking tire inflation pressure  | 288         |
| General information               | 277         |
| Flat tire                         | 390         |
| Spare wheel                       | 368         |
| ⑮ Front towing eye                | 404         |
| Rear towing eye                   | 404         |



## Cockpit



P48\_10-3742-31







| Item   | Page |
|--|------|
| ① Combination switch   |      |
| • High beam  | 57   |
| • Turn signals   | 57   |
| • Windshield wipers  | 58   |
| ② Headlamp cleaning button   | 177  |
| ③ Cruise control lever   | 197  |
| ④ Horn   |      |
| ⑤ Instrument cluster   | 26   |
| ⑥ Lever for Voice Control System*, see separate operating instructions |      |
| ⑦ Starter switch   | 39   |
| ⑧ Glove box release  | 215  |
| Glove box lock   | 216  |





| Item                                   | Page       |
|--|------------|
| ⑨ Glove box                            | 215        |
| ⑩ Center console                       | 30         |
| ⑪ Multifunction steering wheel         | 28         |
| ⑫ Hood lock release                    | 267        |
| ⑬ Steering wheel adjustment stalk      | 44         |
| Heated steering wheel                  | 225        |
| ⑭ Exterior lamp switch                 | 56,<br>117 |
| ⑮ Exterior rear view mirror adjustment | 46         |



Instrument cluster



P54.32-4848-31





| Item   | Page        |
|--|-------------|
| ① <b>Speedometer with:</b>   |             |
|  Electronic Stability Program (ESP®) warning lamp                 | 92,<br>330  |
|  Brake warning lamp, USA only                                     | 55,<br>326  |
|  Brake warning lamp, Canada only                                  | 55,<br>326  |
|  Low beam headlamp indicator lamp                                 | 56,<br>118  |
|  Combination low tire pressure/Advanced TPMS malfunction telltale | 335         |
| ②  Left turn signal indicator lamp                                | 57          |
| ③ <b>Multifunction display with:</b>   | 133         |
| • Trip odometer  | 131,<br>140 |
| • Main odometer  | 140         |
| • Transfer case indicator  | 170         |





| Item   | Page        |
|--|-------------|
| • Gear selector lever position indicator   | 164         |
| • Gear range indicator   | 167         |
| • Status indicator:  |             |
| • Outside temperature  | 132,<br>133 |
| • Digital speedometer  | 133         |
| • Clock  | 133         |
| ④  Right turn signal indicator lamp                 | 57          |
| ⑤ <b>Tachometer with:</b>  |             |
|  Antilock Brake System (ABS) indicator lamp         | 88,<br>324  |
|  Seat belt telltale                                 | 74,<br>332  |
|  Supplemental Restraint System (SRS) indicator lamp | 68,<br>334  |
|  Engine malfunction indicator lamp, USA only        | 328         |

| Item  | Page        |
|---|-------------|
|  Engine malfunction indicator lamp, Canada only  | 328         |
|  High beam headlamp indicator lamp   | 57,<br>122  |
| ⑥ <b>Fuel gauge with:</b>   |             |
| Fuel tank reserve warning lamp  | 331         |
|  Fuel filler flap indicator: The fuel filler flap is located on the rear right-hand side | 264         |
| ⑦ Coolant temperature gauge   | 131         |
| ⑧ <b>Reset button for:</b>  |             |
| • Resetting trip odometer   | 131         |
| • Resetting all settings  | 146         |
| • Resetting individual settings   | 158,<br>312 |
| • Adjusting instrument cluster illumination   | 130         |

## Multifunction steering wheel



| Item  | Page        |
|---|-------------|
| ① Multifunction display   | 133         |
| <b>Operating the control system</b>   | 134         |
| ② Selecting a submenu or setting the volume:<br>Press button  |             |
|  up/to increase                              |             |
|  down/to decrease                            |             |
| ③ Telephone*:   | 159,<br>226 |
| Press button  |             |
|  to take a call<br>to dial<br>to redial      |             |
|  to end a call<br>to reject an incoming call |             |

| Item   | Page |
|--|------|
| ④ Menu systems:<br>Press button  |      |
|  for next menu        |      |
|  for previous menu    |      |
| ⑤ Moving within a menu:<br>Press button  |      |
|  for next display     |      |
|  for previous display |      |

**i** *Canada vehicles:*

*The steering wheel in this vehicle may vary from steering wheel shown. However, multifunction steering wheel symbols and feature description apply to Canada vehicles as well.*

**i** *G 55 AMG:*

*The steering wheel in this vehicle may vary from steering wheel shown. However, multifunction steering wheel symbols and feature description apply to AMG vehicles as well.*

## Center console

### Upper part

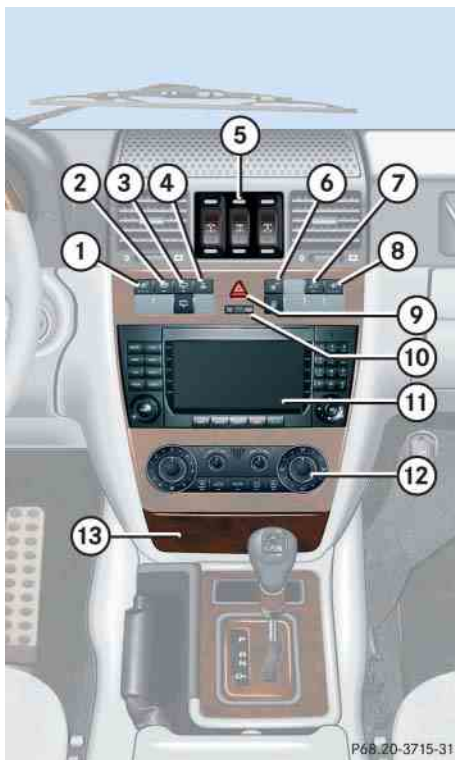

| Item   | Page |
|--|------|
| ① Seat heating, driver's side                | 112  |
| ② Windshield defroster switch                | 180  |
| ③ Rear window wiper/washer switch            | 60   |
| ④ Electronic Stability Program (ESP®) switch | 94   |
| ⑤ Differential lock switches                 | 175  |
| ⑥ Central unlocking switch                   | 107  |
| Central locking switch                       | 107  |
| ⑦ Alarm system indicator lamp                | 97   |
| Tow-away alarm off switch                    | 98   |
| ⑧ Seat heating, front passenger side         | 112  |

| Item   | Page    |
|--|---------|
| ⑨ Hazard warning flasher switch                      | 124     |
| ⑩ Front passenger front air bag off indicator lamp   | 81, 337 |
| ⑪ COMAND system, see separate operating instructions |         |
| ⑫ Climate control                                    | 182     |
| ⑬ Ashtray  | 220     |
| Cigarette lighter                                    | 222     |

## Lower part



P6B.20-3716-31

| Item   | Page       |
|--|------------|
| ① Storage tray                                   |            |
| ② Gear selector lever for automatic transmission | 54,<br>162 |
| ③ Transfer case switch                           | 170        |
| ④ Parking brake lever                            | 55,<br>62  |



## Overhead control panel



| Item  | Page        |
|---|-------------|
| ① Tele Aid (emergency call system) button                                   | 231         |
| ② Cargo compartment lamps on/off  | 127         |
| ③ Right reading lamp on/off   | 125         |
| ④ Power tilt/sliding sunroof switch   | 195         |
| ⑤ Interior lighting control   | 125         |
| ⑥ Interior rear view mirror   | 46          |
| ⑦ Garage door opener  | 236         |
| ⑧ Hands-free microphone for Tele Aid (emergency call system) and telephone* | 226,<br>229 |
| ⑨ Left reading lamp on/off  | 125         |

## ▼ Door control panel



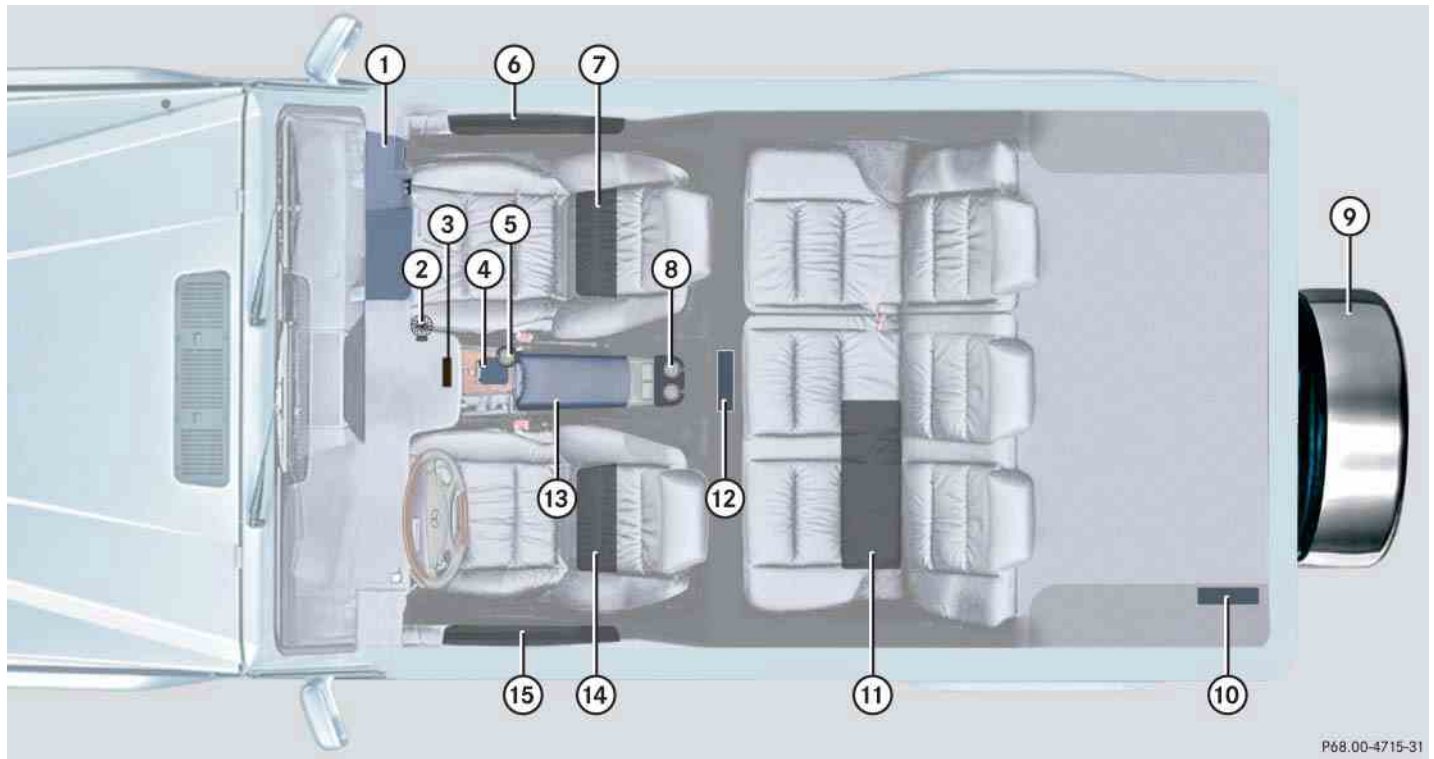

| Item   | Page       |
|--|------------|
| ① Switches for opening/closing front and rear door windows                         | 192        |
| Rear window override switch  | 86         |
| ② Seat adjustment  | 41,<br>108 |
| ③ Inside door handle   | 104        |
| ④ Memory function (for storing seat, exterior mirrors and steering wheel settings) | 114        |

Storage compartments



P68.00-4715-31

| Item   | Page |
|--|------|
| ① Glove box  | 215  |
| Parcel net in front passenger footwell                 | 218  |
| ② Cup holder in front passenger footwell               | 220  |
| ③ Storage tray   | 31   |
| ④ Storage box in front of armrest                      | 217  |
| ⑤ Cup holder next to armrest                           | 219  |
| ⑥ Storage pocket in front passenger door               |      |
| First aid kit  | 366  |
| ⑦ Ruffled storage bag on front passenger seat backrest | 217  |
| ⑧ Cup holder in rear passenger footwell                | 220  |

| Item   | Page |
|--|------|
| ⑨ Spare wheel  | 368  |
| ⑩ CD changer   | 368  |
| ⑪ Vehicle jack   | 367  |
| ⑫ Vehicle tool kit   | 366  |
| ⑬ Armrest  |      |
| • Storage/telephone* tray  | 216  |
| • Storage compartment  | 216  |
| • Roadside Assistance button  | 232  |
| • Information button          | 233  |
| ⑭ Ruffled storage bag on driver's seat backrest  | 217  |
| ⑮ Storage pocket in driver's door  |      |



Unlocking

Adjusting

Driving

Parking and locking

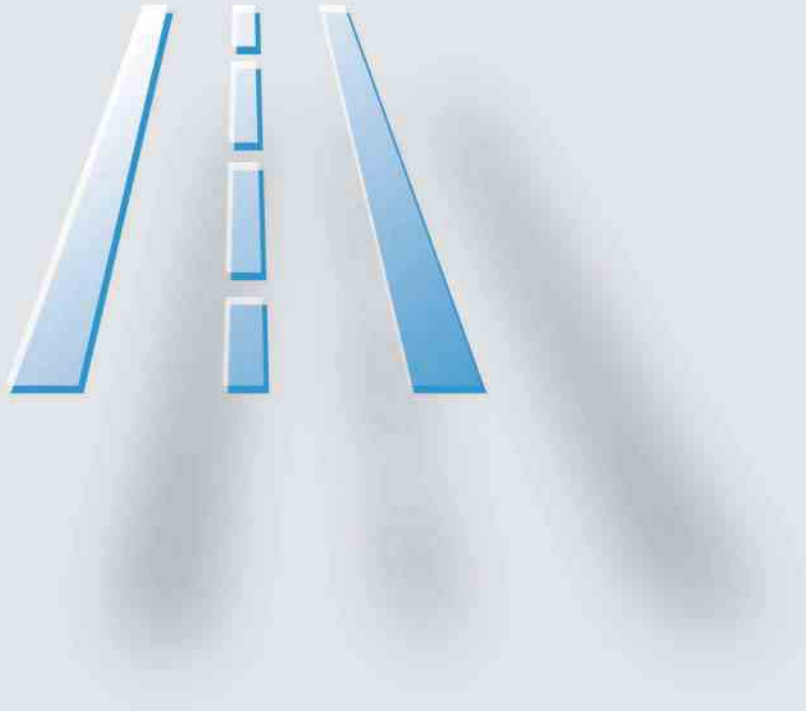

### Unlocking



The “Getting started” section provides an overview of the vehicle’s most basic functions. First-time Mercedes-Benz owners should pay special attention to the information given here.

If you are already familiar with the basic functions described here, the “Controls in detail” section (▷ page 100) will help you with further information. The corresponding page references are located at the end of each segment.

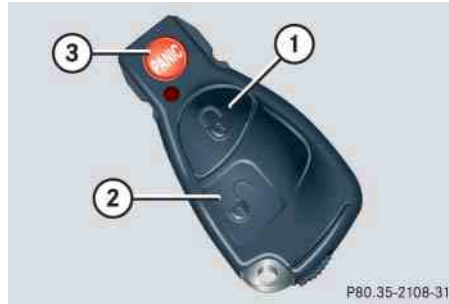
#### Unlocking with the SmartKey



#### SmartKey with remote control

- ①  Lock button
- ②  Unlock button
- ③  Panic button (▷ page 87)

#### Warning!



When leaving the vehicle, always remove the SmartKey from the starter switch, take it with you, and lock the vehicle. Do not leave children unattended in the vehicle, or with access to an unlocked vehicle. A child’s unsupervised access to a vehicle could result in an accident and/or serious personal injury.

- ▶ Press unlock button  on the SmartKey.
  - All turn signal lamps flash once.
  - The locking knobs in the doors move up.
  - The anti-theft alarm system is disarmed.
  - The locator lighting comes on if the feature is enabled in the control system (▷ page 152).
- ▶ Enter the vehicle and insert the SmartKey in the starter switch.

For more information, see “Locking and unlocking” (▷ page 100).

### Starter switch positions

#### Warning!



When leaving the vehicle, always remove the SmartKey from the starter switch, take it with you, and lock the vehicle. Do not leave children unattended in the vehicle, or with access to an unlocked vehicle. A child's unsupervised access to a vehicle could result in an accident and/or serious personal injury.

### SmartKey

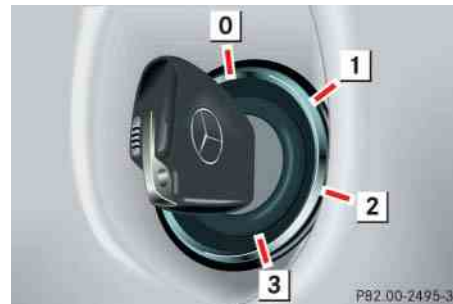

Starter switch

- 0** For removing SmartKey  
The steering is locked when the SmartKey is removed from the starter switch.
- 1** Power supply for some electrical consumers, such as seat adjustment
- 2** Ignition (power supply for all electrical consumers) and driving position  
All lamps (except high beam headlamp indicator lamp and turn signal indicator lamps unless activated) in the instrument cluster come on. If a lamp in the instrument cluster fails to come on when the ignition is switched on, have it checked and replaced if necessary. If a lamp in the instrument cluster remains on after starting the engine or comes on while driving, refer to “Lamps in instrument cluster” (▷ page 324).
- 3** Starting position



### Unlocking

**i** When you switch on the ignition, the indicator and warning lamps (except high beam headlamp indicator lamp and turn signal indicator lamps unless activated) in the instrument cluster come on. The indicator and warning lamps (except high beam headlamp indicator lamp and turn signal indicator lamps if activated) will go out when the engine is running. This indicates that the respective systems are operational.

**i** The SmartKey can only be removed from the starter switch with the gear selector lever in park position **P**.

**i** If the SmartKey is left in starter switch position **0** for an extended period of time, it can no longer be turned in the switch. In this case, the steering is locked. To unlock, remove SmartKey from the starter switch and reinsert.

**!** If the SmartKey cannot be turned in the starter switch, the battery may not be sufficiently charged.

- Check the battery and charge it if necessary (▷ page 398).
- Get a jump start (▷ page 399).

To prevent accelerated vehicle battery discharge or a completely discharged vehicle battery, always remove the SmartKey from the starter switch when the engine is not in operation.

For information on starting the engine, see (▷ page 54).

## ▼ Adjusting

### Warning!



All seat, head restraint, steering wheel, and rear view mirror adjustments, as well as fastening of seat belts, must be done before the vehicle is put into motion.

## Seats

### Warning!



Do not adjust the driver's seat while driving. Adjusting the seat while driving could cause the driver to lose control of the vehicle.

Never ride in a moving vehicle with the seat back in an excessively reclined position as this can be dangerous. You could slide under the seat belt in a collision. If you slide under it, the seat belt would apply force at the abdomen or neck. That could cause serious or fatal injuries.

The seat backrest and seat belts provide the best restraint when the wearer is in a nearly upright position and seat belts are properly positioned on the body. Your seat must be adjusted so that you can correctly fasten your seat belt (> page 48).

Observe the following points:

- Adjust the backrest until your arms are slightly angled when holding the steering wheel.
- Adjust the seat to a comfortable seating position that still allows you to reach the accelerator/brake pedal safely. The position should be as far back as possible with the driver still able to operate the controls properly.
- Adjust the head restraint so that it is as close to the head as possible and the center of the head restraint supports the back of the head at eye level.
- Never place hands under the seat or near any moving parts while a seat is being adjusted.

Failure to do so could result in an accident and/or serious personal injury.

### Warning!



When leaving the vehicle, always remove the SmartKey from the starter switch, take it with you, and lock the vehicle.

Even with the SmartKey removed from the starter switch, the power seats can be operated when the respective door is open. Therefore, do not leave children unattended in the vehicle, or with access to an unlocked vehicle. A child's unsupervised access to a vehicle could result in an accident and/or serious personal injury.

## Adjusting

### Warning!



According to accident statistics, children are safer when properly restrained in the rear seating positions than in the front seating position. Thus, we strongly recommend that children be placed in the rear seats whenever possible. Regardless of seating position, children 12 years old and under must be seated and properly secured in an appropriately sized infant restraint, toddler restraint, or booster seat recommended for the size and weight of the child. For additional information, see “Children in the vehicle” (▷ page 78).

A child’s risk of serious or fatal injuries is significantly increased if the child restraints are not properly secured in the vehicle and/or the child is not properly secured in the child restraint.

### Seat adjustment

The seat adjustment switches are located on the respective front door.



- ① Head restraint height
- ② Seat backrest tilt
- ③ Seat fore and aft adjustment
- ④ Seat cushion tilt
- ⑤ Seat height

**!** When moving the seat, make sure

- there are no items in the footwell or behind the seat
- the cup holder next to the armrest is removed (▷ page 219)
- the cup holder in the front passenger footwell is folded closed (▷ page 220)

Otherwise you could damage the seat and/or cup holders.

**i** The memory function (▷ page 114) lets you store the setting for the seat position together with the settings for the steering wheel and the exterior rear view mirrors.

- ▶ Switch on the ignition (▷ page 39).
- or
- ▶ Open the respective front door.

**Seat fore and aft adjustment**

- ▶ Press the switch forward or backward in direction of arrow ③.

**Seat cushion tilt**

- ▶ Press the switch up or down in direction of arrow ④ until your upper legs are lightly supported.

**Seat backrest tilt**

- ▶ Press the switch forward or backward in direction of arrow ②.

**Seat height**

- ▶ Press the switch up or down in direction of arrow ⑤.

Make sure you have sufficient headroom.

**Head restraint height****Warning!**

Do not drive the vehicle without the seat head restraints. Head restraints are intended to help reduce injuries during an accident.

For your protection, drive only with properly positioned and engaged head restraints.

Adjust the head restraint in such a way that it is as close to the head as possible and the center of the head restraint supports the back of the head at eye level. This will reduce the potential for injury to the head and neck in the event of an accident or similar situation.

- ▶ Press the switch up or down in direction of arrow ①.

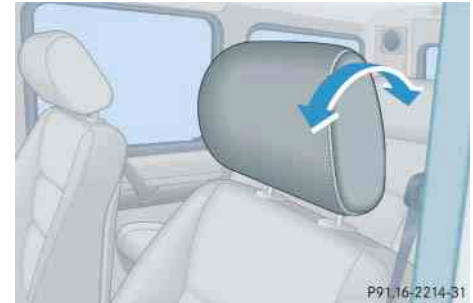
**Head restraint fore and aft adjustment**

Manually adjust the angle of the head restraint.

- ▶ Adjust the head restraint to the desired position by pushing or pulling on the upper edge of the head restraint cushion.

For more information, see “Seats” (▷ page 108).

## Adjusting

### Steering wheel

#### Warning!



Do not adjust the steering wheel while driving. Adjusting the steering wheel while driving could cause the driver to lose control of the vehicle.

When leaving the vehicle, always remove the SmartKey from the starter switch, take it with you, and lock the vehicle.

Even with the SmartKey removed from the starter switch, the steering wheel adjustment feature can be operated when the driver's door is open. Therefore, do not leave children unattended in the vehicle, or with access to an unlocked vehicle. A child's unsupervised access to a vehicle could result in an accident and/or serious personal injury.

**i** The memory function (▷ page 114) lets you store the setting for the steering wheel together with the settings for the seat position and the exterior rear view mirrors.

### Steering wheel adjustment

Make sure that

- you can reach the steering wheel with your arms slightly bent at the elbows,
- you can move your legs freely
- all displays (incl. malfunction and indicator lamps) on the instrument cluster are clearly visible

The steering wheel adjustment stalk is located on the lower left of the steering column.



- ① Adjusting steering wheel, in or out
- ② Adjusting steering wheel, up or down

▶ Switch on the ignition (▷ page 39).

or

▶ Open the driver's door.

**Adjusting steering wheel in or out**

- ▶ Move stalk forward or backward in direction of arrow ①.

**Adjusting steering wheel up or down**

- ▶ Move stalk up or down in direction of arrow ②.

For information on “Heated steering wheel”, see (▷ page 225).

**Easy-entry/exit feature**

This feature allows for easier entry into and exit from the vehicle. When entering and exiting the vehicle, the steering wheel is in its uppermost position.

The easy-entry/exit feature can be activated or deactivated in the Convenience submenu of the control system (▷ page 156).

**Warning!**

You must make sure no one can become trapped or injured by the moving steering wheel when the easy-entry/exit feature is activated.

To stop steering wheel movement, do one of the following:

- Move the steering wheel adjustment stalk (▷ page 44).
- Press one of the stored position buttons or the memory button (▷ page 115).

Do not leave children unattended in the vehicle, or with access to an unlocked vehicle. Children could open the driver’s door and unintentionally activate the easy-entry/exit feature, which could result in an accident and/or serious personal injury.

With the easy-entry/exit feature activated, the steering wheel will return to its last set position when you:

- close the driver’s door with the ignition switched on
- or
- insert the SmartKey into the starter switch with the driver’s door closed

**i** *The last set steering wheel position is stored when*

- *the ignition is switched off (▷ page 39)*
- *the position is stored into memory (▷ page 115)*

With the easy-entry/exit feature activated, the steering wheel tilts upwards when you:

- remove the SmartKey from the starter switch
- or
- open the driver’s door with the SmartKey in starter switch position **0** or **1**

### Adjusting

**i** *If the current position for the steering wheel is in the uppermost tilt position, the steering wheel will no longer be able to move upward when the easy-entry/exit feature is activated.*

#### Warning!



Let the system complete the adjustment procedure before setting the vehicle in motion. All steering wheel adjustment must be completed before setting the vehicle in motion. Driving off with the steering wheel still adjusting could cause the driver to lose control of the vehicle.

### Mirrors

Adjust the interior and exterior rear view mirrors before driving so that you have a good view of the road and traffic conditions.

#### Interior rear view mirror

- ▶ Manually adjust the interior rear view mirror.

For more information, see “Rear view mirrors” (▷ page 177).

### Exterior rear view mirrors

#### Warning!



Exercise care when using the passenger-side exterior rear view mirror. The mirror surface is convex (outwardly curved surface for a wider field of view). Objects in mirror are closer than they appear. Check your interior rear view mirror or glance over your shoulder before changing lanes.

The buttons are located above the exterior lamp switch.

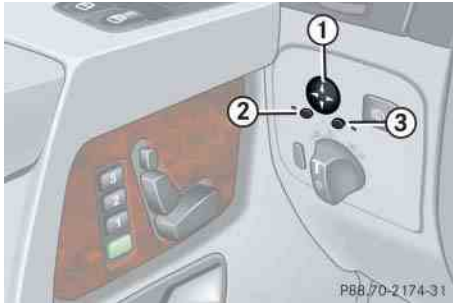

- ① Adjustment button
- ② Driver's side exterior rear view mirror button
- ③ Passenger-side exterior rear view mirror button

- ▶ Switch on the ignition (▷ page 39).
- ▶ Press button ② for the driver's side exterior rear view mirror or button ③ for the passenger-side exterior rear view mirror.
- ▶ Push adjustment button ① up, down, left, or right according to the desired setting.

**!** If an exterior rear view mirror housing is forcibly pushed forward (hit from the rear) or rearward (hit from the front), reposition it by applying firm pressure until it snaps into place. The exterior rear view mirror housing is now properly positioned and you can adjust the mirror in the usual manner.

**i** At low ambient temperatures, the exterior rear view mirrors will be heated automatically.

**i** The memory function (▷ page 114) lets you store the setting for the exterior rear view mirrors together with the settings for the steering wheel and the seat position.

For more information, see "Storing exterior rear view mirror parking position" (▷ page 116).



#### Warning!



Make sure that absolutely no objects are obstructing the pedals' range of movement. Keep the driver's footwell clear of all obstacles. If there are any floor mats or carpets in the footwell, make sure that the pedals still have sufficient clearance.

During sudden driving or braking maneuvers, the objects could get caught between the pedals. You could then no longer brake or accelerate. This could lead to accidents and injury.

#### Fastening the seat belts

#### Warning!



Always fasten your seat belt before driving off. Always make sure your passengers are properly restrained, even those sitting in the rear.

Failure to wear and properly fasten and position your seat belt greatly increases your risk of injuries and their likely severity in an accident. You and your passengers should always wear seat belts.

If you are ever in an accident, your injuries can be considerably more severe without your seat belt properly buckled. Without your seat belt buckled, you are much more likely to hit the interior of the vehicle or be ejected from it. You can be seriously injured or killed.

In the same crash, the possibility of injury or death is lessened if you are wearing your seat belt. The air bags can only provide the protection they were designed to afford if the occupants are using their seat belts (> page 68).

**Warning!**

According to accident statistics, children are safer when properly restrained in the rear seating positions than in the front seating position. Thus, we strongly recommend that children be placed in the rear seats. Regardless of seating position, children 12 years old and under must be seated and properly secured in an appropriately sized infant restraint, toddler restraint, or booster seat recommended for the size and weight of the child. For additional information, see “Children in the vehicle” (▷ page 78).

A child’s risk of serious or fatal injuries is significantly increased if the child restraints are not properly secured in the vehicle and/or the child is not properly secured in the child restraint.

**Warning!**

Never ride in a moving vehicle with the seat backrest in an excessively reclined position as this can be dangerous. You could slide under the seat belt in a collision. If you slide under it, the seat belt would apply force at the abdomen or neck. That could cause serious or even fatal injuries. The seat backrest and seat belt provide the best restraint when the wearer is in a nearly upright position and the seat belt is properly positioned on the body.

**Warning!**

Never let more people ride in the vehicle than there are seat belts available. Make sure everyone riding in the vehicle is correctly restrained with a separate seat belt. Never use a seat belt for more than one person at a time.

**Warning!**

Read and observe the additional warning notices printed in the “Safety and Security” section (▷ page 72) and (▷ page 74).

## Driving

### Front seat belts and rear outer seat belts



- ① Seat belt guide
- ② Latch plate
- ③ Buckle
- ④ Release button

### Fastening seat belts and rear outer seat belts

- ▶ With a smooth motion, pull the seat belt out of seat belt guide ①.
- ▶ Place the shoulder portion of the seat belt across the top of your shoulder and the lap portion across your hips.
- ▶ Push latch plate ② into buckle ③ until it clicks.
- ▶ If necessary, tighten the lap portion to a snug fit by pulling shoulder portion up.

### Opening seat belts and rear outer seat belts

- ▶ Press release button ④.
- ▶ Allow the retractor to completely rewind the seat belt by guiding latch plate ②.

### Rear center seat belt

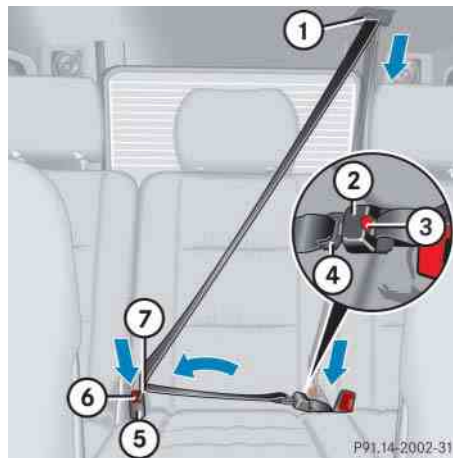

### Overview

- ① Attachment for latch plates
- ② Buckle for fixed latch plate
- ③ Release button for fixed latch plate
- ④ Fixed latch plate
- ⑤ Buckle for free-sliding latch plate
- ⑥ Release button for free-sliding latch plate
- ⑦ Free-sliding latch plate

**Fastening the rear center seat belt**

- ▶ Pull both latch plates ① and ② out of the attachment (▷ page 50).

The seat belt has two latch plates: Plate ① is fixed at the end of the seat belt. Latch plate ② is free-sliding across the seat belt.



- ▶ With a smooth motion, pull the seat belt out of the seat belt outlet.
- ▶ Push fixed latch plate ① into buckle ③ until it clicks.



- ▶ Guide the seat belt at free-sliding latch plate ② across your body. Place the shoulder portion of the seat belt across the top of your shoulder and the lap portion across your hips.
- ▶ Push free-sliding latch plate ② into buckle ④ until it clicks.
- ▶ If necessary, tighten the lap portion to a snug fit by pulling shoulder portion up.

### Driving

#### **Opening the rear center seat belt**

- ▶ Press release button ⑥ on buckle ⑤ for the free-sliding latch plate (▷ page 50).
- ▶ Press release button ③ on buckle ② for the fixed latch plate (▷ page 50).

#### **Storing the rear center seat belt**

- ▶ Allow the retractor to completely rewind the rear center seat belt by guiding latch plate ① (▷ page 51).
- ▶ Guide both latch plates ④ and ⑦ once after the other into attachment ① (▷ page 50).

#### **Warning!**



To help prevent the possibility of injury, always store the rear center seat belt latch plates in the attachment when the rear center seat belt is not in use.

#### **Seat belt outlet height adjustment**

You can adjust the height of the seat belt guide for the following seats:

- Driver's seat
- Front passenger seat
- Rear outer seats

Adjust seat belt so that the shoulder portion is located as close as possible to the middle of the shoulder (it should not touch the neck).



- ① Release button

#### **Raising**

- ▶ Slide the seat belt guide upward in desired position.  
The seat belt guide engages in five different positions.

#### **Lowering**

- ▶ Pull and hold release button ①.
- ▶ Slide the seat belt guide downward in desired position.
- ▶ Let go of release button ①.  
Make sure that the seat belt guide engages into place.

Please comply with the instructions for “Proper use of seat belts” (▷ page 53).

### Proper use of seat belts

- Do not twist the seat belt when fastening.
- Adjust seat belt so that the shoulder portion is located as close as possible to the middle of the shoulder (it should not touch the neck). Never pass the shoulder portion of the seat belt under your arm. For this purpose, you can adjust the height of the seat belt guide (> page 52).
- Position the lap belt as low as possible on your hips (over hip joint) and not across the abdomen.
- Place the seat backrest on adjustable seat backrests in a nearly upright position.
- Never use a seat belt for more than one person at a time.
- Do not fasten a seat belt around a person and another object at the same time. When using a seat belt to secure infant restraints, toddler restraints or children in booster seats, always follow the child seat manufacturer's instructions.
- Check your seat belt periodically during travel to make sure that it is properly positioned.
- Make sure the seat belt is always fitted snugly. Take special care of this when wearing loose clothing.

### Warning!



Do not pass seat belts over sharp edges. They could tear.

Do not allow the seat belt to get caught in the door or in the seat adjustment mechanism. This could damage the seat belt.

Never attempt to make modifications to seat belts. This could impair the effectiveness of the seat belts.

Do not bleach or dye seat belts as this may severely weaken them. In a crash, they may not be able to provide adequate protection.

Damaged seat belts or seat belts that were highly stressed in an accident must be replaced. Contact an authorized Mercedes-Benz Light Truck Center.

### Starting the engine

#### Warning!



Inhalation of exhaust gas is hazardous to your health. All exhaust gas contains carbon monoxide (CO), and inhaling it can cause unconsciousness and possible death.

Do not run the engine in confined areas (such as garage) which are not properly ventilated. If you think that exhaust gas fumes are entering the vehicle while driving, have the cause determined and corrected immediately. If you must drive under these conditions, drive only with at least one window fully open.

### Automatic transmission



#### Gearshift pattern for automatic transmission

- P** Park position with gear selector lever lock
- R** Reverse gear
- N** Neutral position
- D** Drive position

For more information, see “Automatic transmission” (▷ page 162).

### Starting

- ▶ Make sure the gear selector lever is set to park position **P**.
- ▶ Do not depress the accelerator.
- ▶ Turn the SmartKey in the starter switch to position **3** (▷ page 39) and release it again immediately. The engine starts automatically.

For information on turning off the engine, see “Turning off engine” (▷ page 64).

### Starting difficulties

If the SmartKey is left in starter switch position **0** for an extended period of time, it can no longer be turned in the switch. In this case, the steering is locked.

- ▶ To unlock, remove the SmartKey from the starter switch and reinsert.

If the engine does not start as described, carry out the following steps:

- ▶ Turn the SmartKey in the starter switch to position **0** and repeat the starting procedure.

- ▶ Remember that extended starting attempts can drain the battery.
- ▶ Get a jump start (▷ page 399).

If the engine does not start after several starting attempts, there could be a malfunction in the engine electronics or in the fuel supply system.

- ▶ Contact an authorized Mercedes-Benz Light Truck Center or call Roadside Assistance.

## Parking brake

### Warning!



When leaving the vehicle, always remove the SmartKey from the starter switch, take it with you, and lock the vehicle. Do not leave children unattended in the vehicle, or with access to an unlocked vehicle. Children could release the parking brake, which could result in an accident and/or serious personal injury.



- ① Parking brake lever
- ② Release button

- ▶ Pull up slightly on parking brake lever ① and press release button ②.
- ▶ Push parking brake lever ① down to its original position.

The brake warning lamp **BRAKE** (USA only) or **(P)** (Canada only) in the instrument cluster goes out.

## Driving off

- ▶ Depress the brake pedal.  
The gear selector lever lock is released.
- ▶ Move the gear selector lever to drive position **D** or reverse gear **R**.

**!** In order to avoid damage to the transmission:

- Wait for the gear selection process to complete before setting the vehicle in motion.
- Place the gear selector lever in park position **P** or reverse gear **R** only when the vehicle is stopped.
- ▶ Release the brake pedal.
- ▶ Carefully depress the accelerator.

**!** If you hear a warning signal and the message **Release parking brake** appears in the multifunction display when driving off, you have forgotten to release the parking brake.

Release the parking brake (▷ page 55).



### Driving

**i** Once the vehicle is in motion, the automatic central locking system engages and the locking knobs drop down.

The automatic door lock feature can be deactivated (▷ page 155).

You can open a locked door from the inside. Open door only when conditions are safe to do so.

After a cold start, the transmission shifts at a higher engine revolution. This allows the catalytic converter to reach its operating temperature earlier.

#### Warning!



On slippery road surfaces, never downshift in order to obtain braking action. This could result in drive wheel slip and reduced vehicle control. Your vehicle's ABS will not prevent this type of loss of control.

#### Warning!



It is dangerous to shift the gear selector lever out of **P** or **N** if the engine speed is higher than idle speed. If your foot is not firmly on the brake pedal, the vehicle could accelerate quickly forward or in reverse. You could lose control of the vehicle and hit someone or something. Only shift into gear when the engine is idling normally and when your right foot is firmly on the brake pedal.

**!** Do not run cold engine at high engine speed. Running a cold engine at high engine speed may shorten the service life of the engine.

**!** Simultaneously depressing the accelerator pedal and applying the brakes reduces engine performance and causes premature brake and drivetrain wear.

For more information, see “Driving instructions” (▷ page 245).

For information on off-road driving, see “Off-road driving” (▷ page 253).

### Switching on headlamps

#### Low beam headlamps

The exterior lamp switch is located on the dashboard to the left of the steering wheel.



#### Exterior lamp switch

- 1 Off
- 2 Low beam headlamps on

► Turn the exterior lamp switch to position .

The low beam headlamp indicator lamp  in the instrument cluster comes on (▷ page 26).

## High beam

The combination switch is located on the left of the steering column.



### Combination switch

- ① High beam
- ② High beam flasher

- ▶ Push the combination switch in direction of arrow ①.

The high beam headlamp indicator lamp  in the instrument cluster comes on (▷ page 26).

For more information on headlamps, see “Lighting” (▷ page 117).

## Turn signals



The combination switch is located on the left of the steering column.



### Combination switch

- ① Turn signals, right
- ② Turn signals, left

- ▶ Press the combination switch in direction of arrow ① or ②.

The corresponding turn signal indicator lamp  or  in the instrument cluster flashes (▷ page 26).

The combination switch resets automatically after major steering wheel movements.

**i** To signal minor directional changes such as changing lanes, press combination switch only to point of resistance and release. The corresponding turn signals will flash three times.

### Windshield wipers

The combination switch is located on the left of the steering column.



#### Combination switch

- ① Single wipe  
Wiping with windshield washer fluid
  - ② Switching on windshield wipers
- ▶ Switch on the ignition (▷ page 39).

**!** Do not operate the windshield wipers when the windshield is dry. Dust that accumulates on a windshield might scratch the glass and/or damage the wiper blades when wiping occurs on a dry windshield. If it is necessary to operate the windshield wipers in dry weather conditions, always operate the windshield wipers with windshield washer fluid (▷ page 59).

**!** If anything blocks the windshield wipers (leaves, snow, etc.), switch them off immediately.

- For safety reasons, stop the vehicle in a safe location, turn off the engine and remove the SmartKey from the starter switch before attempting to remove any blockage.
- Remove blockage.
- Turn the windshield wipers on again.

If the windshield wipers fail to function at all with the combination switch in position I,

- set the combination switch to the next higher wiper speed
- have the windshield wipers checked at the nearest authorized Mercedes-Benz Light Truck Center.

### Switching on windshield wipers

▶ Turn the combination switch to the desired position depending on the intensity of the rain.

- 0 Windshield wipers off
- I Intermittent wiper
- II Normal wiper speed
- III Fast wiper speed

## Intermittent wiping

Only switch on intermittent wiping under wet weather conditions or in the presence of precipitation.

When you select intermittent wiping, the rain sensor is activated. The rain sensor automatically sets a suitable wiping interval depending on the wetness of the sensor surface.

**!** Do not leave windshield wipers in intermittent setting when the vehicle is taken to an automatic car wash or during windshield cleaning. Windshield wipers will operate in the presence of water sprayed on the windshield, and windshield wipers may be damaged as a result.

- ▶ Turn the combination switch to position **I**.

After the initial wipe, pauses between wipes are automatically controlled by the rain sensor.

**i** *Intermittent wiping is interrupted when the vehicle is at a standstill and a front door is opened. This protects persons getting into or out of the vehicle from being sprayed.*

*Intermittent wiping will be continued when all doors are closed and*

- *the gear selector lever is in drive position **D** or reverse gear **R***
- *the wiper setting is changed using the combination switch*

## Single wipe

- ▶ Press the combination switch briefly in direction of arrow ① to the resistance point.

The windshield wipers wipe one time without washer fluid.

## Wiping with windshield washer fluid

- ▶ Push the combination switch in direction of arrow ① past the resistance point.

The windshield wipers operate with washer fluid.

**i** *To prevent smears on the windshield, or noisy/chattering wiper blades, wipe with windshield washer fluid every now and then even when it is raining.*

For information on filling up the washer reservoir, see “Windshield/rear window washer system and headlamp cleaning system” (▷ page 275).

## Driving

### Rear window wiper/washer

The rear window wiper/washer switch is located on the upper part of the center console.



- ① Intermittent wiper
- ② Indicator lamp
- ③ Rear window washer system

**i** The rear window wiper engages automatically when the gear selector lever is in reverse gear **R** with the windshield wipers switched on.

- ▶ Switch on the ignition (▷ page 39).

### Activating intermittent wiper

- ▶ Press switch ①.  
Indicator lamp ② comes on.  
Intermittent wiper is activated.

### Deactivating intermittent wiper

- ▶ Press switch ① once more.  
Indicator lamp ② goes out.  
Intermittent wiper is deactivated.

### Wiping with windshield washer fluid

- ▶ Press and hold switch ③.

The wiper operates with washer fluid.

The rear window is wiped for a further 5 seconds after switch ③ is released.

For information on filling up the washer reservoir, see “Windshield/rear window washer system and headlamp cleaning system” (▷ page 275).

## Problems while driving

### The engine runs erratically and misfires

- An ignition cable may be damaged.
- The engine electronics may not be operating properly.
- Unburned gasoline may have entered the catalytic converter and damaged it.
- ▶ Give very little gas.
- ▶ Have the problem repaired at an authorized Mercedes-Benz Light Truck Center as soon as possible.

### The coolant temperature is above 248°F (120°C)

The coolant is too hot and is no longer cooling the engine.

- ▶ Stop the vehicle in a safe location as soon as possible and turn off the engine. Allow engine and coolant to cool off.
- ▶ Check the coolant level and add coolant if necessary (▷ page 274).

**i** *Excessive coolant temperatures trigger a warning message in the multifunction display (▷ page 348).*

### In case of accident

If the vehicle is leaking fuel:

- ▶ Do not start the engine under any circumstances.
- ▶ Notify local fire and/or police authorities.

If the extent of the damage cannot be determined:

- ▶ Contact an authorized Mercedes-Benz Light Truck Center or call Roadside Assistance.

If no damage can be determined on the

- major assemblies
- fuel system
- engine mount:
- ▶ Start the engine in the usual manner.

### Parking and locking

You have now completed your first drive. You have properly stopped and parked your vehicle. End your drive as follows.

#### Warning!



With the engine not running, there is no power assistance for the brake and the steering system. In this case, it is important to keep in mind that a considerably higher degree of effort is necessary to brake and steer the vehicle.

#### Warning!



Do not park this vehicle in areas where combustible materials such as grass, hay or leaves can come into contact with the hot exhaust system, as these materials could be ignited and cause a vehicle fire.

To reduce the risk of personal injury or damage to the vehicle drivetrain as a result of vehicle movement, before turning off the engine and leaving the vehicle always:

- Keep right foot on brake pedal.
- Pull the parking brake lever up as many notches as possible.
- Move the gear selector lever to park position **P**.
- Slowly release brake pedal.
- When parked on an incline, turn front wheels towards the road curb.
- Turn the SmartKey in the starter switch position **0** and remove.
- Take the SmartKey with you and lock vehicle when leaving.

### Parking brake

#### Warning!



Engaging the parking brake while the vehicle is in motion can cause the rear wheels to lock up. You could lose control of the vehicle and cause an accident. In addition, the vehicle's brake lights do not light up when the parking brake is engaged.



① Parking brake lever

- ▶ Pull parking brake lever ① up as many notches as possible.

When the ignition is switched on or the engine is running, the brake warning lamp **BRAKE** (USA only) or **(P)** (Canada only) in the instrument cluster comes on.

**Warning!**



Getting out of your vehicle with the gear selector lever not fully engaged in park position **P** is dangerous. Also, when parked on an incline, park position **P** alone may not prevent your vehicle from moving, possibly hitting people or objects.

Always set the parking brake in addition to shifting to park position **P** (▷ page 164).

When parked on an incline, turn front wheels towards the road curb.

**Warning!**



When leaving the vehicle, always remove the SmartKey from the starter switch, take it with you, and lock the vehicle. Do not leave children unattended in the vehicle, or with access to an unlocked vehicle. Children could release the parking brake and/or move the gear selector lever from park position **P**, either of which could result in an accident and/or serious personal injury.



### Parking and locking

#### Switching off headlamps

- ▶ Turn the exterior lamp switch to **0** (▷ page 56).

For more information, see “Lighting” (▷ page 117).

#### Turning off engine

- ▶ Move the gear selector lever to park position **P**.

#### Warning!



Do not turn off the engine before the vehicle has come to a complete stop. With the engine not running, there is no power assistance for the brake and steering systems. In this case, it is important to keep in mind that a considerably higher degree of effort is necessary to brake and steer the vehicle.

Apply the parking brake (▷ page 62).

**i** Always set the parking brake in addition to shifting to park position **P** (▷ page 164).

*On slopes, turn the front wheels towards the road curb.*

- ▶ Turn SmartKey in the starter switch to position **0**.
- ▶ Remove the SmartKey from the starter switch.

The immobilizer is activated.

**i** The SmartKey can only be removed from the starter switch with the gear selector lever in park position **P** and the SmartKey in starter switch position **0**.

#### Releasing seat belts

- ▶ Press seat belt release button (▷ page 50).

Allow the retractor to completely rewind the seat belt by guiding latch plate.

**!** Make sure the seat belt retracts fully so that the seat belt and/or latch plate cannot get caught or pinched in the door or in the seat mechanism. This can damage the seat belt and impair the effectiveness of the seat belt, and/or cause damage to the door and/or door trim panel. Such damage is not covered by the Mercedes-Benz Limited Warranty.

*Damaged seat belts must be replaced. Contact an authorized Mercedes-Benz Light Truck Center.*

## Locking

### Warning!



To prevent possible personal injury, always keep hands and fingers away from the door openings when closing the doors. Be especially careful when small children are around.

Before closing doors, make sure there is no possibility of someone getting caught in a door during closing.

### Warning!



When leaving the vehicle, always remove the SmartKey from the starter switch, take it with you, and lock the vehicle. Do not leave children unattended in the vehicle, or with access to an unlocked vehicle. A child's unsupervised access to a vehicle could result in an accident and/or serious personal injury.

- ▶ Exit the vehicle and close all doors and the tailgate.

**i** *If you hear a warning signal you have forgotten to switch off the headlamps before opening the driver's door.*

*In addition the message Switch off lights appears in the multifunction display.*

*Switch off the headlamps.*

**!** *Failure to switch off the headlamps when leaving the vehicle may result in a discharged battery.*

- ▶ Press lock button  on the SmartKey (▷ page 38).

With the hood, tailgate and all doors closed:

- All turn signal lamps flash three times.
- The locking knobs in the doors move down.
- The anti-theft alarm system is armed.

For more information, see “Locking and unlocking” (▷ page 100).



**Occupant safety**

**Panic alarm**

**Driving safety systems**

**Anti-theft systems**



## Occupant safety

In this section you will learn the most important facts about the restraint systems of the vehicle.

- Seat belts (▷ page 74)
- Child restraints (▷ page 84)
- Lower Anchors and Tethers for Children (LATCH) (▷ page 83)

Additional protection potential provide

- Supplemental Restraint System (SRS) with
  - Air bags (▷ page 70)
  - Air bag control unit (with crash sensors)
  - Emergency Tensioning Device (ETD) for seat belts (▷ page 78)

Air bag system components with

- Front passenger front air bag off indicator lamp (▷ page 81)
- BabySmart™ air bag deactivation system (▷ page 81)

Although independent systems, their protective functions work in conjunction with each other.

**i** For information on infants and children traveling with you in the vehicle and restraint systems for infants and children, see “Children in the vehicle” (▷ page 78).

The **SRS** indicator lamp in the instrument cluster (▷ page 27) comes on:

- for about 4 seconds when you turn the SmartKey in the starter switch to position **1**.
- for about 4 seconds when you start the engine by turning the SmartKey.

**i** The **SRS** indicator lamp remains lit if the SmartKey is turned to position **2** and left there. The indicator lamp will go out when you start the engine.

The SRS components are in operational readiness if the **SRS** indicator lamp is not lit when the engine is running.

A malfunction in the system has been detected if the **SRS** indicator lamp:

- fails to go out after approximately 4 seconds.
- does not come on at all.
- comes on after the engine was started or while driving.

For more information, see “Practical hints” (▷ page 334).

**Warning!**

Modifications to or work improperly conducted on restraint systems (such as seat belts and anchors, emergency tensioning devices, seat belt force limiters or air bags) or their wiring, as well as tampering with interconnected electronic systems, can lead to the restraint systems no longer functioning as intended.

Air bags or emergency tensioning devices, for example, could deploy inadvertently or fail to deploy in accidents although the deceleration threshold for air bag deployment is exceeded. Therefore, never modify the restraint systems. Do not tamper with electronic components or their software.

**Warning!**

In the event that the **SRS** indicator lamp comes on during driving or does not come on at all, the SRS self-check has detected a malfunction. For your safety, we strongly recommend that you visit an authorized Mercedes-Benz Light Truck Center immediately to have the system checked; otherwise the SRS may not deploy when needed in an accident, which could result in serious or fatal injury, or it might deploy unexpectedly and unnecessarily which could also result in injury.

In addition, improper work on the SRS creates a risk of rendering the SRS inoperative or causing unintended air bag deployment. Work on the SRS must therefore only be performed by qualified technicians. Contact an authorized Mercedes-Benz Light Truck Center.

If it is necessary to modify an air bag system to accommodate a person with disabilities, contact a local authorized Mercedes-Benz Light Truck Center or call our Customer Assistance Center at 1-800-FOR-MERCEdes (1-800-367-6372) for details.

## Occupant safety

### Air bags

#### Warning!



Air bags are designed to reduce the potential of injury and fatality in certain frontal impacts (front air bags), or side impacts (window curtain air bags). However, no system available today can completely eliminate injuries and fatalities.

The deployment of the air bags temporarily releases a small amount of dust from the air bags. This dust, however, is neither injurious to your health, nor does it indicate a fire in the vehicle. The dust might cause some temporary breathing difficulty for people with asthma or other breathing trouble. To avoid this, you may wish to get out of the vehicle as soon as it is safe to do so. If you have any breathing difficulty but cannot get out of the vehicle after the air bag inflates, then get fresh air by opening a window or door.

#### Warning!



The service life of the passenger front air bag extends to the date indicated on the label located on the driver side B pillar. To provide continued reliability after that date, they should be inspected at an authorized Mercedes-Benz Light Truck Center at that time and replaced when necessary.

#### Warning!



To reduce the risk of injury when the front air bags inflate, it is very important for the driver and front passenger to always be in a properly seated position and to wear their respective seat belts.

For maximum protection in the event of a collision always be in normal seated position with your back against the seat backrest. Fasten your seat belt and make sure it is properly positioned on your body (▷ page 50).

Since the air bag inflates with considerable speed and force, a proper seating and hands on steering wheel position will help to keep you at a safe distance from the air bag. Occupants who are unbelted, out of position or too close to the air bag can be seriously injured or killed by an air bag as it inflates with great force in the blink of an eye:

- Sit properly belted in a position that is as upright as possible with your back against the seat backrest.

- Adjust the driver's seat as far as possible rearward, still permitting proper operation of vehicle controls. The distance from the center of the driver's breastbone to the center of the air bag cover on the steering wheel must be at least 10 inches (25 cm) or more. You should be able to accomplish this by a combination of adjustments to the seat and steering wheel. If you have any problems, please see an authorized Mercedes-Benz Light Truck Center.
- Do not lean with your head or chest close to the steering wheel or dashboard.
- Keep hands on the outside of steering wheel rim. Placing hands and arms inside the rim can increase the risk and potential severity of hand/arm injury when driver's front air bag inflates.
- Adjust the front passenger seat as far as possible rearward from the dashboard when the seat is occupied.

- Always sit as upright as possible, properly use the seat belts and appropriate size infant or child restraint system.
- Children 12 years old and under must never ride in the front seat, except in a Mercedes-Benz authorized BabySmart™ compatible child seat, which operates with the BabySmart™ system installed in the vehicle to deactivate the passenger front air bag when it is properly installed. Otherwise they will be struck by the air bag when it inflates in a crash. If this happens, serious or fatal injury will result.

Failure to follow these instructions can result in severe injuries to you or other occupants.

If you sell your vehicle, it is important that you make the buyer aware of this safety information. Be sure to give the buyer this Operator's Manual.

### Warning!



Accident research shows that the safest place for children in an automobile is in the rear seat. Should you choose to place a child 12 years old or under in the front passenger seat of your vehicle, you must properly use a BabySmart™ child restraint which will turn off the passenger front air bag.

To help avoid the possibility of injury, please follow these guidelines:

- (1) Always sit as upright as possible, properly use the seat belts and use an appropriately sized infant or child restraint system for all children 12 years old or under.
- (2) Always wear seat belts properly.



## Occupant safety

**i** Air bags are designed to deploy only in certain frontal impacts (front air bags) and in side impacts (window curtain air bags) which exceed preset thresholds. Only during these events will they provide their supplemental protection.

The driver and passenger should always wear their seat belts. Otherwise it is not possible for the air bags to provide their supplemental protection.

In case of other types of impacts and impacts below air bag deployment thresholds, air bags will not deploy. The driver and passenger will then be protected to the extent possible by a properly fastened seat belt. A properly fastened seat belt is also needed to provide the best possible protection in a rollover.

We caution you not to rely on the presence of the air bags in order to avoid wearing your seat belt.

It is important to your safety and that of your passenger that you replace deployed air bags and repair any malfunctioning air bags to make sure the vehicle will continue to provide supplemental crash protection for occupants.

### Safety guidelines for the seat belt, emergency tensioning device and air bag

#### Warning!



- Damaged seat belts or seat belts that were highly stressed in an accident must be replaced and their anchoring points must also be checked. Use only seat belts installed or supplied at an authorized Mercedes-Benz Light Truck Center.
- Air bags and Emergency Tensioning Devices (ETDs) are designed to function on a one-time-only basis. An air bag or ETD that has deployed must be replaced.
- Do not pass seat belts over sharp edges. They could tear.
- Do not make any modification that could change the effectiveness of the seat belts.

- Do not bleach or dye seat belts as this may severely weaken them. In a crash they may not be able to provide adequate protection.
- No modifications of any kind may be made to any components or wiring of the SRS. This includes changing or removing any component or part of the SRS, the installation of additional trim material, badges, etc. over the steering wheel hub, front passenger front air bag cover, outboard sides of the front seat backrests, door trim panels, or door frame trims, and installation of additional electrical/electronic equipment on or near SRS components and wiring. Keep area between air bags and occupants free from objects (e.g. packages, purses, umbrellas, etc.).
- Air bag system components will be hot after an air bag has inflated. Do not touch.
- Never place your feet on the instrument panel, dashboard, or on the seat. Always keep both feet on the floor in front of the seat.

- In addition, improper repair work on the SRS creates a risk of rendering the SRS inoperative or causing unintended air bag deployment. Work on the SRS must therefore only be performed by qualified technicians. Contact an authorized Mercedes-Benz Light Truck Center.
- For your protection and the protection of others, when scrapping the air bag unit or emergency tensioning device, our safety instructions must be followed. These instructions are available from any authorized Mercedes-Benz Light Truck Center.
- Given the considerable deployment speed and the textile structure of the air bags, there is the possibility of abrasions or other injuries resulting from air bag deployment.

When you sell your vehicle we strongly urge you to give notice to the subsequent owner that it is equipped with an SRS by alerting them to the applicable section in the Operator's Manual.

### Front air bags



- ① Driver air bag
- ② Passenger front air bag

Driver and passenger front air bags are deployed:

- in the event of certain frontal impacts
- if impact exceeds a preset deployment threshold

The air bags will not deploy in impacts which do not exceed the system's deployment thresholds. You will then be protected by the fastened seat belts.

The passenger front air bag will only be deployed if:

- the front passenger seat is occupied
- the  indicator lamp in the center console is not lit (▷ page 81)
- the impact exceeds a preset deployment threshold

**!** Do not place objects heavier than 20 lbs (9 kg) on the front passenger seat. This could cause the passenger front air bag to deploy in a crash which exceeds the system's deployment threshold.

## Occupant safety

### Window curtain air bags

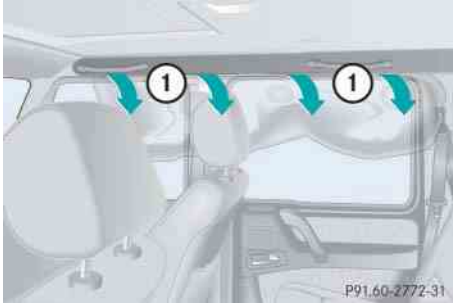

#### ① Window curtain air bag

The window curtain air bags are deployed:

- on the impacted side of the vehicle
- in impacts exceeding a preset deployment threshold
- independently of the front air bags

The window curtain air bags are not deployed in impacts which do not exceed the system's deployment threshold.

### Seat belts

The use of seat belts and infant and child restraint systems is required by law in all 50 states, the District of Columbia, the U.S. territories and all Canadian provinces.

Even where this is not the case, all vehicle occupants should have their seat belts fastened whenever the vehicle is in motion.

For more information, see “Fastening the seat belts” (▷ page 48).

**i** For information on infants and children traveling with you in the vehicle and restraint systems for infants and children, see “Children in the vehicle” (▷ page 78).

### Warning!



Always fasten your seat belt before driving off. Always make sure your passengers are properly restrained, even those sitting in the rear.

Failure to wear and properly fasten and position your seat belt greatly increases your risk of injuries and their likely severity in an accident. You and your passengers should always wear seat belts.

If you are ever in an accident, your injuries can be considerably more severe without your seat belt properly buckled. Without your seat belt buckled, you are much more likely to hit the interior of the vehicle or be ejected from it. You can be seriously injured or killed.

In the same crash, the possibility of injury or death is lessened if you are properly wearing your seat belt. Air bags can only protect as they are designed if the occupants are properly wearing their seat belts.

**Warning!**

Never ride in a moving vehicle with the seat backrest in an excessively reclined position as this can be dangerous. You could slide under the seat belt in a collision. If you slide under it, the seat belt would apply force at the abdomen or neck. That could cause serious or even fatal injuries. The seat backrest and seat belt provide the best restraint when the wearer is in a nearly upright position and the seat belt is properly positioned on the body.

**Warning!**

Never let more people ride in the vehicle than there are seat belts available. Make sure everyone riding in the vehicle is correctly restrained with a separate seat belt. Never use a seat belt for more than one person at a time.

**Warning!**

Damaged seat belts or seat belts that were highly stressed in an accident must be replaced and their anchoring points must also be checked.

Only use seat belts which have been approved by Mercedes-Benz.

Do not make any modifications to the seat belts. This can lead to unintended activation of the ETDs or to their failure to activate when necessary.

Do not bleach or dye seat belts as this may severely weaken them. In a crash, they may not be able to provide adequate protection.

Have all work carried out only by qualified technicians. Contact an authorized Mercedes-Benz Light Truck Center.

## Occupant safety

### Warning!



#### USE SEAT BELTS PROPERLY



- Seat belts can only work when used properly. Never wear seat belts in any other way than as described in this section, as that could result in serious injuries in case of an accident.
- Each occupant should wear their seat belt at all times, because seat belts help reduce the likelihood of and potential severity of injuries in accidents, including rollovers. The integrated restraint system includes SRS (driver air bag, passenger front air bag, window curtain air bags for side windows), and ETD (seat belt emergency tensioning device). The system is designed to enhance the protection offered to properly belted occupants in certain frontal (front air bags and ETD) and side (window curtain air bags and ETD) impacts which exceed preset deployment thresholds.
- Never wear the shoulder belt under your arm, against your neck or off your shoulder. In a frontal crash, your body would move too far forward. That would increase the chance of head and neck injuries. The shoulder belt would also apply too much force to the ribs or abdomen, which could severely injure internal organs such as your liver or spleen.
- Never wear seat belts over rigid or breakable objects in or on your clothing, such as eyeglasses, pens, keys, etc., as these might cause injuries.
- Position the lap belt as low as possible on your hips and not across the abdomen. If the lap belt is positioned across your abdomen, it could cause serious injuries in a crash.
- Never use a seat belt for more than one person at a time. Do not fasten a seat belt around a person and another person or other objects.
- Seat belts should not be worn twisted. In a crash, you wouldn't have the full width of the seat belt to manage impact forces. The twisted seat belt against your body could cause injuries.
- Pregnant women should also always use a lap-shoulder belt. The lap belt portion should be positioned as low as possible on the hips to avoid any possible pressure on the abdomen.
- Never place your feet on the instrument panel, dashboard or on the seat. Always keep both feet on the floor in front of the seat.
- When using a seat belt to secure infant restraints, toddler restraints or children in booster seats, always follow the child seat manufacturer's instructions.

### Enhanced seat belt reminder system

When the engine is started, the seat belt telltale  will always illuminate for 6 seconds to remind you and your passengers to fasten your seat belts.

If the driver's seat belt is not fastened when the engine is started, an additional warning chime will also sound for a maximum of 6 seconds or until the driver's seat belt is fastened.

If after these 6 seconds the driver's or the front passenger's seat belt (with the front passenger seat occupied) is not fastened with front doors closed,

- the seat belt telltale  remains illuminated for as long as either the driver's or front passenger's seat belt is not fastened.
- and if the vehicle speed once exceeds 15 mph (25 km/h), the seat belt telltale  starts flashing and a warning chime sounds with increasing intensity for a maximum of 60 seconds or until the driver's and the front passenger's seat belt are fastened. If you and/or your passenger release the seat belt during driving, the seat belt telltale  starts flashing and a warning chime sounds as described before.

If the driver's or the front passenger's seat belt remains unfastened after 60 seconds, the warning chime stops sounding, the seat belt telltale  stops flashing but continues to be illuminated.

After a vehicle standstill the warning chime is reactivated and the seat belt telltale  is flashing again if the vehicle speed once exceeds 15 mph (25 km/h).

The seat belt telltale  will only go out if both the driver's and the front passenger's seat belt (with the front passenger seat occupied) are fastened, or the vehicle is standing still and a front door is opened.

For more information, see "Practical hints" (> page 332).

## Occupant safety

### Emergency Tensioning Device (ETD), seat belt force limiter

The seat belts for the front and rear outer seats are equipped with emergency tensioning devices and seat belt force limiters.

The ETD is designed to activate in the following cases:

- in frontal or rear-end impacts exceeding the system deployment threshold
- if the restraint systems are operational and functioning correctly, see **SRS** indicator lamp (▷ page 68)

**i** *The ETDs for the front seats will only activate if the respective front seat belt is fastened (latch plate properly inserted into buckle).*

*The ETDs for the rear outer seats will activate with or without the respective seat belt fastened.*

When activated, emergency tensioning devices remove slack from the seat belts in such a way that the seat belts fit more snugly against the body. Seat belt force limiters reduce the force exerted by the seat belts on occupants during a crash.

#### Warning!



An Emergency Tensioning Device (ETD) that was activated must be replaced.

When disposing of emergency tensioning device, our safety instructions must be followed. These are available at any authorized Mercedes-Benz Light Truck Center.

**!** *Do not place objects heavier than 20 lbs (9 kg) on the front passenger seat. This could cause the passenger front air bag and, with the seat belt fastened to secure the object, the ETD on the front passenger side to deploy in a crash which exceeds the system's deployment threshold.*

### Children in the vehicle

If an infant or child is traveling with you in the vehicle:

- ▶ Secure the child using an infant or child restraint appropriate to the age and size of the child.
- ▶ Make sure the infant or child is properly secured at all times while the vehicle is in motion.

**Warning!**

Do not leave children unattended in the vehicle, even if they are secured in a child restraint system. The children could

- injure themselves on parts of the vehicle
- be seriously or fatally injured through excessive exposure to extreme heat or cold

Do not expose the child restraint system to direct sunlight. The child restraint system's metal parts, for example, could become very hot, and the child could be burned on these parts.

If children open a door, they could

- injure other persons
- get out of the car and injure themselves or be injured by following traffic

Do not carry heavy or hard objects in the passenger or cargo compartment unless they are firmly secured in place. For more information, see “Loading” (▷ page 206) and “Useful features” (▷ page 215).

Unsecured or improperly positioned cargo increases a child's risk of injury in the event of

- strong braking maneuvers
- sudden changes of direction
- an accident

**Infant and child restraint systems**

Only use a BabySmart™ compatible child restraint for the front passenger seat in this vehicle.

We recommend all infants and children be properly restrained at all times while the vehicle is in motion.

All lap-shoulder belts except the driver's seat belt and the rear center seat belt have special seat belt retractors for secure fastening of child restraints.

To fasten a child restraint, follow child restraint instructions for mounting. Then pull the shoulder belt out completely and let it retract. During seat belt retraction, a ratcheting sound can be heard to indicate that the special seat belt retractor is activated. The seat belt is now locked. Push down on child restraint to take up any slack.



### Occupant safety

To deactivate, release seat belt buckle and let seat belt retract completely. The seat belt can again be used in the usual manner.

#### Warning!



Never release the seat belt buckle while the vehicle is in motion, since the special seat belt retractor will be deactivated.

**i** For information on child seats with mounting fittings for tether anchorages, see “Installation of infant and child restraint systems” (▷ page 84).

For information on LATCH-type child seat anchors, see (▷ page 83).

The use of infant or child restraints is required by law in all 50 states, the District of Columbia, the U.S. territories and all Canadian provinces.

Infants and small children should be seated in an appropriate infant or child restraint system properly secured in accordance with the manufacturer's instructions for the child restraint, that complies with U.S. Federal Motor Vehicle Safety Standards 213 and 225 and Canadian Motor Vehicle Safety Standards 213 and 210.2.

A statement by the child restraint manufacturer of compliance with these standards can be found on the instruction label on the restraint and in the instruction manual provided with the restraint.

When using any infant or child restraint system, make sure to carefully read and follow all manufacturer's instructions for installation and use.

Please read and observe warning labels affixed to inside of vehicle and to infant or child restraints.

#### Warning!



Children 12 years old and under must never ride in the front seat, except in a Mercedes-Benz authorized BabySmart™ compatible child seat, which operates with the BabySmart™ system installed in the vehicle to deactivate the passenger front air bag when it is properly installed. Otherwise they will be struck by the air bag when it inflates in a crash. If this happens, serious or fatal injury can result.

According to accident statistics, children are safer when properly restrained in the rear seating positions than in the front seating positions. Infants and small children must ride in back seats and be seated in an appropriate infant or child restraint system, which is properly secured with the vehicle's seat belt and top tether strap, or secured via lower anchors and top tether strap, fully in accordance with the child seat manufacturer's instructions.

Infants and small children should never share a seat belt with another occupant. During an accident, they could be crushed between the occupant and seat belt.

A child's risk of serious or fatal injuries is significantly increased if the child restraints are not properly secured in the vehicle and the child is not properly secured in the child restraint.

Children too big for child restraint systems must ride in back seats using regular seat belts. Position shoulder belt across chest and shoulder, not face or neck.

A booster seat may be necessary to achieve proper seat belt positioning for children from 41 lbs until they reach a height where a lap/shoulder belt fits properly without a booster.

When the child restraint is not in use, remove it from the vehicle or secure it with the seat belt to prevent the child restraint from becoming a projectile in the event of an accident.

Do not leave children unattended in the vehicle; even if the children are secured in a child restraint system. Unsupervised children in a child restraint system may use vehicle equipment and may cause an accident and/or serious personal injury.

### BabySmart™ air bag deactivation system

The  indicator lamp is located on the upper part of the center console.



① Front passenger front air bag off indicator lamp

### Occupant safety

Special BabySmart™ compatible child seats, designed for use with the Mercedes-Benz system and available at any authorized Mercedes-Benz Light Truck Center are required for use with the BabySmart™ air bag deactivation system. With the special child seat properly installed, the passenger front air bag will not deploy.

The  indicator lamp will be illuminated, except with the SmartKey removed or in starter switch position 0.

 *The system does not deactivate the emergency tensioning device.*

#### Self-test BabySmart™ without special child seat installed

After turning the SmartKey in the starter switch to position 1 or 2, the  indicator lamp comes on for approximately 6 seconds and then goes out.

If the  indicator lamp should not come on or is continuously lit, the system is not functioning. You must see an authorized Mercedes-Benz Light Truck Center before seating any child on the front passenger seat.

For more information, see “Practical hints” section (▷ page 337).

#### Warning!







The BabySmart™ air bag deactivation system will ONLY work with a special child seat designed to operate with it. It will not work with child seats which are not BabySmart™ compatible.

Never place anything between seat cushion and child seat (e.g. pillow), since it reduces the effectiveness of the deactivation system. The bottom of the child seat must make full contact with the passenger seat cushion. An incorrectly mounted child seat could cause injuries to the child in case of an accident, instead of protecting the child.

Follow the manufacturer's instructions for installation of special child seats.

**Warning!**

When using a BabySmart™ compatible child seat on the front passenger seat, the passenger front air bag will not deploy only if the  indicator lamp (▷ page 81) remains illuminated.

Make sure to check the  indicator lamp every time you use the special system child seat. Should the  indicator lamp go out while the restraint is installed, please check installation. If the  indicator lamp remains out, do not use the BabySmart™ restraint to transport children on the front passenger seat until the system has been repaired.

**Warning!**

Do not place powered-on laptops, cell phones, electronic tags such as those used in ski passes and like electronic devices on the front passenger seat. Signals from such devices may interfere with the BabySmart™ system. Such signal interference may cause the  indicator lamp (▷ page 81) not to come on during self-test or be continuously lit, indicating that the system is not functioning.

**Child seat anchors – LATCH type**

This vehicle is equipped with two LATCH- (Lower Anchors and Tethers for Children) type anchors (at each of the outer rear seats) for installation of a LATCH-type child seat with matching mounting fittings.

**Warning!**

Children too big for child restraint systems must ride in seats using regular seat belts. Position shoulder belt across chest and shoulder, not face or neck.

A booster seat may be necessary to achieve proper seat belt positioning for children from 41 lbs until they reach a height where a lap/shoulder belt fits properly without a booster.



## Occupant safety

▷▷ Install child seat according to manufacturer's instructions.

The child seat must be firmly attached to the right and left side anchors ①.

An incorrectly mounted child seat may come loose during an accident which could result in serious injury or death to the child.

Damaged or impact damaged child seats or child seat mounting fittings must be replaced.

Do not leave children unattended in the vehicle, even if the children are secured in a child restraint system.

The LATCH-type anchors are located between the seat cushion and the seat backrest.

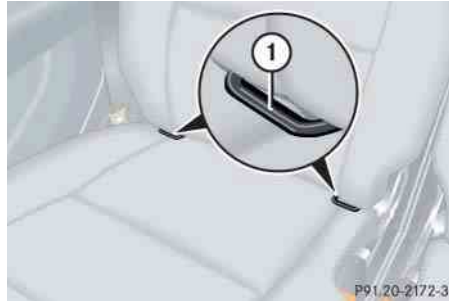

① Anchors

▶ Install child seat according to the manufacturer's instructions.

**i** With a child seat installed in the left rear seat, the seat belt for the center seat occupied by a passenger must operate freely.

**i** Non-LATCH type child seats may also be used and can be installed using the vehicle's seat belt system. Install child seat according to the manufacturer's instructions.

## Installation of infant and child restraint systems

▶ Remove the cargo compartment cover blind, if installed (▷ page 214).

▶ Remove the partition net\*, if so equipped and installed (▷ page 210).

Anchorage rings for installation of top tether straps are located on the floor behind each rear seat.

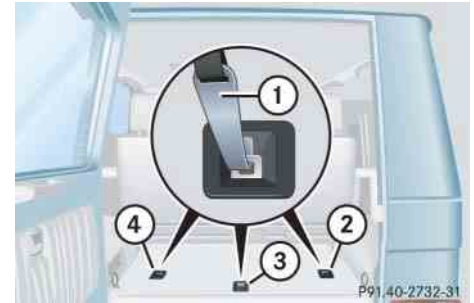

① Hook

② Anchorage ring for rear right side seat

③ Anchorage ring for rear center seat

④ Anchorage ring for rear left side seat

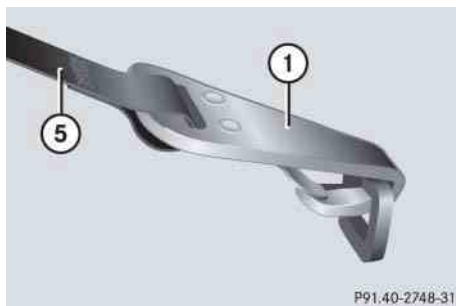

### Hook fastened to respective anchorage ring

- ① Hook
- ⑤ Top tether strap

- ▶ Guide top tether strap ⑤ between head restraint and top of seat backrest.
- ▶ Securely fasten hook ①, which is part of top tether strap ⑤, to respective anchorage ring ②, ③, or ④.

**i** For safety, make sure hook ① has attached to respective anchorage ring beyond the safety catch, as shown in the illustration above.

Make sure

- the top tether strap is not twisted
- the head restraint is installed and positioned such that the top tether strap can pass freely between the head restraint and top of the seat backrest

Once the top tether anchorage hook is attached, the child restraint itself can be secured. Secure child restraint and tighten the top tether strap according to the child restraint manufacturer's instructions.

### Warning!



Use only the described anchorage rings for the respective child seat. Other lashing eyelets could tear in case of an accident.

Make sure

- the fastening straps are not crossed or twisted.
- the hook is properly attached and is closed.

## Occupant safety

### Blocking of rear door window operation

With the override switch you can disable the rear side window switches in the rear doors.

#### Warning!



Activate the override switch when children are riding in the back seats of the vehicle. The children may otherwise injure themselves, e.g. by becoming trapped in the window opening.

When leaving the vehicle, always remove the SmartKey from the starter switch, take it with you, and lock the vehicle. Do not leave children unattended in the vehicle, or with access to an unlocked vehicle. A child's unsupervised access to a vehicle could result in an accident and/or serious personal injury.

The override switch is located on the driver's door control panel.

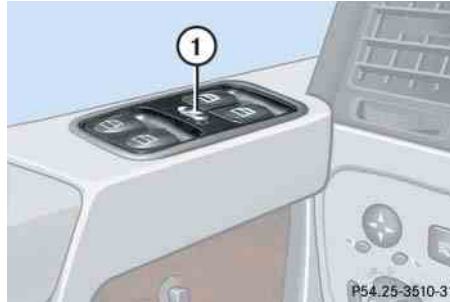

① Override switch

For more information on power windows, see “Power windows” (▷ page 192).

### Disabling

- ▶ Slide override switch ① to the right.

Symbol  becomes visible.

The rear door windows can no longer be operated using the switches located in the rear doors.

**i** *Operating the rear door windows using the switches located on the door control panel of the driver's door is still possible.*

### Enabling

- ▶ Slide override switch ① to the left.

The rear door windows can again be operated using the switches located in the rear doors.

## ▼ Panic alarm

① **PANIC** button**i** USA only:

*This device complies with Part 15 of the FCC Rules. Operation is subject to the following two conditions:*

- (1) *This device may not cause harmful interference, and*
- (2) *this device must accept any interference received, including interference that may cause undesired operation.*

*Any unauthorized modification to this device could void the user's authority to operate the equipment.*

**i** Canada only:

*This device complies with RSS-210 of Industry Canada. Operation is subject to the following two conditions:*

- (1) *This device may not cause interference, and*
- (2) *this device must accept any interference received, including interference that may cause undesired operation of the device.*

*Any unauthorized modification to this device could void the user's authority to operate the equipment.*

**Activating**

- ▶ Press and hold **PANIC** button for at least 1 second.

An audible alarm and blinking turn signal lamps will operate briefly.

**Deactivating**

- ▶ Press **PANIC** button once more.

or

- ▶ Insert the SmartKey in the starter switch.



### Driving safety systems

In this section you will find information on the following driving safety systems:

- ABS (Antilock Brake System)
- BAS (Brake Assist System)
- 4-ETS (Electronic Traction System)
- EBB (Electronic Brake Booster)
- ESP® (Electronic Stability Program)

#### Warning!



The following factors increase the risk of accidents:

- Excessive speed, especially in turns
- Wet and slippery road surfaces
- Following another vehicle too closely

The driving safety systems described in this section cannot reduce these risks or prevent the natural laws of physics from acting on the vehicle.

Always adapt your driving style to the prevailing road and weather conditions and keep a safe distance to other road users and objects on the street.

**i** *In winter operation, the maximum effectiveness of the ABS, the BAS, the ESP®, the EBB, and the 4-ETS is only achieved with winter tires or snow chains as required.*

### ABS

#### Warning!



Do not pump the brake pedal. Use firm, steady brake pedal pressure instead. Pumping the brake pedal defeats the purpose of ABS and significantly reduces braking effectiveness.

The Antilock Brake System (ABS) regulates the brake pressure so that the wheels do not lock during braking. This allows you to maintain the ability to steer your vehicle.

The ABS is functional above a speed of approximately 5 mph (8 km/h) independent of road surface conditions (as long as the differential locks are not engaged).

Continuous steady brake pedal pressure yields the advantages provided by the ABS, namely braking power and the ability to steer the vehicle.

On slippery road surfaces, the ABS will respond even to light brake pressure. The pulsating brake pedal can be an indication of hazardous road conditions and functions as a reminder to take extra care while driving.

The  indicator lamp in the instrument cluster (▷ page 26) comes on when you turn the SmartKey to position **2**. It goes out when the engine is running.

### Braking

At the instant one of the wheels is about to lock up, a slight pulsation can be felt in the brake pedal, indicating that the ABS is in the regulating mode.

- ▶ Keep firm and steady pressure on the brake pedal while experiencing the pulsation.

### Emergency brake maneuver

- ▶ Keep continuous full pressure on the brake pedal.

#### Warning!



When the ABS is malfunctioning, the BAS, the EBB, the ESP®, and the 4-ETS are also switched off. The basic driving and braking functions are still available.

When the ABS is malfunctioning, the wheels may lock during hard braking, reducing steering capability and extending the braking distance.

### Driving safety systems

#### LOW RANGE- ABS

During off-road driving a special low range system for the Antilock Brake System (ABS) is operational with transfer case in position LOW (▷ page 170).

An improved braking action (dig-in effect) is obtained for vehicle speeds up to 37 mph (60 km/h) through a change in the ABS control function.

For more information, see “Practical hints” (▷ page 324).

#### Warning!



The ABS cannot prevent the natural laws of physics from acting on the vehicle, nor can it increase braking or steering efficiency beyond that afforded by the condition of the vehicle brakes and tires or the traction afforded. The ABS cannot prevent accidents, including those resulting from excessive speed in turns, following another vehicle too closely, or hydroplaning. Only a safe, attentive, and skillful driver can prevent accidents. The capabilities of an ABS equipped vehicle must never be exploited in a reckless or dangerous manner which could jeopardize the user's safety or the safety of others.

#### BAS

The Brake Assist System (BAS) operates in emergency situations. If you apply the brakes very quickly, the BAS automatically provides full brake boost, thereby potentially reducing braking distance. Apply continuous full braking pressure until the emergency braking situation is over. The ABS will prevent the wheels from locking.

When you release the brake pedal the brakes function again as normal. The BAS is then deactivated.

With the BAS malfunctioning, the ABS, ESP®, and 4-ETS are also switched off.

#### Warning!



If the BAS is malfunctioning, the brake system is still functioning normally, but without the additional brake boost available that BAS would normally provide in an emergency braking maneuver. Therefore, the braking distance may increase.

**Warning!**

The BAS cannot prevent the natural laws of physics from acting on the vehicle, nor can it increase braking efficiency beyond that afforded by the condition of the vehicle brakes and tires or the traction afforded. The BAS cannot prevent accidents, including those resulting from excessive speed in turns, following another vehicle too closely, or hydroplaning. Only a safe, attentive, and skillful driver can prevent accidents. The capabilities of a BAS equipped vehicle must never be exploited in a reckless or dangerous manner which could jeopardize the user's safety or the safety of others.

For more information, see “Practical hints” (▷ page 340).

**4-ETS**

The 4-Electronic Traction System (4-ETS) improves vehicle's ability to utilize available traction, especially under slippery road conditions. The brakes are applied to the spinning wheel and power is allowed to flow to the wheel(s) with traction.

The 4-ETS function is available between vehicle speeds of 0 mph (km/h) and 37 mph (60 km/h).

The ESP® warning lamp  in the instrument cluster (▷ page 26) comes on when you switch on ignition (▷ page 39). It goes out when the engine is running.

The ESP® warning lamp  starts to flash at any vehicle speed, as soon as a tire loses traction and the wheel begins to spin.

**Warning!**

When you see the ESP® warning lamp  flashing in the instrument cluster, then proceed as follows:

- While driving off, apply as little throttle as possible.
- While driving ease up on the accelerator.
- Adapt your speed and driving style to the prevailing road conditions.

Failure to observe these guidelines could cause the vehicle to skid.

The 4-ETS cannot prevent accidents resulting from excessive speed.

### Driving safety systems

**!** *Operational or performance test must only be conducted on a two-axle dynamometer. If such tests are necessary, contact an authorized Mercedes-Benz Light Truck Center. You could otherwise seriously damage the brake system or the transfer case which is not covered by the Mercedes-Benz Limited Warranty.*

**!** *Because the ESP® operates automatically, the engine and ignition must be shut off (SmartKey in starter switch position **0** or **1**) when testing the parking brake on a brake test dynamometer and such testing should be no longer than 10 seconds.*

*Active braking action through ESP® may otherwise seriously damage the brake system which is not covered by the Mercedes-Benz Limited Warranty.*

For more information, see “Practical hints” (▷ page 330).

#### EBB

The Electronic Brake Booster (EBB) enhances braking effectiveness by allowing the rear brakes to supply a greater proportion of the braking effort in straight line braking circumstances without a loss of vehicle stability.

#### Warning!



If the EBB is malfunctioning, the brake system is still functioning. However, the rear wheels may lock during hard braking, causing you to lose control over the vehicle and possibly causing an accident. Adjust your driving style to the non-operating status of the EBB.

For more information, see the “Practical hints” section (▷ page 327).

#### ESP®

The Electronic Stability Program (ESP®) is operational as soon as the engine is running and monitors the vehicle's traction (force of adhesive friction between the tires and the road surface) and handling.

The ESP® recognizes when a wheel is spinning or if the vehicle starts to skid. By applying the brakes to the appropriate wheel and by limiting engine output, the ESP® works to stabilize the vehicle. The ESP® is especially useful while driving off and on wet or slippery road surfaces. The ESP® also stabilizes the vehicle during braking and steering maneuvers.

The ESP® warning lamp  in the instrument cluster (▷ page 26) flashes when the ESP® is engaged.

The ESP® warning lamp  comes on when you switch on ignition (▷ page 39). It goes out when the engine is running.

**Warning!**

Never switch off the ESP® when you see the ESP® warning lamp  flashing in the instrument cluster. In this case proceed as follows:

- While driving off, apply as little throttle as possible.
- While driving ease up on the accelerator.
- Adapt your speed and driving style to the prevailing road conditions.

Failure to observe these guidelines could cause the vehicle to skid.

The ESP® cannot prevent accidents resulting from excessive speed.

**Warning!**

The ESP® cannot prevent the natural laws of physics from acting on the vehicle, nor can it increase the traction afforded. The ESP® cannot prevent accidents, including those resulting from excessive speed in turns, following another vehicle too closely, or hydroplaning. Only a safe, attentive, and skillful driver can prevent accidents. The capabilities of a ESP® equipped vehicle must never be exploited in a reckless or dangerous manner which could jeopardize the user's safety or the safety of others.

**!** *Operational or performance test must only be conducted on a two-axle dynamometer. If such tests are necessary, contact an authorized Mercedes-Benz Light Truck Center. You could otherwise seriously damage the brake system or the transfer case which is not covered by the Mercedes-Benz Limited Warranty.*

**!** *Because the ESP® operates automatically, the engine and ignition must be shut off when testing the parking brake on a brake test dynamometer and such testing should be no longer than 10 seconds.*

*Active braking action through ESP® may otherwise seriously damage the brake system which is not covered by the Mercedes-Benz Limited Warranty.*

**i** *The ESP® will only function properly if you use wheels of the recommended tire size (▷ page 416).*

**i** *The ABS, BAS, and ESP® are automatically switched off when the differential locks are switched on (▷ page 175).*

## Driving safety systems

### Switching off the ESP®

#### Warning!



The ESP® should not be switched off during normal driving other than in the circumstances described below. Disabling of the system will reduce vehicle stability in standard driving maneuvers.

To improve the vehicle's traction, switch off the ESP® in driving situations where it would be advantageous to have the drive wheels spin and thus cut into surfaces for better grip such as:

- when driving with snow chains
- in deep snow
- sand or gravel
- when driving off-road

#### Warning!



Switch on the ESP® immediately if the aforementioned circumstances do not apply anymore. Otherwise the ESP® will not stabilize the vehicle when it is starting to skid or a wheel is spinning.

When you switch off the ESP®

- the ESP® does not stabilize the vehicle
- the engine output is not limited, which allows the drive wheels to spin and thus cut into surfaces for better grip
- the 4-ETS will still apply the brake to a spinning wheel
- the ESP® continues to operate when you are braking
- you cannot activate the cruise control system
- the cruise control system switches off if currently activated

**i** When the ESP® is switched off and one or more drive wheels are spinning, the ESP® warning lamp  in the instrument cluster flashes. However, the ESP® will then not stabilize the vehicle.

The ESP® switch is located on the upper part of the center console.



① ESP® switch

- ▶ With the engine running, press switch ①.

The ESP® warning lamp  in the instrument cluster comes on.

The ESP® is deactivated.

**Warning!**

When the ESP® warning lamp  is illuminated continuously, the ESP® is switched off or it is not operational due to a malfunction.

Adapt your speed and driving to the prevailing road conditions and to the non-operating status of the ESP®.

**!** *Avoid spinning of a drive wheel for an extended period of time with the ESP® switched off. This may cause serious damage to the drivetrain which is not covered by the Mercedes-Benz Limited Warranty.*

Even if the ESP® has been switched off, it is still active in the following situations:

- when braking
- at vehicle speeds up to approximately 37 mph (60 km/h), if one wheel reaches the grip limit, e.g. when the street is icy on one side

The brake is applied until the wheel regains sufficient traction.

If one or more drive wheels are spinning, the ESP® warning lamp  in the instrument cluster flashes, regardless of the speed.

**i** *If the ESP® is switched off, it will be automatically activated when exceeding a vehicle speed of 37 mph (60 km/h) or exceeding a severity threshold of side acceleration.*

**Switching on the ESP®**

- ▶ Press switch  once more.

The ESP® warning lamp  in the instrument cluster goes out.

You are now again in normal driving mode with the ESP® switched on.

For more information, see “Practical hints” (▷ page 330).



## Anti-theft systems

### Immobilizer

---

The immobilizer prevents unauthorized persons from starting your vehicle.

#### Activating

- ▶ Remove the SmartKey from the starter switch.

#### Deactivating

- ▶ Turn the SmartKey in the starter switch to position **2** (▷ page 39).

**i** Starting the engine will also deactivate the immobilizer.

*In case the engine cannot be started (yet the vehicle's battery is charged), the system is not operational. Contact an authorized Mercedes-Benz Light Truck Center or call 1-800-FOR-MERCEdes (in the USA), or 1-800-387-0100 (in Canada).*

### Anti-theft alarm

---

Once the alarm system has been armed, a visual and audible alarm is triggered when someone opens

- a door
- the tailgate
- the hood

The alarm will stay on, even if the activating element (a door, for example) is immediately closed.

The alarm system will also be triggered when

- someone attempts to raise the vehicle
- the vehicle is opened with the mechanical key
- someone opens a door from the inside
- someone opens the tailgate from the inside

### Arming the alarm system

The alarm system is armed after you have locked the vehicle with the SmartKey.

The alarm system indicator lamp is located in the tow-away alarm switch on the upper part of the center console.



① Alarm system indicator lamp

- ▶ Make sure all doors and the tailgate are closed.
- ▶ Lock the vehicle with the SmartKey (▷ page 65).

The turn signal lamps flash three times to indicate that the vehicle is locked.

The alarm system is armed within approximately 15 seconds. Alarm system indicator lamp ① flashes.

**i** If the turn signal lamps do not blink three times, one of the following elements may not be properly closed:

- a door
- the tailgate

*Close the respective element and lock the vehicle again.*

### Disarming the alarm system

- ▶ Unlock the vehicle with the SmartKey (▷ page 38).

The turn signal lamps flash once to indicate that the alarm system is disarmed. Alarm system indicator lamp ① goes out.

**i** The alarm system will rearm automatically after approximately 40 seconds if neither a door nor the tailgate is opened.

### Canceling the alarm

- ▶ Insert the SmartKey in the starter switch.

or

- ▶ Press button  or  on the SmartKey.

## Anti-theft systems

### Tow-away alarm

Once the tow-away alarm is armed, a visual and audible alarm will be triggered when someone attempts to raise the vehicle.

### Arming tow-away alarm

- ▶ Lock the vehicle with the SmartKey (▷ page 65).

The tow-away alarm is automatically armed after approximately 30 seconds.

### Disarming tow-away alarm

To prevent triggering the tow-away alarm feature, switch off the tow-away alarm before towing the vehicle, or when parking on a surface subject to movement, such as a ferry or auto train.

The tow-away alarm off switch is located on the upper part of the center console.



- ① Tow-away alarm off switch
- ② Indicator lamp

- ▶ Switch off the ignition and remove the SmartKey from the starter switch.



**i** You cannot disarm the tow-away alarm when the ignition is switched on.

- ▶ Press switch ①.  
Indicator lamp ② comes on briefly.
- ▶ Exit and lock the vehicle with the SmartKey (▷ page 65).

**i** When you unlock the vehicle, the tow-away protection disarms automatically.

The tow-away alarm remains disarmed until you lock your vehicle again.

### Canceling the tow-away alarm

- ▶ Press the  or  button on the SmartKey.

or

- ▶ Insert the SmartKey in the starter switch.

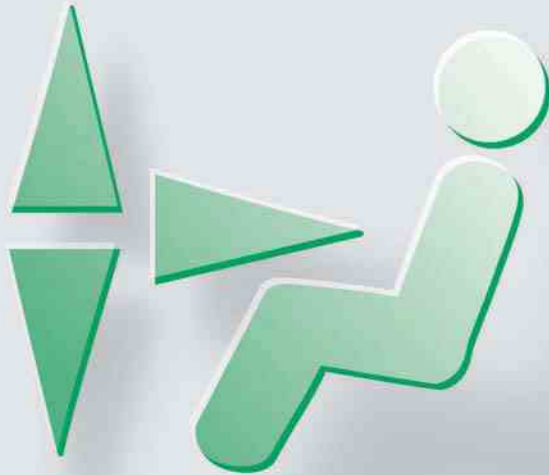

**Locking and unlocking**

**Seats**

**Memory function**

**Lighting**

**Instrument cluster**

**Control system**

**Automatic transmission**

**Transfer case**

**Differential locks**

**Good visibility**

**Climate control**

**Power windows**

**Power tilt/sliding sunroof**

**Driving systems**

**Loading**

**Useful features**

### Locking and unlocking

In the “Controls in detail” section you will find detailed information on how to operate the equipment installed in your vehicle. If you are already familiar with the basic functions of your vehicle, this section will be of particular interest to you.

To quickly familiarize yourself with the basic functions of the vehicle, refer to the “Getting started” section of this manual. The corresponding page numbers are given at the beginning of each segment.

For more information on locking and unlocking, see the “Getting started” section (▷ page 38) and (▷ page 65).

#### SmartKey

Your vehicle comes supplied with two SmartKeys, each with remote control and a removable mechanical key.

The locking tabs for the mechanical key portion of the two SmartKeys are a different color to help distinguish each SmartKey unit.



The SmartKey provides an extended operating range. To prevent theft, however, it is advisable to only unlock the vehicle when you are in close proximity to it.

The SmartKey centrally locks and unlocks:

- the doors
- the tailgate
- the fuel filler flap



#### SmartKey with remote control

- ①  Lock button
- ② Locking tab for mechanical key
- ③ Mechanical key (▷ page 370)
- ④  Unlock button
- ⑤ Battery check lamp
- ⑥  PANIC Panic button (▷ page 87)

**Warning!**

When leaving the vehicle, always remove the SmartKey from the starter switch, take it with you, and lock the vehicle. Do not leave children unattended in the vehicle, or with access to an unlocked vehicle. It is possible for children to open a locked door from the inside, which could result in an accident and/or serious personal injury.

**!** To prevent possible malfunction, avoid exposing the SmartKey to high levels of electromagnetic radiation.

**!** If you cannot lock or unlock the vehicle with the SmartKey, the batteries in the SmartKey are discharged, the SmartKey is malfunctioning, or the vehicle battery is drained.

- Check the batteries in the SmartKey (▷ page 103) and replace them if necessary (▷ page 376).
- Unlock the vehicle as described in the “Practical hints” section (▷ page 370).
- Lock the vehicle as described in the “Practical hints” section (▷ page 371).
- Have the vehicle battery and the vehicle battery connections checked at an authorized Mercedes-Benz Light Truck Center (▷ page 396).

If the SmartKey is malfunctioning, contact an authorized Mercedes-Benz Light Truck Center.



**i** USA only:

This device complies with Part 15 of the FCC Rules. Operation is subject to the following two conditions:

- (1) This device may not cause harmful interference, and
- (2) this device must accept any interference received, including interference that may cause undesired operation.

Any unauthorized modification to this device could void the user’s authority to operate the equipment.



**i** Canada only:

This device complies with RSS-210 of Industry Canada. Operation is subject to the following two conditions:

- (1) This device may not cause interference, and
- (2) this device must accept any interference received, including interference that may cause undesired operation of the device.

Any unauthorized modification to this device could void the user’s authority to operate the equipment.

### Locking and unlocking

**i** You can also open or close the power windows and tilt/sliding sunroof using the SmartKey, see “Summer opening feature” (▷ page 193) and see “Convenience closing feature” (▷ page 194).

#### Factory setting

#### Global unlocking

- ▶ Press button .
- All turn signal lamps flash once.
- The locking knobs in the doors move up.
- The anti-theft alarm system is disarmed.

The vehicle will lock again automatically and rearm the anti-theft alarm system within approximately 40 seconds of unlocking if

- neither door nor tailgate is opened
- the SmartKey is not inserted in the starter switch
- the central locking switch is not activated

#### Global locking



- ▶ Press button .

With the hood, tailgate and all doors closed:

- All turn signal lamps flash three times.
- The locking knobs in the doors move down.
- The anti-theft alarm system is armed.

#### Selective setting

If you frequently travel alone, you may wish to reprogram the SmartKey so that pressing button  only unlocks the driver's door and the fuel filler flap.

- ▶ Press and hold buttons  and  simultaneously for about 5 seconds until battery check lamp  (▷ page 100) flashes twice.

The SmartKey will then function as follows:

#### Unlocking driver's door and fuel filler flap

- ▶ Press button  once.
  - All turn signal lamps flash once.
  - The locking knobs in the doors move up.
  - The anti-theft alarm system is disarmed.

**Global unlocking**

- ▶ Press button  twice.
  - All turn signal lamps flash once.
  - The locking knobs in the doors move up.
  - The anti-theft alarm system is disarmed.



**Global locking**

- ▶ Press button .

With the hood, tailgate and all doors closed:

- All turn signal lamps flash three times.
- The locking knobs in the doors move down.
- The anti-theft alarm system is armed.



**Restoring to factory setting**

- ▶ Press and hold buttons  and  simultaneously for about 6 seconds until battery check lamp  (▷ page 100) flashes twice.

**Checking batteries in the SmartKey**



- ▶ Press button  or .

Battery check lamp  (▷ page 100) comes on briefly to indicate that the SmartKey batteries are in order.

 *If battery check lamp  does not come on briefly during check, the SmartKey batteries are discharged.*

*Replace the batteries (▷ page 376).*

*You can obtain the required batteries at any authorized Mercedes-Benz Light Truck Center.*

 *If the batteries are checked within signal range of the vehicle, pressing button  or  will lock or unlock the vehicle accordingly.*

**Loss of the SmartKey**

If you lose your SmartKey or mechanical key, you should do the following:

- ▶ Have the SmartKey deactivated at an authorized Mercedes-Benz Light Truck Center.
- ▶ Report the loss of the SmartKey or the mechanical key immediately to your car insurance company.
- ▶ If necessary, have the mechanical lock replaced.

Any authorized Mercedes-Benz Light Truck Center will be glad to supply you with a replacement.



### Locking and unlocking

#### Opening the doors from the inside

You can open a locked door from the inside. Open door only when conditions are safe to do so.

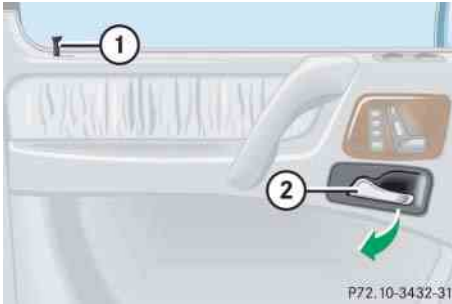



① Locking knob

② Inside door handle

**i** If the vehicle has previously been locked with the SmartKey, opening a door or the tailgate from the inside will trigger the anti-theft alarm system.

To cancel the alarm, do one the following:

- Insert the SmartKey in the starter switch.
- Press button  or  on the SmartKey.

#### Front doors

- ▶ Pull on inside door handle ② on the respective front door to open door.

If the door was locked, locking knob ① will move up.

**i** If you hear a warning signal you have forgotten to switch off the headlamps before opening the driver's door.

In addition the message *Switch off lights* appears in the multifunction display.

Switch off the headlamps.

**!** Failure to switch off the headlamps when leaving the vehicle may result in a discharged battery.

#### Rear doors

- ▶ Pull up locking knob ① on the respective rear door to unlock door.
- ▶ Pull on inside door handle ② on the respective rear door to open door.

### Tailgate

#### Warning!



The tailgate swings open to one side. Always make sure there is sufficient clearance for the tailgate.

Make sure the tailgate is closed when the engine is running and while driving. Among other dangers, deadly carbon monoxide (CO) gases may enter vehicle interior resulting in unconsciousness and death.

### Opening the tailgate from the outside

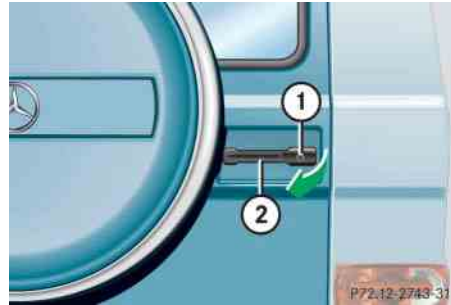

- ① Lock cylinder
- ② Tailgate handle

- i *The vehicle must be unlocked (▷ page 38).*
- ▶ Press lock cylinder ① and pull on tailgate handle ②.
- ▶ Open the tailgate to the side.

### Opening the tailgate from inside

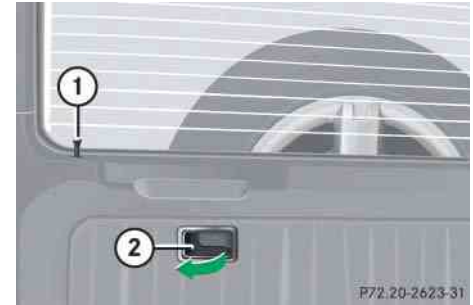

- ① Locking knob
- ② Inside door handle

- ▶ Pull on inside door handle ② to open the tailgate.
- If the door was locked:
- ▶ Pull up locking knob ① to unlock the tailgate.
  - ▶ Pull on door handle ② to open the tailgate.

### Locking and unlocking

#### Closing the tailgate

##### Warning!



To prevent possible personal injury, always keep hands and fingers away from the cargo compartment opening when closing the tailgate. Be especially careful when small children are around.

When leaving the vehicle, always remove the SmartKey from the starter switch, take it with you, and lock the vehicle. Do not leave children unattended in the vehicle, or with access to an unlocked vehicle. Unsupervised use of vehicle equipment may cause an accident and/or serious personal injury.

##### Warning!



Never drive vehicle with the tailgate open. Deadly carbon monoxide (CO) gases may enter vehicle interior resulting in unconsciousness and death.

**i** To prevent an inadvertent lockout, do not place the SmartKey in the cargo compartment.

#### Automatic central locking

The doors and the tailgate lock automatically when the ignition is switched on and the wheels are turning at vehicle speeds of approximately 9 mph (15 km/h) or more.

You can open a locked door from the inside. Open door only when conditions are safe to do so.

**i** The doors and the tailgate unlock automatically after an accident if the force of the impact exceeds a preset threshold.

*The vehicle automatically locks when the ignition is switched on and the wheels are turning at vehicle speeds of approximately 9 mph (15 km/h) or more. You could therefore lock yourself out when the vehicle*

- *is pushed or towed*
- *is on a test stand*

For information on towing the vehicle, see “Towing the vehicle” (▷ page 401).

You can deactivate the automatic locking mode using the control system (▷ page 155).

### Locking and unlocking from the inside

You can lock or unlock the doors and the tailgate from inside using the central locking or unlocking switch. This can be useful, for example, if you want to lock the vehicle before starting to drive.

The fuel filler flap cannot be locked or unlocked with the central locking or unlocking switch.

#### Warning!



When leaving the vehicle, always remove the SmartKey from the starter switch, take it with you, and lock the vehicle. Do not leave children unattended in the vehicle, or with access to an unlocked vehicle. Unsupervised use of vehicle equipment may cause an accident and/or serious personal injury.

The switches are located on the upper part of the center console.



- ① Central unlocking switch
- ② Central locking switch

### Locking

- ▶ Press central locking switch ②.

If all doors and the tailgate are closed, the vehicle locks.

### Unlocking

- ▶ Press central unlocking switch ①.

The vehicle unlocks.

**i** You can open a locked door from inside at any time. Open door only when conditions are safe to do so.

*If the vehicle was previously centrally locked with the SmartKey, it will not unlock using central unlocking switch ①.*

*If the vehicle was previously locked with central locking switch ②:*

- *and the SmartKey is set to factory settings, the complete vehicle is unlocked when a front door is opened from the inside.*
- *and the SmartKey is set to selective settings, only the front door opened from the inside is unlocked.*

### Seats

For information on seat adjustment, see the “Getting started” section (▷ page 41).

For more information on seats, see “Loading” (▷ page 206).

#### Removing and installing front seat head restraints

For information on head restraint adjustment, see the “Getting started” section (▷ page 43).

#### Warning!



Do not drive the vehicle without the seat head restraints. Head restraints are intended to help reduce injuries during an accident.

For your protection, drive only with properly positioned head restraints.

Adjust the head restraint in such a way that it is as close to the head as possible and the center of the head restraint supports the back of the head at eye level. This will reduce the potential for injury to the head and neck in the event of an accident or similar situation.

Do not interchange head restraints from front and rear seat.

**i** Tilt the seat backrest rearward for easier removal and installation of the head restraints (▷ page 43).

The switch for the front seat head restraint is located on the respective front door.



① Switch

#### Removing front seat head restraint

- ▶ Press switch ① upwards and hold until the head restraint is fully extended.
- ▶ Pull out the head restraint with both hands.

### Installing front seat head restraint

- ▶ Press switch ① upwards and hold for about 5 seconds.
- ▶ Insert the head restraint into openings on the seat backrest.

**i** The guide bar with the detent must be on the left.

- ▶ Push the head restraint down until it engages.
- ▶ Adjust the head restraint to the desired position.

### Multicontour seat\*

The multicontour seat has an extendable seat cushion and inflatable air chambers built into the seat backrest to provide additional lumbar and side support.

The seat cushion depth, seat backrest cushion-height and curvature can be continuously varied with switches on the inside of each front seat.

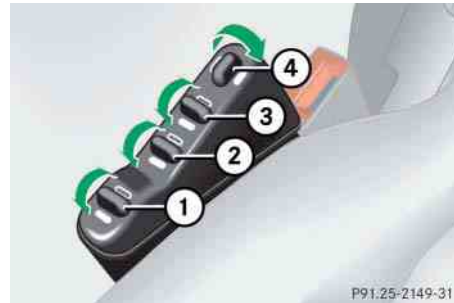

- ① Seat cushion depth
- ② Backrest bottom
- ③ Backrest center
- ④ Backrest side bolsters

- ▶ Switch on the ignition (▷ page 39).

### Seat cushion depth

- ▶ Adjust the seat cushion depth to the length of your upper leg using switch ①.

### Backrest contour

- ▶ Adjust the contour of the backrest to the desired position using switches ② and ③.

### Backrest side bolsters

- ▶ Adjust the backrest side bolsters so that they provide good lateral support using switch ④.

### Rear seats

#### Warning!



According to accident statistics, children are safer when properly restrained in the rear seating positions than in the front seating position. Thus, we strongly recommend that children be placed in the rear seats whenever possible. Regardless of seating position, children 12 years old and under must be seated and properly secured in an appropriately sized infant restraint, toddler restraint, or booster seat recommended for the size and weight of the child. For additional information, see “Children in the vehicle” (▷ page 78).

A child’s risk of serious or fatal injuries is significantly increased if the child restraints are not properly secured in the vehicle and/or the child is not properly secured in the child restraint.

#### Warning!



Always lock seat backrest in its upright position when rear seat bench is occupied by passengers, or cargo is being carried behind the rear seat bench.

To help avoid personal injury from smaller objects flying in the occupant area during a collision or sudden maneuver, always use partition net when transporting cargo (▷ page 210).

### Head restraint height

#### Warning!



Do not drive the vehicle without the seat head restraints installed when the rear seat bench is occupied. Head restraints are intended to help reduce injuries during an accident.

For your protection, drive only with properly positioned head restraints.

Adjust the head restraint in such a way that it is as close to the head as possible and the center of the head restraint supports the back of the head at eye level. This will reduce the potential for injury to the head and neck in the event of an accident or similar situation.

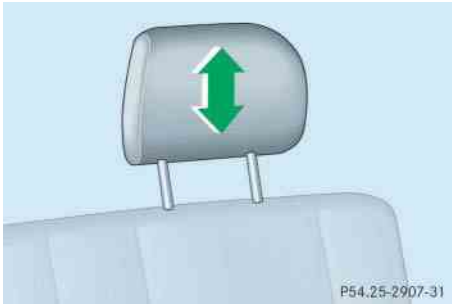

Raising:

- ▶ Manually adjust the height of the head restraint by pulling it upward to the desired position.

Lowering:

- ▶ Manually adjust the height of the head restraint by pushing it downward to the desired position.

## Removing and installing rear seat head restraints

### Warning!



Do not drive the vehicle without the seat head restraints installed when the rear seat bench is occupied. Head restraints are intended to help reduce injuries during an accident.

For your protection, drive only with properly positioned head restraints.

Adjust the head restraint in such a way that it is as close to the head as possible and the center of the head restraint supports the back of the head at eye level. This will reduce the potential for injury to the head and neck in the event of an accident or similar situation.

Do not interchange head restraints from front and rear seat.

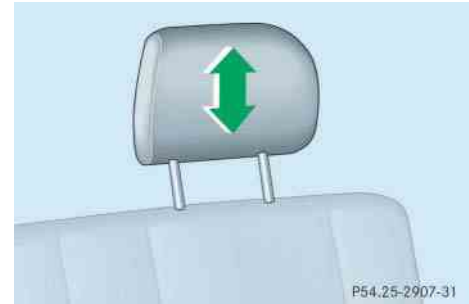

### Removing rear seat head restraints

- ▶ Pull out the head restraint with both hands.

**i** *The head restraint(s) should be stored in a secure place.*

### Installing rear seat head restraints

- ▶ Insert the head restraint into openings on the seat backrest.
- ▶ Push the head restraint down to the stop.
- ▶ Adjust the head restraint to the desired position.



## Seats

### Seat heating

The switches for front seat heating are located on the upper part of the center console.

The switches for rear seat heating (rear outer seats) are located on the B-pillars (> page 113).

### Front seat heating



- ① Seat heating switch
- ② Indicator lamps

The red indicator lamps in the switch come on to show which heating level you have selected.

| Level |   |
|-------|---|
| 3     | Three indicator lamps on (highest level)<br>The seat heating automatically switches to level 2 after approximately 5 minutes. |
| 2     | Two indicator lamps on<br>The seat heating automatically switches to level 1 after approximately 10 minutes.                  |
| 1     | One indicator lamp on (lowest level)<br>The seat heating automatically switches off after approximately 20 minutes.           |
| off   | No indicator lamp on  |

- ▶ Switch on the ignition (> page 39).

### Switching on seat heating

- ▶ Press switch ① once.  
Three red indicator lamps ② in the switch come on.
- ▶ Continue pressing switch ① until desired seat heating level is reached.

### Switching off seat heating

- ▶ Press switch ① repeatedly until all indicator lamps ② in the switch go out.

**i** If one or more of indicator lamps ② in seat heating switch ① are flashing, there is insufficient voltage available due to too many electrical consumers are switched on. The seat heating switches off automatically.

The seat heating will switch back on again automatically as soon as sufficient voltage is available.

Rear seat heating



- ① Normal heating
- ② Rapid heating

| Level |   |
|-------|---|
| 2     | Two indicator lamps on (Rapid heating)<br><br>The seat heating automatically switches to normal heating mode after approximately 5 minutes. |

| Level |   |
|-------|---|
| 1     | One indicator lamp on (Normal heating)<br><br>The seat heating automatically switches off after approximately 30 minutes. |
| off   | No indicator lamp on  |

- ▶ Switch on the ignition (▷ page 39).

**Switching on seat heating**

- ▶ Press upper switch position ①.  
  
One red indicator lamp in the switch comes on.

**Switching off seat heating**

- ▶ Press upper switch position ① once more.  
  
The red indicator lamp in the switch goes out.

**Switching on rapid seat heating**

- ▶ Press lower switch position ②.  
  
Both red indicator lamps in the switch come on.

**Switching off rapid seat heating**

- ▶ Press lower switch position ② once more.  
  
Both red indicator lamps in the switch go out.

**i** If one or both of the indicator lamps in the seat heating switch are flashing, there is insufficient voltage available due to too many electrical consumers are switched on. The seat heating switches off automatically.

The seat heating will switch back on again automatically as soon as sufficient voltage is available.

### Memory function

Prior to operating the vehicle, the driver should check and adjust the seat height, seat position fore and aft, and seat backrest angle if necessary, to ensure adequate control, reach and comfort. The head restraint should also be adjusted for proper height. See also the section on air bags (▷ page 70) for proper seat positioning.

In addition, adjust the steering wheel to ensure adequate control, reach, operation and comfort. Both the interior and exterior rear view mirrors should be adjusted for adequate rear vision.

Fasten seat belts. Infants and small children should be seated in a properly secured restraint system that complies with U.S. Federal Motor Vehicle Safety Standards 213 and 225 and Canadian Motor Vehicle Safety Standards 213 and 210.2.

With the memory function you can store up to three different configurations.

Each stored position on the driver's side includes the following settings:

- Seat position
- Multicontour seat\*: previously saved setting
- Steering wheel position
- Exterior rear view mirrors' position

Each stored position on the passenger side includes the following settings:

- Seat position
- Multicontour seat\*: previously saved setting

#### Warning!



Do not activate the memory function while driving. Activating the memory function while driving could cause the driver to lose control of the vehicle.

The memory button and memory position button are located on each front door.



① Memory button

1, 2, 3 Memory position button

▶ Switch on the ignition (▷ page 39).

or

▶ Open the respective door.

### Storing positions into memory

- ▶ Adjust the seats (▷ page 42).
- ▶ On the driver's side, additionally adjust the steering wheel (▷ page 44) and exterior rear view mirrors (▷ page 46) to the desired positions.
- ▶ Press memory button ①.
- ▶ Release memory button ① and press memory position button 1, 2, or 3 within 3 seconds.

All settings are stored to the selected position.

### Recalling positions from memory

**!** Do not operate the power seats using memory button ① if the seat backrest is in an excessively reclined position. Doing so could cause damage to front or rear seats.

*Move seat backrest to an upright position first.*

- ▶ Press and hold memory position button 1, 2, or 3 until the seat, steering wheel and exterior rear view mirrors have fully moved to the stored positions.

**i** Releasing the memory position button stops movement to the stored positions immediately.

### Memory function

#### Storing exterior rear view mirror parking position

For easier parking, you can adjust the passenger-side exterior rear view mirror so that you can see the rear wheel and the road curb as soon as you engage reverse gear **R**.

For information on activating the parking position, see “Activating exterior rear view mirror parking position” (▷ page 178).

The memory button is located on the driver's door. The adjustment button and exterior rear view mirror buttons are located on the dashboard to the left of the steering wheel.

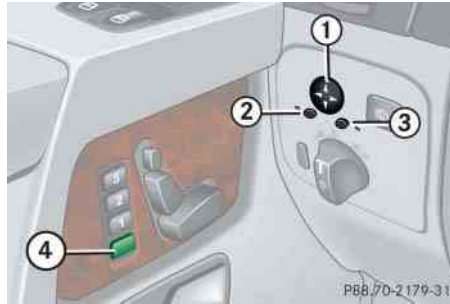

- ① Adjustment button
- ② Driver's side exterior rear view mirror button
- ③ Passenger-side exterior rear view mirror button
- ④ Memory button

▶ Switch on the ignition (▷ page 39).

▶ Press button ③.

The passenger-side exterior rear view mirror is selected.

▶ Adjust the exterior rear view mirror with adjustment button ① so that you see the rear wheel and the road curb.

▶ Press memory button ④.

▶ Within 3 seconds, press bottom of adjustment button ①.

The parking position is stored if the mirror does not move.

**i** If the mirror does move, repeat the above steps. After the setting is stored, you can move the mirror again.

▼ Lighting

For information on how to switch on the headlamps and use the turn signals, see “Switching on headlamps” (▷ page 56) and see “Turn signals” (▷ page 57).

**i** If you drive in countries where vehicles drive on the other side of the road than the country in which the vehicle is registered, you must have the headlamps modified for symmetrical low beams. Relevant information can be obtained at any authorized Mercedes-Benz Light Truck Center.

**Exterior lamp switch**

The exterior lamp switch is located on the dashboard to the left of the steering wheel.



|   |  |   |
|---|--|---|
| 1 |  | Standing lamps, left (turn left two stops)                        |
| 2 |  | Standing lamps, right (turn left one stop)                        |
| 3 |  | Off<br>Daytime running lamp mode (▷ page 119)                     |
| 4 |  | Automatic headlamp mode<br>Daytime running lamp mode (▷ page 119) |

|   |  |   |
|---|--|---|
| 5 |  | Parking lamps (also tail lamps, license plate lamps, side marker lamps, instrument panel lamps) |
| 6 |  | Low beam headlamps or high beam headlamps   |
| 7 |  | Front fog lamps   |
| 8 |  | Rear fog lamp   |

**i** If you hear a warning signal you have forgotten to switch off the low beam headlamps or the parking lamps before opening the driver's door.

In addition the message Switch off lights appears in the multifunction display.

Switch off the low beam headlamps or the parking lamps.

If the message Turn off lights or remove key appears in the multifunction display remove the SmartKey from the starter switch or switch off the automatic headlamp mode.

**!** Failure to switch off the exterior lamps when leaving the vehicle may result in a discharged battery.

### Lighting

#### Low beam headlamps

The low beam headlamps can be switched on and off with the exterior lamp switch using the manual headlamp mode.

- ▶ Turn the exterior lamp switch to position .

The following lamps switch on:

- Low beam headlamps
- Tail and parking lamps
- License plate lamps
- Side marker lamps

#### Automatic headlamp mode

The following lamps switch on and off automatically depending on the brightness of the ambient light:



- Low beam headlamps
- Tail and parking lamps
- License plate lamps
- Side marker lamps

#### Warning!



If the exterior lamp switch is set to **AUTO**, the headlamps will not be automatically switched on under foggy conditions.

To minimize risk to you and to others, activate headlamps by turning exterior lamp switch to  when driving or when traffic and/or ambient lighting conditions require you to do so.

In low ambient lighting conditions, only switch from position **AUTO** to  with the vehicle at a standstill in a safe location. Switching from **AUTO** to  will briefly switch off the headlamps. Doing so while driving in low ambient lighting conditions may result in an accident.

The automatic headlamp feature is only an aid to the driver. The driver is responsible for the operation of the vehicle's lights at all times.

- ▶ Turn the exterior lamp switch to position **AUTO**.

With the SmartKey in starter switch position **1**, the tail and parking lamps, the license plate lamps and the side marker lamps will switch on and off depending on the brightness of the ambient light.

When the engine is running the low beam headlamps, the tail and parking lamps, the license plate lamps and the side marker lamps will switch on and off depending on the brightness of the ambient light.

**i** *Canada only:*  
High beam headlamps are only available with the exterior lamp switch in position .

### Daytime running lamp mode

In Canada the daytime running lamp mode is mandatory and therefore in a constant mode.

By default, the daytime running lamp mode is deactivated. Activate the daytime running lamp mode using the control system, see “Setting daytime running lamp mode (USA only)” (▷ page 151).

- ▶ Turn the exterior lamp switch to position **0** or **AUTO**.

When the engine is running, the low beam headlamps are switched on.

In low ambient light conditions, the following lamps will switch on additionally:

- Tail and parking lamps
- License plate lamps
- Side marker lamps

**i** *With the daytime running lamp mode activated and the engine running, you cannot switch off the low beam headlamps manually.*

### Canada only:

**i** *With the exterior lamp switch in position **0** or **AUTO**, you cannot switch on the high beam headlamps.*

*The high beam flasher is available at all times.*



*For nighttime driving turn the exterior lamp switch to position  to permit activation of the high beam headlamps.*

When the engine is running, and you shift from a driving position to neutral position **N** or park position **P** with the vehicle at standstill, the low beam headlamps will switch off with a 3-minute delay.





### Lighting

When the engine is running, and you

- turn the exterior lamp switch to position , the low beam headlamps, the tail and parking lamps, the license plate lamps and the side marker lamps switch on.
- turn the exterior lamp switch to position , the manual headlamp mode has priority over the daytime running lamp mode.



The corresponding exterior lamps switch on (▷ page 117).

#### **USA only:**

 *With the exterior lamp switch in position , you cannot switch on the high beam headlamps.*

*The high beam flasher is available at all times.*

*For nighttime driving turn the exterior lamp switch to position  or **AUTO** to permit activation of the high beam headlamps.*

When the engine is running, and you turn the exterior lamp switch to position  or , the manual headlamp mode has priority over the daytime running lamp mode.

The corresponding exterior lamps switch on (▷ page 117).

#### **Locator lighting and night security illumination**

The locator lighting and the night security illumination are described in the “Control system” section, see “Setting locator lighting” (▷ page 152) and “Setting night security illumination” (▷ page 153).

#### **Locator lighting lamps in exterior rear view mirrors**



If the vehicle is centrally unlocked in the darkness, the locator lighting lamps in the exterior rear view mirrors come on.

If a door is opened, the lamp on the corresponding side goes out. If no doors are opened, the lamps will go out:

- after a maximum of 40 seconds
- immediately, when you switch on the ignition

## Fog lamps



**Warning!**

In low ambient lighting or foggy conditions, only switch from position **AUTO** to  with the vehicle at a standstill in a safe location. Switching from **AUTO** to  will briefly switch off the headlamps. Doing so while driving in low ambient lighting conditions may result in an accident.

**i** Fog lamps will operate with the parking lamps and/or the low beam headlamps on. Fog lamps should only be used in conjunction with low beam headlamps. Consult your State or Province Motor Vehicle Regulations regarding permissible lamp operation.

**i** Fog lamps cannot be switched on with the exterior lamp switch in position **AUTO**. To switch on the fog lamps, turn the exterior lamp switch to position  first.

**Front fog lamps**

- ▶ Turn the exterior lamp switch to position  or  (▷ page 117).
- ▶ Pull out the exterior lamp switch to first stop (▷ page 117).

The front fog lamps switch on.

The green indicator lamp  in the exterior lamp switch comes on (▷ page 117).

- ▶ Push in the exterior lamp switch.

The front fog lamps switch off.

The green indicator lamp  in the exterior lamp switch goes out.

**Rear fog lamp (driver's side only)**

- ▶ Turn the exterior lamp switch to position  (▷ page 117).
- ▶ Pull out the exterior lamp switch to second stop (▷ page 117).

The front fog lamps and the rear fog lamp switch on.

The yellow indicator lamp  in the exterior lamp switch comes on (▷ page 117).

- ▶ Push in the exterior lamp switch to first stop.

The rear fog lamp switches off.

The yellow indicator lamp  in the exterior lamp switch goes out.

The front fog lamps remain lit.

### Lighting



#### Combination switch

The combination switch is located on the left of the steering column.



- ① High beam
- ② High beam flasher

#### High beam

- ▶ Canada only: Turn the exterior lamp switch to position  (▷ page 117).
- or
- ▶ USA only: Turn the exterior lamp switch to position  or **AUTO** (▷ page 117).
- ▶ Push the combination switch in direction of arrow ① to switch on the high beam.

The high beam headlamp indicator lamp  in the instrument cluster comes on (▷ page 26).

- ▶ Pull the combination switch in direction of arrow ② to its original position to switch off the high beam.

The high beam headlamp indicator lamp  in the instrument cluster goes out.

#### High beam flasher

- ▶ Pull the combination switch briefly in direction of arrow ②.

#### Corner-illuminating front fog lamps

The corner-illuminating front fog lamps improve illumination of the area in the direction into which you are turning.

The corner-illuminating front fog lamps will operate with the engine running and with

- the exterior lamp switch in position  (▷ page 117)

or

- the exterior lamp switch in position **AUTO** (▷ page 117)

or

- the daytime running lamp mode activated (▷ page 119)

 *The corner-illuminating front fog lamps will only come on in low ambient lighting conditions.*

 *If you are driving faster than 25 mph (40 km/h) or have the front fog lamps switched on, the corner-illuminating function is not available.*

## Driving forward

### Switching on corner-illuminating front fog lamps

- ▶ Depending on whether you are turning left or right, switch on the left or right turn signal (▷ page 57).

The respective front fog lamp comes on and illuminates the area in the direction into which you are turning.

or

- ▶ Turn steering wheel in desired direction.

The front fog lamp on the side of your steering direction comes on.

**i** *If you have switched on the turn signal for one side but turn the steering wheel in the opposite direction, the corner-illuminating front fog lamp comes on for the side indicated by the turn signal.*

*The corner-illuminating front fog lamp remains lit for a maximum of three minutes. Afterwards, it goes out even if the turn signal is still switched on.*

**i** *The corner-illuminating front fog lamps temporarily come on on both sides of the vehicle if you turn the steering wheel in one direction and then again in the other direction shortly thereafter.*

**i** *The corner-illuminating front fog lamps will come on automatically depending on the steering angle, even if you did not switch on either turn signal. If the corner-illuminating front fog lamps came on automatically, they will also go out automatically depending on the steering angle.*

### Switching off corner-illuminating front fog lamps

The combination switch for the turn signal resets automatically after major steering wheel movements. This will switch off the corner-illuminating front fog lamps if they were activated by switching on the left or right turn signal.

If the turn signal should stay on after making the turn, the turn signal and the corner-illuminating front fog lamps can be switched off by returning the combination switch to its original position.

**i** *There may be a brief delay before the corner-illuminating front fog lamps switch off.*

### Lighting

#### Driving in reverse

##### **Switching on corner-illuminating front fog lamps**

- ▶ Place the gear selector lever in reverse gear **R** (▷ page 162).

The front fog lamp opposite to your steering direction comes on.

##### **Switching off corner-illuminating front fog lamps**

- ▶ Place the gear selector lever to a position other than reverse gear **R** (▷ page 162).

The respective corner-illuminating front fog lamp goes out.

#### Hazard warning flasher

The hazard warning flasher can be switched on at all times, even with the SmartKey removed from the starter switch.

The hazard warning flasher switches on automatically when an air bag deploys.

The hazard warning flasher switch is located on the upper part of the center console.



① Hazard warning flasher switch

#### Switching on hazard warning flasher

- ▶ Press hazard warning flasher switch ①.

All turn signals are flashing.

**i** *With the hazard warning flasher activated and the combination switch set for either left or right turn, only the respective turn signals will operate when the ignition is switched on.*

#### Switching off hazard warning flasher

- ▶ Press hazard warning flasher switch ① once more.

All turn signals go out.

**i** *If the hazard warning flasher has been activated automatically, press hazard warning flasher switch ① once to switch it off.*

## Interior lighting in the front

The controls for the interior lighting are located in the overhead control panel.



- ① Left reading lamp
- ② Left reading lamp switch
- ③ Right reading lamp switch
- ④ Right reading lamp
- ⑤ Rocker switch for automatic control
- ⑥ Interior lamp

**!** An interior lamp switched on manually does not go out automatically.

Leaving an interior lamp switch in the ON position for extended periods of time with the engine turned off could result in a discharged battery.

### Automatic control

**i** The interior lighting is factory-set to automatic mode.

### Deactivating automatic control

- ▶ Press symbol  on rocker switch ⑤.

The interior lighting remains switched off in darkness, even when you

- unlock the vehicle
- remove the SmartKey from the starter switch
- open a door

### Activating automatic control

- ▶ Move rocker switch ⑤ to center position.

The interior lighting (except cargo compartment lamps) comes on in darkness when you

- unlock the vehicle
- remove the SmartKey from the starter switch
- open a front door (only the interior lighting in the front comes on)
- open a rear door (only the rear interior lamps come on, if the rear automatic control is activated (▶ page 126)

The interior lighting switches off after 10 seconds if feature is activated, see “Setting interior lighting delayed shut-off” (▶ page 154).

**i** If a door remains open, the interior lamps switch off automatically after approximately 5 minutes when the SmartKey is removed or in starter switch position 0.

### Lighting

#### Manual control

**!** To prevent the vehicle battery from being discharged, all interior lamps switch off automatically after approximately 30 minutes with a door or the tailgate open and the SmartKey removed from the starter switch.

An interior lamp switched on manually does not go out automatically. Before leaving the vehicle, make sure the interior lamps are switched off.

#### Switching interior lighting on

- ▶ Press symbol  on rocker switch ⑤.

Interior lamp ⑥ comes on.

#### Switching interior lighting off

- ▶ Move rocker switch ⑤ to center position.

Interior lamp ⑥ goes out.

Automatic control is activated.

#### Rear interior lamps

The rear interior lamps are located above the rear seat bench on the left and right side.



#### Right overhead control panel shown, left overhead control panel laterally reversed

- ① Lamp on
- ② Switch for rear interior lamps
- ③ Automatic control

#### Manual control

**!** The rear interior lamps can be switched on with the SmartKey in starter switch position **0** or SmartKey removed from the starter switch for up to 30 minutes.

#### Switching interior lighting on

- ▶ Move switch ② to position ①.  
The rear interior lamp comes on.

#### Switching interior lighting off

- ▶ Move switch ② to center position.  
The rear interior lamp goes out.

#### Automatic control

#### Activating automatic control

- ▶ Move switch ② to position ③.  
The rear lamps come in darkness when you open a rear door.

#### Deactivating automatic control

- ▶ Move switch ② to center position.  
The rear lamps remain switched off in darkness, even when you open a rear door.

## Cargo compartment lamps

The switch for the cargo compartment lamps is located in the overhead control panel.



① Switch for cargo compartment lamps

The cargo compartment lamps are located above the rear window.

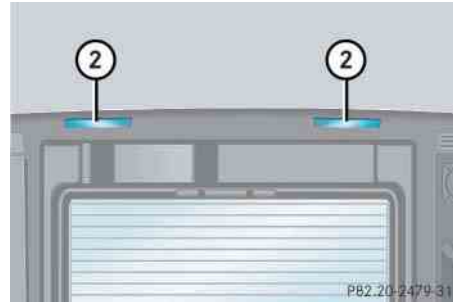

② Cargo compartment lamps

## Switching cargo compartment lamps on

► Press switch ①.

Cargo compartment lamps ② come on.

## Switching cargo compartment lamps off

► Press switch ① once more.

Cargo compartment lamps ② go out.

**i** When opening the tailgate, the cargo compartment lamps come on automatically. Switching off the cargo compartment lamps using switch ① in the overhead control panel (▷ page 127) then is not possible.

You can switch off the cargo compartment lamps if the tailgate should remain open for a longer period of time, see “Switching cargo compartment lamps off and on with the tailgate open” (▷ page 128).



### Lighting

#### Switching cargo compartment lamps off and on with the tailgate open

**!** To prevent the vehicle battery from being discharged, switch off the cargo compartment lamps if the tailgate should remain open for a longer period of time.



- ① Door lock
- ② Lock cylinder

#### Switching off

- ▶ Open the tailgate (▷ page 105).
- ▶ Press door lock ① down in direction of arrow until it engages.

**!** Do not close the tailgate if the lock is engaged in down position. The lock could otherwise be damaged.

When locking the tailgate, it is important that the door lock be in the same original position as shown in the illustration.

To return the door lock ① to its original position, press lock cylinder ②.

#### Switching on

- ▶ Press lock cylinder ② to activate the cargo compartment lamps again.

The cargo compartment lamps will come on.

#### Warning!



To prevent possible personal injury, always keep hands and fingers away from the tailgate opening when closing the tailgate. Be especially careful when small children are around.

Never drive vehicle with the tailgate open. Deadly carbon monoxide (CO) gases may enter vehicle interior resulting in unconsciousness and death.

## Door entry lamps

---

For better orientation in the dark, the corresponding door entry lamp comes on when you open a door and the automatic control is activated (> page 125).

The door entry lamp will switch off when the corresponding door is closed.

**i** *If you turn the SmartKey in the starter switch to position 0 and switch off the headlamps, the door entry lamps will remain lit for approximately 5 minutes.*

### Instrument cluster

For a full view on the instrument cluster, see “At a glance” (▷ page 26).



#### ① Reset button

The instrument cluster is activated when you

- open a door
- switch on the ignition (▷ page 39)
- press reset button ①
- switch on the exterior lamps (▷ page 117)

You can change the instrument cluster settings in the instrument cluster submenu of the control system (▷ page 149).

#### Warning!



No messages will be displayed if either the instrument cluster or the multifunction display is inoperative.

As a result, you will not be able to see information about your driving conditions, such as speed or outside temperature, warning/indicator lamps, malfunction/warning messages or the failure of any systems. Driving characteristics may be impaired.

If you must continue to drive, do so with added caution. Contact an authorized Mercedes-Benz Light Truck Center as soon as possible.

### Adjusting instrument cluster illumination

Use reset button ① to adjust the illumination brightness for the instrument cluster.

**i** *The instrument cluster illumination is dimmed or brightened automatically to suit ambient light conditions.*

*The instrument cluster illumination will also be adjusted automatically when you switch on the vehicle's exterior lamps.*

#### To brighten illumination

- ▶ Turn reset button ① clockwise until the desired level of illumination is reached.

#### To dim illumination

- ▶ Turn reset button ① counterclockwise until the desired level of illumination is reached.

## Coolant temperature gauge

The coolant temperature gauge is on the left side in the instrument cluster (▷ page 26).

### Warning!



- Driving when your engine is overheated can cause some fluids which may have leaked into the engine compartment to catch fire. You could be seriously burned.
- Steam from an overheated engine can cause serious burns which can occur just by opening the hood. Stay away from the engine if you see or hear steam coming from it.

Stop the vehicle in a safe location away from other traffic. Turn off the engine, get out of the vehicle and do not stand near the vehicle until the engine has cooled down.

**!** Excessive coolant temperature triggers a warning message in the multifunction display (▷ page 348).

*The engine should not be operated with the coolant temperature above 248°F (120°C). Doing so may cause serious engine damage which is not covered by the Mercedes-Benz Limited Warranty.*

**i** During severe operating conditions, e.g. stop-and-go traffic, the coolant temperature may rise close to 248°F (120°C).

## Resetting trip odometer

- ▶ Make sure you are viewing the standard display (▷ page 140).
- ▶ If it is not displayed, press button or on the multifunction steering wheel (▷ page 134) repeatedly until the standard display appears in the multifunction display.
- ▶ Press and hold reset button **①** (▷ page 130) until the trip odometer is reset.

#### Tachometer

The red marking on the tachometer (▷ page 26) denotes excessive engine speed.

**!** *Avoid driving at excessive engine speeds, as it may result in serious engine damage that is not covered by the Mercedes-Benz Limited Warranty.*

To help protect the engine, the fuel supply is interrupted if the engine is operated within the red marking.

#### Outside temperature indicator

##### Warning!



The outside temperature indicator is not designed to serve as an ice-warning device and is therefore unsuitable for that purpose.

Indicated temperatures just above the freezing point do not guarantee that the road surface is free of ice. The road may still be icy, especially in wooded areas or on bridges.

The outside temperature is displayed in the multifunction display (▷ page 133).

The temperature sensor is located in the front bumper area. Due to its location, the sensor can be affected by road or engine heat during idling or slow driving. This means that the accuracy of the displayed temperature can only be verified by comparison to a thermometer placed next to the sensor, not by comparison to external displays (e.g. bank signs, etc.).

When moving the vehicle into colder ambient temperatures (e.g. when leaving your garage), you will notice a delay before the lower temperature is displayed.

A delay also occurs when ambient temperatures rise. This prevents inaccurate temperature indications caused by heat radiated from the engine during idling or slow driving.

### ▼ Control system

The control system is activated as soon as the SmartKey in the starter switch is turned to position **1**. The control system enables you to

- call up information about your vehicle
- change vehicle settings

For example, you can use the control system to find out when your vehicle is next due for maintenance service, to set the language for messages in the instrument cluster display, and much more.

### Warning!



A driver's attention to the road and traffic conditions must always be his/her primary focus when driving.

For your safety and the safety of others, selecting features through the multifunction steering wheel should only be done by the driver when traffic and road conditions permit it to be done safely.

Bear in mind that at a speed of just 30 mph (approximately 50 km/h), your vehicle is covering a distance of 44 feet (approximately 14 m) every second.

The control system relays information to the multifunction display.

### Multifunction display



- ① Trip odometer
- ② Main odometer
- ③ Transfer case indicator
- ④ Current gear selector lever position/gear range
- ⑤ Status indicator (clock)
- ⑥ Status indicator (outside temperature or digital speedometer)

For more information on menus displayed in the multifunction display, see “Menus” (▷ page 136).

## Control system

### Multifunction steering wheel

The displays in the multifunction display and the settings in the control system are controlled by the buttons on the multifunction steering wheel.



#### ① Multifunction display

#### Operating the control system

#### ② Selecting a submenu or setting the volume:

Press button

**+** up / to increase

**-** down / to decrease

#### ③ Telephone\*:

Press button

 to take a call  
to dial  
to redial

 to end a call  
to reject an incoming call

#### ④ Menu systems:

Press button

 for next menu

 for previous menu

#### ⑤ Moving within a menu:

Press button

 for next display

 for previous display

#### Canada vehicles:

*The steering wheel in this vehicle may vary from steering wheel shown. However, multifunction steering wheel symbols and feature description apply to Canada vehicles as well.*

#### G 55 AMG:





*The steering wheel in this vehicle may vary from steering wheel shown. However, multifunction steering wheel symbols and feature description apply to AMG vehicles as well.*

Depending on the selected menu, pressing the buttons on the multifunction steering wheel will alter what is shown in the multifunction display.

The information available in the multifunction display is arranged in menus, each containing a number of functions or submenus.

The individual functions are then found within the relevant menu (radio or CD operations under *Audio*, for example). These functions serve to call up relevant information or to customize the settings for your vehicle.

It is helpful to think of the menus, and the functions within each menu, as being arranged in a circular pattern.

- If you press button  or  repeatedly, you will pass through each menu one after the other.
- If you press button  or  repeatedly, you will pass through each function display, one after the other, in the current menu.

In the *Settings* menu, instead of functions, you will find a number of submenus for calling up and changing settings. For instructions on using these submenus, see “Settings menu” (▷ page 146).

The number of menus available in the system depends on which optional equipment is installed in your vehicle.

The menus are described on the following pages.



## Control system

### Menus

This is what you will see when you scroll through the menus ① to ④.

The table on the next page provides an overview of the individual menus.

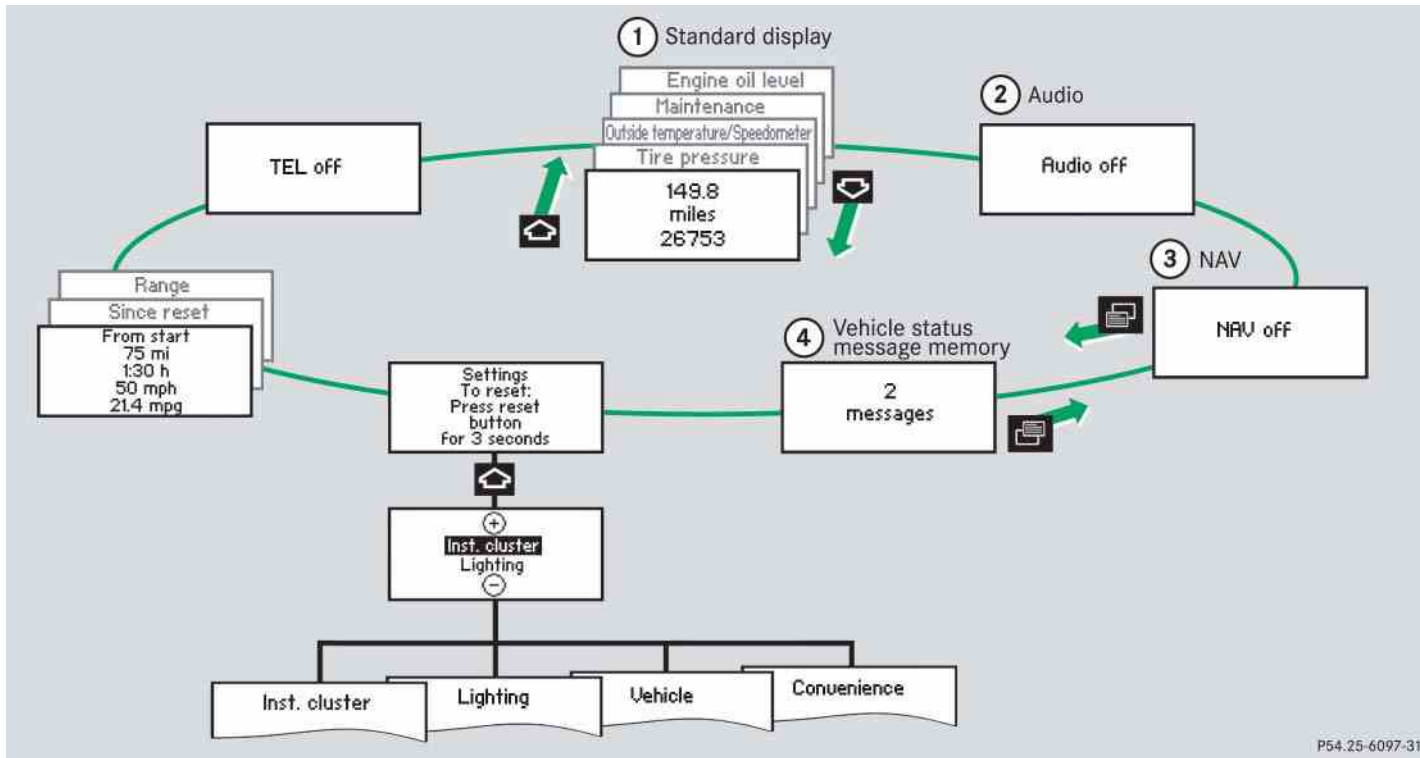

Menus, submenus and functions

|                  | Menu ①<br>Standard display<br>(▷ page 140)            | Menu ②<br>Audio<br>(▷ page 141)               | Menu ③<br>NAV<br>(▷ page 144)                           | Menu ④<br>Vehicle status message memory <sup>1</sup><br>(▷ page 144)                           |
|------------------|---|---|---|--|
| Commands/submenu | Trip- and main odometer                               | Selecting radio station                       | Route guidance instructions, current direction traveled | Calling up malfunction messages, warning messages, and system status messages stored in memory |
|                  | Checking tire inflation pressure                      | Selecting satellite radio station* (USA only) |   |  |
|                  | Calling up digital speedometer or outside temperature | Operating CD player                           |   |  |
|                  | Calling up maintenance service indicator              |   |   |  |
|                  | Checking engine oil level                             |   |   |  |

<sup>1</sup> The vehicle status message memory menu is only displayed if there is a message stored.

**i** The headings used in the menus table are designed to facilitate navigation within the system and are not necessarily identical to those shown in the control system displays.

The first function displayed in each menu will automatically show you which part of the system you are in.

## Control system

This is what you will see when you scroll through the menus ⑤ to ⑦.

The table on the next page provides an overview of the individual menus.

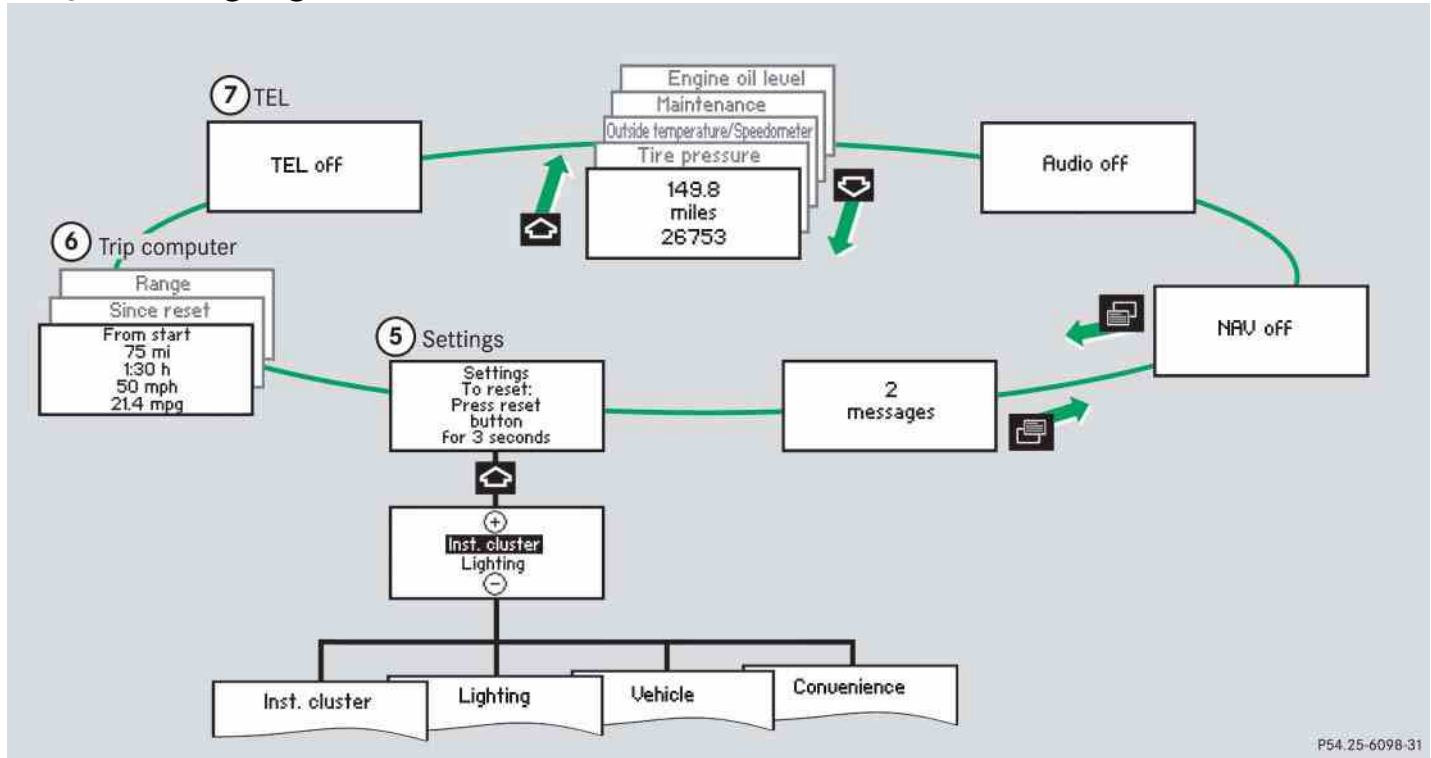

Menus, submenus and functions

|                  | Menu ⑤<br>Settings<br>(▷ page 146) | Menu ⑥<br>Trip computer<br>(▷ page 157)      | Menu ⑦<br>TEL<br>(▷ page 159)    |
|------------------|------------------------------------|--|----------------------------------|
| Commands/submenu | Resetting to factory settings      | Fuel consumption statistics since start      | Loading phone book               |
|                  | Instrument cluster submenu         | Fuel consumption statistics since last reset | Searching for name in phone book |
|                  | Lighting submenu                   | Resetting fuel consumption statistics        |                                  |
|                  | Vehicle submenu                    | Distance to empty                            |                                  |
|                  | Convenience submenu                |  |                                  |

**i** The headings used in the menus table are designed to facilitate navigation within the system and are not necessarily identical to those shown in the control system displays.

The first function displayed in each menu will automatically show you which part of the system you are in.

## Control system

### Standard display menu





In the standard display, the main odometer and the trip odometer appear in the multifunction display.



### Standard display

- ① Trip odometer
- ② Main odometer



If you see another display instead of the standard display:

- ▶ Press button  or  repeatedly until the standard display appears in the multifunction display.
- ▶ Press button  or  to select the functions in the standard display menu.

The following functions are available:

| Function  | Page |
|---|------|
| Checking tire inflation pressure                      | 288  |
| Calling up digital speedometer or outside temperature | 140  |
| Calling up maintenance service indicator              | 313  |
| Checking engine oil level                             | 270  |

### Calling up digital speedometer or outside temperature

- ▶ Press button  or  repeatedly until the digital speedometer or the outside temperature appears in the multifunction display.



### Digital speedometer



### Outside temperature

**i** You can select whether the digital speedometer or the outside temperature is to be displayed.

You can change the setting in the submenu Inst. cluster via the function Status line display, see "Selecting display (digital speedometer or outside temperature) for status indicator" (▷ page 150).

### Audio menu



The functions in the Audio menu operate the audio equipment which you currently have turned on.

If no audio equipment is currently turned on, the message Audio off appears in the multifunction display.

The following functions are available:

| Function                                      | Page |
|---|------|
| Selecting radio station                       | 141  |
| Selecting satellite radio station* (USA only) | 142  |
| Operating CD player                           | 143  |

### Selecting radio station

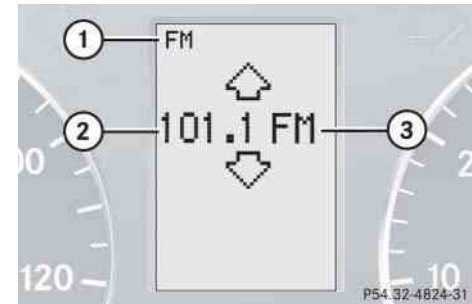

- ▶ Turn on the COMAND system and select radio. Refer to separate COMAND system operating instructions.
- ▶ Press button  or  repeatedly until the currently tuned station appears in the multifunction display.





- ① Waveband setting or stored memory position (FM0 through FM9)
- ② Station frequency
- ③ Waveband setting



### Control system

- ▷▷ Press button  or  repeatedly until a station or the desired stored station is found.



The station search depends on the selected setting in the **Vehicle** submenu, see “Selecting audio search function” (▷ page 155).

Pressing button  or  will either start a frequency scan or select the next stored radio station.

**i** You can only store new stations using the corresponding feature on the radio. Refer to separate COMAND system operating instructions. You can also operate the radio in the usual manner.



### Selecting satellite radio station\* (USA only)

The satellite radio is treated as a radio application.

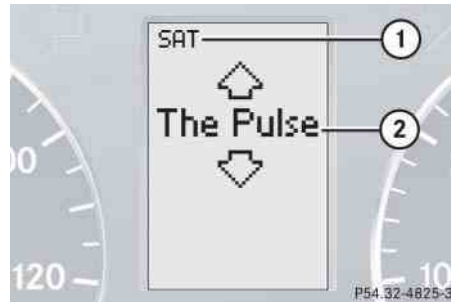
- ▶ Select satellite radio with the corresponding soft key on the COMAND system.
- ▶ Press button  or  repeatedly until the currently tuned station appears in the multifunction display.



- ① SAT mode or preset number (SAT0 through SAT9)
- ② Channel name or number

- ▶ Press button  or  repeatedly until the desired channel is found.

**i** Additional optional satellite radio equipment and a subscription to satellite radio service provider are required for satellite radio operation. Contact an authorized Mercedes-Benz Light Truck Center for details and availability for your vehicle.



For more information, refer to separate COMAND system operating instructions.

**i** Satellite radio service may be unavailable or interrupted from time to time for a variety of reasons, such as environmental or topographic conditions and other things beyond the service provider's or our control. Service might also not be available in certain places (e.g. in tunnels, parking garages, or within or next to buildings) or near other technologies.



### Operating the CD player

**i** The COMAND system and the CD changer can play CDs as well as MP3-CDs.

#### Selecting CD track

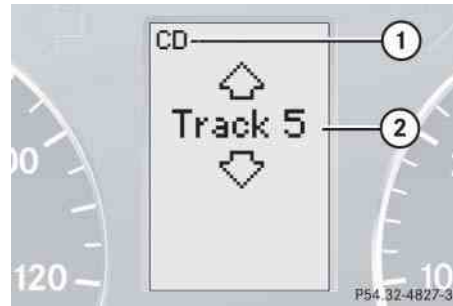
- ▶ Turn on the COMAND system and select CD. Refer to separate COMAND system operating instructions.
- ▶ Press button  or  repeatedly until the settings for the CD currently being played appear in the multifunction display.





- ① Current CD (CD0 for CD in head unit, CD1 through CD6 for CD in CD changer)
  - ② Current track
- ▶ Press button  or  repeatedly until the desired track is selected.

**i** To select a CD from the CD changer magazine, press a number on the COMAND system key pad located in the center console.

#### Selecting MP3-CD track

- ▶ Turn on the COMAND system and select MP3. Refer to separate COMAND system operating instructions.

**i** A MP3-CD inserted in the CD changer is handled by the COMAND system like an audio CD. Information contained on a MP3-CD will not appear in the multifunction display or in the COMAND system display.

- ▶ Press button  or  repeatedly until the settings for the MP3-CD currently being played appear in the multifunction display.





### Control system

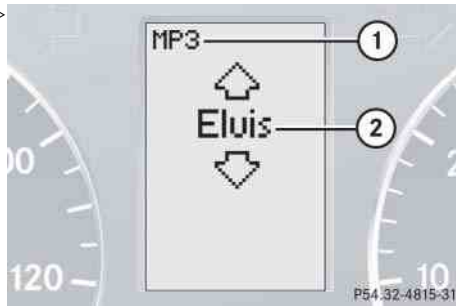

- ① MP3 mode
- ② Current track



▶ Press button  or  repeatedly until the desired track is selected.

**i** Level of information displayed will vary depending on the information contained on the MP3-CD inserted in the single CD drive of the COMAND system.

To select a MP3-CD from the CD changer magazine, press a number on the COMAND system key pad located in the center console.

### NAV menu

The NAV menu contains the functions needed to operate your navigation system.

▶ Press button  or  repeatedly until the message NAV appears in the multifunction display.

The message shown in the multifunction display depends on the status of the navigation system:

- With the navigation system switched off, the message NAV off appears in the multifunction display.
- With the navigation system switched on but route guidance not activated, the direction of travel and, if applicable, the name of the street currently traveled on appear in the multifunction display.

- With the navigation system switched on and route guidance activated, the direction of travel and maneuver instructions appear in the multifunction display.

Please refer to the COMAND system manual for instructions on how to activate the route guidance system.



### Vehicle status message memory menu

Use the vehicle status message memory menu to scan malfunction and warning messages that may be stored in the system. Such messages appear in the multifunction display and are based on conditions or system status the vehicle's system has recorded.

The vehicle status message memory menu only appears, if messages have been stored.

**Warning!**

Malfunction and warning messages are only indicated for certain systems and are intentionally not very detailed. The malfunction and warning messages are simply a reminder with respect to the operation of certain systems and do not replace the owner's and/or driver's responsibility to maintain the vehicle's operating safety by having all required maintenance and safety checks performed on the vehicle and by bringing the vehicle to an authorized Mercedes-Benz Light Truck Center to address the malfunction and warning messages (▷ page 338).

- ▶ Press button  or  repeatedly until the vehicle status message memory appears in the multifunction display.

If conditions have occurred causing status messages to be recorded, the number of messages appears in the multifunction display:

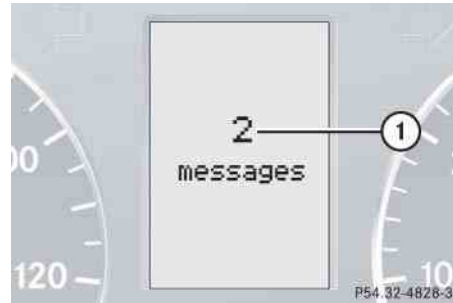

① Number of messages

- ▶ Press button  or .

The stored messages will now be displayed in the order in which they have occurred. For malfunction and warning messages, see “Vehicle status messages in the multifunction display” (▷ page 338).

**i** After you have scrolled through all recorded status messages, the first recorded message appears again.



Should the vehicle's system record any conditions while driving, the number of messages will reappear in the multifunction display when the SmartKey in the starter switch is turned to position **0** or removed from the starter switch.

**i** The vehicle status message memory will be cleared when you turn the SmartKey in the starter switch to position **1** or **2**. You will then only see high-priority messages in the multifunction display (▷ page 338).

## Control system

### Settings menu

In the Settings menu there are two functions:

- The function **Reset to factory settings**, with which you can reset all the settings to the original factory settings.
  - A collection of submenus with which you can make individual settings for your vehicle.
- ▶ Press button  or  repeatedly until the **Settings** menu appears in the multifunction display.

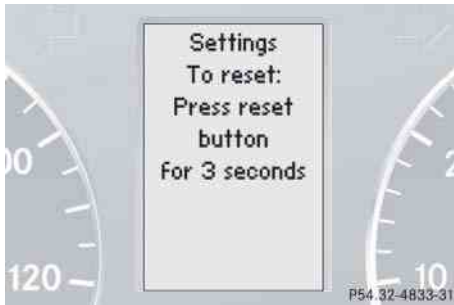

The following settings and submenus are available in the **Settings** menu:

| Function                      | Page |
|-------------------------------|------|
| Resetting all settings        | 146  |
| Submenus in the settings menu | 147  |
| Instrument cluster submenu    | 149  |
| Lighting submenu              | 151  |
| Vehicle submenu               | 154  |
| Convenience submenu           | 156  |

### Resetting all settings

You can reset the functions of all submenus to the factory settings.

- ▶ Press the reset button in the instrument cluster (▷ page 130) for approximately 3 seconds.

The request to press the reset button once more to confirm appears in the multifunction display.

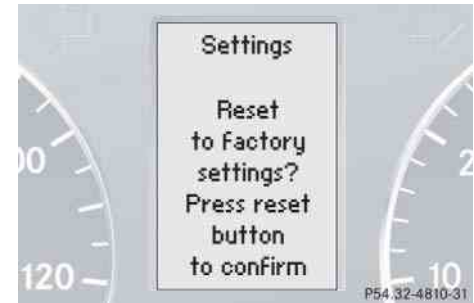

- ▶ Press the reset button once more.

The functions of all submenus will reset to factory settings.

**i** The settings you have changed will not be reset unless you confirm the action by pressing the reset button a second time.

After approximately 5 seconds, the Settings menu reappears in the multifunction display (▷ page 146).

**i** For safety reasons, the function Headlamp mode in the Lighting submenu cannot be reset while driving.

The following message appears in the multifunction display:

Settings  
Cannot be completely  
reset to factory  
settings while driving

### Submenus in the Settings menu



► Press button .

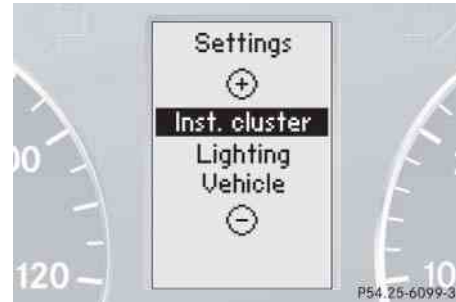

The collection of the submenus appears in the multifunction display.





► Press button .

The selection marker moves to the next submenu.

The submenus are arranged by hierarchy. Scroll down with button , scroll up with button .

With the selection marker on the desired submenu, use button  to access the individual functions within that submenu. Once within that submenu, you can use button  to move to the next function or button  to move to the previous function within that menu.

The settings themselves are made with button  or .

### Control system

The table below shows what settings can be changed within the various menus. Detailed instructions on making individual settings can be found on the following pages.

| <b>Instrument cluster</b>   | <b>Lighting</b>                              | <b>Vehicle</b>                  | <b>Convenience</b>                 |
|---|--|---------------------------------|------------------------------------|
| (▷ page 149)  | (▷ page 151)                                 | (▷ page 154)                    | (▷ page 156)                       |
| Selecting speedometer display mode  | Setting daytime running lamp mode (USA only) | Selecting audio search function | Activating easy-entry/exit feature |
| Selecting language  | Setting locator lighting                     | Setting automatic locking       |                                    |
| Selecting display (digital speedometer or outside temperature) for status indicator | Setting night security illumination          |                                 |                                    |
|   | Setting interior lighting delayed shut-off   |                                 |                                    |

### Instrument cluster submenu

Access the Inst. cluster submenu via the Settings menu. Use the Inst. cluster submenu to change the instrument cluster display settings.

The following functions are available:

| Function  | Page |
|---|------|
| Selecting speedometer display mode  | 149  |
| Selecting language  | 149  |
| Selecting display (digital speedometer or outside temperature) for status indicator | 150  |

### Selecting speedometer display mode

- ▶ Move the selection marker with button **+** or **-** to the Inst. cluster submenu.
- ▶ Press button **▲** or **▼** repeatedly until the message **Disp.Unit Speed-/odometer.** appears in the multifunction display.

The selection marker is on the current setting.



- ▶ Press button **+** or **-** to set speedometer unit to km or miles.

### Selecting language

- ▶ Move the selection marker with button **+** or **-** to the Inst. cluster submenu.
- ▶ Press button **▲** or **▼** repeatedly until the message **Language** appears in the multifunction display.

The selection marker is on the current setting.



### Control system

- ▷▷ Press button **+** or **-** to select the language to be used for the multifunction display messages.

Available languages:

- German
- English
- French
- Italian
- Spanish

### **Selecting display (digital speedometer or outside temperature) for status indicator**

- ▶ Move the selection marker with button **+** or **-** to the Inst. cluster submenu.
- ▶ Press button **▲** or **▼** repeatedly until the message Status line display appears in the multifunction display.

The selection marker is on the current setting.

- ▶ Press button **+** or **-** to select the desired setting.

The selected display is then shown continuously in the status indicator (▷ page 133).

The other display now appears in the menu of the standard display (▷ page 140):

- Digital speedometer  
or
- Outside temperature

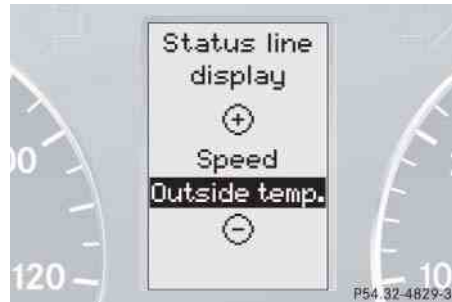

### Lighting submenu

Access the Lighting submenu via the Settings menu. Use the Lighting submenu to change the lamp and lighting settings on your vehicle.

The following functions are available:

| Function                                     | Page |
|--|------|
| Setting daytime running lamp mode (USA only) | 151  |
| Setting locator lighting                     | 152  |
| Setting night security illumination          | 153  |
| Setting interior lighting delayed shut-off   | 154  |

### Setting daytime running lamp mode (USA only)

**i** Canada vehicles:

*This function is not available as the daytime running lamp mode is mandatory and therefore in a constant mode.*

- ▶ Move the selection marker with button **+** or **-** to the Lighting submenu.
- ▶ Press button **↶** or **↷** repeatedly until the message Headlamp mode appears in the multifunction display.

The selection marker is on the current setting.

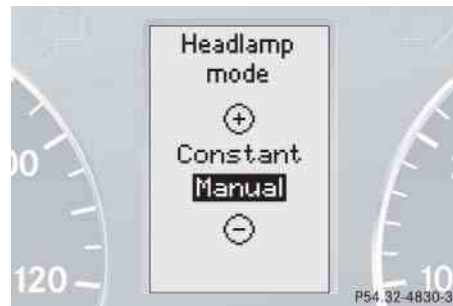

- ▶ Press button **+** or **-** to select manual operation (Manual) or daytime running lamp mode (Constant).

With daytime running lamp mode activated and the exterior lamp switch in position **0** or **AUTO**, the low beam headlamps are switched on when the engine is running.

In low ambient light conditions the following lamps will switch on additionally:

- Parking lamps
- Tail lamps
- License plate lamps
- Side marker lamps



### Control system

**i** For safety reasons, changing the setting for the daytime running lamp mode is not possible while the vehicle is in motion. The following message appears in the multifunction display:

Setting can only be made at a standstill

For safety reasons, resetting to factory settings (▷ page 146) while driving will not deactivate the daytime running lamp mode.

For more information on the daytime running lamp mode, see “Lighting” (▷ page 117).

#### Setting locator lighting

With the locator lighting feature activated and the exterior lamp switch in position **AUTO** (▷ page 117), the following lamps will switch on during darkness when the vehicle is unlocked using button **U** on the SmartKey:

- Parking lamps
- Tail lamps
- License plate lamps
- Side marker lamps
- Front fog lamps

The locator lighting switches off when the driver’s door is opened.

If you do not open a door after unlocking the vehicle with the SmartKey, the lamps will switch off automatically after approximately 40 seconds.

- ▶ Move the selection marker with button **+** or **-** to the Lighting submenu.

- ▶ Press button **↶** or **↷** repeatedly until the message Surround lighting appears in the multifunction display.

The selection marker is on the current setting.



- ▶ Press button **+** or **-** to switch the locator lighting function On or Off.
- ▶ Turn the exterior lamp switch to position **AUTO** when exiting the vehicle.

The locator lighting feature is activated.

### Setting night security illumination (Headlamps delayed shut-off)

Use this function to set whether you would like the exterior lamps to remain on for 15 seconds during darkness after exiting the vehicle and closing all doors.

With the headlamps delayed shut-off feature activated and the exterior lamp switch in position **AUTO** before the engine is turned off, the following lamps will switch on when the engine is turned off:

- Parking lamps
- Tail lamps
- License plate lamps
- Side marker lamps
- Front fog lamps

If after turning off the engine you do not open a door or do not close an opened door, the lamps will automatically switch off after approximately 60 seconds.

- ▶ Move the selection marker with button **+** or **-** to the Lighting submenu.
- ▶ Press button **↶** or **↷** repeatedly until the message **Headl. delayed shut-off** appears in the multifunction display.

The selection marker is on the current setting.

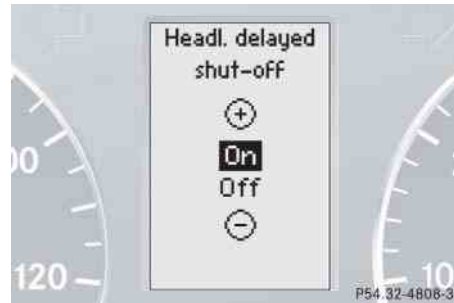

- ▶ Press button **+** or **-** to switch the headlamps delayed shut-off feature **On** or **Off**.

- ▶ Turn the exterior lamp switch to position **AUTO** before turning off the engine.

The headlamps delayed shut-off feature is activated.

You can temporarily deactivate the headlamps delayed shut-off feature:

- ▶ Before exiting the vehicle, turn the SmartKey in the starter switch to position **0**.
- ▶ Then turn it to position **2** and back to position **0**.

The headlamps delayed shut-off feature is deactivated. It will reactivate as soon as you reinsert the SmartKey in the starter switch.

### Control system

#### ***Setting interior lighting delayed shut-off***

Use this function to set whether you would like the interior lighting to remain on for 10 seconds during darkness after you have removed the SmartKey from the starter switch.

- ▶ Move the selection marker with button **+** or **-** to the Lighting submenu.
- ▶ Press button **▲** or **▼** repeatedly until the message Interior light. delay.sw.off appears in the multifunction display.

The selection marker is on the current setting.



- ▶ Press button **+** or **-** to switch the interior lighting delayed shut-off feature On or Off.

#### **Vehicle submenu**

Access the Vehicle submenu via the Settings menu. Use the Vehicle submenu to make general vehicle settings.

The following functions are available:

| Function                        | Page |
|---------------------------------|------|
| Selecting audio search function | 155  |
| Setting automatic locking       | 155  |

### Selecting audio search function

Use of the audio search function to select a radio station (▷ page 141) will enable you to start a frequency scan (Frequency) or select a radio station stored in memory (Memory).

- ▶ Move the selection marker with button **+** or **-** to the Vehicle submenu.
- ▶ Press button **↕** or **↘** repeatedly until the message **Audio search** appears in the multifunction display.

The selection marker is on the current setting.

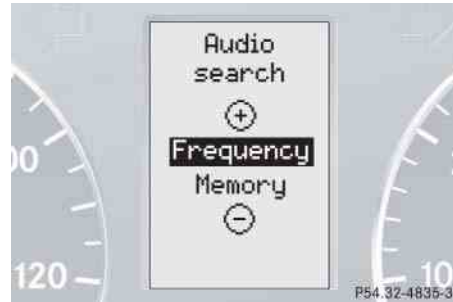

- ▶ Press button **+** or **-** to select Frequency or Memory.

### Setting automatic locking

Use this function to activate or deactivate the automatic central locking. With the automatic central locking system activated, the vehicle is centrally locked at vehicle speeds of approximately 9 mph (15 km/h).

- ▶ Move the selection marker with button **+** or **-** to the Vehicle submenu.
- ▶ Press button **↕** or **↘** repeatedly until the message **Automatic door lock** appears in the multifunction display.

▷▷

### Control system

- ▷▷ The selection marker is on the current setting.



- ▶ Press button **+** or **-** to switch the automatic central locking On or Off.

#### Convenience submenu

Access the Convenience submenu via the Settings menu. Use the Convenience submenu to change the setting for the convenience feature.

The following function is available:

| Function                           | Page |
|------------------------------------|------|
| Activating easy-entry/exit feature | 156  |

#### Activating easy-entry/exit feature

Use this function to activate and deactivate the easy-entry/exit feature (▷ page 45).

#### Warning!



You must make sure no one can become trapped or injured by the moving steering wheel when the easy-entry/exit feature is activated.

To stop steering wheel movement, do one of the following:

- Move the steering wheel adjustment stalk (▷ page 44).
- Press one of the stored position buttons or the memory button (▷ page 115).

Do not leave children unattended in the vehicle, or with access to an unlocked vehicle. Children could open the driver's door and unintentionally activate the easy-entry/exit feature, which could result in an accident and/or serious personal injury.

- ▶ Move the selection marker with button **+** or **-** to the Convenience submenu.
- ▶ Press button **↶** or **↷** repeatedly until the message **Easy-entry feature** appears in the multifunction display.

The selection marker is on the current setting.



- ▶ Press button **+** or **-** to switch the easy-entry/exit feature On or Off.

### Trip computer menu

Use the trip computer menu to call up statistical data on your vehicle.

The following information is available:

| Function                                     | Page |
|--|------|
| Fuel consumption statistics since start      | 157  |
| Fuel consumption statistics since last reset | 158  |
| Resetting fuel consumption statistics        | 158  |
| Distance to empty                            | 158  |

**i** When you enter the trip computer menu, you will always see the fuel consumption statistics from start first.

### Fuel consumption statistics since start

- ▶ Press button **☰** or **☷** repeatedly until the message **From start** appears in the multifunction display.

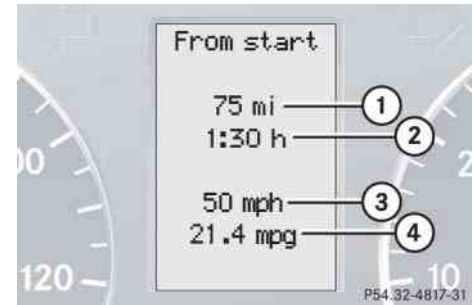





- ① Distance driven since start
- ② Time elapsed since start
- ③ Average speed since start
- ④ Average fuel consumption since start

**i** All statistics stored since the last engine start will be reset approximately 4 hours after the SmartKey in the starter switch is turned to position **0** or removed from the starter switch. Resetting will not occur if you turn the SmartKey back to position **1** or **2** within this time period.

## Control system



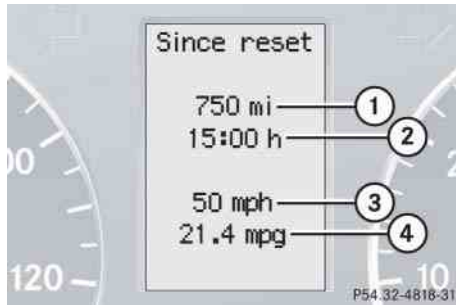

### Fuel consumption statistics since last reset

- ▶ Press button  or  repeatedly until the message **From start** appears in the multifunction display.
- ▶ Press button  or  repeatedly until the message **Since reset** appears in the multifunction display.



- ① Distance driven since last reset
- ② Time elapsed since last reset
- ③ Average speed since last reset
- ④ Average fuel consumption since last reset

### Resetting fuel consumption statistics

- ▶ Press button  or  repeatedly until the message **From start** appears in the multifunction display.
- ▶ Press button  or  repeatedly until the reading that you want to reset appears in the multifunction display.
- ▶ Press and hold the reset button in the instrument cluster (▶ page 130) until the value is reset to 0.





**i** The fuel consumption statistics **From start** reset automatically to 0 when either of the following values is exceeded:

- distance covered: 9999 miles
- time elapsed: 999 hours

The fuel consumption statistics **Since reset** reset automatically to 0 when either of the following values is exceeded:

- distance covered: 99999 miles
- time elapsed: 9999 hours

### Distance to empty

- ▶ Press button  or  repeatedly until the message **From start** appears in the multifunction display.
- ▶ Press button  or  repeatedly until the message **Range** appears in the multifunction display.

The calculated remaining driving range based on the current fuel tank level appears in the multifunction display.



**i** If only very little fuel is left in the fuel tank, the message **Range: ---** appears in the multifunction display.

## TEL menu

### Warning!





A driver's attention to the road and traffic conditions must always be his/her primary focus when driving. For your safety and the safety of others, we recommend that you pull over to a safe location and stop before placing or taking a telephone call. If you choose to use the telephone while driving, please use the hands-free device and only use the telephone when weather, road and traffic conditions permit.

Some jurisdictions prohibit the driver from using a cellular telephone while driving a vehicle.

Bear in mind that at a speed of just 30 mph (approximately 50 km/h), your vehicle is covering a distance of 44 feet (approximately 14 m) every second.

Never operate radio transmitters equipped with a built-in or attached antenna (i.e. without being connected to an external antenna) from inside the vehicle while the engine is running. Doing so could lead to a malfunction of the vehicle's electronic system, possibly resulting in an accident and/or personal injury.

You can use the functions in the TEL menu to operate your telephone, provided it is connected to a hands-free system and switched on.

- ▶ Switch on the telephone and COMAND system.
- ▶ Press button  or  on the multifunction steering wheel repeatedly until the message TEL appears in the multifunction display.

Which messages will appear in the multifunction display depends on whether your telephone is switched on or off:

- If the telephone is off, the message TEL off appears in the multifunction display.
- If the telephone is on:

The telephone will then search for a network. During this time the multifunction display is empty.

As soon as the telephone has found a network, the message Ready appears in the multifunction display.





### Control system

This standby message indicates that your telephone is ready for use and you can operate it using the control system.

#### Answering a call

When your telephone is ready to receive calls, you can answer a call at any time. In the multifunction display you will then see the message:



- ▶ Press button .





You have answered the call. The duration of the call appears in the multifunction display.

#### Ending a call or rejecting an incoming call

- ▶ Press button .



#### Dialing a number from the phone book

If your telephone is ready to receive calls, you may select and dial a number from the phone book at any time.

- ▶ Press button  or  repeatedly until the message TEL appears in the multifunction display.
- ▶ Press button  or .

The control system reads the phone book which is stored in the telephone. This may take several minutes. The message *Please wait* appears in the multifunction display.



When the message *Please wait* disappears, the phone book has been loaded.

- ▶ Press button  or  repeatedly until the desired name appears in the multifunction display.

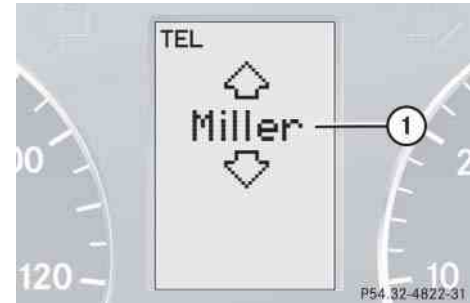
The stored names are displayed in ascending or descending alphabetical order.



- ① Name from the phone book

**i** If you press and hold button  or  for longer than 1 second, the system scrolls rapidly through the list of names until you release the button again.

Cancel the quick search mode by pressing button .

- ▶ Press button .

The system dials the selected phone number.



- If connection is successful and this feature is supported by your network provider, the name of the party you are calling (if stored in your phone book) and the duration of the call will appear in the multifunction display.





- If no connection is made, the control system stores the dialed number in the redial memory.

### Redialing

The control system stores the most recently dialed phone numbers. This eliminates the need to search through your entire phone book.

- ▶ Press button  or  repeatedly until the message TEL appears in the multifunction display.
- ▶ Press button .

The first number in the redial memory appears in the multifunction display.

- ▶ Press button  or  repeatedly until the desired name appears in the multifunction display.

- ▶ Press button .

The control system dials the selected phone number.

### Automatic transmission

For more information on driving with an automatic transmission, see “Automatic transmission” (▷ page 54).

Your vehicle’s transmission adapts its gear shifting process to your individual driving style by continually adjusting the shift points up or down. These shift point adjustments are performed based on current operating and driving conditions.

If the operating conditions change, the automatic transmission reacts by adjusting its shift program.

**i** During the brief warm-up, transmission upshifting is delayed. This allows the catalytic converter to heat up more quickly to operating temperature.

#### Warning!



Make sure that absolutely no objects are obstructing the pedal’s range of movement. Keep the driver’s footwell clear of all obstacles. If there are any floor mats or carpets in the footwell, make sure that the pedals still have sufficient clearance.

During sudden driving or braking maneuvers the objects could get caught between the pedals. You could then no longer brake or accelerate. This could lead to accidents and injury.

#### Gear selector lever

The gear selector lever is located on the lower part of the center console.

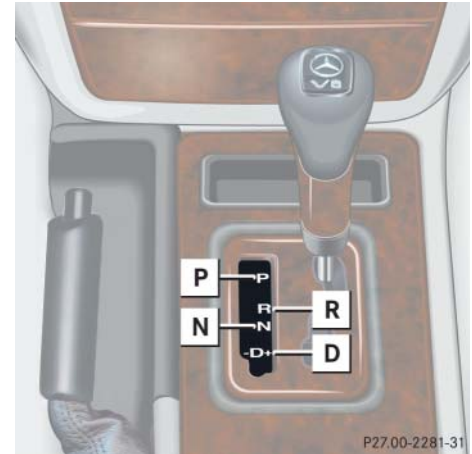

#### Gearshift pattern for automatic transmission

- P** Park position
- R** Reverse gear
- N** Neutral position
- D** Drive position

 The current gear selector lever position **P**, **R**, **N**, or **D** appears in the multifunction display (▷ page 164).

### Warning!



It is dangerous to shift the gear selector lever out of park position **P** or neutral position **N** if the engine speed is higher than idle speed. If your foot is not firmly on the brake pedal, the vehicle could accelerate quickly forward or reverse. You could lose control of the vehicle and hit someone or something. Only shift into gear when the engine is idling normally and when your right foot is firmly on the brake pedal.

### Shifting procedure

The automatic transmission selects individual gears automatically, depending on:

- gear selector lever position **D** (▷ page 164) with gear ranges (▷ page 167)
- transfer case position (**HIGH** or **LOW**) (▷ page 170)
- the position of the accelerator pedal (▷ page 166)
- the vehicle speed

 Allow engine to warm up under low load use. Do not place full load on the engine until the operating temperature has been reached.

Shift into reverse gear **R** or park position **P** only when the vehicle is stopped.

When the gear selector lever is in drive position **D**, you can influence transmission shifting by:

- limiting the gear range
- changing gears manually

## Automatic transmission

### Gear selector lever positions

The current gear selector lever position appears in the multifunction display.



① Current gear selector lever position

#### Effect

##### **P** Park position

Gear selector lever position when the vehicle is parked. Place gear selector lever in park position **P** only when vehicle is stopped. The park position is not intended to serve as a brake when the vehicle is parked. Rather, the driver should always set the parking brake in addition to placing the gear selector lever in park position **P** to secure the vehicle.

#### Effect

The SmartKey can only be removed from the starter switch with the gear selector lever in park position **P**. With the SmartKey removed, the gear selector lever is locked in park position **P**.

If the vehicle's electrical system is malfunctioning, the gear selector lever could remain locked in park position **P** (▷ page 373).

##### **R** Reverse gear

Place gear selector lever in position **R** only when vehicle is stopped.

|          | Effect  |
|----------|---|
| <b>N</b> | <p><b>Neutral</b></p> <p>No power is transmitted from the engine to the drive axle. When the brakes are released, the vehicle can be moved freely (pushed or towed).</p> <p>To avoid damage to the transmission, never engage neutral position <b>N</b> while driving except:</p> <ul style="list-style-type: none"> <li>to coast when vehicle is in danger of skidding (e.g. on icy roads) when the ESP® is deactivated or malfunctioning</li> <li>when you have to shift the transfer case</li> </ul> |
| <b>D</b> | <p><b>Drive</b></p> <p>The transmission shifts automatically. All forward gears are available.</p>  |

**!** *Coasting the vehicle, or driving for any other reason with gear selector lever in neutral position **N** can result in transmission damage that is not covered by the Mercedes-Benz Limited Warranty.*

**Warning!**



Getting out of your vehicle with the gear selector lever not fully engaged in park position **P** is dangerous. Also, park position **P** alone is not intended to or capable of preventing your vehicle from moving, possibly hitting people or objects.

Always set the parking brake in addition to shifting to park position **P** (> page 62).

When parked on an incline, turn the front wheels towards the road curb.

Do not park this vehicle in areas where combustible materials such as grass, hay or leaves can come into contact with the hot exhaust system, as these materials could be ignited and cause a vehicle fire.

**Warning!**



When leaving the vehicle, always remove the SmartKey from the starter switch, take it with you, and lock the vehicle. Do not leave children unattended in the vehicle, or with access to an unlocked vehicle. Children could move the gear selector lever from park position **P**, which could result in an accident and/or serious personal injury.

### Automatic transmission

#### Driving tips

---

##### Accelerator position

Your driving style influences the transmission's shifting behavior:

|               |                    |
|---------------|--------------------|
| Less throttle | Earlier upshifting |
| More throttle | Later upshifting   |

##### Kickdown

Use kickdown when you want maximum acceleration.

- ▶ Press the accelerator past the point of resistance.

Depending on the engine speed the transmission shifts into a lower gear.

- ▶ Ease on the accelerator when you have reached the desired speed.

The transmission shifts up again.

#### Stopping

When you stop briefly, e.g. at traffic lights:

- ▶ Leave the transmission in gear.
- ▶ Hold the vehicle with the brake.

When you stop for a longer period of time with the engine idling and/or on a hill:

- ▶ Set the parking brake.
- ▶ Move the gear selector lever to park position **P**.

#### Maneuvering

When you maneuver in tight areas, e.g. when pulling into a parking space:

- ▶ Control the vehicle speed by gradually releasing the brakes.
- ▶ Accelerate gently.
- ▶ Never abruptly step on the accelerator.

#### Working on the vehicle

##### Warning!



When working on the vehicle, set the parking brake and move gear selector lever to park position **P**. Otherwise the vehicle could roll away.

### Gear ranges

With the gear selector lever in drive position **D**, you can select a gear range for the automatic transmission to operate within.

You can limit the gear range by pressing the gear selector lever to the left (**D-**), and reverse the gear range limit by pressing the gear selector lever to the right (**D+**) (> page 168).

The current gear range appears in the multifunction display.



① Current gear range

**!** If the transfer case is in off-road driving position **LOW**, the automatic transmission will not shift up automatically, even when the engine has reached the speed limit for that gear. There is a risk of damaging the engine.

*It is very important to make sure the permissible engine speed is not exceeded.*

| Effect   |   |
|----------|---|
| <b>6</b> | The transmission shifts through sixth gear only (applies to vehicles with 7-speed automatic transmission only). |
| <b>5</b> | The transmission shifts through fifth gear only (applies to vehicles with 7-speed automatic transmission only). |
| <b>4</b> | The transmission shifts through fourth gear only.   |

| Effect   |  |
|----------|--|
| <b>3</b> | The transmission shifts through third gear only.<br><br>With this selection you can use the braking effect of the engine.  |
| <b>2</b> | The transmission shifts through second gear only.<br><br>Allows the use of engine's braking power when driving <ul style="list-style-type: none"> <li>• on steep downgrades</li> <li>• in mountainous regions</li> <li>• under extreme operating conditions</li> </ul> |
| <b>1</b> | The transmission operates in first gear only.<br><br>For maximum use of engine's braking effect on very steep or lengthy downgrades.   |



### Automatic transmission

#### One-touch gearshifting

With the gear selector lever in drive position **D**, you can limit or extend the gear range.

**!** *Allow engine to warm up under low load use. Do not place full load on the engine until the operating temperature has been reached.*

*Shift into reverse gear **R** or park position **P** only when the vehicle is stopped.*

#### Limiting gear range

##### Warning!



On slippery road surfaces, never downshift in order to obtain braking action. This could result in drive wheel slip and reduced vehicle control. Your vehicle's ABS will not prevent this type of loss of control.

- ▶ Briefly press the gear selector lever to the left in the **D-** direction.

The transmission will shift to the next lower gear as permitted by the shift program. This action simultaneously limits the gear range of the transmission (▷ page 167).

**i** *To avoid overrevving the engine when downshifting, the transmission will not shift to a lower gear if the engine's max. speed would be exceeded.*

#### Extending gear range

- ▶ Briefly press the gear selector lever to the right in the **D+** direction.

The transmission will shift to the next higher gear as permitted by the shift program. This action simultaneously extends the gear range of the transmission.

**i** *If you press on the accelerator when the engine has reached its rpm limit, the transmission will upshift beyond any gear range limit selected.*

### Canceling gear range limit

- ▶ Press and hold the gear selector lever in the **D+** direction until **D** reappears in the multifunction display (> page 164).

The transmission will shift from the current gear range directly to gear range **D**.

### Shifting into optimal gear range

- ▶ Press and hold the gear selector lever in the **D-** direction.

The transmission will automatically select the gear range suited for optimal acceleration and deceleration. This will involve shifting down one or more gears.

### Emergency operation (Limp-Home Mode)

---

If vehicle acceleration becomes less responsive or sluggish or the transmission no longer shifts, the transmission is most likely operating in limp-home (emergency operation) mode. In this mode only second gear and reverse gear can be selected.

- ▶ Stop the vehicle in a safe location.
- ▶ Move the gear selector lever to park position **P**.
- ▶ Turn off the engine.
- ▶ Wait at least 10 seconds before restarting.
- ▶ Restart the engine.

- ▶ Move the gear selector lever to position **D** (for second gear) or position **R**.
- ▶ Have the transmission checked at an authorized Mercedes-Benz Light Truck Center as soon as possible.

## Transfer case

For more information on off-road driving, see “Off-road driving” (▷ page 253).

### Transfer case position

|          |  |
|----------|--|
| <b>H</b> | <b>HIGH</b><br>Road position   |
| <b>L</b> | <b>LOW</b><br>Off-road position<br><br>This position is intended for driving off-road and steep gradients.<br><br>The transmission will not upshift automatically to the next higher gear range when driving at the rpm limit.<br><br>The transfer case supports the engine’s driving force (approximately $\frac{1}{2}$ speed).<br>Output is therefore increased. |
| <b>N</b> | <b>Neutral</b><br><br>No power is transmitted from the engine to the drive axle.   |

### Switching transfer case

The transfer case switch is located on the lower part of the center console.



Transfer case switch

The current gear position of the transfer case appears in the multifunction display.



① Transfer case indicator

**Warning!**

Always wait until the procedure of shifting from HIGH to LOW – and from LOW to HIGH – has been entirely completed. During this procedure do not:

- switch off the engine
- shift the automatic transmission into another gear

If you do not wait until the shifting procedure has been entirely completed then it might not be correctly performed. The transfer case might be in neutral, thus interrupting the transfer of power between the engine and the drive axle.

The vehicle is then freely movable, even if a gear has been selected, and could unintentionally be set into motion – particularly on up – or downhill grades. This could lead to an accident and cause injury to yourself and others.

Please observe related messages appearing in the multifunction display (▷ page 172).

**Switching from HIGH to LOW**

**!** *The shift procedure can only be performed when:*

- *the engine is running*
- *the gear selector lever for the automatic transmission is in neutral position **N***
- *the vehicle is not at standstill*
- *the vehicle speed does not exceed 25 mph (40 km/h)*

▶ Press upper half (“LOW”) of the transfer case switch.

Once the shift is complete, gear position **L** appears in the transfer case indicator ① (▷ page 170).

**i** *If the shift procedure does not take place press upper half (“LOW”) of the transfer case switch once more.*

▶ Move the gear selector lever to drive position **D**.

**Switching from LOW to HIGH**

**!** *The shift procedure can only be performed when:*

- *the engine is running*
- *the gear selector lever for the automatic transmission is in neutral position **N***
- *the vehicle is not at standstill*
- *the vehicle speed does not exceed 40 mph (70 km/h)*

▶ Press lower half (“HIGH”) of the transfer case switch.

Once the shift is complete, gear position **H** appears in the transfer case indicator ① (▷ page 170).

**i** *If the shift procedure does not take place press lower half (“HIGH”) of the transfer case switch once more.*

▶ Move the gear selector lever to drive position **D**.

### Transfer case

#### Messages in the multifunction display

If a shift was not completed and one of the following messages appears in the multifunction display:

- TC shift conditions not fulfilled  
The shift did not take place. At least one shift condition was not met.
  - ▶ Repeat the shift procedure.
- TC in neutral  
The shift did not take place. The transfer case is in neutral. Gear position N appears in transfer case indicator ①.
  - ▶ Repeat the shift procedure.

- TC shift procedure canceled  
The shift did not take place.
  - ▶ Repeat the shift procedure.
- **Transfer case Visit workshop**  
There may be a malfunction in the system.
  - ▶ Repeat the shift procedure.
  - ▶ If the shift procedure still does not take place, have the vehicle checked at an authorized Mercedes-Benz Light Truck Center as soon as possible.

**i** If the SmartKey is in starter switch position **0** or **1**, an alarm will sound if the transfer case is in neutral and the driver's door is opened.

Engage the transfer case to gear position **HIGH** or **LOW**.

For more information, see "Practical hints" section (▶ page 363).

#### Warning!



If the transfer case is in neutral, transmission position **P** will not hold vehicle. The parking brake must be applied to hold vehicle in place.

## ▼ Differential locks

For more information on off-road driving, see “Off-road driving” (▷ page 253).

Differential locks improve the vehicle’s tractive power off-road. Switch on differential locks:

- for off-road driving
- to turn the ABS off during off-road driving
- for driving through water
- when driving on deep snow and icy or fouled surfaces

**!** *Do not engage the front axle differential lock when driving around tight corners. This restricts steering ability.*

**!** *When driving off-road, apply only moderate pressure to the accelerator pedal if the differential locks are switched on.*

*When running on a (single-axle) dynamometer – no matter how briefly – you must:*

- *raise the non-driven axle*  
*or*
- *disconnect its drive shaft*  
*and*
- *engage the transfer differential lock*

*Otherwise the transfer case can be damaged, which is not covered by the Mercedes-Benz Limited Warranty.*

### Warning!



Never drive on pavement with differential locks engaged.

Steering control will be strongly affected with the differential locks activated.

The ABS, BAS, and ESP® are switched off automatically when the transfer case differential lock is activated.

### Differential locks

#### A few words about differentials and differential locks

When a vehicle negotiates a turn, wheels on the outside of the curve must travel farther and rotate faster than the inside wheels. The differential, the operation of a set of gears that allows the powered wheels in a vehicle to turn at different speeds, makes this essential function possible.

The drawback is that the differential also sends most of the engine's power to the wheel with the least load or strain on it. For example, if one of a vehicle's powered wheels sits on a patch of snow and spins because there is no traction, all of the engine's power will go to that wheel because the power will take the path of least resistance. Meanwhile, the opposite wheel, sitting on dry pavement where it could get enough grip to start the vehicle moving, sits idle because it receives no power.

The Electronic Traction System (4-ETS) addresses this problem and provides for good control and steering ability by automatically slowing the slipping wheel and thus increasing the power to the other non-slipping drive wheels to get the vehicle moving. The ESP<sup>®</sup> and 4-ETS in this vehicle feature such intelligent limited-slip differential technology, ideally suited for on-road and light off-road driving. Transfer case position **LOW** (▷ page 170) also enhances off-road driving capabilities (▷ page 253).

More extreme off-road conditions may call for another solution, engaging a differential lock or preventing the differential from operating altogether. As part of its standard equipment, this vehicle comes with three differential locks: front, transfer case (center) and rear. Each can be engaged simply by pushing dashboard-mounted switches in sequential order (center, rear, front) (▷ page 175). When the transfer case (center) differential is locked, half of the engine's power is automatically distributed to the front wheels and half to

the rear wheels. When the rear differential is locked, power going to the rear wheels is equally distributed, so that both rear wheels turn at the same speed and torque. When the front differential is locked, all four wheels now turn with equal power and torque. Please be aware that engaging the differential locks will significantly reduce the steering ability of the vehicle.

For your safety and the safety of others and to prevent damage to the vehicle, the differential locks must not be engaged when driving on paved roads. It is important to understand that during on-road/paved driving, differentials are absolutely necessary for providing the essential control and steering ability of the vehicle. The differential locks, therefore, must not be engaged when driving on paved roads and should only be used to the extent necessary to negotiate off-road conditions which cannot be handled by the systems (automatic 4-ETS, the ESP<sup>®</sup>, manual switch position "LOW" of transfer case) this vehicle comes equipped with.

### Switching differential locks on and off

The switches are located on the upper part of the center console.

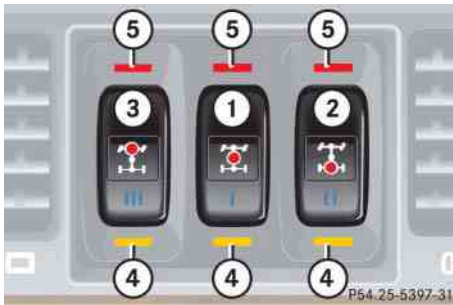

- ① Transfer case (center) differential lock
- ② Rear axle differential lock
- ③ Front differential lock
- ④ Engagement indicator lamps (yellow)
- ⑤ Function indicator lamps (red)

**i** The differential locks can only be switched on in the sequence ①, ②, ③.

### Switching differential locks on

**!** To avoid damage to the transfer case and differential locks:

- Engage differential locks only at low speed (walking speed, not more than 5 mph [8 km/h]).
- Do not engage differential locks if the driving wheels are spinning due to lack of traction.
- Do not engage differential locks on paved roads.

### Transfer case differential lock



- Press switch ①.

The yellow engagement indicator lamp ④ for the transfer case differential lock comes on.

The ESP® warning lamp  comes on.

When the differential lock engagement operation has been completed, the red function indicator lamp ⑤ comes on.

The message ABS not available differential locked appears in the multifunction display.

The ESP® warning lamp  and the  indicator lamp in the instrument cluster come on.

Once the transfer case differential lock is switched on, you can now, if needed,

- switch on rear axle differential lock ②
- or
- switch on rear axle differential lock ② and front differential lock ③.



### Differential locks

#### Rear axle differential lock

- ▶ Press switch ②.

The yellow engagement indicator lamp ④ comes on first, followed by the red function indicator lamp ⑤.

The rear axle differential lock is switched on.

#### Front differential lock

- ▶ Press switch ③.

The yellow engagement indicator lamp ④ comes on first, followed by the red function indicator lamp ⑤.

The front differential lock is switched on.



#### Switching differential locks off

There are two different methods to disengage differential locks:

- You can switch the differential locks off in reverse order (③, ②, ①).
- To switch off all differential locks at the same time:
  - ▶ Press switch ①.

The yellow engagement indicator lamps ④ go out first. The red function indicator lamps ⑤ go out when the switching process has been carried out in the differential.

To activate the ESP®, BAS, and ABS systems, drive again for 3 seconds using a constant driving style.

All messages in the multifunction display disappear. The ESP® warning lamp  and the  indicator lamp in the instrument cluster go out.

 *If the red function indicator lamps ⑤ do not go out when the differential locks are disengaged, bring vehicle to a stop and then continue driving. Changing the vehicle load can help to disengage locks.*

#### Warning!



Always remember to disengage the differential locks when returning to drive on paved roads, see “A few words about differentials and differential locks” (▷ page 174).

## ▼ Good visibility

For information on windshield wipers, see “Windshield wipers” (▷ page 58).

### Headlamp cleaning system

The button is located on the dashboard to the left of the steering wheel.



#### ① Headlamp cleaning button

- ▶ Switch on the ignition (▷ page 39).
- ▶ Press button ①.

The headlamps are cleaned with a high-pressure water jet.

**i** *The headlamps will automatically be cleaned when you have*

- *switched on the headlamps*  
*and*
- *operated the windshield wipers with windshield washer fluid fifteen times*

*When you switch off the ignition, the counter resets.*

For information on filling up the washer reservoir, see “Windshield/rear window washer system and headlamp cleaning system” (▷ page 275).

### Rear view mirrors

For more information on setting the rear view mirrors, see “Mirrors” (▷ page 46).

### Auto-dimming rear view mirrors

The reflection brightness of the exterior rear view mirrors and the interior rear view mirror will respond automatically to glare when

- the ignition is switched on  
and
- incoming light from headlamps falls on the sensor in the interior rear view mirror

The exterior rear view mirrors and the interior rear view mirror will not react if

- reverse gear **R** is engaged
- the interior lighting is turned on

### Warning!



The auto-dimming function does not react if incoming light is not aimed directly at sensors in the interior rear view mirror.

The interior rear view mirror and the exterior rear view mirrors do not react, for example, when transporting cargo which covers the rear window.

Light hitting the mirror(s) at certain angles (incident light) could blind you. As a result, you may not be able to observe traffic conditions and could cause an accident.

### Good visibility

#### Warning!



Exercise care when using the passenger-side exterior rear view mirror. The mirror surface is convex (outwardly curved surface for a wider field of view). Objects in mirror are closer than they appear. Check your interior rear view mirror or glance over your shoulder before changing lanes.

#### Activating exterior rear view mirror parking position

Follow these steps to activate the mirror parking position so that the passenger-side exterior rear view mirror will be turned downward to the stored position.

The exterior rear view mirror buttons are located above the exterior lamp switch.

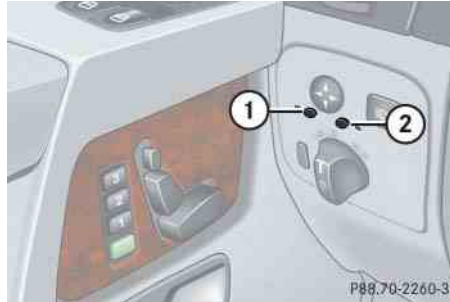

- ① Driver's side exterior rear view mirror button
  - ② Passenger-side exterior rear view mirror button
- ▶ Switch on the ignition (▷ page 39).
  - ▶ Make sure you have stored a parking position for the passenger-side exterior rear view mirror (▷ page 116).
  - ▶ Press button ②.

The passenger-side exterior rear view mirror is selected.

- ▶ Move the gear selector lever to reverse gear **R**.

The passenger-side exterior rear view mirror will be turned downward to the stored position.

The exterior rear view mirror returns to its previously stored driving position:

- 10 seconds after moving the gear selector lever out of position **R**
- immediately once you exceed a vehicle speed of approximately 6 mph (10 km/h)
- immediately when you press button ① for driver's side exterior rear view mirror

### Sun visors

The sun visors protect you from sun glare while driving.

#### Warning!



Do not use the vanity mirror while driving. Keep the mirrors in the sun visors closed while vehicle is in motion. Reflected glare can endanger you and others.

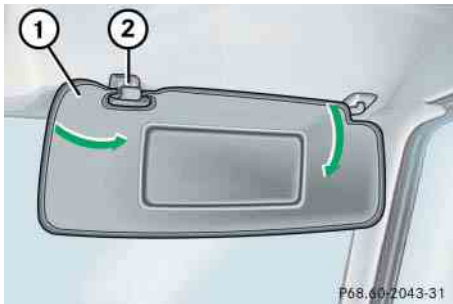

- ① Sun visor
- ② Mounting

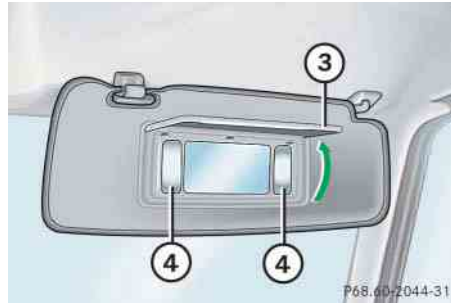

- ③ Vanity mirror cover
- ④ Vanity mirror lamps

### Glare through the windshield

- ▶ Swing sun visor ① down.
- ▶ When you do not experience glare anymore, swing sun visor ① up.

### Vanity mirror

**i** Make sure the ignition is switched on (▷ page 39) and sun visor ① is properly engaged in mounting ②.

- ▶ Swing sun visor ① down.
- ▶ Flip up vanity mirror cover ③ to access vanity mirror.

Vanity mirror lamps ④ come on.

- ▶ After using vanity mirror, flip down vanity mirror cover ③.
- ▶ Swing sun visor ① up.

### Good visibility

#### Glare to a side window

- ▶ Swing sun visor ① down.
- ▶ Disengage sun visor ① from mounting ②.

**!** To avoid damage to vanity mirror cover ③, make sure it is closed before pivoting sun visor ① to the side.

- ▶ Pivot sun visor ① to the side.
- ▶ When you do not experience glare anymore, pivot sun visor ① to the windshield.
- ▶ Engage sun visor ① into mounting ②.
- ▶ Swing sun visor ① up.

#### Windshield defroster

The windshield defroster uses a large amount of power. To keep battery drain to a minimum, switch off the windshield defroster as soon as the windshield is clear.

The windshield defroster switches off automatically after 10 minutes.

If you switch on the windshield defroster for the fourth time in succession, it will switch off automatically after 5 minutes.

You cannot switch on the windshield defroster if the outside temperature is above 10°C (50°F).

#### Warning!



Any accumulation of snow and ice should be removed from the windshield before driving. Visibility could otherwise be impaired, endangering you and others.

The windshield defroster switch is located on the upper part of the center console.



- ① Windshield defroster switch
- ② Indicator lamp

Switch on the ignition (▷ page 39).

### Activating

- ▶ Press switch ①.
- Indicator lamp ② comes on.

### Deactivating

- ▶ Press switch ① once more.
- Indicator lamp ② goes out.

**!** *If too many electrical consumers are operating simultaneously and there is insufficient voltage in the battery, indicator lamp ② in windshield defroster switch ① starts flashing. After approximately 30 seconds the system responds automatically by switching the windshield defroster off.*

### Rear window defroster

The rear window defroster uses a large amount of power. To keep battery drain to a minimum, switch off the rear window defroster as soon as the rear window is clear.

The rear window defroster switches off automatically after approximately 6 to 17 minutes of operation depending on the outside temperature.



#### Warning!



Any accumulation of snow and ice should be removed from the rear window before driving. Visibility could otherwise be impaired, endangering you and others.

Switch on the ignition (▷ page 39).

### Activating



- ▶ Press button  or  on the respective climate control panel (▷ page 183).

The indicator lamp on the button comes on.

### Deactivating

- ▶ Press button  or  once more.

The indicator lamp on the button goes out.

**!** *If the rear window defroster switches off too soon and the indicator lamp in button  or  starts flashing, too many electrical consumers are operating simultaneously and there is insufficient voltage in the battery. The system responds automatically by switching the rear window defroster off.*

*As soon as the battery has sufficient voltage, the rear window defroster switches back on automatically.*

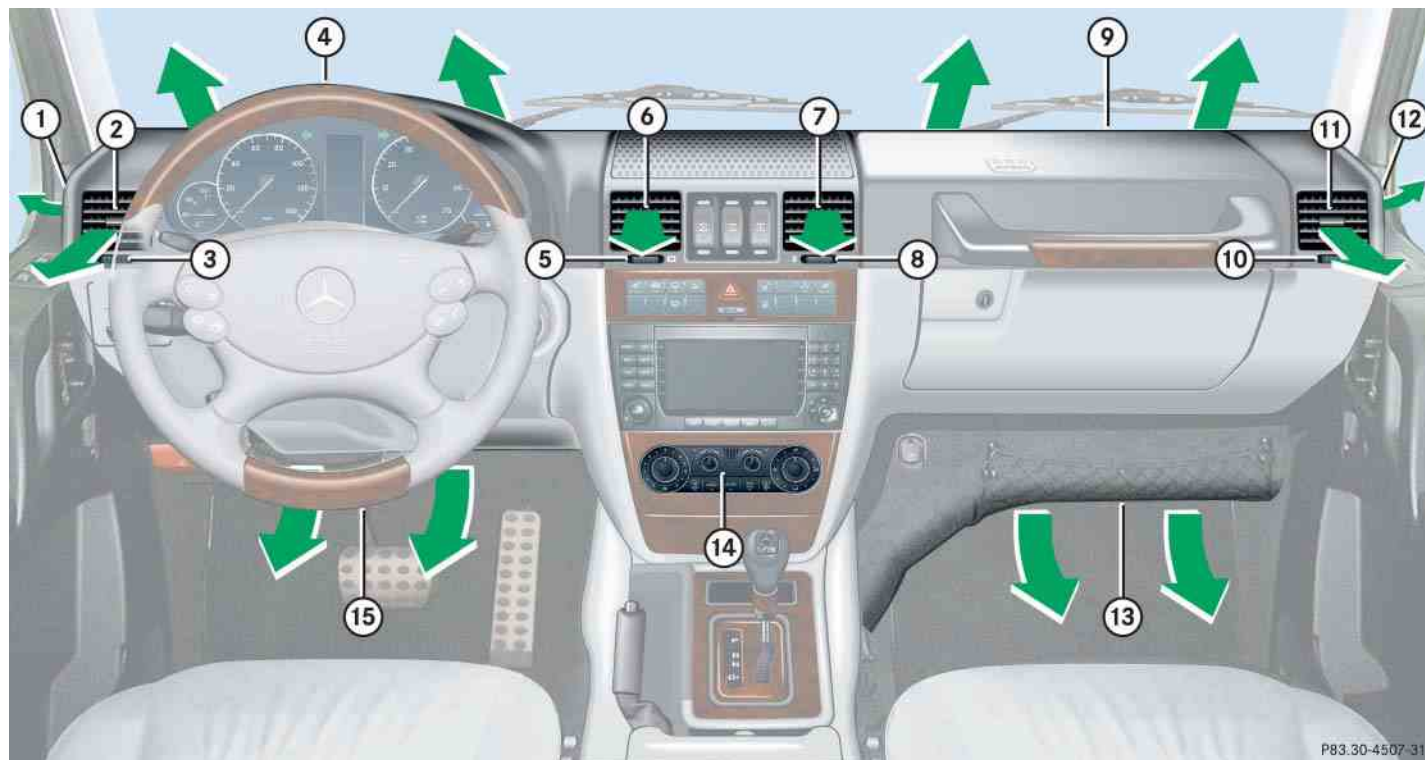

| Item  |
|---|
| ① Left side defroster air vent, fixed                         |
| ② Left side air vent, adjustable                              |
| ③ Thumbwheel for air volume control for left side air vent    |
| ④ Left front defroster air vent                               |
| ⑤ Thumbwheel for air volume control for left center air vent  |
| ⑥ Left center air vent, adjustable                            |
| ⑦ Right center air vent, adjustable                           |
| ⑧ Thumbwheel for air volume control for right center air vent |
| ⑨ Right front defroster air vent                              |
| ⑩ Thumbwheel for air volume control for right side air vent   |
| ⑪ Right side air vent, adjustable                             |
| ⑫ Right side defroster air vent, fixed                        |
| ⑬ Right footwell air vent                                     |
| ⑭ Climate control panel                                       |
| ⑮ Left footwell air vent                                      |

**i** For draft-free ventilation, move the sliders for the center air vents and side air vents to the middle position.

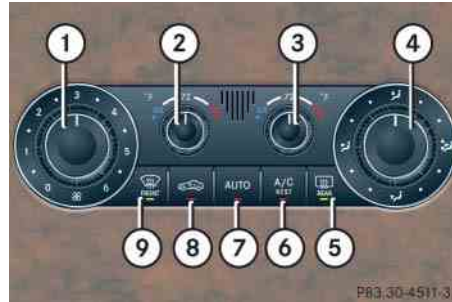

**Climate control panel (U.S. vehicles)**



**Climate control panel (Canada vehicles)**

| Item  |
|---|
| ① Air volume control                                  |
| ② Left side temperature control                       |
| ③ Right side temperature control                      |
| ④ Air distribution control                            |
| ⑤ Rear window defroster (▷ page 181)                  |
| ⑥ AC cooling on/off<br>Residual heat/ventilation      |
| ⑦ Air distribution and air volume<br>(automatic mode) |
| ⑧ Air recirculation                                   |
| ⑨ Front defroster                                     |



### Climate control

The climate control is operational whenever the engine is running. You can operate the climate control system in either the automatic or manual mode. The system cools or heats the interior depending on the selected interior temperature and the current outside temperature.

#### Warning!



When operating the climate control, the air that enters the passenger compartment through the air vents can be very hot or very cold (depending on the set temperature). This may cause burns or frostbite on unprotected skin in the immediate area of the air vents. Always keep sufficient distance between unprotected parts of the body and the air vents. If necessary, use the air distribution control (▷ page 186) to direct the air to air vents in the vehicle interior that are not in the immediate area of unprotected skin.

Nearly all dust particles, pollutants and odors are filtered out before outside air enters the passenger compartment through the air distribution system.

The air conditioning will not engage (no cooling) if the **A/C** mode is deactivated (▷ page 189).

#### Warning!



Follow the recommended settings for heating and cooling given on the following pages. Otherwise the windows could fog up, impairing visibility and endangering you and others.

**i** Severe conditions (e.g. strong air pollution) may require replacement of the filter before its scheduled interval. A clogged filter will reduce the air volume to the interior.

*If the vehicle interior is hot, ventilate the interior before driving off, see “Summer opening feature” (▷ page 193). The climate control will then adjust the interior temperature to the set value much faster.*

*Keep the air intake grille in front of the windshield free of snow and debris.*

## Deactivating the climate control system

### Warning!



When the climate control is switched off, the outside air supply and circulation are also switched off. Only choose this setting for a short time. Otherwise the windows could fog up, impairing visibility and endangering you and others.

### Deactivating

- ▶ Set air volume control ① (▷ page 183) to position **0**.

### Reactivating

- ▶ Make sure the ignition is switched on (▷ page 39).
- ▶ Set air volume control ① (▷ page 183) to any speed.

The previous settings are once again in effect.

## Operating the climate control system in automatic mode

**i** When operating the climate control system in automatic mode, you will only rarely need to adjust the temperature, air volume and air distribution.

*In automatic mode, cooling with dehumidify is switched on. This function can be switched off by pressing button  if necessary (▷ page 189).*

### Activating

- ▶ Press button **AUTO** (▷ page 183) while the engine is running.  
The indicator lamp on the button comes on. The air volume and air distribution are adjusted automatically.
- ▶ Use temperature controls ② and ③ (▷ page 183) to separately adjust the air temperature on each side of the passenger compartment.  
The interior air temperature is adjusted automatically.

## Deactivating

- ▶ Press button **AUTO** (▷ page 183) once more.

The indicator lamp on the button goes out. The automatic operation of the air volume and air distribution switches off.

## Setting the temperature

Use temperature controls ② and ③ (▷ page 183) to separately adjust the air temperature on each side of the passenger compartment. You should raise or lower the temperature setting in small increments, preferably starting at 72°F (22°C). The climate control will adjust to the set temperature as fast as possible.

### Climate control

#### Increasing

- ▶ Turn temperature control ② and/or ③ (▷ page 183) slightly clockwise.

The climate control system will correspondingly adjust the interior air temperature.

**i** If you turn the temperature control fully clockwise for one side of the vehicle, you are increasing the temperature for the other side of the vehicle as well.

#### Decreasing





- ▶ Turn temperature control ② and/or ③ (▷ page 183) slightly counterclockwise.

The climate control system will correspondingly adjust the interior air temperature.

**i** If you turn the temperature control fully counterclockwise for one side of the vehicle, you are decreasing the temperature for the other side of the vehicle as well.

#### Adjusting air distribution

Use air distribution control ④ (▷ page 183) to adjust the air distribution. The following symbols are found on the controls:

| Symbol  | Function   |
|---|--|
|  | Directs air through the center, side, and rear passenger compartment air vents |
|  | Directs air to the windshield and the side defroster air vents                 |
|  | Directs air into the entire vehicle interior                                   |
|  | Directs air to the footwells   |

- ▶ Press button **AUTO** (▷ page 183).

The indicator lamp on the button goes out. The automatic air distribution control is switched off. The air distribution is adjusted according to the currently selected setting.

- ▶ Turn air distribution control ④ (▷ page 183) to the desired symbol.

#### Adjusting air volume

Six blower speeds are available.

- ▶ Press button **AUTO** (▷ page 183).

The indicator lamp on the button goes out. The automatic air volume control is switched off. The air volume is adjusted according to the currently selected setting.

- ▶ Turn air volume control ① (▷ page 183) to the desired blower speed.

### Adjusting air volume for the center air vents

#### Opening the center air vents

- ▶ Turn thumbwheel ⑤ and/or ⑧ (▷ page 182) to the right.  
Center air vent ⑥ and/or ⑦ (▷ page 182) is open.

#### Closing the center air vents

- ▶ Turn thumbwheel ⑤ and/or ⑧ (▷ page 182) to the left.  
Center air vent ⑥ and/or ⑦ (▷ page 182) is closed.

### Adjusting air volume for the side air vents

#### Opening the side air vents

- ▶ Turn thumbwheel ③ and/or ⑩ (▷ page 182) to the right.  
Side air vent ② and/or ⑪ (▷ page 182) is open.

### Closing the side air vents



- ▶ Turn thumbwheel ③ and/or ⑩ (▷ page 182) to the left.  
Side air vent ② and/or ⑪ (▷ page 182) is closed.

### Front defroster

You can use this setting to defrost the windshield, for example if it is iced up. You can also defog the windshield and the side windows.

**i** *Keep this setting selected only until the windshield or the side windows are clear again.*

### Activating

- ▶ Press button  or  (▷ page 183).

The indicator lamp on the button comes on.



The climate control switches to the following functions automatically:

- maximum blower speed and heating power
- air flows onto the windshield and the front side windows (side air vents must be open)
- the air recirculation mode is switched off

**i** *If you have switched on the defrost function using button  or , you cannot make any other settings.*

### Climate control

#### Deactivating

- ▶ Press button  or  (▷ page 183) once more.

The indicator lamp on the button goes out. Defrosting is switched off.

**i** *The cooling remains switched on.*

#### Windshield fogged on the outside

**i** *Keep this setting selected only until the windshield is clear again.*

- ▶ Switch the windshield wipers on (▷ page 58).

If the automatic mode of the climate control is switched off:



- ▶ Turn air distribution control ④ to  or  (▷ page 183).

#### Air recirculation mode

Switch to air recirculation mode to prevent unpleasant odors from entering the vehicle from the outside (e.g. before driving through a tunnel). This setting cuts off the intake of outside air and recirculates the air in the passenger compartment.

#### Warning!



Fogged windows impair visibility, endangering you and others. If the windows begin to fog on the inside, switching off the air recirculation mode immediately should clear interior window fogging. If interior window fogging persists, make sure the air conditioning (▷ page 189) is activated, or press button  or .

#### Activating

- ▶ Press button  (▷ page 183).

The indicator lamp on the button comes on.

**i** *The air recirculation mode is activated automatically at high outside temperatures.*

*The indicator lamp on button  is not lit when the air recirculation mode is switched on automatically.*

*A quantity of outside air is added after approximately 30 minutes.*

*If you have turned off the air conditioning (▷ page 189) or the outside temperature is below 41 °F (5 °C), the air recirculation mode will not switch on automatically.*

## Deactivating

- ▶ Press button  (> page 183) once more.

The indicator lamp on the button goes out.

 *The air recirculation mode is deactivated automatically:*

- after 5 minutes if the outside temperature is below approximately 41 °F (5 °C)
- after 5 minutes if the air conditioning is turned off
- after 30 minutes if the outside temperature is above approximately 41 °F (5 °C)

## Air conditioning

The cooling function, only operational when the engine is running, cools the vehicle interior down to the selected temperature. The cooling function also dehumidifies the air in the vehicle interior, thus preventing the windows from fogging up.

 *Condensation may drip out from underneath the vehicle. This is normal and not an indication of a malfunction.*

### Warning!



If you turn off the cooling function, the interior air is not dried. The windows can fog up more quickly. Window fogging may impair visibility and endanger you and others.

## Deactivating

It is possible to deactivate the air conditioning (cooling) function of the climate control system. The air in the vehicle will then no longer be cooled or dehumidified.

- ▶ Press button  (> page 183).

The indicator lamp on the button goes out.

The cooling function switches off after a short delay.

### Climate control

#### Activating

Moist air can fog up the windows. You can dehumidify the air with the air conditioning.

- ▶ Press button  (▷ page 183) once more.

The indicator lamp on the button comes on.

The air conditioning uses the refrigerant R134a. This refrigerant is free of CFCs which are harmful to the ozone layer.

**!** *If the air conditioning cannot be turned on again, this indicates that the air conditioning is losing refrigerant. The compressor has turned itself off.*

*Have the air conditioning checked at the nearest authorized Mercedes-Benz Light Truck Center.*

#### Residual heat and ventilation

With the engine switched off, it is possible to continue to heat or ventilate the interior for up to 30 minutes. This feature makes use of the residual heat produced by the engine.

**i** *How long the system will provide heating depends on*

- *the coolant temperature*
- *the battery voltage*

*Regardless of the temperature and air volume set on the climate control panel, an interior temperature is aimed at by 72°F (22°C) and the blower runs on low speed to protect the vehicle battery.*

#### Activating

- ▶ Turn the SmartKey in the starter switch to position **0** or **1** (▷ page 39).

or

- ▶ Remove the SmartKey from the starter switch.
- ▶ Press button  (▷ page 183).

The indicator lamp on the button comes on.

#### Deactivating

- ▶ Press button  (▷ page 183) once more.

The indicator lamp on the button goes out.

**i** *The residual heat is automatically turned off:*

- *when the ignition is switched on*
- *after about 30 minutes*
- *if the coolant temperature is too low*
- *if the battery voltage drops*

### Rear passenger compartment adjustable air vents

The air conditioning for the rear passenger compartment is controlled via the climate control panel (> page 183).

The air vents for the rear passenger compartment are located in the rear center console.

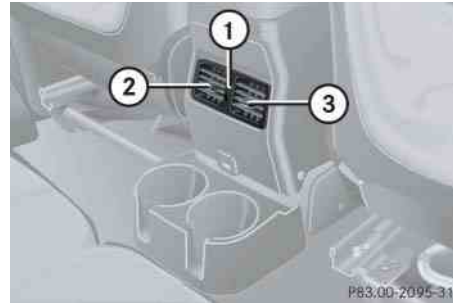

- ① Thumbwheel for air volume control for center air vents
- ② Left center air vent, adjustable
- ③ Right center air vent, adjustable

**i** *The temperature at the center air vents ② and ③ for the rear passenger compartment is the same as at the dashboard center air vents.*

### Adjusting air distribution

- ▶ Push the slide for the left center vent ② or right center air vent ③ to the left, right, up, or down.

The air flow is directed in the corresponding direction.

**i** *For draft-free ventilation, move the sliders for the center air vents ② and ③ upward.*

### Adjusting air volume

- ▶ Turn thumbwheel ① up.  
The air volume is increased.
- ▶ Turn thumbwheel ① down.  
The air volume is decreased.



### Power windows

#### Opening and closing

The side windows are opened and closed electrically. The switches for all side windows are located on the driver's door control panel. The switches for the respective side windows are located on the front passenger door and the rear doors.

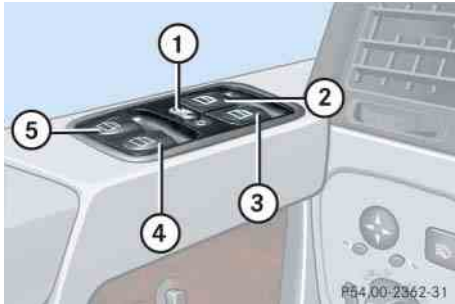

- ① Override switch (▷ page 86)
- ② Left front window
- ③ Right front window
- ④ Right rear window
- ⑤ Left rear window

#### Warning!



When closing the windows, make sure there is no danger of anyone being harmed by the closing procedure.

Activate the override switch (▷ page 86) when children are riding in the back seats of the vehicle. The children could otherwise injure themselves, e.g. by becoming trapped in the window opening.

The closing procedure can be immediately halted by releasing the switch or by releasing button  on the SmartKey.

When leaving the vehicle, always remove the SmartKey from starter switch, take it with you, and lock the vehicle. Do not leave children unattended in the vehicle, or with access to an unlocked vehicle. Unsupervised use of vehicle equipment can cause an accident and/or serious personal injury.

**i** You can also open or close the windows using the SmartKey, see “Summer opening feature” (▷ page 193) and see “Convenience closing feature” (▷ page 194).

- ▶ Switch on the ignition (▷ page 39).

#### Opening the windows

- ▶ Press switch ②, ③, ④ or ⑤ to the resistance point.

The corresponding window will move downwards until you release the switch.

#### Closing the windows

- ▶ Pull switch ②, ③, ④ or ⑤ to the resistance point.

The corresponding window will move upwards until you release the switch.

### Fully opening the windows (Express-open)

- ▶ Press switch ②, ③, ④ or ⑤ past the resistance point and release.

The corresponding window opens completely.

### Stopping the windows during Express-operation

- ▶ Press or pull the respective switch again.

The movement of the window stops.

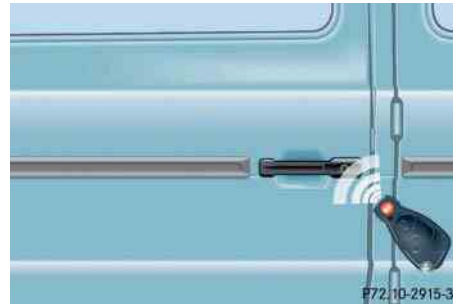

### Summer opening feature

If the weather is warm, you can ventilate the vehicle before driving off by simultaneously opening the windows and the tilt/sliding sunroof.



- ▶ Aim transmitter eye of the SmartKey at the driver's outside door handle.

The SmartKey must be in close proximity to the driver's outside door handle.

- ▶ Press and hold button  on the SmartKey until the windows and the tilt/sliding sunroof have reached the desired position.
- ▶ Release button  on the SmartKey to interrupt the opening procedure.

### Power windows

#### Convenience closing feature



When locking the vehicle, you can close the windows and the tilt/sliding sunroof simultaneously.

#### Warning!





When closing the windows and the tilt/sliding sunroof, make sure that there is no danger of anyone being harmed by the closing procedure.

If potential danger exists, proceed as follows:

- Release button  to stop the closing procedure. To open, press and hold button . To continue the closing procedure after making sure that there is no danger of anyone being harmed by the closing procedure, press and hold button .

- ▶ Aim transmitter eye of the SmartKey at the driver's outside door handle (▷ page 193).

The SmartKey must be in close proximity to the driver's outside door handle.

- ▶ Press and hold button  on the SmartKey until the windows and the tilt/sliding sunroof are completely closed.
- ▶ Release button  on the SmartKey to interrupt the closing procedure.

## ▼ Power tilt/sliding sunroof

### Opening and closing

The tilt/sliding sunroof is opened and closed electrically. The switch for the tilt/sliding sunroof is located on the overhead control panel.

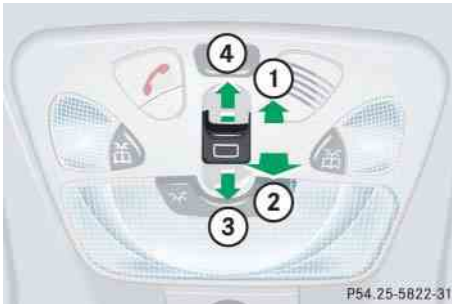

#### Sunroof switch

- ① Push up to raise sunroof at rear
- ② Pull down to lower sunroof at rear
- ③ Push forward to slide sunroof closed
- ④ Push back to slide sunroof open

### Warning!



When closing the tilt/sliding sunroof, make sure there is no danger of anyone being harmed by the closing procedure.

The opening procedure of the tilt/sliding sunroof can be immediately halted by releasing the switch or, if the switch was moved past the resistance point and released, by moving the switch in any direction.

The closing procedure of the tilt/sliding sunroof can be immediately halted by releasing the switch.

The closing procedure of the tilt/sliding sunroof can be immediately reversed by moving the switch in direction ① or ④.

In a vehicle rollover, occupants not wearing their seat belts or not wearing them properly may be thrown out of the opening. Such an opening also presents a potential for injury for occupants wearing their seat belts properly as entire body parts or portions of them may protrude from the passenger compartment.

When leaving the vehicle, always remove the SmartKey from the starter switch, take it with you, and lock the vehicle. Do not leave children unattended in the vehicle, or with access to an unlocked vehicle. Unsupervised use of vehicle equipment can cause an accident and/or serious personal injury.

**!** To avoid damaging the seals, do not transport any objects with sharp edges which can stick out of the tilt/sliding sunroof.

Do not open the tilt/sliding sunroof if there is snow or ice on the roof, as this could result in malfunctions.

The tilt/sliding sunroof can be opened or closed manually should an electrical malfunction occur (▷ page 374).

### Power tilt/sliding sunroof

**!** Please keep in mind that weather conditions can sometime change rapidly. Make sure to close the tilt/sliding sunroof when leaving the vehicle. If water enters the vehicle interior, vehicle electronics could be damaged which is not covered by the Mercedes-Benz Limited Warranty.

**i** When the tilt/sliding sunroof is open, resonance noises may result in addition to the usual wind noises. They are caused by minimal pressure changes in the passenger compartment. To reduce or eliminate these noises, change the position of the tilt/sliding sunroof or open a side window slightly.

**i** You can also open or close the tilt/sliding sunroof using the SmartKey, see “Summer opening feature” (▷ page 193) and see “Convenience closing feature” (▷ page 194).

- ▶ Switch on the ignition (▷ page 39).

#### Opening and closing the tilt/sliding sunroof

- ▶ To open, close, raise, or lower the tilt/sliding sunroof, move the sunroof switch to the resistance point in the required direction of arrows ① to ④ (▷ page 195).
- ▶ Release the sunroof switch when the tilt/sliding sunroof has reached the desired position.

#### Fully opening the tilt/sliding sunroof (Express-open)

- ▶ Move the sunroof switch past the resistance point in direction of arrow ④ (▷ page 195) and release.

The tilt/sliding sunroof opens completely.

#### Stopping the tilt/sliding sunroof during Express-operation

- ▶ Move the sunroof switch in any direction.  
The movement of the tilt/sliding sunroof stops.

#### Warning!



The opening procedure of the tilt/sliding sunroof can be immediately halted by releasing the switch or, if the switch was moved past the resistance point and released, by moving the switch in any direction.

The closing procedure of the tilt/sliding sunroof can be immediately halted by releasing the switch.

The closing procedure of the tilt/sliding sunroof can be immediately reversed by moving the switch in direction ① or ④.

## ▼ Driving systems

The driving systems of your vehicle are described on the following pages:

- Cruise control (▷ page 197), with which the vehicle can maintain a preset speed.
- Rear Parking Assist (▷ page 200) and rear view camera (▷ page 203), which serve as parking aid.

For information on the ABS, BAS, ESP®, 4-ETS, and EBB driving systems, see “Driving safety systems” (▷ page 88).

### Cruise control

The cruise control automatically maintains the speed you set for your vehicle.

The use of the cruise control is recommended for driving at a constant speed for extended periods of time. You can set or resume the cruise control at any speed over 20 mph (30 km/h).

The cruise control function is operated by means of the cruise control lever.

The cruise control lever is the uppermost lever found on the left-hand side of the steering column (▷ page 24).

 *The cruise control should not be activated during-off road driving.*

### Warning!



The cruise control is a convenience system designed to assist the driver during vehicle operation. The driver is and must always remain responsible for the vehicle's speed and for safe brake operation.

Only use the cruise control if the road, traffic and weather conditions make it advisable to travel at a steady speed.

- The use of the cruise control can be dangerous on winding roads or in heavy traffic because conditions do not allow safe driving at a steady speed.
- The use of the cruise control can be dangerous on slippery roads. Rapid changes in tire traction can result in wheel spin and loss of control.
- Deactivate the cruise control when driving in fog.

The “Resume” function should only be operated if the driver is fully aware of the previously set speed and wishes to resume this particular preset speed.

## Driving systems

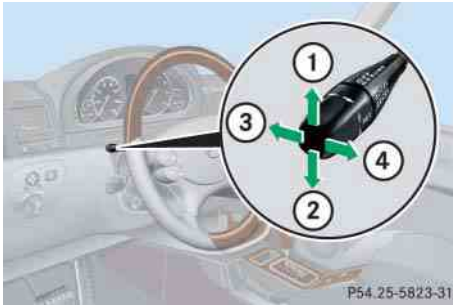

- ① Setting current or higher speed
- ② Setting current or lower speed
- ③ Canceling cruise control
- ④ Resuming to last speed set

### Setting current speed

- ▶ Accelerate or decelerate to the desired speed.
- ▶ Briefly lift the cruise control lever in direction of arrow ① or depress in direction of arrow ②.

The current speed is set.

- ▶ Remove your foot from the accelerator pedal.

The cruise control is activated.

- i** On uphill or downhill grades, the cruise control may not be able to maintain the set speed. Once the grade eases, the set speed will be resumed.

### Canceling cruise control

There are several ways to cancel cruise control:

- ▶ Step on the brake pedal.

The cruise control is canceled. The last speed set is stored for later use.

or

- ▶ Briefly push the cruise control lever in direction of arrow ③.

The cruise control is canceled. The last speed set is stored for later use.

**!** Moving the gear selector lever to neutral position **N** while driving also cancels the cruise control. However, the gear selector lever should not be moved to neutral position **N** while driving, except to coast when the vehicle is in danger of skidding (e.g. on icy roads).

- i** The last stored speed is canceled when you turn off the engine.

### Setting a higher speed

#### Warning!



If you increase the vehicle set speed, keep in mind that it may take a brief moment until the vehicle has reached the set speed.

Increase the vehicle set speed to a value that the prevailing road conditions and legal speed limits permit. Otherwise, sudden and unexpected acceleration of the vehicle could cause an accident and/or serious injury to you and others.

- ▶ Lift the cruise control lever in direction of arrow ① and hold it up until the desired speed is reached.
- ▶ Release the cruise control lever.

The new speed is set.

**i** *Depressing the accelerator pedal does not deactivate the cruise control. After brief acceleration (e.g. for passing), the cruise control will resume the last speed set.*

### Setting a lower speed

- ▶ Depress the cruise control lever in direction of arrow ② and hold it down until the desired speed is reached.
- ▶ Release the cruise control lever.

The new speed is set.

**i** *When you use the cruise control lever to decelerate, the transmission will automatically downshift if the engine's braking power does not brake the vehicle sufficiently.*

### Fine adjustment in 1 mph (Canada: 1 km/h) increments

#### **Faster**

- ▶ Briefly lift the cruise control lever in direction of arrow ①.

#### **Slower**

- ▶ Briefly depress the cruise control lever in direction of arrow ②.

### Setting to last stored speed ("Resume" function)

#### **Warning!**



The speed stored in memory should only be set again if prevailing road conditions permit. Possible acceleration or deceleration differences arising from returning to the preset speed could cause an accident and/or serious injury to you and others.

- ▶ Briefly pull the cruise control lever in direction of arrow ④.
- The cruise control resumes to the last speed set.
- ▶ Remove your foot from the accelerator pedal.



#### Rear Parking Assist

##### Warning!



Rear Parking Assist (rear Parktronic) is a supplemental system. It is not intended to, nor does it replace, the need for extreme care. The responsibility during parking and other critical maneuvers always remains with the driver.

Special attention must be paid to objects with smooth surfaces or low silhouettes (e.g. trailer couplings, painted posts, or road curbs). Such objects may not be detected by the system and can damage the vehicle.

The operational function of the Rear Parking Assist can be affected by dirty sensors, especially at times of snow and ice. See “Cleaning the Rear Parking Assist sensors” (▷ page 318).

Interference caused by other ultrasonic signals (e.g. working jackhammers, car wash, or the air brakes of trucks) can cause the system to send erratic indications, and should be taken into consideration.

##### Warning!



Make sure no persons or animals are in the area in which you are maneuvering. You could otherwise injure them.

The Rear Parking Assist system is an electronic aid designed to assist the driver during parking maneuvers. It visually and audibly indicates the relative distance between the rear of the vehicle and an obstacle.

The Rear Parking Assist system is automatically activated when you

- switch on the ignition
- and
- move the gear selector lever to reverse gear **R**

The Rear Parking Assist system monitors the rear surrounding of your vehicle with four sensors in the rear bumper.

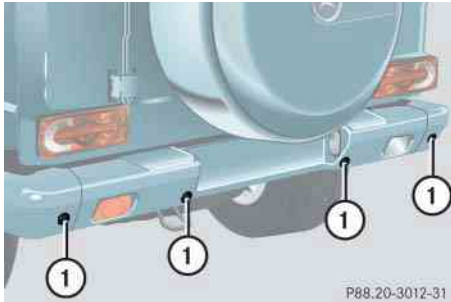

P88.20-3012-31

① Sensors

### Range of the sensors

To function properly, the sensors must be free of dirt, ice, snow, and slush. Clean the sensors regularly, being careful not to scratch or damage the sensors, see “Cleaning the Rear Parking Assist sensors” (▷ page 318).

**!** During parking maneuvers, pay special attention to objects located above or below the height of the sensors (e.g. planters or trailer hitches). The Rear Parking Assist system will not detect such objects at close range and damage to your vehicle or the object may result.

Ultrasonic signals from outside sources (e.g. working jackhammers, car wash, or the air brakes of trucks) may impair the operation of the Rear Parking Assist system.

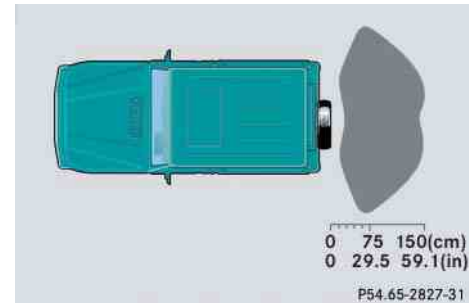
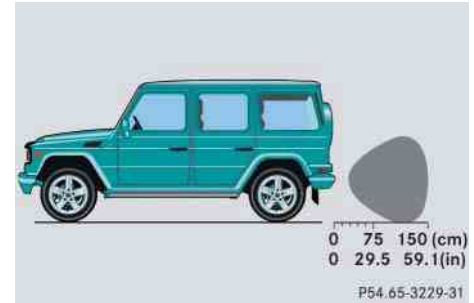

## Driving systems

### Sensors

|         |                                 |
|---------|---------------------------------|
| Center  | <b>approx. 59.1 in (150 cm)</b> |
| Corners | <b>approx. 40 in (100 cm)</b>   |

### Minimum distance

|         |                               |
|---------|-------------------------------|
| Center  | <b>approx. 7.9 in (20 cm)</b> |
| Corners | <b>approx. 7.9 in (20 cm)</b> |

If the system detects an obstacle in this range, all the distance segments in the warning indicator (▷ page 202) illuminate and you hear a warning signal. If the obstacle is closer than the minimum distance, the actual distance may no longer be indicated by the system.

### Warning indicator

Visual signals indicate to the driver the relative distance between the sensors and an obstacle.

The warning indicator is located next to the tailgate.



### Warning indicator

- ① Distance segments
- ② Readiness indicator

The warning indicator is divided into four yellow, and two red distance segments ①. The Rear Parking Assist system is ready when you hear a signal and the readiness indicator ② is illuminated.

As your vehicle approaches an object, one or more distance segments will illuminate, depending on the distance. When the sixth distance segment illuminates, you have reached the minimum distance.

An intermittent acoustic warning will sound when the fourth yellow distance segment illuminates. This signal quickens with each additional distance segment illuminated. When all distance segments illuminate, the acoustic warning becomes a constant signal. The signal is canceled when the gear selector lever is moved to drive position **D** or park position **P**.

## Rear Parking Assist system malfunction

If no distance segments illuminate and no acoustic warning sounds, there is a malfunction in the Rear Parking Assist system.

- ▶ Have the Rear Parking Assist system checked at an authorized Mercedes-Benz Light Truck Center as soon as possible.

## Rear view camera

### Warning!



The rear view camera is only an aid and may display obstacles from a distorted perspective or inaccurately, or may not display obstacles at all. The rear view camera does not relieve you of the responsibility to be cautious, take care and pay careful attention.

The rear view camera may not show objects which are

- very close to the rear bumper
- under the rear bumper
- under the spare wheel
- nearby behind the spare wheel

You are responsible for safety at all times and must continue to pay attention to the immediate surroundings when parking and maneuvering. This includes the area behind, in front of and beside the vehicle. Otherwise you could endanger yourself or others.

### Warning!



Make sure that no persons or animals are in or near the area in which you are parking/maneuvering. Otherwise, they could be injured.

### Warning!



The rear view camera either will not function or will not function to its full capability if

- the tailgate is open
- it is raining very hard, snowing or foggy
- it is night or you are parking/maneuvering your vehicle in an area where it is very dark
- the camera is exposed to a very bright white light
- the immediate surroundings are illuminated with fluorescent light (the display may flicker)



### Driving systems



- there is a sudden change in temperature, e.g. if you drive into a heated garage from the cold (lens condensation)
  - the camera lens is dirty or covered
  - the rear of your vehicle is damaged
- In this case, have the position and setting of the camera checked by a qualified specialist workshop. Mercedes-Benz recommends that you contact a Mercedes-Benz Light Truck Center for this purpose.

Do not use the rear view camera in these situations. Otherwise you could injure yourself or others and/or damage property including your vehicle while parking/maneuvering.

The rear view camera is an optical parking aid. It shows you the area behind the vehicle in the COMAND system display when reverse gear **R** is engaged, for example during parallel parking.

To function properly, the camera lens must be free of dirt, ice, snow, and slush. Clean the camera lens regularly, being careful not to scratch or damage the camera lens, see “Cleaning the rear view camera lens” (▷ page 319).

The rear view camera is on the tailgate above the rear window wiper.



① Rear view camera

#### Switching the rear view camera on

- ▶ Switch on the ignition (▷ page 39).
- ▶ Switch on the COMAND system. Refer to separate COMAND system operating instructions.

- ▶ Move the gear selector lever to reverse gear **R** (▷ page 162).

The area behind the vehicle appears in the COMAND system display.

**i** *The area behind the vehicle is shown in the COMAND system display as a mirror image, like in the rear view mirror.*

**i** *The image from the rear view camera will no longer be displayed if you select another function on the COMAND system while reverse gear **R** is engaged. To display the image again, disengage and reengage reverse gear **R**.*

### Switching the rear view camera off

- ▶ Move the gear selector lever to position **P**, **N** or **D**.

or

- ▶ Select another function on the COMAND system.

### Loading

#### Roof rack

This vehicle is not intended to carry items on its roof. Thus roof rails and any roof-mounted devices must not be used.

#### Warning!



Do not load items on the roof. It may cause instability during some maneuvers which could result in an accident.

#### Expanding cargo compartment

To expand the cargo compartment, you can fold forward the left and right section

- of the rear seat backrest
- of the rear seat bench

separately.

#### Warning!



Always lock seat backrest in its upright position when rear seat bench is occupied by passengers, or cargo is being carried behind the rear seat bench.

To help avoid personal injury from smaller objects being thrown around in the occupant compartment during a collision or sudden maneuver, always use partition net\* when transporting cargo (▷ page 210).

Always use the cargo tie down rings (▷ page 209).

For more information, see “Split rear seat bench” (▷ page 206).

#### Split rear seat bench

#### Warning!



Failure to assure that seat benches and seat backrests are locked into place could result in an increased chance of injury in an accident.

Never place hands under seat or near any moving parts while a seat is being adjusted.

For safety reasons, the rear seat bench must only be adjusted when the vehicle is stationary.

Never drive vehicle with the tailgate open. Deadly carbon monoxide (CO) gases may enter vehicle interior resulting in unconsciousness and death.

**!** *Before folding the rear seat backrest and the rear seat bench forward, be sure that all containers in the rear cup holder are removed.*

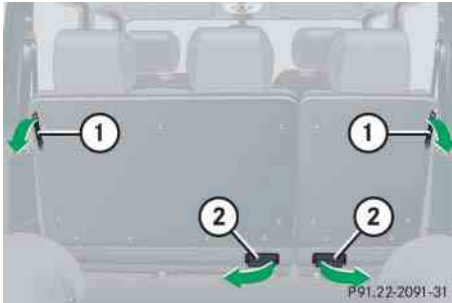

- ① Release lever for seat backrest section
- ② Release lever for seat bench section

### Folding seat backrest forward

- ▶ Remove the head restraints (▷ page 111).
- ▶ Pull release lever ① in direction of arrow and fold the seat backrest forward until it locks into place.

### Folding seat bench forward

- ▶ Fold the seat backrest forward (▷ page 207).
- ▶ Pull release lever ② in direction of arrow and fold the seat bench (together with the seat backrest) forward.

### Returning seat bench and seat backrest to original position

- ▶ Fold the seat bench (together with the seat backrest) rearward until it locks into place.
- ▶ Pull release lever ① and raise the seat backrest until it locks into place.
- ▶ Check for secure locking by pushing and pulling on the seat backrest.
- ▶ Install the head restraints (▷ page 111).

### Warning!



Failure to assure that seat benches and seat backrests are locked into place could result in an increased chance of injury in an accident.



### Loading

#### Loading instructions

##### Warning!



Always fasten items being carried as securely as possible using cargo tie-down rings and fastening materials appropriate for the weight and size of the load.

In an accident, during hard braking or sudden maneuvers, loose items will be thrown around inside the vehicle, and can cause injury to vehicle occupants unless the items are securely fastened in the vehicle.

To help avoid personal injury during a collision or sudden maneuver, exercise care when transporting cargo. Put luggage or cargo in the cargo compartment if possible. Do not pile luggage or cargo higher than the seat backrests.

Never drive vehicle with the tailgate open. Deadly carbon monoxide (CO) gases may enter vehicle interior resulting in unconsciousness and death.

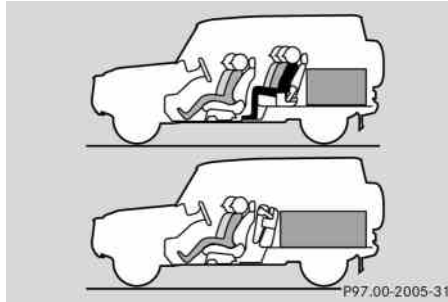

#### Load distribution

The gross vehicle weight which is the weight of the vehicle including fuel, tools, spare wheel, installed accessories, passengers and luggage/cargo must never exceed the load limit and Gross Vehicle Weight Rating (GVWR) for your vehicle as specified on the certification label located on the driver's door B-pillar (▷ page 4 12). In addition, the load must be distributed in such a way so that the weight on each axle never exceeds the Gross Axle Weight Rating (GAWR) for the front and rear axle. The GVWR and GAWR for your vehicle are indicated on the certification label which can be found on the driver's door B-pillar (▷ page 4 12).

For more information, see "Tire and Loading Information" (▷ page 28 1).

The handling characteristics of a fully loaded vehicle depend greatly on the load distribution. It is therefore recommended to load the vehicle according to the illustrations shown, with the heaviest items being placed towards the front of the vehicle.

Please pay attention to and comply with the following instructions when loading the vehicle and transporting cargo:

- Always place items being carried against front or rear seat backrests, and fasten them as securely as possible.
- The heaviest portion of the cargo should always be kept as low as possible against front or rear seat backrests.
- Always pad off sharp edges.

For additional safety when transporting cargo while the rear seats are unoccupied, fasten the outer seat belts crosswise into the opposite side buckles.



**i** *The cargo compartment is the preferred place to carry objects. The expanded cargo compartment (▷ page 206) should only be used for items which do not fit in the cargo compartment alone.*

### Cargo tie-down rings

#### Warning!



While the partition net\* (▷ page 210) will help protect you from smaller objects, it cannot prevent the movement of large, heavier objects into the passenger compartment in an accident.

Such items must be properly secured using the cargo tie-down rings in the cargo compartment floor.

### Loading

Your vehicle is equipped with four cargo tie-down rings located in the cargo compartment floor.



① Cargo tie-down rings

Carefully secure cargo by applying even load on all cargo tie-down rings with rope of sufficient strength to hold down the cargo.



### Partition net\* (MB Accessory)

#### Warning!



Make sure the partition net is properly engaged at top and bottom position and the tightening belts are securely fastened.

Never use a damaged partition net.

To help avoid personal injury from smaller objects being thrown around in the occupant compartment during a collision or sudden maneuver, always use partition net when transporting cargo.

The partition net cannot prevent the movement of large, heavier objects into the passenger compartment in an accident. Such items must be properly secured using the cargo tie-down rings (▷ page 209) in the cargo compartment floor.

Use of the partition net is a particularly important safety factor when the vehicle is loaded higher than the top of the seat backrests with smaller objects. For your safety, always use the partition net when transporting cargo.

The partition net can be installed behind the seat backrests of the rear seat bench, or behind the front seats if the rear seat bench is folded forward.

### Installing partition net behind rear seat bench

**i** Installation can be performed by opening the rear doors.



### Partition net installed behind rear seat bench

- ▶ Fold the rear seat bench forward (▷ page 207).

**i** This cannot be done by folding the rear seat backrest forward.

### Hanging up partition net



- ① Partition net
- ② Holder

- ▶ Hang partition net ① on holder ② and push forward in direction of the arrow.

### Loading

#### *Pulling partition net tight*

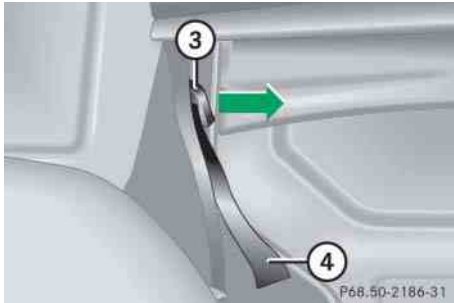

- ③ Lift tensioner
- ④ Tightening belt

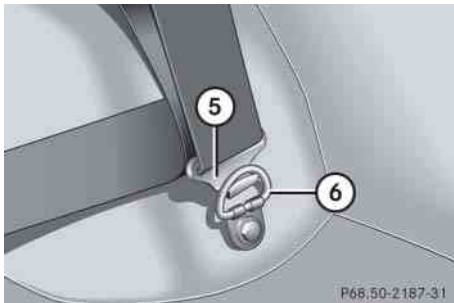

- ⑤ Belt hook
- ⑥ Cargo tie-down ring

Lift tensioner ③ on tightening belt ④ must point in direction of the windshield (indicated by the arrow).

- ▶ Use lift tensioner ③ to set the length of tightening belt ④ to cargo tie-down ring ⑥.
- ▶ Hook belt hook ⑤ into cargo tie-down ring ⑥.
- ▶ Pull tightening belt ④ by the loose end until the partition net is slightly pulled tight.
- ▶ Fold the rear seat bench rearward until it locks into place.  
The partition net will be tightened by the rear seat bench.
- ▶ After driving a short distance, make sure the partition net is still tight and, if necessary, pull it tight again.

#### **Installation partition net behind front seats**



#### **Partition net installed behind front seats**

- ▶ Fold the rear seat bench (together with the rear seat backrest) forward (▷ page 207).

### *Hang up partition net*



- ① Partition net
- ② Holder

- ▶ Hang partition net ① on holder ② and push forward in direction of the arrow.

### *Pulling partition net tight*

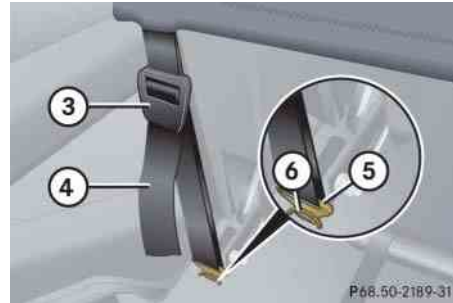

- ③ Lift tensioner
- ④ Tightening belt
- ⑤ Belt hook
- ⑥ Cargo tie-down ring

Lift tensioner ③ on tightening belt ④ must point in direction of the tailgate.

- ▶ Use lift tensioner ③ to set the length of tightening belt ④ to cargo tie-down ring ⑥.
- ▶ Hook belt hook ⑤ into cargo tie-down ring ⑥.

- ▶ Pull tightening belt ④ by the loose end until the partition net is pulled tight.
- ▶ After driving a short distance, make sure the partition net is still tight and, if necessary, pull it tight again.

### **Loosening partition net**

- ▶ Loosen tightening belt ④ by pulling lift tensioner ③ upward.
- ▶ Remove belt hook ⑤ from cargo tie-down ring ⑥.

### **Removing and storing partition net**

- ▶ Take partition net ① out of holder ②.
- ▶ Roll up partition net and secure it.
- ▶ Store partition net behind the rear seat bench.

### Loading

#### Cargo compartment cover blind

The cargo compartment cover blind can be installed behind the rear seat bench.

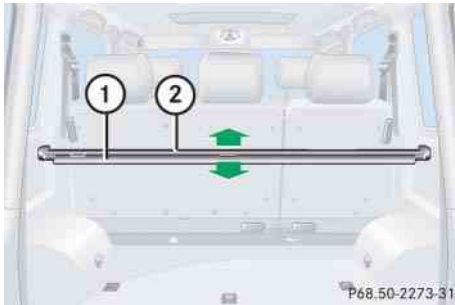

- ① Rear seat bench cover blind
- ② Tailgate cover blind

#### Rolling out blind

- ▶ Grip the blind strap and pull blind ① forward across the cargo compartment.
- ▶ Engage blind into the mounts on the rear seat backrest and release.
- ▶ Grip the blind strap and pull blind ② rearward across the cargo compartment.
- ▶ Engage blind into the mounts to the left and right of the tailgate.

#### Rolling up blind

- ▶ Disengage blind ① from the mounts on the rear seat backrest and guide retraction by its blind strap.
- ▶ Disengage blind ② from the mounts to the left and right of the tailgate and guide retraction by its blind strap.

#### Removing and installing blind

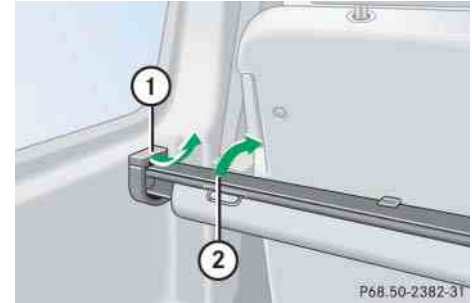

- ① Latch
- ② Blind

#### Removing blind

- ▶ Roll the blind up (▷ page 214).
- ▶ Open latch ① on the right and left side of blind ② in direction of the arrow.
- ▶ Pull blind ② out upwards.

#### Installing blind

- ▶ Place blind into recesses.
- ▶ Press the right and left side of blind down until blind locks into place.

## ▼ Useful features

### Storage compartments

#### Warning!



To help avoid personal injury during a collision or sudden maneuver, exercise care when storing objects in the vehicle. Put luggage or cargo in the cargo compartment if possible. Do not pile luggage or cargo higher than the seat backrests.

Always use partition net\* when transporting cargo. Partition net\* cannot secure hard or heavy objects.

Parcel nets cannot secure hard or heavy objects.

Keep compartment lids closed. This will help to prevent stored objects from being thrown about and injuring vehicle occupants during

- braking
- vehicle maneuvers
- an accident

#### Warning!



Do not load items on the roof. It may cause instability during some maneuvers which could result in an accident.

### Glove box

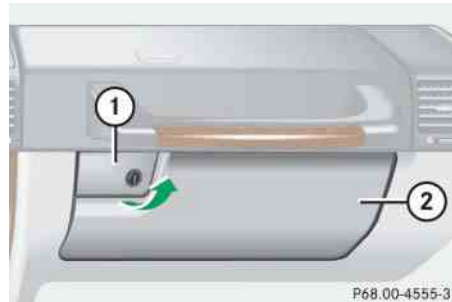

- ① Glove box lid release
- ② Glove box lid

### Opening the glove box

- ▶ Pull glove box lid release ① in direction of arrow.

Glove box lid ② opens downward.

**i** The glove box is illuminated with SmartKey in starter switch position 1 or 2 when opening the lid.

### Closing the glove box

- ▶ Push glove box lid ② up to close.



### Useful features

#### **Locking and unlocking the glove box separately**

You can lock the glove box separately, e.g. when the vehicle is in the shop for service.

- ▶ Take the mechanical key out of the SmartKey (▷ page 370).

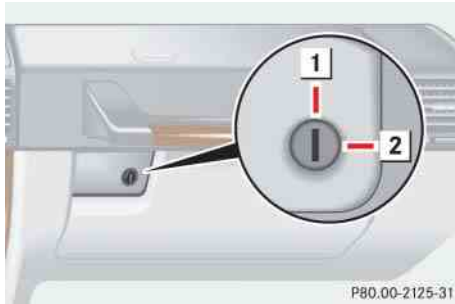

1 Unlocking the glove box

2 Locking the glove box

- ▶ Insert the mechanical key into the glove box lock.
- ▶ Turn the mechanical key to position **2** to lock the glove box.
- ▶ Turn the mechanical key to position **1** to unlock the glove box.



**i** *The glove box can only be locked or unlocked with the mechanical key.*

#### **Storage compartments/telephone\* tray below armrest**

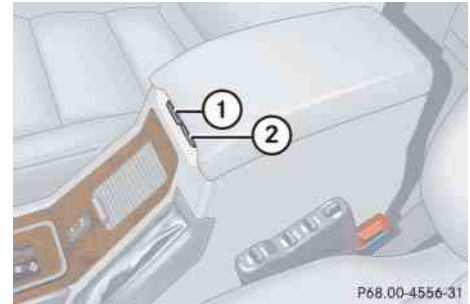
A flat storage/telephone\* tray with a deeper storage compartment underneath is located below the armrest cover. Both can be opened separately.



- ① Button to open storage/telephone\* tray
- ② Button to open storage compartment

**i** *The contact plate for various mobile phone cradles\* (▷ page 228), the Roadside Assistance button  (▷ page 232) and the Information button  (▷ page 233) are located in the storage/telephone\* tray.*

### Opening the storage/telephone\* tray

- ▶ Press button ① and lift up armrest cover.

**i** Located in the cover of the storage/telephone\* tray is a storage area for small items such as checks.

### Closing the storage/telephone\* tray

- ▶ Lower armrest cover until it engages in lock.

### Opening the storage compartment

- ▶ Press button ② and lift up armrest cover.

**i** In the storage compartment there is a storage area for up to three CDs.

### Closing the storage compartment

- ▶ Lower armrest cover until it engages in lock.

### Storage box in front of armrest

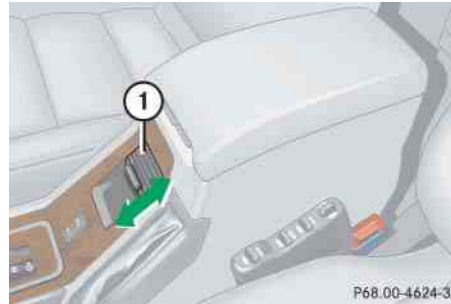

- ① Storage box cover

### Opening the storage box

- ▶ Slide storage box cover ① backward.

### Closing the storage box

- ▶ Slide storage box cover ① forward.

### Ruffled storage bags

#### Warning!



The ruffled storage bag is intended for storing light-weight items only.

Heavy objects, objects with sharp edges or fragile objects may not be transported in the ruffled storage bag. In an accident, during hard braking, or sudden maneuvers, they could be thrown around inside the vehicle and cause injury to vehicle occupants.

The ruffled storage bag cannot protect transported goods in the event of an accident.

### Useful features

Ruffled storage bags are located on the front seat backrests.

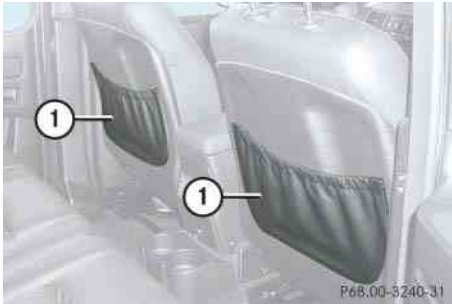

① Ruffled storage bag

### Parcel net in front passenger footwell

#### Warning!



The parcel net is intended for storing light-weight items only.

Heavy objects, objects with sharp edges or fragile objects may not be transported in the parcel net. In an accident, during hard braking, or sudden maneuvers, they could be thrown around inside the vehicle and cause injury to vehicle occupants.

The parcel net cannot protect transported goods in the event of an accident.

**!** *When large objects are stored in the parcel net, do not slide the seat fully forward, it could damage them.*

A small convenience parcel net is located in the front passenger footwell. It is for small and light items, such as road maps, mail, etc.

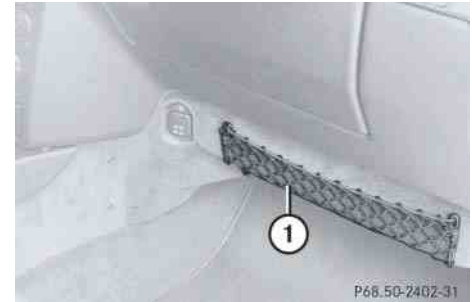

① Parcel net

## Cup holders

### Warning!



In order to help prevent spilling liquids on vehicle occupants and/or vehicle equipment, only use containers that fit into the cup holder. Use lids on open containers and do not fill containers to a height where the contents, especially hot liquids, could spill during braking, vehicle maneuvers, or in an accident. Liquids spilled on vehicle occupants may cause serious personal injury. Liquids spilled on vehicle equipment may cause damage not covered by the Mercedes-Benz Limited Warranty.

When not in use, keep the cup holder closed. An open cup holder may cause injury to you or others when contacted during braking, vehicle maneuvers, or in an accident.

Keep in mind that objects placed in the cup holder may come loose during braking, vehicle maneuvers, or in an accident and be thrown around in the vehicle interior. Objects thrown around in the vehicle interior may cause an accident and/or serious personal injury.

### *Cup holder next to armrest*

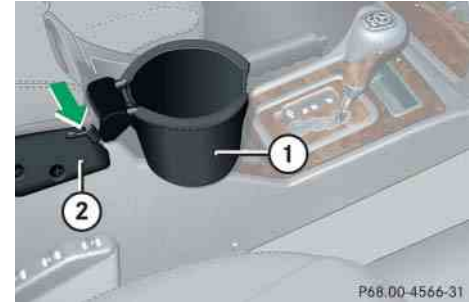

- ① Cupholder
- ② Cupholder base

- ▶ Place bracket of cup holder ① into recess (indicated by arrow) of cupholder base ②.

If the cup holder is no longer in use, it can for example, be stored in the glove box or storage compartment below the armrest.

### Useful features

#### Cup holder in front passenger footwell



#### ① Cupholder

- ▶ Swing cupholder ① upwards until it clicks into place.

**!** Fold the cup holder closed before moving the front passenger seat fully forward.

#### Cup holder in rear passenger footwell



#### Rear cup holder

**!** Before folding the seat backrest forward and the rear seat bench down, be sure that all containers in the rear cup holder are removed.

#### Ashtrays

Your vehicle is equipped with an ashtray and a cigarette lighter located in the center console and two ashtrays located in the rear passenger compartment (▷ page 221).

#### Ashtray in the center console

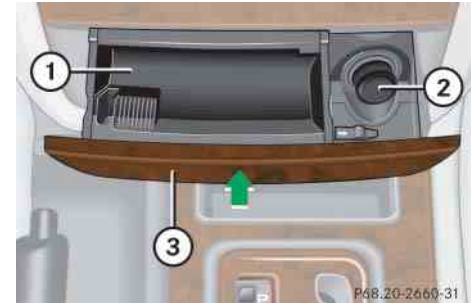

- ① Ashtray
- ② Cigarette lighter (▷ page 222)
- ③ Cover plate

### Opening the ashtray

- ▶ Briefly touch at top of cover plate ③.  
The ashtray opens automatically.

### Removing the ashtray insert

#### Warning!



Remove ashtray only with vehicle standing still. Set the parking brake to secure the vehicle from movement. Move gear selector lever to neutral position **N**. With the gear selector lever in neutral position **N** turn off the engine.

- ▶ Secure the vehicle from movement by setting the parking brake.
- ▶ Move the gear selector lever to neutral position **N**.  
Now you have more room to take out the ashtray insert.
- ▶ Turn off the engine.

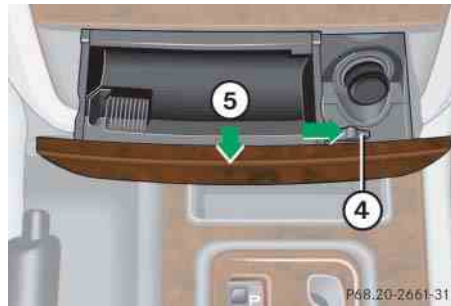

④ Sliding button

⑤ Ashtray insert

- ▶ Push sliding button ④ to the right.

Ashtray insert ⑤ disengages and protrudes a short distance.

- ▶ Remove ashtray insert ⑤ from ashtray frame in direction of the arrow.

### Reinstalling the ashtray insert

- ▶ Push ashtray insert ⑤ down into the ashtray frame until it engages.
- ▶ Push at top of cover plate ③ to close the ashtray.  
Cover plate ③ engages.

### Ashtrays in the rear passenger compartment

There is located one ashtray on each rear passenger door.



① Cover

② Catch

③ Ashtray insert

### Useful features

#### Opening the ashtray

- ▶ Pull at top of cover ①.

#### Removing the ashtray insert

- ▶ Push down on catch ②.
- ▶ Pull out ashtray insert ③.

#### Reinstalling the ashtray insert

- ▶ Position ashtray insert ③.
- ▶ Push at top of cover ① to close the ashtray.

#### Cigarette lighter

##### Warning!



Never touch the heating element or sides of the cigarette lighter; they are extremely hot. Hold the knob only.

Make sure that any children traveling with you do not injure themselves or start a fire with the hot cigarette lighter.

When leaving the vehicle, always remove the SmartKey from the starter switch, take it with you, and lock the vehicle. Do not leave children unattended in the vehicle, or with access to an unlocked vehicle. Unsupervised use of vehicle equipment may cause an accident and/or serious personal injury.

- ▶ Switch on the ignition (> page 39).



#### ① Cigarette lighter

- ▶ Briefly touch at top of the cover plate. The ashtray opens automatically.
- ▶ Push in cigarette lighter ①. The cigarette lighter will pop out automatically when hot.

**!** The lighter socket can accommodate 12 V DC electrical accessories (up to a maximum of 180 W) designed for use with the standard “cigarette lighter” plug type. Keep in mind, however, that connecting accessories to the lighter socket (for example extensive connecting and disconnecting, or using plugs that do not fit properly) can damage the lighter socket. With the socket damaged, the lighter may no longer be able to be placed in the heating (pushed-in) position, or the lighter may pop out too early with the lighter not hot enough.

To help avoid damaging the cigarette lighter socket, we recommend connecting 12 V DC electrical accessories designed for use with the standard “cigarette lighter” plug type to the 12 V power outlets (▷ page 223) in your vehicle whenever possible.

**i** If the engine is off, and the cigarette lighter is being used extensively, the vehicle battery may become discharged.

## Electrical outlet

**!** If you use all power outlets in the vehicle, make sure that the maximum current drawn does not exceed 15 A.

**i** The power outlets can be used to accommodate 12 V DC electrical accessories (e.g. auxiliary lamps) up to a maximum of 180 W. If the engine is off, the battery may become discharged if used for long periods of time.

Power outlets are located

- in the front passenger footwell (▷ page 223)
- in the rear passenger footwell (▷ page 224)
- on the left-hand side of the cargo compartment (▷ page 224)

## Power outlet in front passenger footwell



- ▶ Switch on the ignition (▷ page 39).
- ▶ Flip up cover and insert electrical plug (cigarette lighter type).



### Useful features

#### Power outlet in rear passenger footwell



- ▶ Switch on the ignition (▷ page 39).
- ▶ Flip up cover and insert electrical plug (cigarette lighter type).

#### Power outlet in cargo compartment

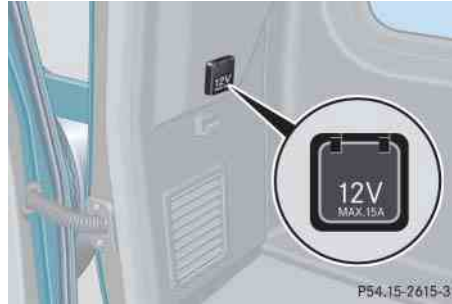

- ▶ Switch on the ignition (▷ page 39).
- ▶ Flip up cover and insert electrical plug (cigarette lighter type).

#### Floormats

##### Warning!



Whenever you are using floormats, make sure there is enough clearance and the floormats are securely fastened.

Floormats should always be securely fastened using the eyelets and retainer pins.

Before driving off, check that the floormats are securely in place and adjust them if necessary. A loose floormat could slip and hinder proper functioning of the pedals.

Do not place several floormats on top of each other as this may impair pedal movement.

**i** To install or remove the floormat more easily, move the driver's seat or front passenger seat as far to the rear as possible (▷ page 42).

## Heated steering wheel

The steering wheel heating warms up the leather area of the steering wheel.

The stalk is located on the lower left-hand side of the steering wheel.

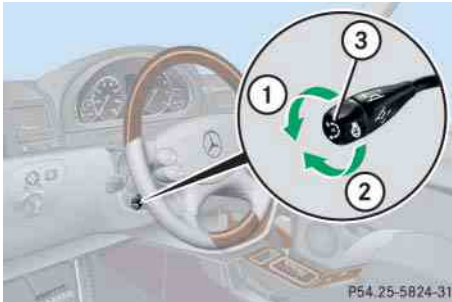

- ① Switching on
- ② Switching off
- ③ Indicator lamp

## Switching on

- ▶ Switch on the ignition (▷ page 39).
- ▶ Turn switch at the tip of stalk in direction of arrow ①.

The steering wheel is heated.  
Indicator lamp ③ comes on.

**i** The steering wheel heating is temporarily suspended while the indicator lamp ③ remains on when

- the temperature of the vehicle interior is above 86°F (30°C)
- the temperature of the steering wheel is above 95°F (35°C)

When these conditions do not apply anymore, steering wheel heating continues.

## Switching off

- ▶ Turn switch at the tip of stalk in direction of arrow ②.

The heated steering wheel is switched off.

Indicator lamp ③ goes out.

**i** Indicator lamp ③ flashes or goes out

- in case of power surge or undervoltage
- in case of a steering wheel heating malfunction

**i** The steering wheel heating switches off automatically when you remove the SmartKey from the starter switch.

For information on adjusting the steering wheel, see “Steering wheel” (▷ page 44).

### Useful features

#### Telephone\*

##### Warning!



Never operate radio transmitters equipped with a built-in or attached antenna (i.e. without being connected to an external antenna) from inside the vehicle while the engine is running. Doing so could lead to a malfunction of the vehicle's electronic system, possibly resulting in an accident and/or serious personal injury.

Radio transmitters, such as a portable telephone or a citizens band unit, should only be used inside the vehicle if they are connected to an antenna that is installed on the outside of the vehicle.

The external antenna must be approved by Mercedes-Benz. Please contact an authorized Mercedes-Benz Light Truck Center for information on the installation of an approved external antenna. Refer to the radio transmitter operation instructions regarding use of an external antenna.

##### Warning!



Please do not forget that your primary responsibility is to drive the vehicle. A driver's attention to the road must always be his/her primary focus when driving. For your safety and the safety of others, we recommend that you pull over to a safe location and stop before placing or taking a telephone call.

If you choose to use the telephone<sup>1</sup> while driving, please use the hands-free device and only use the telephone when road, weather and traffic conditions permit. Some jurisdictions prohibit the driver from using a mobile telephone while driving a vehicle.

Only operate the COMAND system<sup>1</sup> if road, weather and traffic conditions permit.



Bear in mind that at a speed of just 30 mph (approximately 50 km/h), your vehicle is covering a distance of 44 feet (approximately 14 m) every second.

<sup>1</sup> Observe all legal requirements.

 Various mobile phone cradles can be installed in the front center armrest, see separate installation instructions for the mobile phone cradle. These mobile phone cradles can be obtained from an authorized Mercedes-Benz Light Truck Center.

*The functions and services available to you while using the mobile phone depend on your service provider and the type of mobile phone you are using. See also separate operating manual for instructions on how to use the mobile phone.*

When the mobile phone is inserted in the cradle, you can operate the telephone using the following devices:

- mobile phone keypad
- COMAND system (see separate operating instructions)
- buttons  and  on the multi-function steering wheel (▷ page 134)
- Voice Control System\* (see separate operating instructions)

Please note that these functions are only available with Mercedes-Benz approved mobile phones. Please contact an authorized Mercedes-Benz Light Truck Center for information on features available for your mobile phone of choice.

The cradle is located in the armrest.

- ▶ Open the telephone tray (▷ page 216).

### Inserting mobile phone in mobile phone cradle

Once the mobile phone has been inserted in the mobile phone cradle, you have to use the hands-free device to respond during phone calls.

**!** Do not try to remove the mobile phone along with the cradle. You could otherwise damage the mobile phone cradle.

- ▶ If applicable, remove the cover for the external antenna connection from the back of the mobile phone and store it in a safe place. Be sure to comply with the mobile phone's operating instructions as well.



### Example illustration

- ① Inserting the mobile phone
  - ② Connector contact
  - ③ Mobile phone cradle
- ▶ Slide the lower end of the mobile phone into connector contact ② on cradle ③.

- ▶ Push the top of the mobile phone in direction of arrow ①, until the lug on the mobile phone release button engages.

The mobile phone is connected to the network via the external antenna.

The mobile phone is linked to the hands-free device and the multi-function steering wheel.

The battery is charged depending on its charge status and the position of the SmartKey in the starter switch. The charge procedure will be indicated in the mobile phone's display.

You can place or receive phone calls. You can control other functions of the mobile phone via the control system (▷ page 159), the Voice Control System\* (see separate operating instructions), or the COMAND system (see separate operating instructions).

▷▷

### Useful features

- ▷▷ **i** When you take the SmartKey out of the starter switch, the mobile phone remains switched on for approximately 10 minutes. If you place or receive a call during this time, the mobile phone switches off 10 minutes after the call has been completed.

#### Removing mobile phone from mobile phone cradle



#### Example illustration

- ① Release catch for mobile phone
- ② Mobile phone cradle

**i** When using a flip-style mobile phone, open flip top before removing from the cradle while a call is connected. Otherwise, the call will be disconnected.

- ▶ Press release catch in direction of arrow ① and take mobile phone out of mobile phone cradle ②.

#### Changing mobile phone cradle

If you require a different cradle for your mobile phone, remove the present cradle before installing a new one.

#### Removing an existing mobile phone cradle



#### Example illustration

- ① To release the mobile phone cradle
- ② To remove the mobile phone cradle
- ③ Mobile phone cradle

- ▶ Press release button in direction of arrow ① and take mobile phone cradle ③ out in direction of arrow ②.

#### Installing a different mobile phone cradle

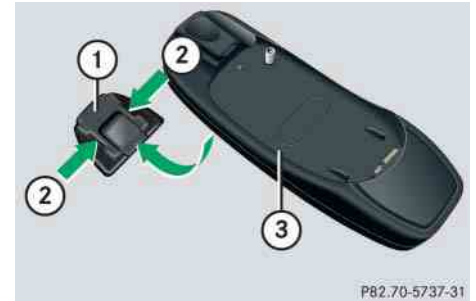

#### Example illustration

- ① Contact plate
- ② Recesses
- ③ Mobile phone cradle

- ▶ Insert mobile phone cradle ③ into recesses ② of contact plate ①.
- ▶ Push mobile phone cradle ③ forward until it engages.

## Tele Aid

**!** *The initial activation of the Tele Aid system may only be performed by completing the subscriber agreement and placing an acquaintance call using the Information button . Failure to complete either of these steps will result in a system that is not activated.*

*If you have any questions regarding activation, please call the Response Center at 1-800-756-9018 (in the USA) or 1-888-923-8367 (in Canada).*

Shortly after the completion of your Tele Aid acquaintance call, you will receive a user ID and password. By visiting [www.mbusa.com](http://www.mbusa.com) and selecting “Tele Aid” (USA only), you will have access to account information, remote door unlock and more.



## The Tele Aid system



(Telematic Alarm Identification on Demand)

The Tele Aid system consists of three types of response:



- automatic and manual emergency
- roadside assistance
- information

The Tele Aid system is operational providing that the vehicle’s battery is charged, properly connected, not damaged and cellular and GPS coverage are available.

The speaker volume of a Tele Aid call can be adjusted by using the volume control on the COMAND system headunit or on the multifunction steering wheel. To raise, turn the rotary volume control on the COMAND system headunit clockwise or press button  on the multifunction steering wheel. To lower, turn the rotary volume control on the COMAND system headunit counterclockwise or press button  on the multifunction steering wheel.

- ▶ To activate, press the SOS button, the Roadside Assistance button  or the Information button , depending on the type of response required.

**i** *The SOS button is located in the overhead control panel (▷ page 231).*



*The Roadside Assistance button  (▷ page 232) and the Information button  (▷ page 233) are located below the center armrest cover.*

**!** *The Tele Aid system utilizes the cellular network for communication and the GPS (Global Positioning System) satellites for vehicle location. If either of these signals are unavailable, the Tele Aid system may not function and if this occurs, assistance must be summoned by other means.*

### Useful features

**i** When a Tele Aid call has been initiated, the COMAND system audio is muted and the selected mode (radio, CD etc.) pauses. The optional cellular phone (if installed) inserted in cradle switches off. If you must use this phone, we recommend that you use it only with the vehicle at a standstill in a safe location. Remove the phone from the cradle and place the call. The navigation system (if engaged) will continue to run. The display in the instrument cluster is available for use, and spoken commands are only available by pressing the RPT button on the COMAND system. A pop-up window will appear in the COMAND system display to indicate that a Tele Aid call is in progress. After the Tele Aid call has ended, the optional cellular phone inserted in the cradle switches on again. A PIN entry might be necessary.

### System self-check

Initially, after switching on the ignition, malfunctions are detected and indicated (the indicator lamps in the SOS button, the Roadside Assistance button  and the Information button  stay on longer than 10 seconds or do not come on). The message `Tele Aid inoperative` appears in the multifunction display.

#### Warning!



If the indicator lamps on the SOS button, on the Roadside Assistance button, and/or on the Information button remain illuminated continuously in red and/or the message `Tele Aid inoperative` is displayed in the multifunction display after the system self-check, a malfunction in the system has been detected.

If a malfunction is indicated as outlined above, the system may not operate as expected. Have the system checked at the nearest Mercedes-Benz Light Truck Center as soon as possible.

### Emergency calls

An emergency call is initiated automatically following an accident in which the emergency tensioning devices (ETDs) or air bags deploy.

An emergency call can also be initiated manually by opening the cover next to the interior rear view mirror labeled SOS, then briefly pressing the button located under the cover. See (▷ page 231) for instructions on initiating an emergency call manually.

Once the emergency call is in progress, the indicator lamp on the SOS button will begin to flash. The message `Connecting call` appears in the multifunction display. When the connection is established, the message `Call connected` appears in the multifunction display. All information relevant to the emergency, such as the location of the vehicle (determined by the GPS satellite location system), vehicle model, identification number and color are generated.

A voice connection between the Response Center and the occupants of the vehicle will be established automatically soon after the emergency call has been initiated. The Response Center will attempt to determine more precisely the nature of the accident provided they can speak to an occupant of the vehicle.

The Tele Aid system is available if

- it has been activated and is operational. Activation requires a subscription for monitoring services, connection and cellular air time
- vehicle battery power is available
- the relevant cellular phone network and GPS signals are available and pass the information on to the Response Center

**i** Location of the vehicle on a map is only possible if the vehicle is able to receive signals from the GPS satellite network and pass the information on to the Response Center.

### Warning!



If the indicator lamp in the SOS button is flashing continuously and there was no voice connection to the Response Center established, then the Tele Aid system could not initiate an emergency call (e.g. the relevant cellular phone network is not available). The message *Call failed* appears in the multifunction display for approximately 10 seconds.

Should this occur, assistance must be summoned by other means.

### Initiating an emergency call manually



- ① Cover
- ② SOS button

- ▶ Briefly press on cover ①.

The cover opens.

- ▶ Press SOS button ② briefly.

The indicator lamp in SOS button ② will flash until the emergency call is concluded.





### Useful features

- ▷▷ Wait for a voice connection to the Response Center.
- ▶ Close cover ① after the emergency call is concluded.

#### Warning!



If you feel at any way in jeopardy when in the vehicle (e.g. smoke or fire in the vehicle, vehicle in a dangerous road location), please do not wait for voice contact after you have pressed the emergency button. Carefully leave the vehicle and move to a safe location. The Response Center will automatically contact local emergency officials with the vehicle's approximate location if they receive an automatic SOS signal and cannot make voice contact with the vehicle occupants.

#### Roadside Assistance button

The Roadside Assistance button is located below the center armrest cover.

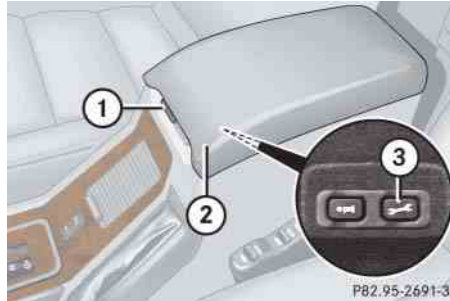

- ① Button to open telephone tray
- ② Armrest cover
- ③ Roadside Assistance button

- ▶ Press button ① and lift up armrest cover ②.

- ▶ Press and hold button ③ (for longer than 2 seconds).

A call to a Mercedes-Benz Roadside Assistance dispatcher will be initiated. The button will flash while the call is in progress. The message *Connecting call* will appear in the multifunction display.

When the connection is established, the message *Call connected* appears in the multifunction display. The Tele Aid system will transmit data generating the vehicle identification number, model, color and location (subject to availability of cellular and GPS signals).

**i** While the call is connected you can change to the navigation menu by pressing the NAV button on the COMAND system headunit.



A voice connection between the Roadside Assistance dispatcher and the occupants of the vehicle will be established.

- ▶ Describe the nature of the need for assistance.

The Mercedes-Benz Roadside Assistance dispatcher will either dispatch a qualified Mercedes-Benz technician or arrange to tow your vehicle to the nearest Mercedes-Benz Light Truck Center. For services such as labor and/or towing, charges may apply. Refer to the Roadside Assistance Manual for more information.

The following is only available in the USA:

- Sign and Drive services: Services such as jump start, a few gallons of fuel or the replacement of a flat tire with the vehicle spare tire are obtainable.

**i** The indicator lamp on the Roadside Assistance button  remains illuminated in red for approximately 10 seconds during the system self-check after switching on the ignition (together with the SOS button and the Information button ).

See system self-check (▷ page 230) if the indicator lamp does not come on in red or stays on longer than approximately 10 seconds.

If the indicator lamp on the Roadside Assistance button  is flashing continuously and there was no voice connection to the Response Center established, then the Tele Aid system could not initiate a Roadside Assistance call (e.g. the relevant cellular phone network was not available). The message *Call failed* appears in the multifunction display.

Roadside Assistance calls can be terminated using the  button on the multifunction steering wheel or the END button on the COMAND system headunit.

### Information button

The Information button  is located below the center armrest cover.

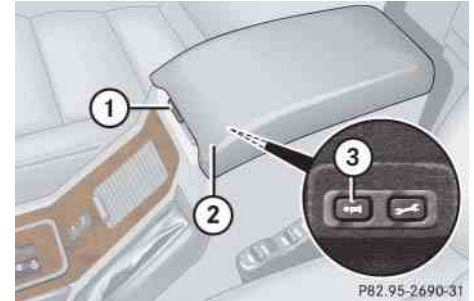

- ① Button to open telephone tray
- ② Armrest cover
- ③ Information button 

- ▶ Press button ① and lift up armrest cover ②.



### Useful features

- ▷▷▶ Press and hold button  (for longer than 2 seconds).



A call to the Customer Assistance Center will be initiated. The button will flash while the call is in progress. The message **Connecting call** will appear in the multifunction display.

When the connection is established, the message **Call connected** appears in the multifunction display. The Tele Aid system will transmit data generating the vehicle identification number, model, color and location (subject to availability of cellular and GPS signals).

 *While the call is connected, you can change to the navigation menu by pressing the NAV button on the COMAND system headunit.*

A voice connection between the Customer Assistance Center representative and the occupants of the vehicle will be established. Information regarding the operation of your vehicle, the nearest Mercedes-Benz Light Truck Center or Mercedes-Benz USA products and services is available to you.

For more details concerning the Tele Aid system, please visit [www.mbusa.com](http://www.mbusa.com) and use your ID and password (sent to you separately) to learn more (USA only).

 *The indicator lamp in the Information button  remains illuminated in red for approximately 10 seconds during the system self-check after switching on the ignition (together with the SOS button and the Roadside Assistance button ).*

*See system self-check (▷ page 230) if the indicator lamp does not come on in red or stays on longer than approximately 10 seconds.*

*If the indicator lamp in the Information button  is flashing continuously and there was no voice connection to the Response Center established, then the Tele Aid system could not initiate an Information call (e.g. the relevant cellular phone network is not available). The message **Call failed** appears in the multifunction display.*

*Information calls can be terminated using the  button on the multifunction steering wheel or the END button on the COMAND system headunit.*

**!** *If the indicator lamps do not start flashing after pressing one of the buttons or remain illuminated (in red) at any time, the Tele Aid system has detected a malfunction or the service is not currently active, and may not initiate a call. Visit your authorized Mercedes-Benz Light Truck Center and have the system checked or contact the Response Center at 1-800-756-9018 (in the USA) or 1-888-923-8367 (in Canada) as soon as possible.*

### Call priority

If other service calls such as a Roadside Assistance call or Information call are active, an Emergency call is still possible. In this case, the Emergency call will take priority and override all other active calls.

**i** *The indicator lamp in the respective button flashes until the call is concluded. Emergency calls can only be terminated by a Response Center or Customer Assistance Center representative, whereas Roadside Assistance and Information calls can also be terminated using the  button on the multifunction steering wheel or the END button on the COMAND system headunit.*

**!** *If the indicator lamp continues to flash or the system does not reset, contact the Response Center at 1-800-756-9018 (in the USA) or 1-888-923-8367 (in Canada), or Mercedes-Benz Customer Assistance at 1-800-FOR-MERCEdes (1-800-367-6372) in the USA or Customer Service at 1-800-387-0100 in Canada.*

### Remote door unlock

In case you have locked your vehicle unintentionally (e.g. SmartKey inside vehicle), and the reserve SmartKey is not handy:

- ▶ Contact the Mercedes-Benz Response Center at 1-800-756-9018 (in the USA) or 1-888-923-8367 (in Canada).  
You will be asked to provide your password which you provided when you completed the subscriber agreement.
- ▶ Then return to your vehicle at the time arranged with the Response Center and press the tailgate lock for a minimum of 20 seconds until the SOS button is flashing.

The message **Connecting call** appears in the multifunction display.

As an alternative, you may unlock the vehicle via Internet using the ID and password sent to you shortly after the completion of your acquaintance call.

### Useful features

The Response Center will then unlock your vehicle with the remote door unlocking feature.

**i** *The remote door unlock feature is available if the relevant cellular phone network is available.*

*The SOS button will flash and the message Connecting call will appear in the multi-function display to indicate receipt of the door unlock command.*

*Once the vehicle is unlocked, a Response Center specialist may attempt to establish voice contact with the vehicle occupants.*

*If the tailgate lock was pressed for more than 20 seconds before door unlock authorization was received by the Response Center, you must wait 15 minutes before pressing the tailgate lock again.*

### Stolen Vehicle Recovery services

In the event your vehicle was stolen:

- ▶ Report the incident to the police.  
The police will issue a numbered incident report.
- ▶ Pass this number on to the Mercedes-Benz Response Center along with your password issued to you when you subscribed to the service.

The Response Center will then attempt to covertly contact the vehicle's Tele Aid system. Once the vehicle is located, the Response Center will contact the local law enforcement and you. The vehicle's location will only be provided to law enforcement.

**i** *When the anti-theft alarm stays on for more than 30 seconds, a call is initiated automatically to the Response Center. For more information, see "Anti-theft systems" (> page 96).*

### Garage door opener

---

The integrated remote control is capable of operating up to three separately controlled devices. It provides a convenient way to replace up to three hand-held remote controls used to operate devices such as garage door openers, gate openers, or other devices compatible with HomeLink® or some other systems.

Before the integrated remote control can be used, it must be programmed to the garage door opener, gate operator or other device you wish to operate. See the following instructions for programming information.

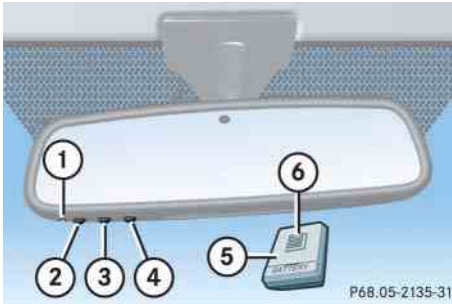

### Interior rear view mirror with integrated remote control

- ① Indicator lamp
  - ② ③ ④ Signal transmitter button
- Needed for programming (not part of vehicle equipment):
- ⑤ Hand-held remote control of garage door opener, gate operator or other device
  - ⑥ Hand-held remote control button

### Warning!



Before programming the integrated remote control to a garage door opener or gate operator, make sure people and objects are out of the way of the device to prevent potential harm or damage. When programming a garage door opener, the door moves up or down. When programming a gate operator, the gate opens or closes.

Do not use the integrated remote control with any garage door opener that lacks safety stop and reverse features as required by U.S. federal safety standards (this includes any garage door opener model manufactured before April 1, 1982).

A garage door that cannot detect an object - signaling the door to stop and reverse - does not meet current U.S. federal safety standards.

When programming a garage door opener, park the vehicle outside the garage.

Do not run the engine while programming the integrated remote control. Inhalation of exhaust gas is hazardous to your health. All exhaust gas contains carbon monoxide (CO), and inhaling it can cause unconsciousness and possible death.

### Programming the integrated remote control

Step 1:

- ▶ Switch on the ignition (▷ page 39). ▷▷

### Useful features

#### ▷▷Step 2:

- ▶ If you have previously programmed a signal transmitter button and wish to retain its programming, proceed to step 3.

If you are programming the integrated remote control for the first time, press and hold outer signal transmitter buttons ② and ④ and release them only when indicator lamp ① begins to flash after approximately 20 seconds (do not hold the button for longer than 30 seconds). This procedure erases any previous settings for all three channels and initializes the memory.

If you later wish to program a second and/or third hand-held transmitter to the remaining two signal transmitter buttons, do not repeat this step and begin directly with step 3.

#### Step 3:

- ▶ Hold end of hand-held remote control ⑤ of the device you wish to train approximately 2 to 5 in (5 to 12 cm) away from signal transmitter button (②, ③ or ④) to be programmed, while keeping indicator lamp ① in view.

#### Step 4:

- ▶ Using both hands, simultaneously press hand-held remote control button ⑥ and the desired signal transmitter button (②, ③, or ④). Do not release the buttons until step 5 is completed.

Indicator lamp ① will flash, first slowly and then rapidly.

**i** Indicator lamp ① flashes immediately the first time the signal transmitter button is programmed. If this button has already been programmed, the indicator lamp will only start flashing after 20 seconds.

#### Step 5:

- ▶ After indicator lamp ① changes from a slow to a rapidly flashing light, release the hand-held remote control button and the signal transmitter button.

#### Step 6:

- ▶ Press and hold the just-trained signal transmitter button (②, ③, or ④) and observe indicator lamp ①.

If indicator lamp ① stays on constantly, programming is complete and your device should activate when the respective signal transmitter button (②, ③, or ④) is pressed and released.

**i** If indicator lamp ① flashes rapidly for about 2 seconds and then turns to a constant light, continue with programming steps 8 through 12 as your garage door opener may be equipped with the “rolling code” feature.

#### Step 7:

- ▶ To program the remaining two signal transmitter buttons, repeat the steps above starting with step 3.

### Rolling code programming

To train a garage door opener (or other rolling code devices) with the rolling code feature, follow these instructions after completing the “Programming” portion (steps 1 through 6) of this text. (A second person may make the following training procedures quicker and easier.)

Step 8:

- ▶ Locate “training” button on the garage door opener motor head unit.

Exact location and color of the button may vary by garage door opener brand. Depending on manufacturer, the “training” button may also be referred to as “learn” or “smart” button. If there is difficulty locating the transmitting button, refer to the garage door opener Operator’s manual.

Step 9:

- ▶ Press the “training” button on the garage door opener motor head unit.

The “training light” is activated.

You have 30 seconds to initiate the following steps.

Step 10:

- ▶ Return to the vehicle and firmly press, hold for 2 seconds and release the programmed signal transmitter button (②, ③, or ④).

Step 11:

- ▶ Press, hold for 2 seconds and release same signal transmitter button a second time to complete the training process.

**i** *Some garage door openers (or other rolling code equipped devices) may require you to press, hold for 2 seconds and release the same signal transmitter button a third time to complete the training process.*

Step 12:

- ▶ Confirm the garage door operation by pressing the programmed signal transmitter button (②, ③, or ④).

Step 13:

- ▶ To program the remaining two signal transmitter buttons, repeat the steps above starting with step 3.

### Gate operator/Canadian programming

Canadian radio-frequency laws require transmitter signals to “time-out” (or quit) after several seconds of transmission which may not be long enough for the integrated signal transmitter to pick up the signal during programming. Similar to this Canadian law, some U.S. gate operators are designed to “time-out” in the same manner.



### Useful features

If you live in Canada or if you are having difficulties programming a gate operator (regardless of where you live) by using the programming procedures, replace step 4 with the following:

Step 4:

- ▶ Press and hold the signal transmitter button (②, ③, or ④). Do not release this button until it has been successfully trained.
- ▶ While still holding down the signal transmitter button (②, ③ or ④), “cycle” your hand-held remote control button ⑥ as follows: Press and hold button ⑥ for 2 seconds, then release it for 2 seconds, and again press and hold it for 2 seconds. Repeat this sequence on the hand-held remote control until the frequency signal has been learned. Upon successful training, indicator lamp ① will flash slowly and then rapidly after several seconds.
- ▶ Proceed with programming step 5 and step 6 to complete.

**i** Upon completion of programming the integrated remote control, make sure you retain the hand-held remote control that came with the garage door opener, gate operator or other device. You may need it for use in other vehicles, for future programming of an integrated remote control, or simply for continued use as a hand-held remote control to operate the respective device in other situations.

### Reprogramming a single signal transmitter button

To program a device using a signal transmitter button previously trained, follow these steps:

- ▶ Switch on the ignition (▷ page 39).
- ▶ Press and hold the desired signal transmitter button (②, ③, or ④). Do not release the button.
- ▶ Indicator lamp ① will begin to flash after 20 seconds. Without releasing the signal transmitter button, proceed with programming starting with step 3.

### Operation of integrated remote control

- ▶ Switch on the ignition (▷ page 39).
- ▶ Select and press the appropriate signal transmitter button (②, ③, or ④) to activate the remote controlled device.

The integrated remote control transmitter continues to send the signal as long as the button is pressed – up to 20seconds.

### Erasing the integrated remote control memory

- ▶ Switch on the ignition (▷ page 39).
- ▶ Simultaneously press and hold outer signal transmitter buttons ② and ④, for approximately 20 seconds, until indicator lamp ① blinks rapidly. Do not hold for longer than 30 seconds.

The codes of all three channels are erased.

**i** If you sell your vehicle, erase the codes of all three channels.

## Programming tips

If you are having difficulty programming the integrated remote control, here are some helpful tips:

- Check the frequency of hand-held remote control ⑤ (typically located on the reverse side of the remote). The integrated remote control is compatible with radio-frequency devices operating between 280-390 MHz.
- Put a new battery in hand-held remote control ⑤. This will increase the likelihood of the hand-held remote control sending a faster and more accurate signal to the integrated remote control.
- While performing step 3, hold hand-held remote control ⑤ at different lengths and angles from the signal transmitter button (②, ③ or ④) you are programming. Attempt varying angles at the distance of 2 to 5 in (5 to 12 cm) away or the same angle at varying distances.
- If another hand-held remote control is available for the same device, try the programming steps again using that other hand-held remote control. Make sure new batteries are in the hand-held remote control before beginning the procedure.
- Straighten the antenna wire from the garage door opener assembly. This may help improve transmitting and/or receiving signals.

**i** *Certain types of garage door openers are incompatible with the integrated remote control. If you should experience further difficulties with programming the integrated remote control, contact an authorized Mercedes-Benz Light Truck Center, or call Mercedes-Benz Customer Assistance Center (in the USA only) at 1-800-FOR-MERCedes, or Customer Service (in Canada) at 1-800-387-0100.*

**i** *USA only:  
This device complies with Part 15 of the FCC Rules. Operation is subject to the following two conditions:*

- (1) *This device may not cause harmful interference, and*
- (2) *this device must accept any interference received, including interference that may cause undesired operation.*

*Any unauthorized modification to this device could void the user's authority to operate the equipment.*

**i** *Canada only:  
This device complies with RSS-210 of Industry Canada. Operation is subject to the following two conditions:*

- (1) *This device may not cause interference, and*
- (2) *this device must accept any interference received, including interference that may cause undesired operation of the device.*

*Any unauthorized modification to this device could void the user's authority to operate the equipment.*



**The first 1 000 miles (1 500 km)**

**Driving instructions**

**At the gas station**

**Engine compartment**

**Tires and wheels**

**Winter driving**

**Maintenance**

**Vehicle care**



### The first 1 000 miles (1 500 km)

In the “Operation” section you will find detailed information on operating, maintaining and caring for your vehicle.

The more cautiously you treat your vehicle during the break-in period, the more satisfied you will be with its performance later on.

- Drive your vehicle during the first 1 000 miles (1 500 km) at varying but moderate vehicle and engine speeds.
- During this period, avoid heavy loads (full throttle driving) and excessive engine speeds (no more than  $\frac{2}{3}$  of maximum rpm in each gear).
- Shift gears in a timely manner.
- Avoid accelerating by kick-down.
- Do not attempt to slow the vehicle down by shifting to a lower gear using the gear selector lever.
- Select gear ranges **3**, **2**, or **1** (▷ page 167) only when driving at moderate speeds (for hill driving).

After 1 000 miles (1 500 km) you may gradually increase vehicle and engine speeds to the permissible maximum.

**!** *Additional instructions for AMG vehicles:*

- *During the first 1 000 miles (1 500 km), do not exceed a speed of 85 mph (140 km/h).*
- *During this period, avoid engine speeds above 4 500 rpm in each gear.*

**i** *G 55 AMG:*

*For better protection of the front and rear differential, the oil must be changed after a break-in period of 1 900 miles (3 000 km).*

*Changing the oil in the front and rear differential increases the service life and helps reduce noise from the differential locks.*

*See Maintenance Booklet for additional information and Factory Approved Service Products pamphlet (USA only) for information on the approved service product required to perform the front and rear axle oil change.*

All of the above instructions, as may apply to your vehicle type, also apply when driving the first 1 000 miles (1 500 km) after the engine, the transfer case, the front differential or the rear differential has been replaced.

**i** *Always obey applicable speed limits.*

## ▼ Driving instructions

### Drive sensibly – save fuel

Fuel consumption, to a great extent, depends on driving habits and operating conditions.

To save fuel you should:

- Keep tires at the recommended inflation pressures.
- Remove unnecessary loads.
- Allow engine to warm up under low load use.
- Avoid frequent acceleration and deceleration.
- Have all maintenance work performed at the intervals specified in the Maintenance Booklet and as required by the Maintenance System. Contact an authorized Mercedes-Benz Light Truck Center.

Fuel consumption is also increased by driving in cold weather, in stop-and-go traffic, on short trips and in hilly area.

### Drinking and driving

#### Warning!



Drinking and driving and/or taking drugs and driving are very dangerous combinations. Even a small amount of alcohol or drugs can affect your reflexes, perceptions and judgment.

The possibility of a serious or even fatal accident are greatly increased when you drink or take drugs and drive.

Do not drink or take drugs and drive or allow anyone to drive who has been drinking or taking drugs.

### Pedals

#### Warning!



Make sure that absolutely no objects are obstructing the pedal's range of movement. Keep the driver's footwell clear of all obstacles. If there are any floor mats or carpets in the footwell, make sure that the pedals still have sufficient clearance.

During sudden driving or braking maneuvers, the objects could get caught between the pedals. You could then no longer brake or accelerate. This could lead to accidents and injury.

## Driving instructions

### Power assistance

#### Warning!



With the engine not running, there is no power assistance for the brake and steering systems. In this case, it is important to keep in mind that a considerably higher degree of effort is necessary to brake and steer the vehicle.

### Brakes

#### Warning!



After driving in heavy rain for some time without applying the brakes or through water deep enough to wet brake components or salty road conditions, the first braking action may be somewhat reduced and increased pedal pressure may be necessary to obtain expected braking effect. Maintain a safe distance from vehicles in front.

Resting your foot on the brake pedal will cause excessive and premature wear of the brake pads.

It can also result in the brakes overheating, thereby significantly reducing their effectiveness. It may not be possible to stop the vehicle in sufficient time to avoid an accident.

**!** *Operational or performance test must only be conducted on a two-axle dynamometer. If such tests are necessary, contact an authorized Mercedes-Benz Light Truck Center. You could otherwise seriously damage the brake system or the transfer case which is not covered by the Mercedes-Benz Limited Warranty.*

**!** *Because the ESP<sup>®</sup> operates automatically, the engine and ignition must be shut off (SmartKey in starter switch position **0** or **1**) when testing the parking brake on a brake test dynamometer and such testing should be no longer than 10 seconds.*

*Active braking action through the ESP<sup>®</sup> may otherwise seriously damage the brake system which is not covered by the Mercedes-Benz Limited Warranty.*

To help prevent brake disk corrosion after driving on wet road surfaces (particularly salted roads), it is advisable to brake the vehicle with considerable force prior to parking. The heat generated serves to dry the brakes.

If your brake system is normally only subjected to moderate loads, you should occasionally test the effectiveness of the brakes by applying above-normal braking pressure at higher speeds. This will also enhance the grip of the brake pads.

#### Warning!



Make sure not to endanger any other road users when carrying out these braking maneuvers.

Refer to the description of the Brake Assist System (BAS) (▷ page 90).

Brake pad wear or a leak in the system may be the reason for low brake fluid in the reservoir.

The brake fluid level in the reservoir may be too low if the brake warning lamp in the instrument cluster comes on although the parking brake is released (▷ page 326). Observe additional messages in the multifunction display that may appear (▷ page 338).

Have the brake system inspected immediately. Contact an authorized Mercedes-Benz Light Truck Center.

All checks and service work on the brake system should be carried out by qualified technicians only. Contact an authorized Mercedes-Benz Light Truck Center.

Only install brake pads and brake fluid recommended by Mercedes-Benz.

### Warning!



If other than recommended brake pads are installed, or other than recommended brake fluid is used, the braking properties of the vehicle can be degraded to an extent that safe braking is substantially impaired. This could result in an accident.

**!** *When driving down long and steep grades, relieve the load on the brakes by shifting into a lower gear to use the engine's braking power. This helps prevent overheating of the brakes and reduces brake pad wear.*

After hard braking, it is advisable to drive on for some time, rather than immediately park, so the air stream will cool down the brakes faster.

### Driving off

Apply the brakes to test them briefly after driving off. Perform this procedure only when the road is clear of other traffic.

Warm up the engine smoothly. Do not place full load on the engine until the operating temperature has been reached.

**!** *When driving off on a slippery surface, do not allow a drive wheel to spin for an extended period with the ESP<sup>®</sup> switched off. Doing so may cause serious damage to the drivetrain which is not covered by the Mercedes-Benz Limited Warranty.*

**!** *Simultaneously depressing the accelerator pedal and applying the brake reduces engine performance and causes premature brake and drivetrain wear.*

To ensure sufficient traction during off-road driving, activate differential locks as needed (▷ page 175).



## Driving instructions

### Parking

#### Warning!



Do not park this vehicle in areas where combustible materials such as grass, hay or leaves can come into contact with the hot exhaust system, as these materials could be ignited and cause a vehicle fire.

To reduce the risk of personal injury or damage to the vehicle drivetrain as a result of vehicle movement, before turning off the engine and leaving the vehicle always:

- Keep right foot on brake pedal.
- Pull the parking brake lever up as many notches as possible.
- Move the gear selector lever to park position **P**.
- Slowly release brake pedal.
- When parked on an incline, turn front wheel towards the road curb.
- Turn the SmartKey in the starter switch to position **0** and remove the SmartKey from the starter switch.
- Take the SmartKey with you and lock vehicle when leaving.

### Tires

#### Warning!



If you feel a sudden significant vibration or ride disturbance, or you suspect that possible damage to your vehicle has occurred, you should turn on the hazard warning flashers, carefully slow down, and drive with caution to an area which is a safe distance from the road.

Inspect the tires and the vehicle underbody for possible damage. If the vehicle or tires appear unsafe, have it towed to the nearest Mercedes-Benz Light Truck Center or tire dealer for repairs.

Treadwear indicators (TWI) are required by law. These indicators are located in six places on the tread circumference and become visible at a tread depth of approximately  $\frac{1}{16}$  in (1.6 mm), at which point the tire is considered worn and should be replaced.

The treadwear indicator appears as a solid band across the tread.

**Warning!**

Although the applicable federal motor vehicle safety laws consider a tire to be worn when the treadwear indicators (TWI) become visible at approximately  $\frac{1}{16}$  in (1.6 mm), we recommend that you do not allow your tires to wear down to that level. As tread depth approaches  $\frac{1}{8}$  in (3.0 mm), the adhesion properties on a wet road are sharply reduced.

Depending upon the weather and/or road surface (conditions), the tire traction varies widely.

Specified tire inflation pressures must be maintained. This applies particularly if the tires are subjected to high loads (e.g. high speeds, heavy loads, high ambient temperatures).

**Warning!**

Do not drive with a flat tire. A flat tire affects the ability to steer or brake the vehicle. You may lose control of the vehicle. Continued driving with a flat tire or driving at high speed with a flat tire will cause excessive heat build-up and possibly a fire.

For more information, see “Tires and wheels” (▷ page 277).

**Hydroplaning**

Depending on the depth of the water layer on the road, hydroplaning may occur, even at low speeds and with new tires. Reduce vehicle speed, avoid track grooves in the road and apply brakes cautiously in the rain.

**Tire traction**

The safe speed on a wet, snow covered or icy road is always lower than on a dry road.

You should pay particular attention to the condition of the road whenever the outside temperatures are close to the freezing point.

**Warning!**

If ice has formed on the road, tire traction will be substantially reduced. Under such weather conditions, drive, steer and brake with extreme caution.

### Driving instructions

Mercedes-Benz recommends winter tires (▷ page 309) with a minimum tread depth of approximately  $\frac{1}{6}$  in (4 mm) on all four wheels for the winter season to ensure normal balanced handling characteristics. On packed snow, they can reduce your stopping distance compared with summer tires.

Stopping distance, however, is still considerably greater than when the road is not covered with snow or ice. Exercise appropriate caution.

**!** *Avoid spinning of a drive wheel. This may cause serious damage to the drivetrain which is not covered by the Mercedes-Benz Limited Warranty.*

### Tire speed rating

Regardless of the tire speed rating, local speed limits should be obeyed. Use prudent driving speeds appropriate to prevailing conditions.

#### Warning!



Even when permitted by law, never operate a vehicle at speeds greater than the maximum speed rating of the tires.

Exceeding the maximum speed for which tires are rated can lead to sudden tire failure, causing loss of vehicle control and possibly resulting in an accident and/or serious injury and possible death, for you and for others.

Your vehicle is factory equipped with “V”-rated tires, which have a speed rating of 149 mph (240 km/h).

An electronic speed limiter prevents your vehicle from exceeding a speed of 130 mph (210 km/h).

**i** *For information on speed rating for winter tires, see “Winter tires” (▷ page 309).*

*For additional general information on tire speed markings on the tire sidewall, see “Tire speed rating” (▷ page 306).*

## Winter driving instructions

The most important rule for slippery or icy roads is to drive sensibly and to avoid abrupt acceleration, braking and steering maneuvers. Do not use the cruise control system under such conditions.

When the vehicle is in danger of skidding, move the gear selector lever to neutral position **N**. Try to keep the vehicle under control by corrective steering action.

 For information on driving with snow chains, see “Snow chains” (▷ page 310).

### Warning!



On slippery road surfaces, never downshift in order to obtain braking action. This could result in drive wheel slip and reduced vehicle control. Your vehicle’s ABS will not prevent this type of control loss.

Do not engage the transfer case in position **LOW** when driving on ice or packed snow. At speeds below 18 mph (30 km/h) vehicle steering is adversely affected by the **LOW RANGE – ABS** (▷ page 90).

Road salts and chemicals can adversely affect braking efficiency. Increased pedal force may become necessary to produce the normal brake effect.

Depressing the brake pedal periodically when traveling at length on salt-strewn roads can bring road-salt-impaired braking efficiency back to normal.

If the vehicle is parked after being driven on salt-treated roads, the braking efficiency should be tested as soon as possible after driving is resumed.

### Warning!



Make sure not to endanger any other road users when carrying out these braking maneuvers.

### Warning!



If the vehicle becomes stuck in snow, make sure that snow is kept clear of the exhaust pipe and from around the vehicle with the engine running. Otherwise, deadly carbon monoxide (CO) gases may enter vehicle interior resulting in unconsciousness and death.

To assure sufficient fresh air ventilation, open a window slightly on the side of the vehicle not facing the wind.

### Warning!



The outside temperature indicator is not designed to serve as an ice-warning device and is therefore unsuitable for that purpose. Indicated temperatures just above the freezing point do not guarantee that the road surface is free of ice.

For more information, see “Winter driving” (▷ page 309).

## Driving instructions

### Standing water

To prevent water from entering the passenger compartment or the engine compartment if you must drive through standing water, keep in mind

- the maximum depth of the water may not exceed 19 in (48 cm)
- you must drive slowly

**!** *Do not drive through flooded areas or water of unknown depth. Before driving through water, determine its depth. Never accelerate before driving into water. The bow wave could force water into the engine and auxiliary equipment, thus damaging them.*

*If you must drive through standing water, drive slowly to prevent water from entering the passenger compartment or the engine compartment.*

*Water in these areas could cause*

- *damage to electrical components*
- *wiring of the engine or transmission or could result*
- *in water being ingested by the engine through the air intake, causing severe internal engine damage.*

*Any such damage is not covered by the Mercedes-Benz Limited Warranty.*

For more information, see “Driving through water” (> page 257).

### Passenger compartment

#### Warning!



Always fasten items being carried as securely as possible.

In an accident, during hard braking or sudden maneuvers, loose items will be thrown around inside the vehicle, and cause injury to vehicle occupants unless the items are securely fastened in the vehicle.

The rear cargo compartment is the preferred place to carry objects. Always use cargo tie-down rings, and if so equipped, always use partition net\* when transporting cargo. The partition net\* cannot secure hard or heavy objects. Always fasten items being carried as securely as possible using the cargo tie-down rings in the cargo compartment floor and fastening materials.

Do not load items on the roof. It may cause instability during some maneuvers which could result in an accident. This vehicle is not intended to carry items on its roof. Thus roof rails and roof mounted ski or bike holders must not be used.

## Off-road driving

### Warning!



Do not load items on the roof. It may cause instability during some maneuvers which could result in an accident.

Drive slowly in unknown terrain. This will make it easier to recognize unexpected obstacles and avoid damage to the vehicle.

To help avoid the vehicle rolling over, never turn it around on steep inclines. If the vehicle cannot complete the attempted climb, back it down in reverse gear.

Do not drive along the side of a slope. The vehicle might otherwise rollover. If in doing so the vehicle begins to show a tendency to roll, immediately steer into a line of gravity (straight up or downhill).

Never let the vehicle roll backwards in idle. You may lose control of the vehicle if you use only the brake. For information on driving downhill, see “Driving downhill” (▷ page 257).

### Warning!



Sand, dirt, mud and other material having friction property can cause exceptional wear and tear as well as brake failure.

Have the brakes checked for dirt build-up and cleaned. There is otherwise a risk that full braking power may not be available in an emergency.

Read this chapter carefully before you begin off-road travel.

Familiarize yourself with the vehicle characteristics and gear changing before you attempt any difficult terrain off-road driving. We recommend that you start out with easy off-road travel.

## Special driving features for off-road driving

The following driving features are available for specific kind of operation:

- ABS (▷ page 88)
- ESP® (▷ page 92)
- 4-ETS (▷ page 91)
- Differential lock (▷ page 173)
- Transfer case (▷ page 170)

## Off-road driving rules

- ▶ Engage the transfer case in position **LOW** before driving under off-road conditions (▷ page 170).
- ▶ If necessary activate differential locks (▷ page 175).

The ABS, BAS and ESP® are switched off automatically when the differential locks are activated.

- ▶ Fasten items being carried as securely as possible (▷ page 208).

## Driving instructions

**!** Observe the following during off-road driving:

- Keep doors, tailgate, windows, and tilt/sliding sunroof closed.
- Switch cruise control off.
- Adjust vehicle speed to condition of terrain. The more uneven, rutty, and steeper the terrain, the lower the speed should be. Drive through water slowly at an even speed, avoiding a bow wave.
- Be especially careful when driving in unknown territory. It may be necessary to get out of the vehicle and scout the path you intend to take.
- Watch out for obstacles, such as rocks, holes, tree stumps, and ruts.
- Avoid excessive engine speeds – drive at moderate engine speeds (max. 3000 rpm).
- Before driving through water, determine its depth.
- Do not stop vehicle while immersed in water, and do not shut off the engine.

- In sandy soil, drive at a steady speed as allowed by conditions. This helps overcome the vehicle rolling resistance and reduces the likelihood of the vehicle sinking into the ground.
- Do not initiate jumps with the vehicle. It interrupts the forward momentum of the vehicle.
- Always drive on slopes with the engine running and the vehicle in gear.
- Inspect the vehicle for possible damage after each off-road trip.

### Warning!



Do not reduce the tire inflation pressure before driving through sand. However, if you do so, remember to correct the tire inflation pressure (▷ page 288) before continuing your trip. Driving with reduced tire inflation pressure increases the risk of losing control of the vehicle and rolling over.

## Checklist before off-road driving

### Engine oil level

- Check the engine oil level with the control system (▷ page 270). The message `Engine oil level OK` must appear in the multifunction display.

Only then can the vehicle obtain a trouble-free oil supply, even on steep gradients.

**!** If an engine oil level warning message (▷ page 351) appears in the multifunction display while driving, stop the vehicle in a safe location or as soon as it is safe to do so. Check the engine oil level (▷ page 270).

The engine oil level warning messages should not be ignored. Extended driving with the message displayed could result in serious engine damage that is not covered by the Mercedes-Benz Limited Warranty.

**Tires**

- Check the tread depth and maintain specified tire inflation pressure (the Tire and Loading Information placard with the recommended tire inflation pressures is located on the driver's door B-pillar (▷ page 280)).
- Check tires for possible damage and remove foreign objects.
- Replace missing valve caps.

**Rims**

- Dented or bent rims can cause tire inflation pressure loss and damage the tire beads. For this reason, check and, if necessary, change rims before driving off-road.

**Vehicle tool kit**

- Check if the vehicle jack (▷ page 367) is functional.
- In all cases take the vehicle tool kit, a strong tow rope, a shovel, and a small plank (to put under the vehicle jack on sandy soil) with you.

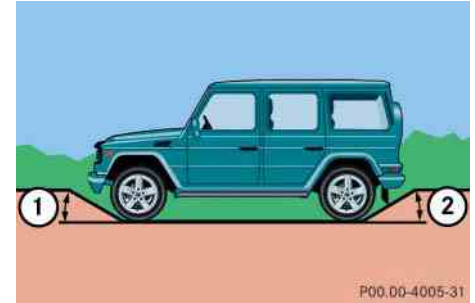
**Driving in steep terrain**

P00.00-4005-31

**Slope angle**

- ① Overhang angle, front, 37°
  - ② Overhang angle, rear, 31°
- Comply with the warnings (▷ page 253) and rules for off-road driving (▷ page 253).



### Driving instructions

- Driving on embankments, slopes and other steep inclines should only be done straight uphill or downhill, i.e. in the line of gravity. Maximum vehicle climbing ability is a 80% grade which is equivalent to a slope angle of approximately 38 degrees. Keep in mind that the climbing ability of the vehicle depends on terrain conditions.
- Select gear range **2** or **1** on the automatic transmission (▷ page 167).
- Drive slowly.
- Utilize the engine's braking power when descending a slope, observe the engine speed (do not overrev the engine). Apply the service brake as needed.

**i** For maximum engine speed, see "Instrument cluster" (▷ page 26) and see "Engine" (▷ page 415).

- Check the brakes after a lengthy downgrade drive.

#### Warning!



Never turn the vehicle around on steep inclines. The vehicle might roll over. If the vehicle cannot complete the attempted climb, back it down in reverse gear.

#### **Traction in steep terrain**

Be easy on the accelerator and watch for continuous wheel traction when driving uphill.

**i** The 4-ETS helps greatly when starting out on a steep incline when the front wheels have then the tendency to slip due to the weight shifting away from the front axle.

The 4-ETS recognizes the situation and limits the torque for the front wheels by braking them. Simultaneously the torque for the rear wheels is provided.

**Driving across a hilltop**

Decelerate just ahead of a hilltop (do not select gear range **N**), to prevent the vehicle from speeding up too much after climbing a hill.

Use the momentum of the vehicle to drive across the hilltop.

After climbing a hill, driving in this manner prevents the vehicle from:

- losing ground contact when cresting hills
- losing its forward momentum
- speeding up too much after climbing the hill

**Driving downhill**

- Select gear range **1** on the automatic transmission (▷ page 167).
- Drive downhill observing the same rules as driving uphill (▷ page 255).

**!** Only apply the service brake if the vehicle is travelling straight downhill, i.e. in the line of gravity.

**i** The special **LOW RANGE – ABS** setting allows for precise and brief (cyclical) blocking of the front wheels, permitting them to dig into loose ground.

Remember that, when stopped, the front wheels slide across a surface and thus lose their ability to steer the vehicle.

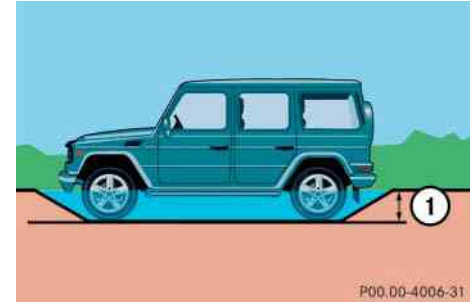
**Driving through water**

① Fording depth, 19.6 in (50 cm)

- Before driving through water, determine its depth.

**!** The water depth must not exceed 19.6 in (50 cm). The ground under the water might not be firm which could result in the water being deeper than expected when driving the vehicle through it. Please note that the water level is correspondingly lower for flowing water.

### Driving instructions

- Comply with the warnings (▷ page 253) and rules for off-road driving (▷ page 253).
- Switch off the exterior lamps as well as the climate control.
- Select gear range **2** or **1** on the automatic transmission (▷ page 167).
- Enter and leave the water only at a shallow spot, driving at walking speed.

**!** *Never accelerate before driving into the water. The bow wave could force water into the engine and auxiliary equipment, thus damaging them.*

- Drive through the water slowly and at a constant speed.

- Do not stop vehicle while immersed in water, and do not shut off the engine.

There is a very high level of driving resistance in water. The surface is slippery and may not be firm, making pulling away in water difficult and dangerous.

**!** *Do not open any of the vehicle's doors while driving through water. Water could otherwise enter the vehicle interior and damage the vehicle's electronics, as well as the interior equipment.*

- Make sure that only small bow waves are formed when driving the vehicle through water.
- Clean mud off the tire tread after driving through water.
- To dry the brakes, apply pressure to the brake pedal several times after leaving the water.

### Crossing obstacles



**!** *Obstacles can damage the vehicle underbody or suspension components. If possible, use the assistance of a second person outside the vehicle to scout the path you intend to take and check for adequate ground clearance when you cross obstacles with your vehicle. The person assisting you outside the vehicle should always be a safe distance away from the vehicle and positioned so that he or she cannot get hurt in case of any unexpected vehicle movement.*

*After off-road driving or crossing obstacles, inspect vehicle for any damage, especially vehicle underbody and suspension components. Failure to do so can adversely affect the vehicle's future performance, including increased chance of an accident.*

When driving over tree stumps, big rocks and other obstacles, observe the following rules:

- Check the vehicle clearance before crossing obstacles.
- Comply with the warnings (> page 253) and rules for off-road driving (> page 253).
- Select gear range **1** on the automatic transmission (> page 167).
- Cross obstacles very slowly by aiming one of the front wheels at the center of the obstacle, and repeat same with the rear wheel.

**!** *Special attention is needed when you cross obstacles on a steep incline.*

*The vehicle could slide sideways as a result of its possible slanted position which in turn may result in the vehicle tipping or rolling over.*

### Driving on sand

#### Warning!



Do not reduce the tire inflation pressure before driving through sand. However, if you do so, remember to correct the tire inflation pressure (> page 288) before continuing your trip. Driving with reduced tire inflation pressure increases the risk of losing control of the vehicle and rolling over.

When driving on sand, observe the following rules:

- Avoid high engine speeds.
- Shift automatic transmission into a gear range that is appropriate for the terrain.

- In sandy soil, drive at a steady speed as conditions permit. This helps overcome the vehicle rolling resistance and reduce the likelihood of the vehicle sinking into the ground.
- Drive in tracks of other vehicles if they are not too deep and you have sufficient clearance.

### Ruts

A number of off-road tracks or other byways have deep ruts which can cause the underbody to come in contact with the ground.

**!** *Check that the ruts are not too deep and your vehicle's clearance is sufficient. Otherwise:*

- *your vehicle may be damaged*
- *the underbody of the vehicle may come in contact with the ground and you may get stuck*

### Driving instructions

*After off-road driving or crossing obstacles, inspect vehicle for any damage, especially vehicle underbody and suspension components. Failure to do so can adversely affect the vehicle's future performance, including increased chance of an accident.*

- Check the vehicle clearance before driving in ruts.
- Comply with the warnings (▷ page 253) and rules for off-road driving (▷ page 253).
- Select gear range **1** on the automatic transmission (▷ page 167).
- Drive slowly next to the ruts rather than through them if at all possible.
- If the ruts are too deep to drive in, drive with one side of the vehicle on the grassy center strip if the route permits.

### Returning from off-road driving

#### Warning!



Never drive on pavement with activated differential locks. Engaged front axle differential locks limits ability to move around curves.

If you feel a sudden significant vibration or ride disturbance, or you suspect that possible damage to your vehicle has occurred, you should turn on the hazard warning flashers, carefully slow down, and drive with caution to an area which is a safe distance from the roadway.

Inspect the tires and under the vehicle for possible damage. If the vehicle or tires appear unsafe, have it towed to the nearest Mercedes-Benz Light Truck Center or tire dealer for repairs.

Damage to the vehicle may influence driving comfort and poses the risk of accident to you and other drivers.

Off-road driving increases strain on the vehicle.

We recommend that you inspect the vehicle for possible damage after each off-road trip. Recognizing any damage and a subsequent timely repair reduces the chance of a possible breakdown or accident later on.

Proceed as follows:

- Switch the transfer case in position **HIGH** (▷ page 170).
- Switch differential locks off (▷ page 176).
- Clean all exterior lamps and check them for possible damage.
- Clean the front and rear license plate.
- Remove excessive dirt from tires, wheels, wheel housings, and underbody.

For instance, after driving in mud, clean the radiator, chassis, engine, brakes, and wheels from extreme dirt using a strong jet of water.

- Check tires for possible damage.
- Inspect frame, oil pan, brake hoses, etc., as well as vehicle underbody for possible damage.
- Check for brush or branches caught in the underbody.

**!** *Brush or branches could increase the possibility of a fire, as well as cut fuel and/or brake lines, puncture rubber bellows of the axles or drive shafts.*

- After continued operation in mud, sand, water or other dirty conditions, clean the brake discs, wheels, brake pads, and check and clean axle joints.
- Conduct a brake test.

### Driving abroad

---

Abroad, there is an extensive Mercedes-Benz service network at your disposal. If you plan to drive into areas which are not listed in the index of a Mercedes-Benz Light Truck Center directory, you should request pertinent information from an authorized Mercedes-Benz Light Truck Center.

### Control and operation of radio transmitters

---

#### COMAND, radio and telephone\*

#### Warning!



Do not forget that your primary responsibility is to drive the vehicle safely. Only operate the COMAND system, radio or telephone<sup>1</sup> if road, weather and traffic conditions permit.

Bear in mind that at a speed of just 30 mph (approximately 50 km/h), your vehicle is covering a distance of 44 feet (approximately 14 m) every second.

<sup>1</sup> Observe all legal requirements.

### Driving instructions

#### Telephones and two-way radios

##### Warning!



Never operate radio transmitters equipped with a built-in or attached antenna (i.e. without being connected to an external antenna) from inside the vehicle while the engine is running. Doing so could lead to a malfunction of the vehicle's electronic system, possibly resulting in an accident and/or personal injury.

Radio transmitters, such as a portable telephone or citizens band unit should only be used inside the vehicle if they are connected to an antenna that is installed on the outside of the vehicle.

Refer to the radio transmitter operation instructions regarding use of an external antenna.

#### Catalytic converter

Your Mercedes-Benz is equipped with monolithic-type catalytic converters, an important element in conjunction with the oxygen sensors to achieve substantial control of the pollutants in the exhaust emissions. Keep your vehicle in proper operating condition by following our recommended maintenance instructions as outlined in your Maintenance Booklet.

**!** *To prevent damage to the catalytic converters, use only premium unleaded gasoline in this vehicle.*

*Any noticeable irregularities in engine operation should be repaired promptly. Otherwise, excessive unburned fuel may reach the catalytic converter, causing it to overheat and potentially start a fire.*

##### Warning!



As with any vehicle, do not idle, park or operate this vehicle in areas where combustible materials such as grass, hay or leaves can come into contact with the hot exhaust system, as these materials could be ignited and cause a vehicle fire.

## Emission control

---

Certain engine systems serve to keep the toxic components of the exhaust gases within permissible limits required by law.

These systems, of course, will function properly only when maintained strictly according to factory specifications. Any adjustments on the engine should, therefore, be carried out only by qualified Mercedes-Benz Light Truck Center authorized technicians.

Engine adjustments should not be altered in any way. Moreover, the specified service jobs must be carried out regularly according to Mercedes-Benz servicing requirements. For details refer to the Maintenance Booklet.

### Warning!



Inhalation of exhaust gas is hazardous to your health. All exhaust gas contains carbon monoxide (CO), and inhaling it can cause unconsciousness and possible death.

Do not run the engine in confined areas (such as a garage) which are not properly ventilated. If you think that exhaust gas fumes are entering the vehicle while driving, have the cause determined and corrected immediately. If you must drive under these conditions, drive only with at least one window fully open at all times.

## Coolant temperature

---

During severe operating conditions, e.g. stop-and-go traffic, the coolant temperature may rise close to approximately 248°F (120°C).

The engine should not be operated with the coolant temperature above 248°F (120°C). Doing so may cause serious engine damage which is not covered by the Mercedes-Benz Limited Warranty.

 *Excessive coolant temperatures trigger a warning message in the multifunction display (▷ page 348).*

### Warning!



- Driving when your engine is overheated can cause some fluids, which may have leaked into the engine compartment to catch fire. You could be seriously burned.
- Steam from an overheated engine can cause serious burns which can occur just by opening the hood. Stay away from the engine if you see or hear steam coming from it.

Turn off the engine, get out of the vehicle and do not stand near the vehicle until the engine has cooled down.



## At the gas station

### Refueling

#### Warning!



Gasoline is highly flammable and poisonous. It burns violently and can cause serious injury.

Never allow sparks, flame or smoking materials near gasoline!

Turn off the engine before refueling.

Whenever you are around gasoline, avoid inhaling fumes and skin or clothing contact, extinguish all smoking materials.

Direct skin contact with fuels and the inhalation of fuel vapors are damaging to your health.

The fuel filler flap is located on the right-hand side of the vehicle towards the rear.

Locking/unlocking the vehicle with the SmartKey automatically locks/unlocks the fuel filler flap.

**i** In case that the central locking system does not release the fuel filler flap, or the opening mechanism is clamping, you can open the fuel filler flap using an emergency release in the cargo compartment, see “Fuel filler flap” (▷ page 372).

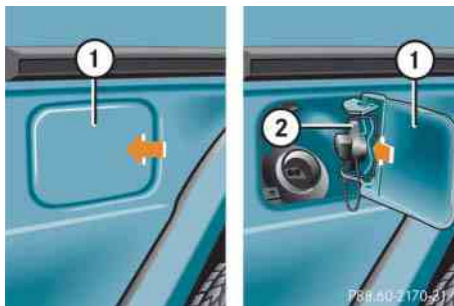

① Fuel filler flap

② Fuel filler cap

- ▶ Turn off the engine.
- ▶ Remove the SmartKey from the starter switch.
- ▶ Push on fuel filler flap ① at the position indicated by the arrow.  
Fuel filler flap ① springs open.
- ▶ Turn fuel filler cap ② to the left and hold on to it until possible pressure is released.
- ▶ Take off fuel filler cap ②.

**!** The fuel filler cap is tethered to the fuel filler neck. Do not drop the cap. It could damage the vehicle paint finish.

- ▶ Set fuel filler cap ② in the recess (indicated by the arrow) on fuel filler flap ①.
- ▶ To prevent fuel vapors from escaping into open air, fully insert filler nozzle unit.

- ▶ Only fill your tank until the filler nozzle unit cuts out – **do not top off or overfill.**

**Warning!**



Overfilling of the fuel tank may create pressure in the system which could cause a gas discharge. This could cause the gas to spray back out when removing the fuel pump nozzle, which could cause personal injury.

**!** When refueling the vehicle, make certain that no gasoline comes into contact with the rear side marker to prevent damaging the lens.

- ▶ Replace fuel filler cap ② by turning it clockwise until it audibly engages.

**i** Make sure to close the fuel filler flap before locking your vehicle as the flap locking pin prevents closing after you have locked the vehicle.

- ▶ Close fuel filler flap ①.

You should hear the latch close shut.

**i** Leaving the engine running and the fuel cap open can cause the **CHECK ENGINE** malfunction indicator lamp (USA only) or the  malfunction indicator lamp (Canada only) comes on.

For more information, see “Practical hints” (▷ page 328).

**i** Only use premium unleaded gasoline with a minimum Posted Octane Rating of 91 (average of 96 RON/86 MON). Information on gasoline quality can normally be found on the fuel pump.

Please contact gas station personnel in case labels on the pump cannot be found.

For more information on gasoline, see “Premium unleaded gasoline” (▷ page 426), refer to the Factory Approved Service Products pamphlet (USA only), or contact an authorized Mercedes-Benz Light Truck Center.

**Check regularly and before a long trip**

For information on quantities and requirements of operating agents, see “Fuels, coolants, lubricants, etc.” (▷ page 422).

- ▶ Open the hood (▷ page 267).



**G 500**

- ① Coolant
- ② Brake fluid

### At the gas station



#### G 55 AMG

- ① Coolant
- ② Brake fluid

#### Brake fluid

**!** If you find that the brake fluid in the brake fluid reservoir has fallen to the minimum mark or below, have the brake system checked for brake pad thickness and leaks immediately. Notify an authorized Mercedes-Benz Light Truck Center immediately. Do not add brake fluid as this will not solve the problem.

For more information, see “Practical hints” (▷ page 326) and see “Brake fluid” (▷ page 425).

#### Coolant

For normal replenishing, use water (potable water quality).

For more information, see “Coolant level” (▷ page 274) and see “Fuels, coolants, lubricants, etc.” (▷ page 422).

#### Engine oil level

For more information on engine oil, see “Engine oil” (▷ page 269).

#### Windshield/rear window washer system and headlamp cleaning system

For more information on refilling the washer reservoir, see “Windshield/rear window washer system and headlamp cleaning system” (▷ page 275).

#### Vehicle lighting

Check function and cleanliness.

For information on replacing light bulbs, see “Replacing bulbs” (▷ page 377).

For more information, see “Exterior lamp switch” (▷ page 117).

#### Tire inflation pressure

For more information, see “Checking tire inflation pressure” (▷ page 288).

## ▼ Engine compartment

### Hood

---

#### Warning!



Do not pull the release lever while the vehicle is in motion. Otherwise the hood could be forced open by passing air flow.

This could cause the hood to come loose and injure you and others.

### Opening

#### Warning!



If you see flames or smoke coming from the engine compartment, or if the coolant temperature display indicates that the engine is overheated, do not open the hood. Move away from vehicle and do not open the hood until the engine has cooled. If necessary, call the fire department.

#### Warning!



You could be injured when the hood is open – even when the engine is switched off.

Parts of the engine can become very hot. To prevent burns, let the engine cool off completely before touching any components on the vehicle. Comply with all relevant safety precautions.

#### Warning!



To help prevent personal injury, stay clear of moving parts when the hood is open and the engine is running.

The radiator fan may continue to run for approximately 30 seconds or even restart after the engine has been turned off. Stay clear of fan blades.

#### Warning!



The engine is equipped with a transistorized ignition system. Because of the high voltage, it is dangerous to touch any components (ignition coils, spark plug sockets, diagnostic socket) of the ignition system

- with the engine running
- while starting the engine
- if ignition is “on” and the engine is turned manually

## Engine compartment

The hood lock release lever is located to the left of the steering wheel under the dashboard.



① Hood lock release lever

**!** To avoid damage to the windshield wipers or hood, open the hood only with wipers in parked position.

- ▶ Pull release lever ① upward.  
The hood is unlocked.



**G 500**

② Safety hook

- ▶ Lift hood up slightly.
- ▶ Pull safety hook ② in direction of arrow.  
The hood is unlocked.
- ▶ Open the hood.



**G 55 AMG**

③ Safety hook

- ▶ Lift hood up slightly.
- ▶ Push safety hook ③ in direction of arrow.  
The hood is unlocked.
- ▶ Open the hood.

## Closing

### Warning!



When closing the hood, use extreme caution not to catch hands or fingers. Be careful that you do not close the hood on anyone.

Make sure that the hood is securely engaged before driving off. Do not continue driving if the hood can no longer engage after an accident, for example. The hood could otherwise come loose while the vehicle is in motion and endanger you and others.

- ▶ Lower hood and let it drop into lock from a height of approximately 0.7 ft (20 cm).

The hood will lock audibly.

- ▶ Check to make sure the hood is fully closed.

If you can raise the hood at a point above the turn signals to the left and right of the hood, then it is not properly closed. Open it again and let it drop with somewhat greater force.

**!** *Do not push the hood closed manually, as this could damage it.*

## Engine oil

The amount of oil your engine needs will depend on a number of factors, including driving style. Higher oil consumption can occur when

- the vehicle is new
- the vehicle is driven frequently at higher engine speeds

Engine oil consumption checks should only be made after the vehicle break-in period.

**!** *Do not use any special lubricant additives, as these may damage the drive assemblies. Using special additives not approved by Mercedes-Benz may cause damage not covered by the Mercedes-Benz Limited Warranty.*

*More information on this subject is available at any Mercedes-Benz Light Truck Center.*

## Engine compartment

### Checking engine oil level with the control system



When checking the oil level

- the vehicle must be parked on level ground
- with the engine at operating temperature, the vehicle must have been stationary for at least 5 minutes with the engine turned off
- with the engine not at operating temperature yet, the vehicle must have been stationary for at least 30 minutes with the engine turned off

To check the engine oil level via the multifunction display, do the following:

- ▶ Switch on the ignition (▷ page 39).

The standard display (▷ page 140) should appear in the multifunction display.

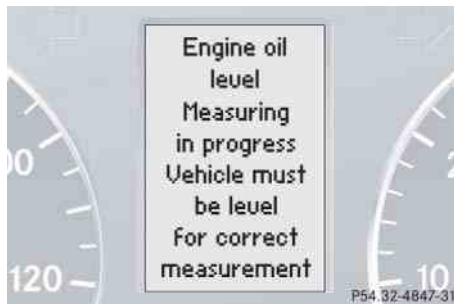

- ▶ Press button  or  on the multifunction steering wheel until the following message appears in the multifunction display:



One of the following messages will subsequently appear in the multifunction display:

- Engine oil level  
OK

- Add 1.0 qt to reach maximum oil level  
(Canada: 1.0 liter)
- Add 1.5 qts to reach maximum oil level  
(Canada: 1.5 liters)
- Add 2.0 qts to reach maximum oil level  
(Canada: 2.0 liters)

**i** If you want to interrupt the checking procedure, press button  or  on the multifunction steering wheel.

- ▶ If necessary, add engine oil (▷ page 273).

For more information on engine oil, see the “Technical data” section (▷ page 423) and (▷ page 425).

### Other display messages

If the SmartKey is not turned to position **2** in the starter switch, the following message will appear:

Switch  
ignition on to  
check engine  
oil level

- ▶ Switch on the ignition (▷ page 39).

If you see the message:

Observe  
waiting time

- ▶ If the engine is at operating temperature, wait 5 minutes before repeating check procedure.

- ▶ If the engine is not at operating temperature yet, wait 30 minutes before repeating check procedure.

If you see the message:

Engine oil  
level  
Not with  
engine on

- ▶ Turn off the engine.
- ▶ If the engine is at operating temperature, wait 5 minutes before checking oil.
- ▶ If the engine is not at operating temperature yet, you must wait 30 minutes before checking oil.

If there is excess engine oil with the engine at operating temperature, the following message will appear:

Engine oil  
level  
Reduce oil  
level

- ▶ Have excess oil siphoned or drained off. Contact an authorized Mercedes-Benz Light Truck Center.

**!** *Excess oil must be siphoned or drained off. It could cause damage to the engine and/or catalytic converter not covered by the Mercedes-Benz Limited Warranty.*

**i** *G 500 only:*

*Perform the engine oil level check with the oil dipstick if it cannot be completed with the control system (▷ page 272).*

*In this case we recommend that you have the system checked at a Mercedes-Benz Light Truck Center.*

For more information on messages in the multifunction display concerning engine oil, see the “Practical hints” section (▷ page 351).



## Engine compartment

### Checking engine oil level with the oil dipstick (G 500 only)

When checking the oil level

- the vehicle must be parked on level ground
  - with the engine at operating temperature, the vehicle must have been stationary for at least 5 minutes with the engine turned off
  - with the engine not at operating temperature yet, the vehicle also must have been stationary for at least 5 minutes with the engine turned off
- ▶ Open the hood (▷ page 267).

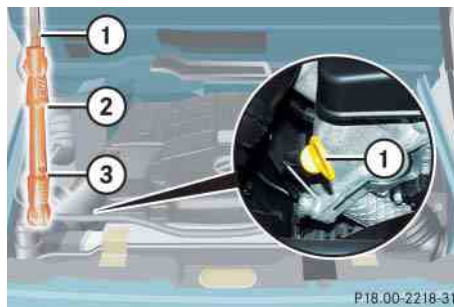

- ① Oil dipstick
- ② Upper mark
- ③ Lower mark

- ▶ Pull out oil dipstick ①.
- ▶ Wipe oil dipstick ① clean.
- ▶ Fully insert oil dipstick ① into the dipstick guide tube.

- ▶ Pull out oil dipstick ① again after approximately 3 seconds to obtain accurate reading.

The oil level is correct when it is between lower mark ③ (min.) and upper mark ② (max.) of the oil dipstick.

**i** The filling quantity between the upper and lower marks on the oil dipstick is approximately 2.1 US qt (2.0 l).

- ▶ If necessary, add engine oil (▷ page 273).

For more information on engine oil, see the “Technical data” section (▷ page 423) and (▷ page 425).

For more information on messages in the multifunction display concerning engine oil, see the “Practical hints” section (▷ page 351).

### Adding engine oil

**!** Only use approved engine oils and oil filters required for vehicles with Maintenance System (U.S. vehicles) or FSS (Canada vehicles). For a listing of approved engine oils and oil filters, refer to the Factory Approved Service Products pamphlet (USA only) in your vehicle literature portfolio, or contact an authorized Mercedes-Benz Light Truck Center.

Using engine oils and oil filters of specification other than those expressly required for the Maintenance System (U.S. vehicles) or FSS (Canada vehicles), or changing of oil and oil filter at change intervals longer than those called for by the Maintenance System (U.S. vehicles) or FSS (Canada vehicles) will result in engine or emission control system damage not covered by the Mercedes-Benz Limited Warranty.

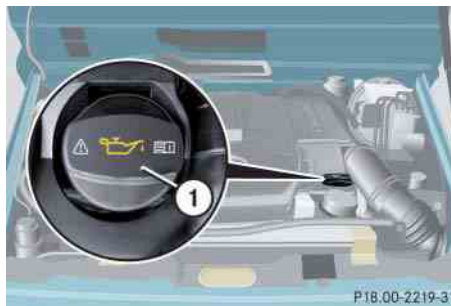

G 500

① Filler cap



G 55 AMG

① Filler cap

- ▶ Unscrew filler cap ① from filler neck.
- ▶ Add engine oil as required. Never over-fill with oil.

Be careful not to spill any oil when adding. Avoid environmental damage caused by oil entering the ground or water.

**!** Excess oil must be siphoned or drained off. It could cause damage to the engine and/or catalytic converter not covered by the Mercedes-Benz Limited Warranty.

- ▶ Screw filler cap ① back on filler neck.

For more information on engine oil, see the “Technical data” section (▷ page 423) and (▷ page 425).

### Transmission fluid level

The transmission fluid level does not need to be checked. If you notice transmission fluid loss or gear shifting malfunctions, have an authorized Mercedes-Benz Light Truck Center check the automatic transmission.

### Engine compartment

#### Coolant level

The engine coolant is a mixture of water and anticorrosion/antifreeze.

When checking the coolant level,

- the vehicle must be parked on level ground
- the coolant temperature must be below 158°F (70°C)

#### Warning!



In order to avoid any potentially serious burns:

- Use extreme caution when opening the hood if there are any signs of steam or coolant leaking from the cooling system, or if the coolant temperature display indicates that the coolant is overheated.
- Do not remove pressure cap on coolant reservoir if coolant temperature is above 158°F (70°C). Allow engine to cool down before removing cap. The coolant reservoir contains hot fluid and is under pressure.
- Using a rag, slowly open the cap approximately  $1/2$  turn to relieve excess pressure. If opened immediately, scalding hot fluid and steam will be blown out under pressure.
- Do not spill antifreeze on hot engine parts. Antifreeze contains ethylene glycol which may burn if it comes into contact with hot engine parts.

The coolant expansion tank is located on the passenger side of the engine compartment.



① Cap

- ▶ Using a rag, turn cap ① slowly approximately one half turn counterclockwise to release any excess pressure.
- ▶ Continue turning cap ① counterclockwise and remove it.

The coolant level is correct if the level

- for cold coolant: reaches the top of the mark (plastic bridge) visible through the filling opening
  - for warm coolant: is approximately 0.6 in (1.5 cm) higher
- ▶ Add coolant as required.
  - ▶ Replace cap ① on the filler neck.
  - ▶ Tighten cap ① clockwise until you hear it click three times.

For more information on coolant, see “Coolants” (▷ page 427).

### Windshield/rear window washer system and headlamp cleaning system

The windshield washer reservoir is located on the passenger side of the engine compartment.

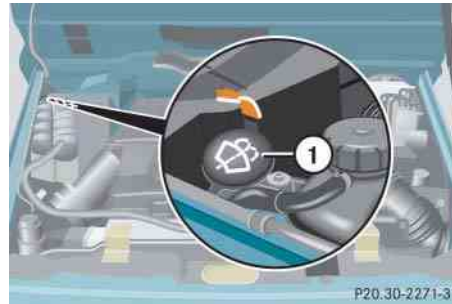

① Cap

Fluid for the windshield/rear window washer system and the headlamp cleaning system is supplied from the windshield washer reservoir. It has a capacity of 7.9 US qt (7.5 l).

During all seasons, add MB Windshield Washer Concentrate “MB SummerFit” to water. Premix the windshield washer fluid in a suitable container.

#### Warning!



Washer solvent/antifreeze is highly flammable. Do not spill washer solvent/antifreeze on hot engine parts, because it may ignite and burn. You could be seriously burned.

### Engine compartment

- ▶ Use the tab to pull cap ① upwards.
- ▶ Refill the reservoir with MB Windshield Washer Concentrate “MB SummerFit” and water (or commercially available premixed windshield washer solvent/antifreeze, depending on ambient temperatures).

**!** *Always use washer solvent/antifreeze where temperatures may fall below freezing point. Failure to do so could result in damage to the washer system/reservoir.*

**!** *Only use washer fluid which is suitable for plastic lenses. Improper washer fluid can damage the plastic lenses of the headlamps.*

- ▶ Press cap ① on the filler neck until it has completely engaged.

For more information on filling up the washer reservoir, see “Windshield/rear window washer system and headlamp cleaning system” (> page 430).

## ▼ Tires and wheels

Contact an authorized Mercedes-Benz Light Truck Center for information on tested and recommended rims and tires for summer and winter operation. They can also offer advice concerning tire service and purchase.

### Warning!



Replace rims or tires with the same designation, manufacturer and type as shown on the original part. See an authorized Mercedes-Benz Light Truck Center for further information. If incorrectly sized rims and tires are mounted:

- The wheel brakes or suspension components can be damaged.
- The operating clearance of the wheels and the tires may no longer be correct.

### Warning!



Worn, old tires can cause accidents. If the tire tread is badly worn, or if the tires have sustained damage, replace them.

When replacing rims, only use genuine Mercedes-Benz wheel bolts specified for the particular rim type. Failure to do so can result in the bolts loosening and possibly an accident.

Retreaded tires are not tested or recommended by Mercedes-Benz, since previous damage cannot always be recognized on retreads. The operating safety of the vehicle cannot be assured when such tires are used.

### Important guidelines

- Only use sets of tires and rims of the same type and make.
- Tires must be of the correct size for the rim.
- Break in new tires for approximately 60 miles (100 km) at moderate speeds.
- Regularly check the tires and rims for damage. Dented or bent rims can cause tire inflation pressure loss and damage to the tire beads.
- If vehicle is heavily loaded, check tire inflation pressure and correct as required.
- Do not allow your tires to wear down too far. Adhesion properties on wet roads are sharply reduced at tread depths of less than  $\frac{1}{8}$  in (3 mm).
- When replacing individual tires, you should mount new tires on the front wheels first (on vehicles with same-sized wheels all around).

## Tires and wheels

### Tire care and maintenance

#### Warning!



Regularly check the tires for damage. Damaged tires can cause tire inflation pressure loss. As a result, you could lose control of your vehicle.

Worn, old tires can cause accidents. If the tire tread is badly worn, or if the tires have sustained damage, replace them.

Regularly check your tire inflation pressure at least once a month. For more information on checking tire inflation pressure see “Recommended tire inflation pressure” (▷ page 286).

### Tire inspection

Every time you check your tire inflation pressure, you should also inspect your tires for the following:

- excessive treadwear (▷ page 279)
- cord or fabric showing through the tire’s rubber
- bumps, bulges, cuts, cracks or splits in the tread or side of the tire

Replace the tire if you find any of the above conditions.

Make sure you also inspect the spare tire periodically for condition and inflation. Spare tires will age and become worn over time even if never used, and thus should be inspected and replaced when necessary.

### Life of tire

The service life of a tire is dependent upon varying factors including but not limited to:

- Driving style
- Tire inflation pressure
- Distance driven

#### Warning!



Tires and spare tire should be replaced after 6 years, regardless of the remaining tread.

## Tread depth

Do not allow your tires to wear down too far. Adhesion properties on wet roads are sharply reduced at tread depths of less than  $\frac{1}{8}$  in (3 mm).

Treadwear indicators (TWI) are required by law. These indicators are located in six places on the tread circumference and become visible at a tread depth of approximately  $\frac{1}{16}$  in (1.6 mm), at which point the tire is considered worn and should be replaced.

Recommended minimum tire tread depth:

- Summer tires  $\frac{1}{8}$  in (3 mm)
- Winter tires  $\frac{1}{6}$  in (4 mm)

### Warning!



Although the applicable federal motor safety laws consider a tire to be worn when the treadwear indicators (TWI) become visible at approximately  $\frac{1}{16}$  in (1.6 mm), we recommend that you do not allow your tires to wear down to that level. As tread depth approaches  $\frac{1}{8}$  in (3 mm), the adhesion properties on a wet road are sharply reduced.

Depending upon the weather and/or road surface (conditions), the tire traction varies widely.

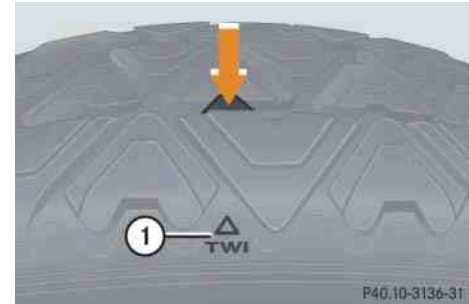

① TWI (Tread Wear Indicator)

The treadwear indicator appears as a solid band across the tread.

## Storing tires

**!** *Keep unmounted tires in a cool, dry place with as little exposure to light as possible. Protect tires from contact with oil, grease and gasoline.*

## Cleaning tires

**!** *Never use a round nozzle to power wash tires. The intense jet of water can result in damage to the tire.*

*Always replace a damaged tire.*



### Tires and wheels

#### Direction of rotation

Unidirectional tires offer added advantages, such as better hydroplaning performance. To benefit, however, you must make sure the tires rotate in the direction specified.

An arrow on the sidewall indicates the intended direction of rotation (spinning) of the tire.

**i** *Spare wheels may be mounted against the direction of rotation (spinning) even with a unidirectional tire for temporary use only until the regular drive wheel has been repaired or replaced. Always observe and follow applicable temporary use restrictions and speed limitations indicated on the spare wheel.*

#### Loading the vehicle

Two labels on your vehicle show how much weight it may properly carry.

- 1) The Tire and Loading Information placard can be found on the driver's door B-pillar. This placard tells you important information about the number of people that can be in the vehicle and the total weight that can be carried in the vehicle. It also contains information on the proper size and recommended tire inflation pressures for the original equipment tires on your vehicle.
- 2) The certification label, also found on the driver's door B-pillar tells you about the gross weight capacity of your vehicle, called the Gross Vehicle Weight Rating (GVWR). The GVWR includes the weight of the vehicle, all occupants, fuel and cargo. The certification label also tells you about the front and rear axle weight capacity, called the Gross Axle Weight Rating (GAWR). The GAWR

is the total allowable weight that can be carried by a single axle (front or rear). Never exceed the GVWR or GAWR for either the front axle or rear axle.

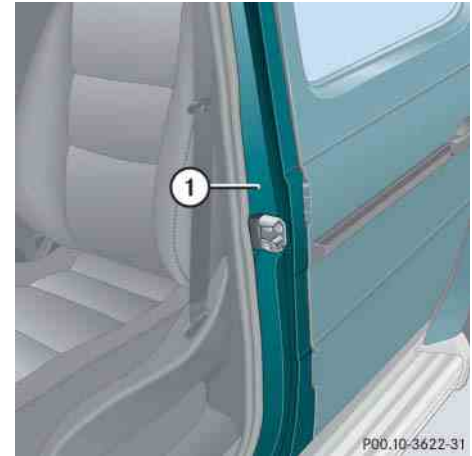

#### ① Driver's door B-pillar

Following is a discussion on how to work with the information contained on the Tire and Loading Information placard with regards to loading your vehicle.

### Tire and Loading Information

#### Warning!



Do not overload the tires by exceeding the specified load limit as indicated on the Tire and Loading Information placard on the driver's door B-pillar. Overloading the tires can overheat them, possibly causing a blowout. Overloading the tires can also result in handling or steering problems, or brake failure.

### Tire and Loading Information placard

**i** Data shown on Tire and Loading Information placard example are for illustration purposes only. Load limit data are specific to each vehicle and may vary from data shown in the illustration below. Refer to Tire and Loading Information placard on vehicle for actual data specific to your vehicle.

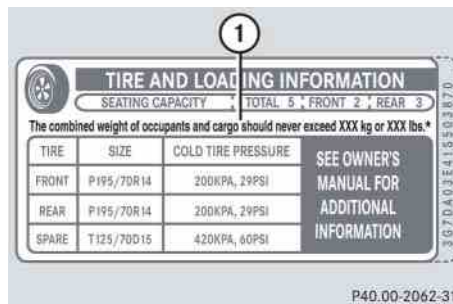

① Load limit information on the Tire and Loading Information placard

The Tire and Loading Information placard showing the load limit information is located on the driver's door B-pillar (▷ page 280).

- ▶ Locate the statement “The combined weight of occupants and cargo should never exceed XXX kilograms or XXX lbs.” on the Tire and Loading Information placard.

The combined weight of all occupants, cargo/luggage and trailer tongue load (if applicable) should never exceed the weight referenced in that statement.

## Tires and wheels

### Seating capacity

The seating capacity gives you important information on the number of occupants that can be in the vehicle. Observe front and rear seating capacity. The Tire and Loading Information placard showing the seating capacity is located on the driver's door B-pillar (▷ page 280).

**i** Data shown on Tire and Loading Information placard example are for illustration purposes only. Seating data are specific to each vehicle and may vary from data shown in the illustration below. Refer to Tire and Loading Information placard on vehicle for actual data specific to your vehicle.

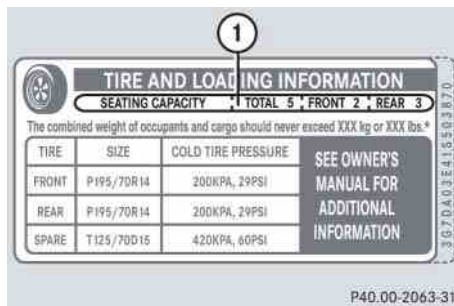

① Seating capacity information on the Tire and Loading Information placard

### Steps for determining correct load limit

The following steps have been developed as required of all manufacturers under Title 49, Code of U.S. Federal Regulations, Part 575 pursuant to the “National Traffic and Motor Vehicle Safety Act of 1966”.

#### Step 1

- ▶ Locate the statement “The combined weight of occupants and cargo should never exceed XXX kg or XXX lbs.” on your vehicle’s Tire and Loading Information placard.

#### Step 2

- ▶ Determine the combined weight of the driver and passengers that will be riding in your vehicle.

**Step 3**

- ▶ Subtract the combined weight of the driver and passengers from XXX kilograms or XXX lbs.

**Step 4**

- ▶ The resulting figure equals the available amount of cargo and luggage load capacity. For example, if the “XXX” amount equals 1400 lbs and there will be five 150 lbs passengers in your vehicle, the amount of available cargo and luggage load capacity is 650 lbs ( $1400 - 750 (5 \times 150) = 650$  lbs).

**Step 5**

- ▶ Determine the combined weight of luggage and cargo being loaded on the vehicle. That weight may not safely exceed the available cargo and luggage load capacity calculated in step 4.

**Step 6** (if applicable)

- ▶ If your vehicle will be towing a trailer, load from your trailer will be transferred to your vehicle. Consult this manual to determine how this reduces the available cargo and luggage load capacity of your vehicle (▷ page 285).

The following table shows examples on how to calculate total and cargo load capacities with varying seating configurations and number and size of occupants. The following examples use a load limit of 1500 lbs. **This is for illustration purposes only.** Make sure you are using the actual load limit for your vehicle stated on the vehicle’s Tire and Loading Information placard (▷ page 281).

## Tires and wheels

| Example | Combined weight limit of occupants and cargo from Tire and Loading Information placard | Number of occupants (driver and passengers) | Seating configuration | Occupants weight  | Combined weight of all occupants | Available cargo/luggage and trailer tongue weight (total load limit from Tire and Loading Information placard minus combined weight of all occupants) |
|---------|--|---|-----------------------|---|----------------------------------|---|
| 1       | 1500 lbs   | 5   | front: 2<br>rear: 3   | Occupant 1: 150 lbs<br>Occupant 2: 180 lbs<br>Occupant 3: 160 lbs<br>Occupant 4: 140 lbs<br>Occupant 5: 120 lbs | 750 lbs                          | 1500 lbs - 750 lbs = 750 lbs  |
| 2       | 1500 lbs   | 3   | front: 1<br>rear: 2   | Occupant 1: 200 lbs<br>Occupant 2: 190 lbs<br>Occupant 3: 150 lbs   | 540 lbs                          | 1500 lbs - 540 lbs = 960 lbs  |
| 3       | 1500 lbs   | 1   | front: 1              | Occupant 1: 150 lbs   | 150 lbs                          | 1500 lbs - 150 lbs = 1350 lbs   |

The higher the weight of all occupants, the less cargo and luggage load capacity is available.

For more information, see “Trailer tongue load” (> page 285).

***Certification label***

Even after careful determination of the combined weight of all occupants, cargo and the trailer tongue load (if applicable) (▷ page 285) as to not exceed the permissible load limit, you must make sure that your vehicle never exceeds the Gross Vehicle Weight Rating (GVWR) and the Gross Axle Weight Rating (GAWR) for either the front or rear axle. You can obtain the GVWR and GAWR from the certification label. The certification label can be found on the driver's door B-pillar, see "Technical data" (▷ page 412).

**Gross Vehicle Weight Rating (GVWR):**

The total weight of the vehicle, all occupants, all cargo, and the trailer tongue load (if applicable) (▷ page 285) must never exceed the GVWR.

**Gross Axle Weight Rating (GAWR):**

The total allowable weight that can be carried by a single axle (front or rear).

To assure that your vehicle does not exceed the maximum permissible weight limits (GVWR and GAWR for front and rear axle), have the loaded vehicle (including driver, passengers and all cargo and, if applicable, trailer fully loaded) weighed on a suitable commercial scale.

***Trailer tongue load***

The tongue load of any trailer is an important weight to measure because it affects the load you can carry in your vehicle. If a trailer is towed, the tongue load must be added to the weight of all occupants riding and any cargo you are carrying in the vehicle. The tongue load typically is 10 percent of the trailer weight and everything loaded in it.

If an approved Mercedes-Benz trailer hitch is available for your G-Class vehicle model, consult the instructions included in the trailer hitch kit for vehicle towing capacity, permissible gross trailer weight, trailer tongue weight rating, and instructions on loading and towing a trailer.

#### Recommended tire inflation pressure

##### Warning!



Follow recommended tire inflation pressures.

Do not underinflate tires. Underinflated tires wear excessively and/or unevenly, adversely affect handling and fuel economy, and are more likely to fail from being overheated.

Do not overinflate tires. Overinflated tires can adversely affect handling and ride comfort, wear unevenly, increase stopping distance, and result in sudden deflation (blowout) because they are more likely to become punctured or damaged by road debris, potholes etc.

Do not overload the tires by exceeding the specified load limit as indicated on the Tire and Loading Information placard on the driver's door B-pillar. Overloading the tires can overheat them, possibly causing a blowout. Overloading the tires can also result in handling or steering problems, or brake failure

Your vehicle is equipped with the Tire and Loading Information placard located on the driver's door B-pillar (▷ page 280).

The tire inflation pressure should be checked regularly and should only be adjusted on cold tires. The tires can be considered cold if the vehicle has been parked for at least 3 hours or driven less than 1 mile (1.6 km).

Follow recommended cold tire inflation pressures listed on the Tire and Loading Information placard on the driver's door B-pillar.

Keeping the tires properly inflated provides the best handling, tread life and riding comfort.

In addition to the Tire and Loading Information placard on the driver's door B-pillar, also consult the tire inflation pressure label (if available) on the inside of the fuel filler flap (▷ page 264) for any additional information pertaining to special driving situations. For more information, see "Important notes on tire inflation pressure" (▷ page 287).

**i** Data shown on Tire and Loading Information placard example are for illustration purposes only. Tire data are specific to each vehicle and may vary from data shown in the illustration below. Refer to Tire and Loading Information placard on vehicle for actual data specific to your vehicle.

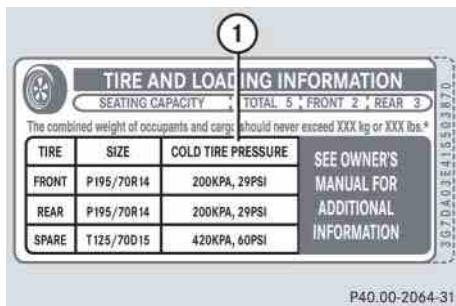

① Tire and Loading Information placard with recommended cold tire inflation pressures

The Tire and Loading Information placard lists the recommended cold tire inflation pressures for maximum loaded vehicle weight. The tire inflation pressures listed apply to the tires installed as original equipment.

### Important notes on tire inflation pressure

#### Warning!



If the tire inflation pressure drops repeatedly:

- Check the tires for punctures from foreign objects.
- Check to see whether air is leaking from the valves or from around the rim.

Tire temperature and tire inflation pressure are also increased while driving, depending on the driving speed and the tire load.

If you will be driving your vehicle at high speeds of 100 mph (160 km/h) or higher, where it is legal and conditions allow, consult the tire inflation pressure label on the inside of the fuel filler flap (if available) on how to adjust the cold tire inflation pressure. If you do not adjust the tire inflation pressure, excessive heat can build up and result in sudden tire failure.

If your vehicle is not equipped with the tire inflation pressure label on the inside of the fuel filler flap, contact an authorized Mercedes-Benz Light Truck Center for proper tire inflation pressure.

**i** Driving comfort may be reduced when the tire inflation pressure is adjusted to the value for speeds above 100 mph (160 km/h) as specified on the tire inflation pressure label (if available) located on the inside of the fuel filler flap.

Be sure to readjust the tire inflation pressure for normal driving speeds. You should wait until the tires are cold before adjusting the tire inflation pressure.

Some vehicles may have supplemental tire inflation pressure information for vehicle loads less than the maximum loaded vehicle condition. If such information is provided, it can be found on the tire inflation pressure label located on the inside of the fuel filler flap (▷ page 264).



### Tires and wheels

Tire inflation pressure changes by approximately 1.5 psi (0.1 bar) per 18°F (10°C) of air temperature change. Keep this in mind when checking tire inflation pressure where the temperature is different from the outside temperature.

#### Checking tire inflation pressure

Regularly check your tire inflation pressure at least once a month.

Check and adjust the tire inflation pressure when the tires are cold. The tires can be considered cold if the vehicle has been parked for at least 3 hours or driven less than 1 mile (1.6 km).

If you check the tire inflation pressure when the tires are warm (the vehicle has been driven for several miles or sitting less than 3 hours), the reading will be approximately 4 psi (0.3 bar) higher than the cold reading. This is normal. Do not let air out to match the specified cold tire inflation pressure. Otherwise, the tire will be underinflated.

#### Warning!



Follow recommended tire inflation pressures.

Do not underinflate tires. Underinflated tires wear excessively and/or unevenly, adversely affect handling and fuel economy, and are more likely to fail from being overheated.

Do not overinflate tires. Overinflated tires can adversely affect handling and ride comfort, wear unevenly, increase stopping distance, and result in sudden deflation (blowout) because they are more likely to become punctured or damaged by road debris, potholes etc.

Do not overload the tires by exceeding the specified load limit as indicated on the Tire and Loading Information placard on the driver's door B-pillar. Overloading the tires can overheat them, possibly causing a blowout. Overloading the tires can also result in handling or steering problems, or brake failure.

## Checking tire inflation pressure manually

Follow the steps below to achieve correct tire inflation pressure:

- ▶ Remove the cap from the valve on one tire.
- ▶ Firmly press a tire gauge onto the valve.
- ▶ Read tire inflation pressure on tire gauge and check against the recommended tire inflation pressure on the Tire and Loading Information placard on the driver's door B-pillar (▷ page 280). If necessary, add air to achieve the recommended tire inflation pressure.

**i** *If you have overfilled the tire, release tire inflation pressure by pushing the metal stem of the valve with e.g. a tip of a pen. Then recheck the tire inflation pressure with the tire gauge.*

- ▶ Install the valve cap.
- ▶ Repeat this procedure for each tire.

## Checking tire pressure electronically with the Advanced Tire Pressure Monitoring System (Advanced TPMS)

**i** *USA only:*

*The Tire Pressure Monitoring System (TPMS) is equipped with a combination low tire pressure/TPMS malfunction telltale in the instrument cluster (▷ page 26). Depending on how the telltale illuminates, it indicates a low tire pressure condition or a malfunction in the TPMS system itself:*

- *If the telltale illuminates continuously, one or more of your tires is significantly under-inflated. There is no malfunction in the TPMS.*
- *If the telltale flashes for 60 seconds and then stays illuminated, the TPMS system itself is not operating properly.*

**i** *USA only:*

*This device complies with Part 15 of the FCC Rules. Operation is subject to the following two conditions:*

- (1) *This device may not cause harmful interference, and*
- (2) *this device must accept any interference received, including interference that may cause undesired operation.*

*Any unauthorized modification to this device could void the user's authority to operate the equipment.*

**i** *Canada only:*

*This device complies with RSS-210 of Industry Canada. Operation is subject to the following two conditions:*

- (1) *This device may not cause interference, and*
- (2) *this device must accept any interference received, including interference that may cause undesired operation of the device.*



*Any unauthorized modification to this device could void the user's authority to operate the equipment.*

## Tires and wheels

The TPMS only functions on wheels that are equipped with the proper electronic sensors. It monitors the tire inflation pressure, as selected by the driver, in all four tires. A warning is issued to alert you to a decrease in pressure in one or more of the tires.

Tire pressure inquiries are made using the multifunction display. The present inflation pressures are displayed only after a few minutes travel time.

**i** Possible differences between the readings of a tire pressure gauge of an air hose, e.g. gas station equipment, and the vehicle's control system can occur. Usually the readings issued by the control system are more precise.

- ▶ Switch on the ignition (▷ page 39).
- ▶ Press button  or  until the current inflation pressures for each tire appear in the multifunction display.

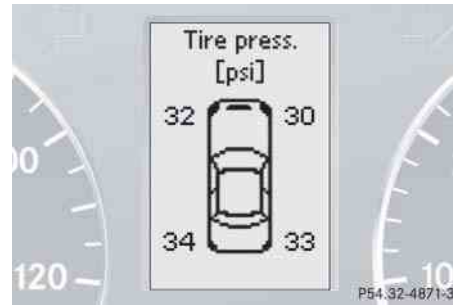

### Example illustration

**i** When the vehicle has been parked for longer than 20 minutes, the message **Tire pressure** displayed only after driving for a few minutes *appears in the multifunction display.*

### Warning!



It is the driver's responsibility to calibrate the TPMS on the recommended cold inflation pressure. Underinflated tires affect the ability to steer or brake the vehicle. You might lose control over the vehicle.

**i** With a spare wheel mounted, the system may still indicate the tire inflation pressure of the removed road wheel for some minutes. If this happens, keep in mind that the indicated value where the spare wheel is mounted does not reflect the actual spare tire inflation pressure.

**Warning!**

The Advanced TPMS does not indicate a warning for wrongly selected inflation pressures. Always adjust tire inflation pressure according to the Tire and Loading Information placard on the driver's door B-pillar or, if available, the supplemental tire inflation pressure information on the inside of the fuel filler flap.

The Advanced TPMS is not able to issue a warning due to a sudden dramatic loss of pressure (e.g. tire blowout caused by a foreign object). In this case bring the vehicle to a halt by carefully applying the brakes and avoiding abrupt steering maneuvers.

**Warning!**

Each tire, including the spare (if provided), should be checked monthly when cold and inflated to the inflation pressure recommended by the vehicle manufacturer on the Tire and Loading Information placard or the tire inflation pressure label (if available). If your vehicle has tires of a different size than the size indicated on the Tire and Loading Information placard or the tire inflation pressure label (if available), you should determine the proper tire inflation pressure for those tires.

As an added safety feature, your vehicle has been equipped with an Advanced Tire Pressure Monitoring System (Advanced TPMS) that illuminates a low tire pressure telltale when one or more of your tires is significantly underinflated. Accordingly, when the low tire pressure telltale illuminates, you should stop and check your tires as soon as possible, and inflate them to the proper pressure.

Driving on a significantly underinflated tire causes the tire to overheat and can lead to tire failure.

Underinflation also reduces fuel efficiency and tire tread life, and may affect the vehicle's handling and stopping ability. Please note that the Advanced TPMS is not a substitute for proper tire maintenance, and it is the driver's responsibility to maintain correct tire pressure, even if underinflation has not reached the level to trigger illumination of the Advanced TPMS low tire pressure telltale.

USA only: Your vehicle has also been equipped with a Advanced TPMS malfunction indicator to indicate when the system is not operating properly. The Advanced TPMS malfunction indicator is combined with the low tire pressure telltale. When the system detects a malfunction, the telltale will flash for approximately 1 minute and then remain continuously illuminated. This sequence will continue upon subsequent vehicle start-ups as long as the malfunction exists.



### Tires and wheels

▷▷ USA only: When the malfunction indicator is illuminated, the system may not be able to detect or signal low tire pressure as intended.

USA only: Advanced TPMS malfunctions may occur for a variety of reasons, including the installation of replacement or alternate tires or wheels on the vehicle that prevent the Advanced TPMS from functioning properly. Always check the Advanced TPMS malfunction telltale after replacing one or more tires or wheels on your vehicle to ensure that the replacement or alternate tires and wheels allow the Advanced TPMS to continue to function properly.

**i** *Operating radio transmission equipment (e.g. wireless headsets, two-way radios) in or near the vehicle could cause the Advanced TPMS to malfunction.*

#### **Tire inflation pressure warnings**

If the system detects a significant loss of tire inflation pressure in one or more than one tire, a message appears in the multi-function display.



#### **Example illustration**

The respective tire is indicated by a red rectangle. In addition, a warning signal sounds.

#### **Restarting Advanced TPMS**

The TPMS usually recognizes new reference values automatically, for example when you have

- adjusted the tire inflation pressure
- changed wheels or tires
- mounted new wheels or tires

#### **Warning!**







It is the driver's responsibility to calibrate the TPMS on the recommended cold inflation pressure. Underinflated tires affect the ability to steer or brake the vehicle. You might lose control over the vehicle.

If you want to set new reference values manually:

- ▶ Using the Tire and Loading Information placard on the driver's door B-pillar (▷ page 280) or, if available, the supplemental tire inflation pressure information on the inside of the fuel filler flap (▷ page 264), make sure the tire inflation pressure of all four tires is correct.

**i** Restart the TPMS after adjusting the tire inflation pressure to the inflation pressure recommended for the vehicle operating condition. Tire pressure should only be adjusted on cold tires. Observe the recommended tire inflation pressure on the Tire and Loading Information placard on the driver's door B-pillar (▷ page 280). Some vehicles may have supplemental tire inflation pressure information for driving at high speeds (▷ page 287) or for vehicle loads less than the maximum loaded vehicle condition (▷ page 287). If such information is provided, it can be found on the inside of the fuel filler flap (▷ page 264).

- ▶ Press button  or  on the multifunction steering wheel repeatedly until the standard display menu appears in the multifunction display.
- ▶ Press button  or  repeatedly until you see the current inflation pressures for each tire appear in the multifunction display or the following message appears in the multifunction display:  
Tire pressure  
displayed  
only after  
driving for  
a few minutes

- ▶ Press the reset button (▷ page 130).

The following message will appear in the multifunction display:

Restart  
tire pressure  
monitor?

- ▶ Press the  button.

The following message will appear in the multifunction display:

Tire pressure  
monitor  
restarted

After driving a few minutes the system verifies that the current tire inflation pressures are within the system's specified range. Afterwards the current tire inflation pressures are accepted as reference pressures and then monitored.

If you wish to cancel activation:

- ▶ Press the  button.

## Tires and wheels

### Potential problems associated with underinflated and overinflated tires

#### *Underinflated tires*

Underinflated tires can:

- cause excessive and uneven tire wear
- adversely affect fuel economy
- lead to tire failure from being overheated
- adversely affect handling characteristics

#### **Warning!**



Follow recommended tire inflation pressures.

Do not underinflate tires. Underinflated tires wear excessively and/or unevenly, adversely affect handling and fuel economy, and are more likely to fail from being overheated.

#### *Overinflated tires*

Overinflated tires can:

- adversely affect handling characteristics
- cause uneven tire wear
- be more prone to damage from road hazards
- adversely affect ride comfort
- increase stopping distance

#### **Warning!**



Follow recommended tire inflation pressures.

Do not overinflate tires. Overinflated tires can adversely affect handling and ride comfort, wear unevenly, increase stopping distance, and result in sudden deflation (blowout) because they are more likely to become punctured or damaged by road debris, potholes etc.

### Tire labeling

Besides tire name (sales designation) and manufacturer name, a number of markings can be found on a tire.

Following are some explanations for the markings on your vehicle's tires:

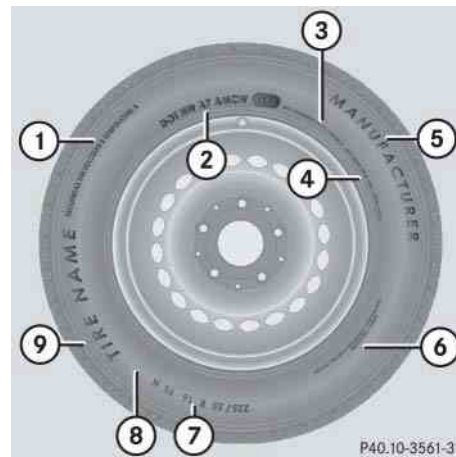

- ① Uniform Quality Grading Standards  
(▷ page 302)
- ② DOT, Tire Identification Number (TIN)  
(▷ page 299)
- ③ Maximum tire load (▷ page 300)
- ④ Maximum tire inflation pressure  
(▷ page 301)
- ⑤ Manufacturer
- ⑥ Tire ply material (▷ page 304)
- ⑦ Tire size designation, load and speed rating (▷ page 295)
- ⑧ Load identification (▷ page 298)
- ⑨ Tire name

**i** For illustration purposes only. Actual data on tires are specific to each vehicle and may vary from data shown in above illustration.

For more information, see “Rims and tires”  
(▷ page 416).

### Tire size designation, load and speed rating

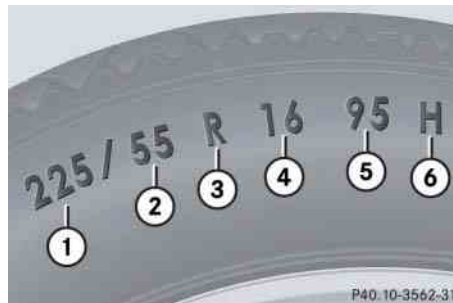

- ① Tire width
- ② Aspect ratio in %
- ③ Radial tire code
- ④ Rim diameter
- ⑤ Tire load rating
- ⑥ Tire speed rating

**i** For illustration purposes only. Actual data on tires are specific to each vehicle and may vary from data shown in above illustration.

General:

Depending on the design standards used, the tire size molded into the sidewall may have no letter or a letter preceding the tire size designation.

No letter preceding the size designation (as illustrated above): Passenger car tire based on European design standards.

Letter “P” preceding the size designation: Passenger car tire based on U.S. design standards.

Letter “LT” preceding the size designation: Light Truck tire based on U.S. design standards.

Letter “T” preceding the size designation: Temporary spare tires which are high pressure compact spares designed for temporary emergency use only.



### Tires and wheels

#### *Tire width*

The tire width ① (▷ page 295) indicates the nominal tire width in mm.

#### *Aspect ratio*

The aspect ratio ② (▷ page 295) is the dimensional relationship between tire section height and section width and is expressed in percentage. The aspect ratio is arrived at by dividing section height by section width.

#### *Tire code*

The tire code ③ (▷ page 295) indicates the tire construction type. The “R” stands for radial tire type. Letter “D” means diagonal or bias ply construction; letter “B” means belted-bias ply construction.

At the tire manufacturer’s option, any tire with a speed capability above 149 mph (240 km/h) can include a “ZR” in the size designation (for example: 245/40 ZR 18). For additional information, see “Tire speed rating” (▷ page 297).

#### *Rim diameter*

The rim diameter ④ (▷ page 295) is the diameter of the bead seat, not the diameter of the rim edge. Rim diameter is indicated in inches (in).

#### *Tire load rating*

The tire load rating ⑤ (▷ page 295) is a numerical code associated with the maximum load a tire can support.

For example, a load rating of 91 corresponds to a maximum load of 1356 lbs (615 kg) the tire is designed to support. See also “Maximum tire load” (▷ page 300) where the maximum load associated with the load index is indicated in kilograms and lbs.

#### **Warning!**



The tire load rating must always be at least half of the GAWR (▷ page 305) of your vehicle. Otherwise, tire failure may be the result which may cause an accident and/or serious personal injury to you or others.

Always replace rims and tires with the same designation, manufacturer and type as shown on the original part.

#### **Warning!**



Do not overload the tires by exceeding the specified load limit as indicated on the Tire and Loading Information placard located on the driver’s door B-pillar. Overloading the tires can overheat them, possibly causing a blowout. Overloading the tires can also result in handling or steering problems, or brake failure.

For additional information on tire load rating, see “Load identification” (▷ page 298).

**i** Tire load rating ⑤ (▷ page 295) and tire speed rating ⑥ (▷ page 295) are also referred to as “service description”.

### Tire speed rating

The tire speed rating ⑥ (▷ page 295) indicates the approved maximum speed for the tire.

#### Warning!



Even when permitted by law, never operate a vehicle at speeds greater than the maximum speed rating of the tires.

Exceeding the maximum speed for which tires are rated can lead to sudden tire failure, causing loss of vehicle control and possibly resulting in an accident and/or personal injury and possible death, for you and for others.

**i** Tire load rating ⑤ (▷ page 295) and tire speed rating ⑥ (▷ page 295) are also referred to as “service description”.

### Summer tires

| Index | Speed rating             |
|-------|--------------------------|
| Q     | up to 100 mph (160 km/h) |
| R     | up to 106 mph (170 km/h) |
| S     | up to 112 mph (180 km/h) |
| T     | up to 118 mph (190 km/h) |
| H     | up to 130 mph (210 km/h) |
| V     | up to 149 mph (240 km/h) |
| W     | up to 168 mph (270 km/h) |
| Y     | up to 186 mph (300 km/h) |
| (Y)   | above 186 mph (300 km/h) |
| ZR    | above 149 mph (240 km/h) |

- At the tire manufacturer’s option, any tire with a speed capability above 149 mph (240 km/h) can include a “ZR” in the size designation (for example: 245/40 ZR18). To determine the maximum speed capability of the tire, the service description for the tire must be referred to. The service description is comprised of the tire load rating ⑤ (▷ page 295) and the tire speed rating ⑥ (▷ page 295).

If your tire includes “ZR” in the size designation and no service description ⑤ and ⑥ (▷ page 295) is given, the tire manufacturer must be consulted for the maximum speed capability.

## Tires and wheels

If a service description ⑤ and ⑥ (▷ page 295) is given, the speed capability is limited by the speed symbol in the service description.

Example: 245/40 ZR18 97Y.

In this example, “97Y” is the service description. The letter “Y” designates the speed rating and the speed capability of the tire is limited to 186 mph (300 km/h).

- Any tire with a speed capability above 186 mph (300 km/h) must include a “ZR” in the size designation AND the service description must be placed in parenthesis. Example: 275/40 ZR18 (99Y). The “(Y)” speed rating in parenthesis designates the maximum speed capability of the tire as being above 186 mph (300 km/h). Consult the tire manufacturer for the actual maximum permissible speed of the tire.

All-season and winter tires

| Index              | Speed rating             |
|--------------------|--------------------------|
| Q M+S <sup>1</sup> | up to 100 mph (160 km/h) |
| T M+S <sup>1</sup> | up to 118 mph (190 km/h) |
| H M+S <sup>1</sup> | up to 130 mph (210 km/h) |
| V M+S <sup>1</sup> | up to 149 mph (240 km/h) |

<sup>1</sup> or M+S  for winter tires

**i** Not all M+S rated tires provide special winter performance. Make sure the tires you use show M+S and the mountain/snowflake marking  on the tire sidewall. These tires meet specific snow traction performance requirements of the Rubber Manufacturers Association (RMA) and the Rubber Association of Canada (RAC) and have been designed specifically for use in snow conditions.

## Load identification



### ① Load identification

**i** For illustration purposes only. Actual data on tires are specific to each vehicle and may vary from data shown in above illustration.

In addition to tire load rating, special load identification ① may be molded into the tire sidewall following the letter designating the tire speed rating (▷ page 295).

No specification given: absence of any text (like in above example) indicates a standard load (SL) tire.

XL or Extra Load: designates an extra load (or reinforced) tire.

Light Load: designates a light load tire.

C, D, E: designates load range associated with the maximum load a tire can carry at a specified pressure.

### DOT, Tire Identification Number (TIN)

U.S. tire regulations require each new tire manufacturer or tire retreader to mold a TIN into or onto a sidewall of each tire produced.

The TIN is a unique identifier which facilitates efforts by tire manufacturers to notify purchasers in recall situations or other safety matters concerning tires and gives purchasers the means to easily identify such tires.

The TIN is comprised of “Manufacturer’s identification mark”, “Tire size”, “Tire type code” and “Date of manufacture”.

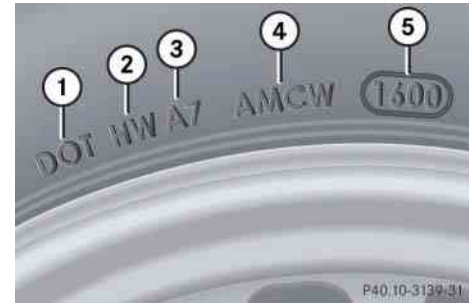

- ① DOT
- ② Manufacturer’s identification mark
- ③ Tire size
- ④ Tire type code (at the option of the tire manufacturer)
- ⑤ Date of manufacture

**i** For illustration purposes only. Actual data on tires are specific to each vehicle and may vary from data shown in above illustration.

## Tires and wheels

### DOT (Department of Transportation)

A tire branding symbol ① (▷ page 299) which denotes the tire meets requirements of the U.S. Department of Transportation.

### Manufacturer's identification mark

The manufacturer's identification mark ② (▷ page 299) denotes the tire manufacturer.

New tires have a mark with two symbols.

Retreaded tires have a mark with four symbols. For more information on retreaded tires (▷ page 277).

### Tire size

The code ③ (▷ page 299) indicates the tire size.

### Tire type code

The code ④ (▷ page 299) may, at the option of the manufacturer, be used as a descriptive code for identifying significant characteristics of the tire.

### Date of manufacture

The date of manufacture ⑤ (▷ page 299) identifies the week and year of manufacture.

The first two figures identify the week, starting with "01" to represent the first full week of the calendar year. The second two figures represent the year.

For example, "3202" represents the 32nd week of 2002.

### Maximum tire load



#### ① Maximum tire load rating

**i** For illustration purposes only. Actual data on tires are specific to each vehicle and may vary from data shown in above illustration.

The maximum tire load is the maximum weight the tires are designed to support.

**Warning!**

Do not overload the tires by exceeding the specified load limit as indicated on the Tire and Loading Information placard located on the driver's door B-pillar. Overloading the tires can overheat them, possibly causing a blowout. Overloading the tires can also result in handling or steering problems, or brake failure.

For more information on tire load rating (▷ page 296).

For information on calculating total and cargo load capacities (▷ page 282).

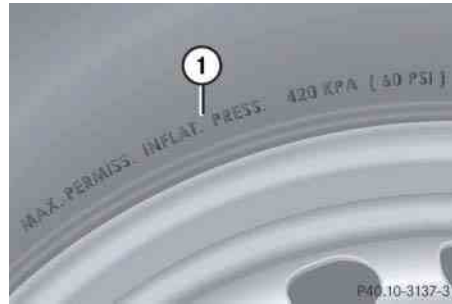
**Maximum tire inflation pressure**

① Maximum permissible tire inflation pressure

**i** *For illustration purposes only. Actual data on tires are specific to each vehicle and may vary from data shown in above illustration.*

This is the maximum permissible tire inflation pressure for the tire.

Always follow the recommended tire inflation pressure (▷ page 286) for proper tire inflation.

**Warning!**

Never exceed the max. tire inflation pressure. Follow recommended tire inflation pressures.

Do not underinflate tires. Underinflated tires wear excessively and/or unevenly, adversely affect handling and fuel economy, and are more likely to fail from being overheated.

Do not overinflate tires. Overinflated tires can adversely affect handling and ride comfort, wear unevenly, increase stopping distance, and result in sudden deflation (blowout) because they are more likely to become punctured or damaged by road debris, potholes etc.

## Tires and wheels

### Uniform Tire Quality Grading Standards (U.S. vehicles)

Tire manufacturers are required to grade tires based on three performance factors: treadwear, traction and temperature resistance.

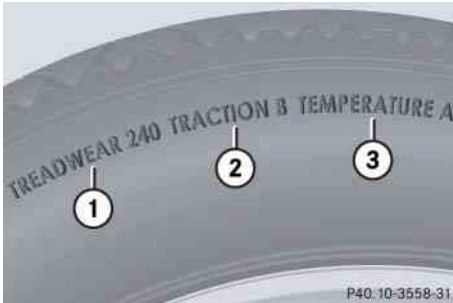

- ① Treadwear
- ② Traction
- ③ Temperature resistance

**i** For illustration purposes only. Actual data on tires are specific to each vehicle and may vary from data shown in above illustration.

Quality grades can be found, where applicable, on the tire sidewall between tread shoulder and maximum section width. For example:

| Treadwear | Traction | Temperature |
|-----------|----------|-------------|
| 200       | AA       | A           |

All passenger car tires must conform to federal safety requirements in addition to these grades.

### Treadwear

The treadwear grade is a comparative rating based on the wear rate of the tire when tested under controlled conditions on a specified government test course. For example, a tire graded 150 would wear one and one-half ( $1\frac{1}{2}$ ) times as well on the government course as a tire graded 100. The relative performance of tires depends upon the actual conditions of their use, however, and may depart significantly from the norm due to variations in driving habits, service practices and differences in road characteristics and climate.

## Traction

The traction grades, from highest to lowest, are AA, A, B, and C. Those grades represent the tire's ability to stop on wet pavement as measured under controlled conditions on specified government test surfaces of asphalt and concrete. A tire marked C may have poor traction performance.

### Warning!



The traction grade assigned to this tire is based on straight-ahead braking traction tests, and does not include acceleration, cornering, hydroplaning, or peak traction characteristics.

## Temperature

The temperature grades are A (the highest), B, and C, representing the tire's resistance to the generation of heat and its ability to dissipate heat when tested under controlled conditions on a specified indoor laboratory test wheel. Sustained high temperature can cause the material of the tire to degenerate and reduce tire life, and excessive temperature can lead to sudden tire failure. The grade C corresponds to a level of performance which all passenger car tires must meet under the Federal Motor Vehicle Safety Standard No. 109. Grades B and A represent higher levels of performance on the laboratory test wheel than the minimum required by law.

### Warning!



The temperature grade for this tire is established for a tire that is properly inflated and not overloaded. Excessive speed, underinflation, or excessive loading, either separately or in combination, can cause excessive heat build-up and possible tire failure.



## Tires and wheels

### Tire ply material

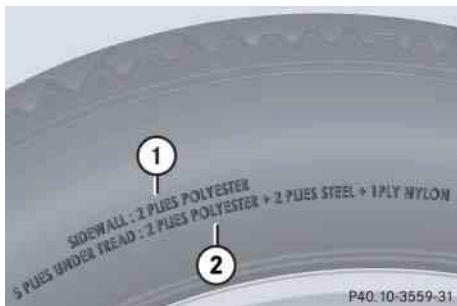

- ① Plies in sidewall
- ② Plies under tread

**i** For illustration purposes only. Actual data on tires are specific to each vehicle and may vary from data shown in above illustration.

This marking tells you about the type of cord and number of plies in the sidewall and under the tread.

### Tire and loading terminology

#### Accessory weight

The combined weight (in excess of those standard items which may be replaced) of automatic transmission, power steering, power brakes, power windows, power seats, radio, and heater, to the extent that these items are available as factory-installed equipment (whether installed or not).

#### Air pressure

The amount of air inside the tire pressing outward on each square inch of the tire. Air pressure is expressed in pounds per square inch (psi), or kilopascal (kPa) or bars.

#### Aspect ratio

Dimensional relationship between tire section height and section width expressed in percentage.

#### Bar

Another metric unit for air pressure. There are 14.5038 pounds per square inch (psi) to 1 bar; there are 100 kilopascals (kPa) to 1 bar.

#### Bead

The tire bead contains steel wires wrapped by steel cords that hold the tire onto the rim.

#### Cold tire inflation pressure

Tire inflation pressure when your vehicle has been sitting for at least 3 hours or driven no more than 1 mile (1.6 km).

#### Curb weight

The weight of a motor vehicle with standard equipment including the maximum capacity of fuel, oil, and coolant, and, if so equipped, air conditioning and additional optional equipment, but without passengers and cargo.

**DOT (Department of Transportation)**

A tire branding symbol which denotes the tire meets requirements of the U.S. Department of Transportation.

**GAWR (Gross Axle Weight Rating)**

The GAWR is the maximum permissible axle weight. The gross vehicle weight on each axle must never exceed the GAWR for the front and rear axle indicated on the certification label located on the driver's door B-pillar.

**GTW (Gross Trailer Weight)**

The GTW is the weight of the trailer plus the weight of all cargo, equipment, luggage etc. loaded on the trailer.

**GVW (Gross Vehicle Weight)**

The GVW comprises the weight of the vehicle including fuel, tools, spare wheel, installed accessories, passengers and cargo and, if applicable, trailer tongue load. The GVW must never exceed the GVWR indicated on the certification label located on the driver's door B-pillar.

**GVWR (Gross Vehicle Weight Rating)**

This is the maximum permissible vehicle weight of the fully loaded vehicle (weight of the vehicle including all options, passengers, fuel, and cargo and, if applicable, trailer tongue load). It is indicated on certification label located on the driver's door B-pillar.

**Kilopascal (kPa)**

The metric unit for air pressure. There are 6.9 kPa to 1 psi; another metric unit for air pressure is bars. There are 100 kilopascals (kPa) to 1 bar.

**Maximum load rating**

The maximum load in kilograms and pounds that can be carried by the tire.

**Maximum loaded vehicle weight**

The sum of curb weight, accessory weight, total load limit, and production options weight.

**Maximum tire inflation pressure**

This number is the greatest amount of air pressure that should ever be put in the tire under normal driving conditions.

**Normal occupant weight**

The number of occupants the vehicle is designed to seat, multiplied by 68 kilograms (150 lbs).

**Occupant distribution**

The distribution of occupants in a vehicle at their designated seating positions.

### Tires and wheels

#### Production options weight

The combined weight of those installed regular production options weighing over 5 lbs (2.3 kilograms) in excess of those standard items which they replace, not previously considered in curb weight or accessory weight, including heavy duty brakes, ride levelers, heavy duty battery, and special trim.

#### PSI (Pounds per square inch)

A standard unit of measure for air pressure -> bar, kilopascal (kPa).

#### Recommended tire inflation pressure

Recommended tire inflation pressure for normal driving conditions is listed on the Tire and Loading Information placard located on the driver's door B-pillar. Provides best handling, tread life and riding comfort. If so equipped, supplemental information pertaining to special driving situations can be found on the tire inflation pressure label on the inside of the fuel filler flap.

#### Rim

A metal support for a tire or a tire and tube assembly upon which the tire beads are seated.

#### Sidewall

The portion of a tire between the tread and the bead.

#### TIN (Tire Identification Number)

Unique identifier which facilitates efforts by tire manufacturers to notify purchasers in recall situations or other safety matters concerning tires and gives purchases the means to easily identify such tires. The TIN is comprised of "Manufacturer's identification mark", "Tire size", "Tire type code" and "Date of manufacture".

#### Tire load rating

Numerical code associated with the maximum load a tire can support.

#### Tire ply composition and material used

This indicates the number of plies or the number of layers of rubber-coated fabric in the tire tread and sidewall. Tire manufacturers also must indicate the ply materials in the tire and sidewall, which include steel, nylon, polyester, and others.

#### Tire speed rating

Part of tire designation; indicates the speed range for which a tire is approved.

#### Total load limit

Rated cargo and luggage load plus 68 kilograms (150 lbs) times the vehicle's designated seating capacity.

### Traction

Force exerted by the vehicle on the road via the tires. The amount of grip provided.

### Tread

The portion of a tire that comes into contact with the road.

### Treadwear indicators

Narrow bands, sometimes called “wear bars” that show across the tread of a tire when only  $\frac{1}{16}$  in (1.6 mm) of tread remains.

### TWR (Tongue Weight Rating)

Maximum permissible weight on trailer tongue.

### Uniform Tire Quality Grading Standards

A tire information system that provides consumers with ratings for a tire’s traction, temperature and treadwear. Ratings are determined by tire manufacturers using government testing procedures. The ratings are molded into the sidewall of the tire.

### Vehicle maximum load on the tire

Load on an individual tire that is determined by distributing to each axle its share of the maximum loaded vehicle weight and dividing it by two.

### Rotating tires

#### Warning!



Rotate front and rear wheels only if the tires are of the same dimension.

If your vehicle is equipped with mixed-size tires (different tire dimensions front vs. rear), tire rotation is not possible.

Tire rotation can be performed on vehicles with tires of the same dimension all around. If your vehicle is equipped with tires of the same dimension all around, tires can be rotated, observing a front-to-rear rotation pattern that will maintain the intended rotation (spinning) direction of the tire (▷ page 280).

In some cases, such as when your vehicle is equipped with mixed-size tires (different tire dimension front vs. rear), tire rotation is not possible.

### Tires and wheels

If applicable to your vehicle's tire configuration, tires can be rotated according to the tire manufacturer's recommended intervals in the tire manufacturer's warranty pamphlet located in your vehicle literature portfolio. If none is available, tires should be rotated every 3000 to 6000 miles (5000 to 10000 km), or sooner if necessary, according to the degree of tire wear. The same rotation (spinning) direction must be maintained (▷ page 280).

Rotate tires before the characteristic tire wear pattern becomes visible (shoulder wear on front tires and tread center wear on rear tires).

Thoroughly clean the mounting face of wheels and brake disks, i.e. the inner side of the wheels/tires, during each rotation. Check for and ensure proper tire inflation pressure.

#### Warning!



Have the tightening torque checked after changing a wheel. Wheels could become loose if not tightened with a torque of 97 lb-ft (130 Nm).

Only use genuine Mercedes-Benz wheel bolts specified for your vehicle's rims.

For information on wheel change, see the "Practical hints" section (▷ page 366) and (▷ page 390).

## ▼ Winter driving

Before the onset of winter, have your vehicle winterized at an authorized Mercedes-Benz Light Truck Center. This service includes:

- Check of anticorrosion and antifreeze concentration.
- Addition of cleaning concentrate to the water of the windshield and headlamp cleaning system. Add MB Concentrate “MB SummerFit” to a premixed windshield washer solvent/antifreeze which is formulated for below freezing temperatures (> page 430).
- Battery test. Battery capacity drops with decreasing ambient temperature. A well charged battery helps to make sure that the engine can be started, even at low ambient temperatures.
- Tire change. Mercedes-Benz recommends M+S rated radial-ply tires with a minimum tread depth of approximately  $\frac{1}{6}$  in (4 mm) on all four wheels for the winter season.

## Winter tires

Always use winter tires at temperatures below 45°F (7°C) and whenever wintry road conditions prevail. Not all M+S rated tires provide special winter performance. Make sure the tires you use show M+S and the mountain/snowflake marking  on the tire sidewall. These tires meet specific snow traction performance requirements of the Rubber Manufacturers Association (RMA) and the Rubber Association of Canada (RAC) and have been designed specifically for use in snow conditions. Using winter tires is the only way to achieve the maximum effectiveness of the ABS, ESP® and 4-ETS in winter operation.

For safe handling, make sure all mounted winter tires are of the same make and have the same tread design.

### Warning!



Winter tires with a tread depth of less than  $\frac{1}{6}$  in (4 mm) must be replaced. They are no longer suitable for winter operation.

Always observe the speed rating of the winter tires installed on your vehicle. If the maximum speed for which your tires are rated is below the speed rating of your vehicle, you must place a notice to this effect where it will be seen by the driver. Such notices are available from your tire dealer or from any authorized Mercedes-Benz Light Truck Center.

#### Warning!



If you use your spare tire when winter tires are fitted on the other wheels, be aware that the difference in tire characteristics may very well impair turning stability and that overall driving stability may be reduced. Adapt your driving style accordingly.

Have the spare tire replaced with a winter tire at the nearest authorized Mercedes-Benz Light Truck Center.

#### Block heater (Canada only)

The engine is equipped with a block heater.

The electrical cable may be installed at an authorized Mercedes-Benz Light Truck Center.

#### Snow chains

Snow chains should only be driven on snow-covered roads at speeds not to exceed 30 mph (50 km/h). Remove chains as soon as possible when driving on roads without snow.

**i** *When driving with snow chains, you may wish to deactivate the ESP® (▷ page 92) before setting the vehicle in motion. This will improve the vehicle's traction.*

Please observe the following guidelines when using snow chains:

- Use of snow chains is not permissible with all wheel/tire combinations (▷ page 417).
- Snow chains should only be used on the rear wheels. Follow the manufacturer's mounting instructions.
- Only use snow chains that are approved by Mercedes-Benz. Any authorized Mercedes-Benz Light Truck Center will be glad to advise you on this subject.
- Use of snow chains may be prohibited depending on location. Always check local and state laws before installing snow chains.

## ▼ Maintenance

We strongly recommend that you have your vehicle serviced at an authorized Mercedes-Benz Light Truck Center, in accordance with the Maintenance Booklet at the times called for by the maintenance service indicator.

**!** *Failure to have the vehicle maintained in accordance with the Maintenance Booklet and maintenance service indicator at the designated times/mileage may result in vehicle damage not covered by the Mercedes-Benz Limited Warranty.*

### Maintenance service indicator message



The maintenance service indicator message will notify you when the next maintenance service is due.

Starting approximately 1 month before the next maintenance service is due, one of the following messages will appear in the multifunction display while you are driving or when you switch on the ignition (example service A):

Service A in XX Days  
 Service A in XX miles (km)  
 Service A due now



The type of maintenance service due is indicated in the multifunction display:

-  Basic service (A)
-  Extended service (B)



**i** Vehicles equipped with Maintenance System (U.S. vehicles) only:

The Maintenance System in your vehicle tracks distance driven and the time elapsed since the last maintenance service and calculates other maintenance service work required.

**i** Vehicles equipped with FSS (Flexible Service System) (Canada vehicles) only:

- FSS evaluates engine temperature, oil level, vehicle speed, engine speed, distance driven and the time elapsed since the last maintenance service and calculates other maintenance service work required.
- The interval between maintenance services depends on your driving habits. A gentle driving style, moderate engine speeds and the avoidance of short-distance trips will lengthen the interval between services.

### Clearing the maintenance service indicator message

The maintenance service indicator message is automatically cleared

- after approximately 10 seconds when you switch on the ignition or when reaching the maintenance service threshold while driving
- after approximately 30 seconds, once the suggested maintenance service term has passed

You can also clear maintenance service indicator message yourself.



① Reset button

- ▶ Press reset button ① on the instrument cluster.

The maintenance service indicator message is cleared and the standard display appears in the multifunction display (▷ page 140).

### Maintenance service term exceeded

If you have exceeded the suggested maintenance service term, you will see the following message in the multifunction display:

Service A exceeded by XX Days

Service A exceeded by XX miles (km)



In addition, a signal sounds when the message appears.





Any authorized Mercedes-Benz Light Truck Center will reset the maintenance service indicator following a completed maintenance service.

### Calling up the maintenance service indicator display

You can call up the maintenance service indicator display at any time to check when the next maintenance service is due.

- ▶ Switch on the ignition (▷ page 39).

- ▶ Press button  or  on the multifunction steering wheel repeatedly until the standard display appears in the multifunction display (▷ page 140).

- ▶ Press button  or  on the multifunction steering wheel until the maintenance service indicator display with the maintenance service symbol  or  and the service deadline appears in the multifunction display.

**i** *If the battery is disconnected, the days of disconnection will not be included in the count shown by the maintenance service indicator. To arrive at the true maintenance service deadline, you will need to subtract these days from the days shown in the maintenance service indicator message or maintenance service indicator display.*

*Do not confuse the maintenance service indicator with the engine oil level indicator .*

### Resetting the maintenance service indicator

In the event that the maintenance service on your vehicle is not carried out at an authorized Mercedes-Benz Light Truck Center, you can have the maintenance service indicator reset. The automotive maintenance facility carrying out the maintenance service will find the information for resetting the maintenance service indicator in the maintenance-relevant information for your vehicle. Such information is available from any authorized Mercedes-Benz Light Truck Center or directly from Mercedes-Benz.

**!** *If the maintenance service indicator was inadvertently reset, have an authorized Mercedes-Benz Light Truck Center correct it.*

*Only reset if the proper maintenance service has been performed. Resetting the system without performing the proper maintenance service as called for by the maintenance service indicator will result in engine damage and/or other vehicle damage not covered by the Mercedes-Benz Limited Warranty.*

### Cleaning and care of the vehicle

Regular and proper care will help to maintain the value of your vehicle. The best way to protect your vehicle from harmful environmental influences is to wash it and use protective treatments regularly.

#### Warning!



Many cleaning products can be hazardous. Some are poisonous, others are flammable. Always follow the instructions on the particular container. Always open your vehicle's doors or windows when cleaning the inside.

Never use fluids or solvents that are not designed for cleaning your vehicle.

Always lock away cleaning products and keep them out of reach of children.

While in operation, even while parked, your vehicle is subjected to varying external influences which, if gone unchecked, can attack the paintwork as well as the underbody and cause lasting damage.

Such damage is caused not only by extreme and varying climatic conditions, but also by:

- Air pollution
- Road salt
- Tar
- Gravel and stone chipping

To avoid paint damage, you should immediately remove:

- Grease and oil
- Fuel
- Coolant
- Brake fluid
- Bird droppings
- Insects
- Tree resins, etc.

Frequent washing reduces and/or eliminates the aggressiveness and potency of the above adverse influences.

More frequent washings are necessary to deal with unfavorable conditions:

- near the ocean
- in industrial areas (smoke, exhaust emissions)
- during winter operation

You should check your vehicle from time to time for stone chipping or other damage. Any damage should be repaired as soon as possible to prevent corrosion.

In doing so, do not neglect the underbody of the vehicle. A prerequisite for a thorough check is a washing of the underbody followed by a thorough inspection. Damaged areas need to be re-undercoated.

Your vehicle has been treated at the factory with a wax-base rustproofing in the body cavities which will last for the lifetime of the vehicle. Post-production treatment is neither necessary nor recommended by Mercedes-Benz because of the possibility of incompatibility between materials used in the production process and others applied later.

We have selected car-care products and compiled recommendations which are specially matched to our vehicles and which always reflect the latest technology. You can obtain Mercedes-Benz approved car-care products at an authorized Mercedes-Benz Light Truck Center.

Scratches, corrosive deposits, corrosion or damage due to negligent or incorrect care cannot always be removed or repaired with the car-care products recommended here. In such cases it is best to seek aid at an authorized Mercedes-Benz Light Truck Center.

The following topics deal with the cleaning and care of your vehicle and give important “how-to” information as well as references to Mercedes-Benz approved car-care products.

### Power washer

**!** *Follow the instructions provided by the power washer manufacturer on maintaining a distance between the vehicle and the nozzle of the power washer.*

*Never use a round nozzle to power-wash tires. The intense jet of water can result in damage to the tire.*

*Always replace a damaged tire.*

*Always keep the jet of water moving across the surface. Do not aim directly at electrical parts, electrical connectors, sensors, seals, or other rubber parts.*

### Tar stains

Quickly remove tar stains before they dry and become more difficult to remove. A tar remover is recommended.

#### Paintwork, painted body components

! *Affixing stickers, adhesive tape or similar materials to painted body components may damage the paintwork.*

Mercedes-Benz approved Paint Care should be applied when water drops on the paint surface do not “bead up”. This should normally be done every 3 to 5 months, depending on the climate and washing detergent used.

Mercedes-Benz approved Paint Cleaner should be applied if the paint surface shows signs of dirt embedding (i.e. loss of gloss).

Do not apply any of these products or wax if your vehicle is parked in the sun or if the hood is still hot.

- ▶ Use the appropriate MB-Touch-Up Stick for quick and provisional repairs of minor paint damage (i.e. chips from stones, vehicle doors, etc.).

#### Engine cleaning

Prior to cleaning the engine compartment, make sure to protect electrical components and connectors from the intrusion of water and cleaning agents.

Corrosion protection, such as MB Anticorrosion Wax, should be applied to the engine compartment after every engine cleaning. Before applying, all control linkage bushings and joints should be lubricated. The poly-V-belt and all pulleys should be protected from any wax.

#### Vehicle washing

In the winter, thoroughly remove all traces of road salt as soon as possible.

When washing the vehicle underbody, do not forget to clean the inner sides of the wheels.

#### **Hand-wash**

Do not use hot water or wash your vehicle in direct sunlight.

- ▶ Only use a mild car wash detergent, such as Mercedes-Benz approved Car Shampoo.
- ▶ Thoroughly spray the vehicle with a diffused jet of water.  
  
Direct only a very weak spray towards the ventilation intake.
- ▶ Use plenty of water and rinse the sponge and chamois frequently.

- ▶ Rinse with clean water and thoroughly dry with a chamois.

Do not allow cleaning agents to dry on the finish.

**!** Do not use scouring agents on these parts.

*Never apply strong force and only use a soft, non-scratching cloth when cleaning the vehicle. Do not attempt to wipe the surface with a dry cloth or sponge.*

*Otherwise you may scratch or damage the paint.*

### **Automatic car wash**

You can have your car washed in an automatic car wash from the start. Automatic car washes without brushes are preferable.

- ▶ To protect the filter system, switch the climate control to air recirculation mode (▷ page 183).

**!** Do not clean your vehicle in an automatic touchless car wash which use caustic spray. Otherwise the caustic spray will damage the paint or ornamental moldings.

If the vehicle is very dirty, prewash it before running it through the automatic car wash.

**!** Make sure that the windshield wiper switch is set to **0** (▷ page 58). Otherwise, e.g. the rain sensor could activate and cause the wipers to move unintentionally. This may lead to vehicle damage.

*Due to the width of the vehicle, fold in exterior rear view mirrors prior to running the vehicle through an automatic car wash to prevent damage to the mirrors.*

**i** After running the vehicle through an automatic car wash, wipe any wax off of the windshield (▷ page 319). This will prevent smears and reduce wiping noise which can be caused by residual wax on the windshield.

*When leaving the car wash, make sure that the mirrors are folded out. Otherwise they may vibrate.*

### **Ornamental moldings**

For regular cleaning and care of ornamental moldings, use a damp cloth.

**!** Do not use chrome cleaner on ornamental moldings. Although ornamental moldings may have chrome appearance, they could be made of anodized aluminum that will be damaged when cleaned with chrome cleaner. Instead, use a damp cloth to clean those ornamental moldings.

*For very dirty ornamental moldings of which you are sure are chrome-plated, use a chrome cleaner. If in doubt whether an ornamental molding is chrome-plated, contact an authorized Mercedes-Benz Light Truck Center.*

### Vehicle care

#### Headlamps, brake lamps, tail lamps, side markers, turn signal lenses

- ▶ Use a mild car wash detergent, such as Mercedes-Benz approved Car Shampoo, with plenty of water.

**!** Only use window cleaning solutions that are suitable for plastic lamp lenses. Window cleaning solutions which are not suitable may damage the plastic lamp lenses of the headlamps. Therefore, do not use abrasives, solvents or cleaners that contain solvents.

Never apply strong force and only use a soft, non-scratching cloth when cleaning the lenses. Do not attempt to wipe dirty lenses with a dry cloth or sponge.

Otherwise you may scratch or damage the lens surface.

#### Cleaning the Rear Parking Assist sensors

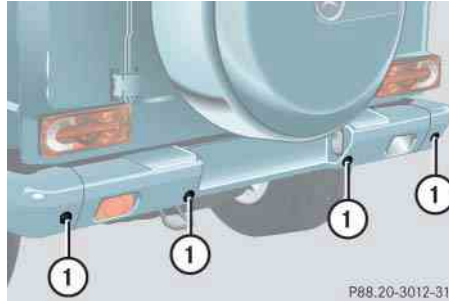

#### ① Sensors

- ▶ Use a mild car wash detergent, such as Mercedes-Benz approved Car Shampoo, with plenty of water and a soft, non-scratching cloth to clean sensors ① on the bumper.

**!** Do not apply strong pressure to the sensor covers. Applying strong pressure may damage the sensor covers.

Follow the instructions provided by the power washer manufacturer on maintaining a distance between the vehicle and the nozzle of the power washer.

**!** To prevent scratches, never apply strong force and only use a soft, non-scratching cloth when cleaning the sensors. Do not attempt to wipe dirty sensors with a dry cloth or sponge.

## Cleaning the rear view camera lens

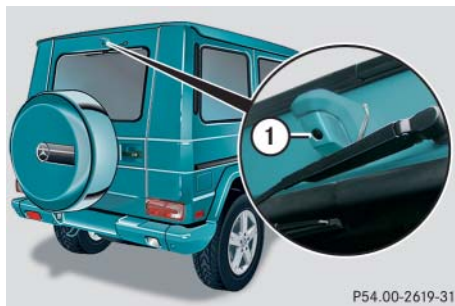

P54.00-2619-31

### ① Camera lens

- ▶ Only use clean water and a soft, non-scratching cloth to clean camera lens ①.

Be careful not to apply wax to camera lens ① when waxing the vehicle. If necessary, remove the wax using the Mercedes-Benz approved Car Shampoo with plenty of water.

**!** Do not clean the camera and the area around the camera:

- with a high-pressure cleaner
- with a dry cloth and high pressure
- with aggressive cleaning agents

You could otherwise damage the camera.

## Cleaning the windows and the wiper blades

### Warning!



For safety reasons, switch off wipers and remove SmartKey from starter switch before cleaning the windshield and/or the wiper blades. Otherwise, the wiper motor can suddenly turn on and cause injury.

**!** Never open the hood when the wiper arms are folded forward.

- ▶ Make sure the hood is fully closed.
- ▶ Switch off the ignition (▷ page 39).
- ▶ Remove the SmartKey from the starter switch.

**!** Do not pull on the wiper blade inserts. They could tear.

- ▶ Fold wiper arms forward until they snap into place. ▷▷



- ▷▷ Clean the wiper blade inserts with a clean cloth and detergent solution.
- ▶ Use a soft, clean cloth and a mild window cleaning solution on all outside and inside glass surfaces.

An automotive glass cleaner is recommended.

**!** Fold the windshield wiper arms back onto the windshield before turning the SmartKey in the starter switch.

Hold on to the wiper when folding the wiper arm back. If released, the force of the impact from the tensioning spring could crack the windshield.

**!** To clean the window interior, do not use a dry cloth, abrasives, solvents or cleaners containing solvents. Do not touch the inside of the front, rear or side windows with hard objects such as an ice scraper or ring. Doing so may damage the windows.

#### Light alloy wheels

If possible, clean wheels once a week.

- ▶ Use Mercedes-Benz approved Wheel Care, a soft bristle brush and a strong spray of water for cleaning the light alloy wheels.

**!** Only use acid-free cleaning materials. Acid may cause corrosion or damage the clear coat.

**!** The vehicle should not be parked for an extended period of time immediately after it has been cleaned, especially not after the wheel rims have been cleaned with wheel rim cleaner.

Wheel rim cleaners can lead to increased corrosion of the brake disks and brake pads. Non-approved wheel cleaners may also damage the wheel paint if the car is not driven after cleaning. Therefore, the vehicle's brake system should always be warmed-up before it is parked after cleaning. To do so, please drive your vehicle for several minutes to allow the brakes to dry.

When applying Mercedes-Benz approved Tire Care and Mercedes-Benz approved Wheel Care products, take care not to spray them on the brake disks.

#### Plastic and rubber parts

- ▶ Use a gentle dishwashing detergent or mild detergent for delicate fabrics as a washing solution.
- ▶ Wipe with a cloth moistened in a lukewarm solution.

The surface may temporarily change color. If this is the case, wait for it to dry.

#### Warning!



Do not use cleaners or cockpit care sprays containing solvents to clean the cockpit or the steering wheel. Cleaners containing solvents will make the surface porous and vehicle occupants could suffer serious injuries from plastic parts coming loose in the event of air bag deployment.

**!** Do not use oil, wax or scouring agents on these parts.

Never apply strong force and only use a soft, non-scratching cloth when cleaning the surface. Do not attempt to wipe the surface with a dry cloth or sponge.

Otherwise you may scratch or damage the surface.

### Hard plastic trim items

- ▶ Use Mercedes-Benz approved Interior Care, a soft, lint-free cloth and apply with light pressure.

**!** Never apply strong force and only use a soft, non-scratching cloth when cleaning the surface. Do not attempt to wipe the surface with a dry cloth or sponge.

Otherwise you may scratch or damage the surface.

### Steering wheel and gear selector lever

- ▶ Wipe with a damp cloth and dry thoroughly or clean with Mercedes-Benz approved Leather Care.

### Carpets

- ▶ Use Mercedes-Benz approved Carpet and Fabric Care for cleaning the carpets.

### Headliner

- ▶ Use a soft bristle brush or a dry-shampoo cleaner in case of excessive dirt.

### Seat belts

- ▶ Only use clear, lukewarm water and soap.

**!** The seat belts must not be treated with chemical cleaning agents. Do not dry the seat belts at temperatures above 176 °F (80 °C) or in direct sunlight.

### Warning!



Do not bleach or dye seat belts as this may severely weaken them. In a crash they may not be able to provide adequate protection.

### Vehicle care

#### Upholstery

Using aftermarket seat covers or wearing clothing that have the tendency to give off coloring (e.g. when wet, etc.) may cause the upholstery to become permanently discolored. By lining the seats with a proper intermediate cover, contact-discoloration will be prevented.

#### Leather upholstery

Please note that leather upholstery is a natural product and is therefore subject to a natural aging process. Leather upholstery may also react to certain ambient influences such as high humidity or high temperature by showing wrinkles for example.

- ▶ Wipe leather upholstery with a damp cloth and dry thoroughly or clean with Mercedes-Benz approved Leather Care.

**!** *Wipe with light pressure to avoid damage to the upholstery.*

Exercise particular care when cleaning perforated leather as its underside should not become wet.

#### Wood trims

- ▶ Dampen cloth using water and use damp cloth to clean wood trims in your vehicle.

**!** *Do not use solvents like tar remover or wheel cleaner nor polishes or waxes as these may be abrasive.*



**What to do if ...**

**Where will I find...?**

**Unlocking/locking in an emergency**

**Opening/closing in an emergency**

**Brush guard**

**Replacing SmartKey batteries**

**Replacing bulbs**

**Replacing wiper blades**

**Flat tire**

**Battery**

**Jump starting**

**Towing the vehicle**

**Fuses**

### What to do if ...

#### Lamps in instrument cluster

General information:

If any of the following lamps in the instrument cluster fails to come on during the

bulb self-check when switching on ignition, have the respective bulb checked and replaced if necessary.

| Problem  | Possible cause/consequence   | Suggested solution  |
|--|--|---|
|  The yellow ABS indicator lamp comes on while driving. | <p>You have engaged the differential locks. The ABS, ESP®, BAS, EBB and 4-ETS are switched off.</p> <p>The ABS has detected a malfunction and has switched off. The ESP®, BAS, EBB and 4-ETS are also switched off (see messages in multifunction display).</p> <p>The brake system is still functioning normally but without the ABS available.</p> <p>If the ABS control unit is malfunctioning, other systems such as the navigation system or Rear Parking Assist* may also be malfunctioning.</p> | <p>▶ The driving systems will switch on again after the differential locks have been disengaged.</p> <p>▶ Continue driving with added caution. Wheels may lock during hard braking, reducing steering capability.</p> <p>▶ Have the system checked at an authorized Mercedes-Benz Light Truck Center as soon as possible.</p> <p>Failure to follow these instructions increases the risk of an accident.</p> <p>▶ Read and observe messages in the multifunction display (&gt; page 338).</p> |

| Problem  | Possible cause/consequence   | Suggested solution   |
|--|--|--|
|  <p>The yellow ABS indicator lamp comes on while driving.</p> | <p>The charging voltage has fallen below 10 volts. The ABS has switched off.</p> <p>The battery might not be charged sufficiently.</p> | <p>When the voltage is above this value again, the ABS is operational again and the ABS indicator lamp should go out.</p> <p>If the ABS indicator lamp does not go out:</p> <ul style="list-style-type: none"> <li>▶ Have the generator (alternator) and the battery checked.</li> </ul> |

### What to do if ...

| Problem  | Possible cause/consequence                                 | Suggested solution  |
|--|--|---|
| <p><b>⚠ BRAKE</b> (USA only)    The red brake warning lamp comes on while driving.</p> <p><b>⚠</b> (Canada only)</p> | <p>There is insufficient brake fluid in the reservoir.</p> | <p>Risk of accident!</p> <ul style="list-style-type: none"> <li>▶ Carefully stop the vehicle in a safe location or as soon as it is safe to do so.</li> <li>▶ Apply the parking brake (▷ page 62).</li> <li>▶ Do <b>not</b> drive any further.</li> <li>▶ Contact an authorized Mercedes-Benz Light Truck Center.</li> </ul> <p>Do not add brake fluid! This will not solve the problem.</p> <ul style="list-style-type: none"> <li>▶ Read and observe messages in the multifunction display (▷ page 338).</li> </ul> |



### Warning!



Driving with the brake warning lamp illuminated can result in an accident. Have your brake system checked immediately if the brake warning lamp stays on.

Do not add brake fluid before checking the brake system. Overfilling the brake fluid reservoir can result in spilling brake fluid on hot engine parts and the brake fluid catching fire. You could be seriously burned.

**!** *If you find that the brake fluid in the brake fluid reservoir has fallen to the minimum mark or below, have the brake system checked for brake pad thickness and leaks.*

| Problem   |   | Possible cause/consequence   | Suggested solution  |
|---|---|--|---|
| <b>BRAKE</b> (USA only)<br> (Canada only)   | The red brake warning lamp comes on while driving and an acoustic warning sounds.   | You are driving with the parking brake set.                          | ▶ Release the parking brake (▷ page 55).  |
| <b>BRAKE</b> (USA only)<br> (Canada only)<br> | The red brake warning lamp and the yellow ABS indicator lamp come on when the engine is running and an acoustic warning sounds for approximately 5 seconds. | The EBB (▷ page 92) has detected a malfunction and has switched off. | ▶ Continue driving with added caution.<br>▶ Have the system checked at an authorized Mercedes-Benz Light Truck Center as soon as possible.<br><br>Failure to follow these instructions increases the risk of accidents. |



**Warning!**





Driving with the brake warning lamp illuminated can result in an accident. Have your brake system checked immediately if the brake warning lamp stays on.



### What to do if ...

| Problem  | Possible cause/consequence  | Suggested solution  |
|--|---|---|
| <p> (USA only)    The yellow engine malfunction indicator lamp comes on while driving.</p> <p> (Canada only)</p> | <p>There is a malfunction in:</p> <ul style="list-style-type: none"> <li>• The fuel management system</li> <li>• The ignition system</li> <li>• The emission control system</li> <li>• Systems which impact emissions</li> </ul> <p>Such malfunctions may result in excessive emissions values and may switch the engine to its limp-home (emergency operation) mode.</p> | <p>► Have the vehicle checked at an authorized Mercedes-Benz Light Truck Center as soon as possible . An on-board diagnostic connector is used by the service station to link the vehicle to the shop diagnostics system. It allows the accurate identification of system malfunctions through the readout of diagnostic trouble codes. It is located near the hood lock release on the upper left of the footwell.</p> |

**i** Some states may by law require you to visit a workshop as soon as the engine malfunction indicator lamp comes on. Check local requirements.

| Problem   |  | Possible cause/consequence   | Suggested solution   |
|---|--|--|--|
|  (USA only)    | The yellow engine malfunction indicator lamp comes on while driving. | A loss of pressure has been detected in the fuel system. The fuel filler cap may not be closed properly or the fuel system may be leaky. | <ul style="list-style-type: none"> <li>▶ Check the fuel filler cap (▷ page 264).</li> </ul> If it is not closed properly: <ul style="list-style-type: none"> <li>▶ Close the fuel filler cap.</li> </ul> If it is closed properly: <ul style="list-style-type: none"> <li>▶ Have the fuel system checked at an authorized Mercedes-Benz Light Truck Center.</li> </ul> |
|  (Canada only) |  |  |  |

### What to do if ...

| Problem   | Possible cause/consequence  | Suggested solution  |
|---|---|---|
| <p> The yellow ESP® warning lamp comes on and remains on while driving.</p> | <p>You have engaged the differential locks. The ABS, ESP®, BAS, EBB and 4-ETS are switched off.</p> <p>The ESP® has been switched off with the ESP® switch or has switched off due to a malfunction.</p> <p>Risk of accident!</p> <p>When the ESP® is switched off, it will not stabilize the vehicle if the system recognizes that the vehicle starts to skid or that a wheel is spinning.</p> <p>The cruise control is deactivated and cannot be switched on.</p> | <ul style="list-style-type: none"> <li>▶ The driving systems will switch on again after the differential locks have been disengaged.</li> <li>▶ Read and observe messages in the multifunction display (▷ page 338).</li> <li>▶ Switch the ESP® back on (▷ page 95). Exceptions: (▷ page 94).</li> <li>▶ If leaving the ESP® switched off, adapt your speed and driving to the prevailing road and weather conditions.</li> </ul> <p>If the ESP® cannot be switched on:</p> <ul style="list-style-type: none"> <li>▶ Read and observe messages in the multifunction display (▷ page 338).</li> <li>▶ Continue driving with added caution.</li> <li>▶ Adapt your speed and driving to the prevailing road and weather conditions.</li> <li>▶ Have the system checked at an authorized Mercedes-Benz Light Truck Center as soon as possible.</li> </ul> |

| Problem  | Possible cause/consequence  | Suggested solution   |
|--|---|--|
|  <p>The yellow ESP® warning lamp comes on and remains on while driving.</p> | <p>The ESP® is deactivated because of interrupted power supply. The ABS may still be operational.</p> <p>The ESP®, ABS, BAS, EBB or 4-ETS has detected a malfunction. All driving systems are switched off.</p> <p>Risk of accident!</p> <p>Adapt your speed and driving to the prevailing road conditions.</p> | <ul style="list-style-type: none"> <li>▶ Read and observe messages in the multifunction display (▷ page 338).</li> <li>▶ Read and observe messages in the multifunction display (▷ page 338).</li> </ul> |
| <p>The yellow fuel tank reserve warning lamp comes on while driving.</p>   | <p>The fuel level has dropped below the reserve mark.</p>   | <ul style="list-style-type: none"> <li>▶ Refuel at the next gas station (▷ page 264).</li> <li>▶ Read and observe messages in the multifunction display (▷ page 338).</li> </ul>                         |
| <p>The yellow fuel tank reserve warning lamp is blinking.</p>  | <p>The fuel cap is not closed tight.</p>  | <ul style="list-style-type: none"> <li>▶ Check the fuel filler cap (▷ page 264).</li> <li>▶ Read and observe messages in the multifunction display (▷ page 338).</li> </ul>                              |

### What to do if ...

| Problem   | Possible cause/consequence   | Suggested solution   |
|---|--|--|
|  The red seat belt telltale comes on for a maximum of 6 seconds after starting the engine. | The seat belt telltale reminds you and your passengers to fasten your seat belts before driving off.                           | <ul style="list-style-type: none"> <li>▶ Fasten your seat belts.</li> </ul> <p>Regardless of whether the seat belts are fastened or not, the seat belt telltale always comes on and remains lit for 6 seconds after starting the engine.</p> |
| You hear a warning chime for a maximum of 6 seconds after starting the engine.  | You have forgotten to fasten your seat belt.   | <ul style="list-style-type: none"> <li>▶ Fasten your seat belt.</li> </ul> <p>The warning chime stops sounding.</p>  |
| The red seat belt telltale comes on while the vehicle is standing still and the engine is running or during driving.  | You and/or your front passenger have forgotten to fasten your seat belts.  | <ul style="list-style-type: none"> <li>▶ Fasten your seat belts.</li> </ul> <p>The seat belt telltale goes out.</p>  |
|   | There are items placed on the front passenger seat and therefore the system senses the front passenger seat as being occupied. | <ul style="list-style-type: none"> <li>▶ Remove the items from the front passenger seat and put them in a safe place.</li> </ul> <p>The seat belt telltale goes out.</p>   |

| Problem  | Possible cause/consequence  | Suggested solution   |
|--|---|--|
|  <p>During driving the red seat belt telltale flashes and you additionally hear an intermittent warning chime with increasing intensity.</p> | <p>The vehicle's speed once exceeded 15 mph (25 km/h) and you and/or your front passenger have forgotten to fasten your seat belts.</p> | <p>► Fasten your seat belts.</p> <p>The seat belt telltale goes out and the warning chime stops sounding.</p>  |
|  | <p>There are items placed on the front passenger seat and therefore the system senses the front passenger seat as being occupied.</p>   | <p>► Remove the items from the front passenger seat and put them in a safe place.</p> <p>The seat belt telltale goes out and the warning chime stops sounding.</p> |

**i** After 60 seconds with an unfastened seat belt the warning chime stops sounding and the seat belt telltale illuminates continuously. The seat belt telltale will only go out if both, the driver's and the front passenger's seat belt are fastened, or the vehicle is standing still and a front door is opened.

### What to do if ...

| Problem   | Possible cause/consequence   | Suggested solution   |
|---|--|--|
| <b>SRS</b> The red SRS indicator lamp comes on while driving. | There is a malfunction in the restraint systems. The air bags or Emergency Tensioning Devices (ETDs) might deploy unexpectedly or may not deploy in an accident. | ► Drive with added caution to the nearest authorized Mercedes-Benz Light Truck Center and have the system checked. |

#### Warning!



In the event a malfunction of the SRS is indicated as outlined above, the SRS may not be operational. For your safety, we strongly recommend that you contact an authorized Mercedes-Benz Light Truck Center immediately to have the system checked; otherwise the SRS may not deploy when needed in an accident, which could result in serious or fatal injury, or it might deploy unexpectedly and unnecessarily which could also result in an accident and/or injury to you or to others.

| Problem  | Possible cause/consequence  | Suggested solution  |
|--|---|---|
|  <p>Combination low tire pressure/TPMS malfunction telltale for the Advanced TPMS illuminates continuously.</p> | <p>The Advanced TPMS detects a loss of pressure in at least one tire.</p> | <ul style="list-style-type: none"> <li>▶ Carefully bring the vehicle to a halt, avoiding abrupt steering and braking maneuvers. Observe the traffic situation around you.</li> <li>▶ Read and observe messages in the multifunction display (▷ page 338).</li> </ul> <p>If the tire inflation pressure in the respective tire(s) has (have) been corrected, the combination low tire pressure/TPMS malfunction telltale goes out after few minutes driving.</p> |
| <p>Combination low tire pressure/TPMS malfunction telltale for the Advanced TPMS flashes for 60 seconds and then stays illuminated.</p>  | <p>There is a malfunction in the Advanced TPMS.</p>                       | <ul style="list-style-type: none"> <li>▶ Read and observe messages in the multifunction display (▷ page 338).</li> <li>▶ Have the Advanced TPMS checked at an authorized Mercedes-Benz Light Truck Center.</li> </ul> <p>After the malfunction has been remedied the combination low tire pressure/TPMS malfunction telltale goes out after few minutes driving.</p>  |



### What to do if ...

#### Warning!



Each tire, including the spare (if provided), should be checked monthly when cold and inflated to the inflation pressure recommended by the vehicle manufacturer on the Tire and Loading Information placard on the driver's door B-pillar or, if available, the tire inflation pressure label on the inside of the fuel filler flap. If your vehicle has tires of a different size than the size indicated on the Tire and Loading Information placard or the tire inflation pressure label, you should determine the proper tire inflation pressure for those tires.

As an added safety feature, your vehicle has been equipped with a Advanced Tire Pressure Monitoring System (Advanced TPMS) that illuminates a low tire pressure telltale when one or more of your tires is significantly underinflated. Accordingly, when the low tire pressure telltale illuminates, you should stop and check your tires as soon as possible, and inflate them to the proper pressure.

Driving on a significantly underinflated tire causes the tire to overheat and can lead to tire failure.

Underinflation also reduces fuel efficiency and tire tread life, and may affect the vehicle's handling and stopping ability. Please note that the Advanced TPMS is not a substitute for proper tire maintenance, and it is the driver's responsibility to maintain correct tire pressure, even if underinflation has not reached the level to trigger illumination of the Advanced TPMS low tire pressure telltale.

USA only: Your vehicle has also been equipped with a Advanced TPMS malfunction indicator to indicate when the system is not operating properly. The Advanced TPMS malfunction indicator is combined with the low tire pressure telltale. When the system detects a malfunction, the telltale will flash for approximately 1 minute and then remain continuously illuminated. This sequence will continue upon subsequent vehicle start-ups as long as the malfunction exists.

When the malfunction indicator is illuminated, the system may not be able to detect or signal low tire pressure as intended.

Advanced TPMS malfunctions may occur for a variety of reasons, including the installation of replacement or alternate tires or wheels on the vehicle that prevent the Advanced TPMS from functioning properly. Always check the Advanced TPMS malfunction telltale after replacing one or more tires or wheels on your vehicle to ensure that the replacement or alternate tires and wheels allow the Advanced TPMS to continue to function properly.

Lamp in center console

| Problem  | Possible cause/consequence  | Suggested solution   |
|--|---|--|
|  <p>The front passenger front air bag off indicator lamp comes on and remains illuminated.</p>          | <p>A BabySmart™ child seat is installed on the front passenger seat. Therefore the passenger front air bag is switched off.</p> |  |
| <p>The front passenger front air bag off indicator lamp does not come on or does not remain illuminated with a BabySmart™ child seat properly installed on the front passenger seat.</p> | <p>The system is malfunctioning.</p>  | <ul style="list-style-type: none"> <li>▶ Have the system checked at an authorized Mercedes-Benz Light Truck Center as soon as possible.</li> <li>▶ Make sure there is nothing between seat cushion and child seat and check installation of the child seat.</li> <li>▶ If the front passenger front air bag off indicator lamp remains out, have the system checked at an authorized Mercedes-Benz Light Truck Center as soon as possible.</li> </ul> <p>Do not use the BabySmart™ restraint to transport children on the front passenger seat until the system has been repaired.</p> |

### What to do if ...

#### Vehicle status messages in the multifunction display





Warning and malfunction messages appear in the multifunction display located in the instrument cluster.





Certain warning and malfunction messages are accompanied by an audible signal.

Address these messages accordingly and follow the additional instructions given in this Operator's Manual.

Selecting the vehicle status message memory menu in the control system (▷ page 144) displays both cleared and uncleared messages.

High-priority messages appear in the multifunction display in red color.

Certain messages of high priority cannot be cleared from the multifunction display using the reset button (▷ page 130) or button , , , or  on the multifunction steering wheel.

Other messages of high priority and messages of less immediate priority can be cleared from the multifunction display using the reset button (▷ page 130) or button , , , or  on the multifunction steering wheel. They are then stored in the vehicle status message memory (▷ page 144). Remember that clearing a message will only make the message disappear. Clearing a message will not correct the condition that caused the message to appear.

#### Warning!



All categories of messages contain important information which should be taken note of and, where a malfunction is indicated, addressed as soon as possible at an authorized Mercedes-Benz Light Truck Center.

Failure to repair condition noted may cause damage not covered by the Mercedes-Benz Limited Warranty, or result in property damage or personal injury.

**Warning!**

No messages will be displayed if either the instrument cluster or the multifunction display is inoperative.

As a result, you will not be able to see information about your driving conditions, such as speed or outside temperature, warning/indicator lamps, malfunction/warning messages or the failure of any systems. Driving characteristics may be impaired.

If you must continue to drive, please do so with added caution. Contact an authorized Mercedes-Benz Light Truck Center as soon as possible.

**i** *Switching on the ignition causes all instrument cluster lamps (except high beam headlamp indicator lamp, and turn signal indicator lamps unless activated) as well as the multifunction display to come on. Make sure the lamps and multifunction display are in working order before starting your journey.*

On the pages that follow, you will find a compilation of the most important warning and malfunction messages that may appear in the multifunction display.

For your convenience the messages are divided into two sections:

- Text messages (▷ page 340)
- Symbol messages (▷ page 344)

### What to do if ...

#### Text messages

| Display message  | Possible cause/consequence   | Possible solution   |
|--|--|---|
| <p>ABS</p> <p>ABS not available differential locked</p>  | <p>You have engaged the differential locks.</p>  | <ul style="list-style-type: none"> <li>▶ The ABS switches on again after the differential locks have been disengaged.</li> </ul>  |
| <p>ABS, ESP inoperative</p> <p>See Operator's Manual</p> | <p>The ABS has detected a malfunction and has switched off.</p> <p>The ESP®, BAS, EBB and 4-ETS are also deactivated.</p> <p>The brake system is still functioning normally but without the ABS available.</p> | <ul style="list-style-type: none"> <li>▶ Continue driving with added caution. Wheels may lock during hard braking, reducing steering capability.</li> <li>▶ Have the system checked at an authorized Mercedes-Benz Light Truck Center as soon as possible.</li> </ul> <p>Failure to follow these instructions increases the risk of accident.</p> |

| Display message  | Possible cause/consequence  | Possible solution  |
|--|---|--|
| <p>ESP<br/>                     inoperative<br/>                     See<br/>                     Operator's<br/>                     Manual</p> | <p>The ESP® has switched off due to a malfunction or an interruption in the power supply.</p> <p>The brake system is still functioning normally but without the ESP®, ABS and BAS available.</p> <p>If in addition the ABS is malfunctioning, only partial engine output will be available.</p> | <ul style="list-style-type: none"> <li>▶ Continue driving with added caution.</li> <li>▶ Have the system checked at an authorized Mercedes-Benz Light Truck Center as soon as possible.</li> </ul> <p>Failure to follow these instructions increases the risk of accident.</p> |

### What to do if ...

| Display message  | Possible cause/consequence  | Possible solution  |
|--|---|--|
| Tire pressure displayed only after driving for a few minutes | The tire inflation pressure is being checked.   | ▶ Drive the vehicle for a few minutes.   |
| Tire pressure monitor currently unavailable                  | The Advanced TPMS is unable to monitor the tire pressure due to a nearby radio interference source. | ▶ As soon as the causes for the malfunction are no longer present, the Advanced TPMS automatically becomes active again after a few minutes driving.                         |
| Tire pressure monitor inoperative                            | The Advanced TPMS is malfunctioning.  | ▶ Have the Advanced TPMS checked at an authorized Mercedes-Benz Light Truck Center.<br>▶ Have the wheel sensors installed by an authorized Mercedes-Benz Light Truck Center. |

#### Warning!



Do not drive with a flat tire. A flat tire affects the ability to steer or brake the vehicle.

You may lose control of the vehicle. Continued driving with a flat tire will cause excessive heat build-up and possibly a fire.

| Display message                                       | Possible cause/consequence  | Possible solution  |
|---|---|--|
| Tire pressure monitor inoperative<br>No wheel sensors | There are wheels without appropriate wheel sensors mounted (e.g. winter tires).   | <ul style="list-style-type: none"> <li>▶ Have the Advanced TPMS checked at an authorized Mercedes-Benz Light Truck Center.</li> <li>▶ Have the wheel sensors installed at an authorized Mercedes-Benz Light Truck Center.</li> </ul>             |
| Wheel sensor missing                                  | One or more sensors malfunction (e.g. battery is empty).<br><br>The respective tire is indicated by --- instead of the tire inflation pressure in the multifunction display.                        | <ul style="list-style-type: none"> <li>▶ Have the Advanced TPMS checked at an authorized Mercedes-Benz Light Truck Center.</li> <li>▶ Have the appropriate wheel sensors installed at an authorized Mercedes-Benz Light Truck Center.</li> </ul> |
|   | One or more wheels without appropriate wheel sensors mounted (e.g. spare tire).<br><br>The respective tire is indicated by --- instead of the tire inflation pressure in the multifunction display. | <ul style="list-style-type: none"> <li>▶ Have the Advanced TPMS checked at an authorized Mercedes-Benz Light Truck Center.</li> <li>▶ Have the appropriate wheel sensors installed at an authorized Mercedes-Benz Light Truck Center.</li> </ul> |

**Warning!**



Do not drive with a flat tire. A flat tire affects the ability to steer or brake the vehicle.

You may lose control of the vehicle. Continued driving with a flat tire will cause excessive heat build-up and possibly a fire.



## What to do if ...

### Symbol messages

| Display symbol   | Display message | Possible cause/consequence   | Possible solution  |
|--|-----------------|--|--|
|  |                 | <p>The battery is no longer charging.<br/>Possible causes:</p> <ul style="list-style-type: none"> <li>• alternator malfunctioning</li> <li>• broken poly-V-belt</li> </ul> | <ul style="list-style-type: none"> <li>▶ Stop the vehicle in a safe location or as soon as it is safe to do so.</li> <li>▶ Apply the parking brake (▷ page 62).</li> <li>▶ Turn off the engine.</li> <li>▶ Check the poly-V-belt.</li> </ul> <p>If it is broken:</p> <ul style="list-style-type: none"> <li>▶ Do not continue to drive.</li> </ul> <p>Otherwise, the engine will overheat due to an inoperative water pump which may result in damage to the engine.</p> <ul style="list-style-type: none"> <li>▶ Contact an authorized Mercedes-Benz Light Truck Center.</li> </ul> <p>If it is in order:</p> <ul style="list-style-type: none"> <li>▶ Contact an authorized Mercedes-Benz Light Truck Center immediately.</li> </ul> |

| Display symbol  | Display message | Possible cause/consequence                                      | Possible solution   |
|---|-----------------|---|---|
|  |                 | The battery was charged with a battery charger or jump started. | ▶ Have the battery checked at a service station.  |
|   |                 | The battery has insufficient voltage.                           | ▶ Turn off unnecessary electric consumers that are currently not needed, e.g. seat heating.<br>▶ Have the battery checked at a service station. |

### What to do if ...

| Display symbol   | Display message         | Possible cause/consequence                          | Possible solution  |
|--|-------------------------|---|--|
|  | Check brake fluid level | There is insufficient brake fluid in the reservoir. | <p>Risk of accident!</p> <ul style="list-style-type: none"> <li>▶ Carefully stop the vehicle in a safe location or as soon as it is safe to do so.</li> <li>▶ Apply the parking brake (▷ page 62).</li> <li>▶ Do <b>not</b> drive any further.</li> <li>▶ Contact an authorized Mercedes-Benz Light Truck Center.</li> </ul> <p>Do not add brake fluid! This will not solve the problem.</p> |





### Warning!



Driving with the message Check brake fluid level displayed can result in an accident. Have your brake system checked immediately.

Do not add brake fluid before checking the brake system. Overfilling the brake fluid reservoir can result in spilling brake fluid on hot engine parts and the brake fluid catching fire. You can be seriously burned.

**!** *If you find that the brake fluid in the brake fluid reservoir has fallen to the minimum mark or below, have the brake system checked for brake pad thickness and leaks.*

| Display symbol  | Display message                         | Possible cause/consequence                    | Possible solution  |
|---|---|---|--|
|  (USA only)<br> (Canada only) | Release parking brake                   | You are driving with the parking brake set.   | ▶ Release the parking brake (▷ page 55).   |
|    | Brake wear                              | The brake pads have reached their wear limit. | ▶ Have the brake pads replaced as soon as possible.  |
|    | Top up coolant<br>See Operator's Manual | The coolant level is too low.                 | ▶ Add coolant (▷ page 274).<br>▶ If you have to add coolant frequently, have the cooling system checked at an authorized Mercedes-Benz Light Truck Center. |

**!** Brake pad thickness must be visually checked by a qualified technician at the intervals specified in the Maintenance Booklet.

**!** Do not ignore the low engine coolant level warning. Extended driving with this message and symbol displayed may cause serious engine damage not covered by the Mercedes-Benz Limited Warranty.

*Do not drive without sufficient amount of coolant in the cooling system. The engine will overheat, causing major engine damage.*

**Warning!**



Do not spill antifreeze on hot engine parts. Antifreeze contains ethylene glycol which may burn if it comes into contact with hot engine parts. You could be seriously burned.

### What to do if ...

| Display symbol   | Display message                     | Possible cause/consequence   | Possible solution   |
|--|-------------------------------------|--|---|
|  | Coolant<br>Stop, turn<br>engine off | The coolant is too hot.<br><br>Among other possible causes, the poly-V-belt could be broken. | <ul style="list-style-type: none"> <li>▶ Stop the vehicle in a safe location or as soon as it is safe to do so.</li> <li>▶ Apply the parking brake (▷ page 62).</li> <li>▶ Turn off the engine.</li> <li>▶ Check the poly-V-belt.</li> </ul> <p>If it is broken:</p> <ul style="list-style-type: none"> <li>▶ Do not continue to drive.<br/><br/>Otherwise, the engine will overheat due to an inoperative water pump which may result in damage to the engine.</li> <li>▶ Contact an authorized Mercedes-Benz Light Truck Center.</li> </ul> <p>If it is in order:</p> <ul style="list-style-type: none"> <li>▶ Wait for the message to disappear before restarting the engine.</li> </ul> <p>Doing otherwise could result in serious engine damage that is not covered by the Mercedes-Benz Limited Warranty.</p> <p>(Continued on next page)</p> |

| Display symbol | Display message | Possible cause/consequence | Possible solution  |
|----------------|-----------------|----------------------------|--|
|                |                 |                            | <ul style="list-style-type: none"> <li>▶ Observe the coolant temperature gauge in the instrument cluster (▷ page 26).</li> <li>If the temperature rises again:</li> <li>▶ Contact an authorized Mercedes-Benz Light Truck Center immediately.</li> </ul> |

**Warning!**



Driving when your engine is overheated can cause some fluids which may have leaked into the engine compartment to catch fire. You could be seriously burned.



Steam from an overheated engine can cause serious burns and can occur just by opening the hood. Stay away from the engine if you see or hear steam coming from it.

Turn off the engine, get out of the vehicle and do not stand near the vehicle until the engine has cooled down.

During severe operating conditions and stop-and-go city traffic, the coolant temperature may rise close to 248°F (120°C).

**!** *The engine should not be operated with the coolant temperature above 248°F (120°C). Doing so may cause serious engine damage which is not covered by the Mercedes-Benz Limited Warranty.*

### What to do if ...

| Display symbol   | Display message                          | Possible cause/consequence                               | Possible solution   |
|--|--|--|---|
|  |  | The cooling fan for the coolant is malfunctioning.       | <ul style="list-style-type: none"> <li>▶ Observe the coolant temperature gauge in the multifunction display (▷ page 26).<br/>If the coolant temperature is below 120°C, you may continue driving to the nearest specialist workshop.</li> <li>▶ Avoid placing heavy loads on the engine (e.g. by driving uphill) as well as stop-and-go traffic.</li> <li>▶ Have the fan replaced as soon as possible.</li> </ul> |
|  | Cr. control and SPEED-TRONIC inoperative | The cruise control is malfunctioning.                    | <ul style="list-style-type: none"> <li>▶ Have the cruise control checked at an authorized Mercedes-Benz Light Truck Center.</li> </ul>  |
|  |  | You are attempting to drive with one or more doors open. | <ul style="list-style-type: none"> <li>▶ Close the doors.</li> </ul>  |

| Display symbol  | Display message   | Possible cause/consequence       | Possible solution  |
|---|---|----------------------------------|--|
|  | <p>USA only:<br/>At next<br/>gas station<br/>add<br/>1.0 qt<br/>engine oil</p> <p>Canada only:<br/>At next<br/>gas station<br/>add<br/>1.0 liter<br/>engine oil</p> | The engine oil level is too low. | <ul style="list-style-type: none"> <li>▶ Add engine oil (▷ page 273) and check the engine oil level (▷ page 270).</li> </ul> |

When the message At next gas station add 1.0 qt engine oil (Canada: 1.0 liter) appears while the engine is running and at operating temperature, the engine oil level has dropped to approximately the minimum level.

When this occurs, the warning will first come on intermittently and then stay on if the oil level drops further.





Visually check for oil leaks. If no oil leaks are noted, continue to drive to the nearest service station where the engine oil should be topped to the required level with an approved engine oil. For information on approved engine oils, refer to the Factory Approved Service Products pamphlet (USA only) or contact an authorized Mercedes-Benz Light Truck Center.



### What to do if ...

| Display symbol   | Display message                           | Possible cause/consequence   | Possible solution  |
|--|---|--|--|
|  | Engine oil level<br>Stop, turn engine off | There is no oil in the engine. There is a danger of engine damage.   | <ul style="list-style-type: none"> <li>▶ Stop the vehicle in a safe location or as soon as it is safe to do so.</li> <li>▶ Turn off the engine.</li> <li>▶ Add engine oil (▷ page 273) and check the engine oil level (▷ page 270).</li> </ul> |
|  | Engine oil level<br>Visit workshop        | The engine oil has dropped to a critical level.  | <ul style="list-style-type: none"> <li>▶ Check the engine oil level (▷ page 270) and add engine oil as required (▷ page 273).</li> <li>▶ If you must add engine oil frequently, have the engine checked for possible leaks.</li> </ul>         |
|  |   | You have added too much engine oil. There is a risk of damaging the engine and/or the catalytic converter. | <ul style="list-style-type: none"> <li>▶ Have excess oil siphoned or drained off.</li> </ul> <p>Observe all legal requirements with respect to its disposal.</p>   |
|  |   | It may be that there is water in the engine oil.   | <ul style="list-style-type: none"> <li>▶ Have the engine oil checked at an authorized Mercedes-Benz Light Truck Center.</li> </ul>   |
|  |   | The measuring system is malfunctioning.  | <ul style="list-style-type: none"> <li>▶ Have the measuring system checked at an authorized Mercedes-Benz Light Truck Center.</li> </ul>   |

**!** *The engine oil level warnings should not be ignored. Extended driving with the symbol displayed could result in serious engine damage that is not covered by the Mercedes-Benz Limited Warranty.*

| Display symbol   | Display message    | Possible cause/consequence   | Possible solution  |
|--|--------------------|--|--|
|  | Reserve fuel level | The fuel level has dropped below the reserve mark.   | ▶ Refuel at the next gas station (▷ page 264).   |
|  | Gas cap is open    | A loss of pressure has been detected in the fuel system. The fuel filler cap may not be closed properly or the fuel system may be leaky. | ▶ Check the fuel filler cap (▷ page 264).<br>If it is not closed properly:<br>▶ Close the fuel filler cap.<br>If it is closed properly:<br>▶ Have the fuel system checked at an authorized Mercedes-Benz Light Truck Center. |
|  |                    | You are driving with the hood open.  | Risk of accident!<br>▶ Stop the vehicle in a safe location or as soon as it is safe to do so.<br>▶ Close the hood (▷ page 269).  |
|  | Remove key         | You have forgotten to remove the SmartKey from the starter switch.   | ▶ Remove the SmartKey from the starter switch.   |
|  | Get a new key      | The SmartKey is no longer functional.  | ▶ Contact an authorized Mercedes-Benz Light Truck Center.  |

### What to do if ...

| Display symbol   | Display message        | Possible cause/consequence  | Possible solution   |
|--|------------------------|---|---|
|  | 3rd brake lamp         | The high mounted brake lamp is malfunctioning. This message will only appear if a critical number of LEDs have stopped working. | ▶ Contact an authorized Mercedes-Benz Light Truck Center as soon as possible.   |
|  | AUTO-Light inoperative | The light sensor is malfunctioning. The headlamps switch on automatically.  | ▶ Contact an authorized Mercedes-Benz Light Truck Center as soon as possible.<br><br>To switch off the headlamps (U.S. vehicles only):<br><br>▶ In the control system, set lamp operation to manual mode (▷ page 151).<br><br>▶ Switch off the headlamps using the exterior lamp switch (▷ page 117). |
|  | Brake lamp left        | The left brake lamp is malfunctioning.  | ▶ Replace the bulb as soon as possible (▷ page 385).  |
|  | Brake lamp right       | The right brake lamp is malfunctioning.   | ▶ Replace the bulb as soon as possible (▷ page 385).  |

| Display symbol   | Display message              | Possible cause/consequence                          | Possible solution   |
|--|------------------------------|---|---|
|  | Front foglamp left           | The left front fog lamp is malfunctioning.          | ► Replace the bulb as soon as possible (▷ page 382).                          |
|  | Front foglamp right          | The right front fog lamp is malfunctioning.         | ► Replace the bulb as soon as possible (▷ page 382).                          |
|  | Front left side marker lamp  | The left front side marker lamp is malfunctioning.  | ► Replace the bulb as soon as possible (▷ page 384).                          |
|  | Front right side marker lamp | The right front side marker lamp is malfunctioning. | ► Replace the bulb as soon as possible (▷ page 384).                          |
|  | High beam left               | The left high beam lamp is malfunctioning.          | ► Contact an authorized Mercedes-Benz Light Truck Center as soon as possible. |
|  | High beam right              | The right high beam lamp is malfunctioning.         | ► Contact an authorized Mercedes-Benz Light Truck Center as soon as possible. |

### What to do if ...

| Display symbol   | Display message                               | Possible cause/consequence   | Possible solution   |
|--|---|--|---|
|  | License plate lamp, left                      | The left license plate lamp is malfunctioning.   | ► Replace the bulb as soon as possible (▷ page 387).                          |
|  | License plate lamp, right                     | The right license plate lamp is malfunctioning.  | ► Replace the bulb as soon as possible (▷ page 387).                          |
|  | Low beam left                                 | The left low beam lamp is malfunctioning.  | ► Contact an authorized Mercedes-Benz Light Truck Center as soon as possible. |
|  | Low beam right                                | The right low beam lamp is malfunctioning.   | ► Contact an authorized Mercedes-Benz Light Truck Center as soon as possible. |
|  | Parking lamp front left<br>Auxiliary bulb on  | The left front parking lamp is malfunctioning. A substitute bulb has been brought into use.  | ► Replace the bulb as soon as possible (▷ page 380).                          |
|  | Parking lamp front right<br>Auxiliary bulb on | The right front parking lamp is malfunctioning. A substitute bulb has been brought into use. | ► Replace the bulb as soon as possible (▷ page 380).                          |

| Display symbol  | Display message                      | Possible cause/consequence   | Possible solution   |
|---|--------------------------------------|--|---|
|  | Rear fog lamp                        | The rear fog lamp is malfunctioning.   | ▶ Replace the bulb as soon as possible (▷ page 386).                    |
|   | Rear fog lamp<br>Auxiliary bulb on   | A lamp is malfunctioning. A substitute bulb has been brought into use.                                     | ▶ Switch off the rear fog lamp (▷ page 121).                            |
|   | Reverse lamp right                   | The right backup lamp is malfunctioning.   | ▶ Replace the bulb as soon as possible (▷ page 386).                    |
|   | Switch off lights                    | You have removed the SmartKey from the starter switch, opened the driver's door and left the headlamps on. | ▶ Switch off the headlamps using the exterior lamp switch (▷ page 117). |
|   | Tail lamp left<br>Auxiliary bulb on  | The left tail lamp is malfunctioning. A substitute bulb has been brought into use.                         | ▶ Replace the bulb as soon as possible (▷ page 385).                    |
|   | Tail lamp right<br>Auxiliary bulb on | The right tail lamp is malfunctioning. A substitute bulb has been brought into use.                        | ▶ Replace the bulb as soon as possible (▷ page 385).                    |

### What to do if ...

| Display symbol   | Display message                              | Possible cause/consequence   | Possible solution                                    |
|--|--|--|--|
|  | Turn signal front left<br>Auxiliary bulb on  | The left front turn signal lamp is malfunctioning. A substitute bulb has been brought into use.  | ▶ Replace the bulb as soon as possible (▷ page 383). |
|  | Turn signal front right<br>Auxiliary bulb on | The right front turn signal lamp is malfunctioning. A substitute bulb has been brought into use. | ▶ Replace the bulb as soon as possible (▷ page 383). |
|  | Turn signal rear left<br>Auxiliary bulb on   | The left rear turn signal lamp is malfunctioning. A substitute bulb has been brought into use.   | ▶ Replace the bulb as soon as possible (▷ page 385). |
|  | Turn signal rear right<br>Auxiliary bulb on  | The right rear turn signal lamp is malfunctioning. A substitute bulb has been brought into use.  | ▶ Replace the bulb as soon as possible (▷ page 385). |

| Display symbol   | Display message                  | Possible cause/consequence  | Possible solution   |
|--|----------------------------------|---|---|
|  | Turn signal in left side mirror  | The turn signal in the left exterior rear view mirror is malfunctioning. This message will only appear if a critical number of LEDs have stopped working.                           | ▶ Contact an authorized Mercedes-Benz Light Truck Center as soon as possible.   |
|  | Turn signal in right side mirror | The turn signal in the right exterior rear view mirror is malfunctioning. This message will only appear if a critical number of LEDs have stopped working.                          | ▶ Contact an authorized Mercedes-Benz Light Truck Center as soon as possible.   |
|  | Turn off lights or remove key    | You have opened the driver's door while the exterior lamp switch is in position <b>AUTO</b> and the SmartKey is still in the starter switch.<br><br>The parking lamps are still on. | ▶ Switch off the headlamps using the exterior lamp switch (> page 117).<br>or<br>▶ Remove the SmartKey from the starter switch. |



### What to do if ...

| Display symbol | Display message                             | Possible cause/consequence   | Possible solution  |
|----------------|---|--|--|
| <b>SRS</b>     | Restraint system Service Visit workshop     | There is a malfunction in the restraint systems. The air bags or Emergency Tensioning Devices (ETDs) might deploy unexpectedly or may not deploy in an accident. | ► Drive with added caution to the nearest authorized Mercedes-Benz Light Truck Center and have the system checked. |
|                | Restraint system malfunction Visit workshop | There is a malfunction in the restraint systems. The air bags or Emergency Tensioning Devices (ETDs) might deploy unexpectedly or may not deploy in an accident. | ► Drive with added caution to the nearest authorized Mercedes-Benz Light Truck Center and have the system checked. |

### Warning!



In the event a malfunction of the SRS is indicated as outlined above, the SRS may not be operational. For your safety, we strongly recommend that you contact an authorized Mercedes-Benz Light Truck Center immediately to have the system checked;

otherwise the SRS may not deploy when needed in an accident, which could result in serious or fatal injury, or it might deploy unexpectedly and unnecessarily which could also result in an accident and/or injury to you or to others.

| Display symbol   | Display messages       | Possible cause/consequence  | Possible solution   |
|--|------------------------|---|---|
|  | Caution<br>Tire defect | One or more tires are deflating.<br>The respective tire is shown in the multifunction display.  | <ul style="list-style-type: none"> <li>▶ Carefully bring the vehicle to a halt, avoiding abrupt steering and braking maneuvers.</li> <li>▶ If necessary, change the wheel (▷ page 391).</li> </ul>  |
|  | Check<br>tires         | <p>The tire pressure in one or more tires is already below the minimum value.</p> <p>The respective tire is shown in the multifunction display.</p> | <ul style="list-style-type: none"> <li>▶ Carefully bring the vehicle to a halt, avoiding abrupt steering and braking maneuvers.</li> <li>▶ Check and adjust tire pressure as required.</li> <li>▶ If necessary, change the wheel (▷ page 391).</li> </ul> |

**Warning!**



Do not drive with a flat tire. A flat tire affects the ability to steer or brake the vehicle.

You may lose control of the vehicle. Continued driving with a flat tire will cause excessive heat build-up and possibly a fire.

### What to do if ...

| Display symbol  | Display messages                        | Possible cause/consequence   | Possible solution   |
|---|---|--|---|
|  | Correct the tire pressure               | The pressure is too low in one or more tires.                              | ▶ Check and correct tire inflation pressure as required (▷ page 288).   |
|   | Tire pressure<br>Caution<br>Tire defect | One or more tires are deflating.   | ▶ Carefully bring the vehicle to a halt, avoiding abrupt steering and braking maneuvers.<br>▶ If necessary, change the wheel (▷ page 391).  |
|   | Tire pressure<br>Check tires            | The tire pressure in one or more tires is already below the minimum value. | ▶ Carefully bring the vehicle to a halt, avoiding abrupt steering and braking maneuvers.<br>▶ Check and adjust tire pressure as required.<br>▶ If necessary, change the wheel (▷ page 391). |

### Warning!



Do not drive with a flat tire. A flat tire affects the ability to steer or brake the vehicle.

You may lose control of the vehicle. Continued driving with a flat tire will cause excessive heat build-up and possibly a fire.





| Display symbol  | Display message                   | Possible cause/consequence  | Possible solution  |
|---|-----------------------------------|---|--|
| <div style="background-color: black; color: white; padding: 2px; display: inline-block;">LOW<br/>HIGH</div> | Transfer case<br>Visit workshop   | The transfer case is malfunctioning.  | <ul style="list-style-type: none"> <li>▶ Do not switch the transfer case on.</li> <li>▶ Contact an authorized Mercedes-Benz Light Truck Center as soon as possible.</li> </ul> |
|   | TC shift procedure canceled       | The shift process in the transfer case was canceled because of a malfunction.       | ▶ Repeat the shift process (▷ page 170).   |
|   | TC shift conditions not fulfilled | You have not met the shift conditions for a selection process in the transfer case. | ▶ Repeat the shift process (▷ page 170).   |
|   | TC in neutral                     | No gear has been selected in the transfer case, it is in <b>NEUTRAL</b> .           | ▶ Engage transfer case to gear position <b>HIGH</b> or <b>LOW</b> (▷ page 170).  |



**Warning!**



If the transfer case is in **NEUTRAL**, the **P** position of the transmission will not hold the vehicle. The parking brake must be applied to hold vehicle in place.

### What to do if ...

| Display symbol   | Display message      | Possible cause/consequence  | Possible solution   |
|--|----------------------|---|---|
|  | Tele Aid inoperative | One or more main functions of the Tele Aid system are malfunctioning.   | Have the Tele Aid system checked at an authorized Mercedes-Benz Light Truck Center. |
|  | Function unavailable | This message appears if button  or  on the multifunction steering wheel is pressed and the vehicle is not equipped with a telephone*. |   |
|  |                      | This message will appear whenever the tailgate is open.   | ► Close the tailgate.   |

| Display symbol  | Display message     | Possible cause/consequence  | Possible solution   |
|---|---------------------|---|---|
|  |                     | <p>Certain electronic systems are unable to relay information to the control system. The following systems may have failed:</p> <ul style="list-style-type: none"> <li>• Coolant temperature display</li> <li>• Tachometer</li> <li>• Cruise control display</li> </ul> | <p>▶ Have the electronic systems checked at an authorized Mercedes-Benz Light Truck Center.</p> |
|  | Clean fuel filter   |   | <p>▶ Contact an authorized Mercedes-Benz Light Truck Center as soon as possible.</p>            |
|  | Top up washer fluid | The fluid level has dropped to about $\frac{1}{3}$ of total reservoir capacity.   | <p>▶ Add washer fluid (▷ page 275).</p>   |

### Where will I find...?

#### First aid kit

**i** Check expiration dates and contents for completeness at least once a year and replace missing/expired items.

The first aid kit is stored in the storage pocket in the front passenger door.



① First aid kit

#### Vehicle tool kit

The vehicle tool kit is stored in a storage compartment in the rear footwell.

The following is included:

- Wheel wrench
- Pump handle for vehicle jack
- Key for opening/closing the tilt/sliding sunroof in an emergency
- Screwdriver
- Fuse extractor

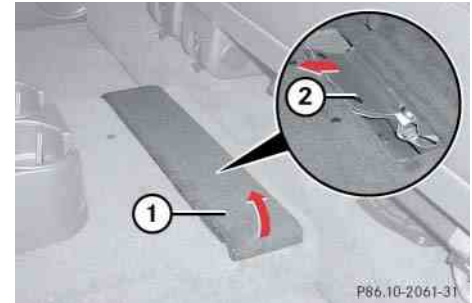

① Cover

② Tab

▶ Fold cover ① to the side.

▶ Pull vehicle tool kit out of the compartment using tab ②.

## Vehicle jack

The vehicle jack is stored in a storage compartment under the rear bench seat on the passenger side.



- ① Cover
- ② Tab
- ③ Vehicle jack

- ▶ Fold the rear bench seat forward (▷ page 207).
- ▶ Open cover ①.
- ▶ Open tab ② and remove vehicle jack ③ from the compartment.

### Warning!



The jack is designed exclusively for jacking up the vehicle under the axle housing. To help avoid personal injury, use the jack only to lift the vehicle during a wheel change. Never get beneath the vehicle while it is supported by the jack. Keep hands and feet away from the area under the lifted vehicle. Always firmly set parking brake and block wheels before raising vehicle with jack.

Do not disengage parking brake while the vehicle is raised. Be certain that the jack is always vertical (plumb line) when in use, especially on hills. Always try to use the jack on level surface.

Make sure the jack is positioned correctly under the axle housing. Always lower the vehicle onto sufficient capacity jackstands before working under the vehicle.

If the vehicle is not raised as described, it could slip off the jack as a result of vibrations (e.g. opening or closing a door or the tailgate).

Observe the safety guidelines in the “Flat tire” section (▷ page 390) when using the vehicle jack.



### Where will I find...?

#### CD changer

The CD changer is located on the driver's side of the cargo compartment.



#### CD changer

For information on CD changer operation, see separate COMAND system operating instructions.

#### Spare wheel

The spare wheel is located under a cover on the outside of the vehicle's tailgate. For information on rim and tire specifications, see "Rims and tires" (▷ page 416).

#### Removing cover



#### ① Tab

- ▶ Fold tab ① downwards.

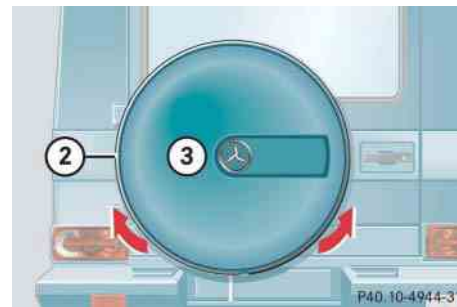

#### ② Cover ring

#### ③ Cover plate

- ▶ Pull cover ring ② slightly outwards in direction of arrows and remove.
- ▶ Pull cover plate ③ towards you.

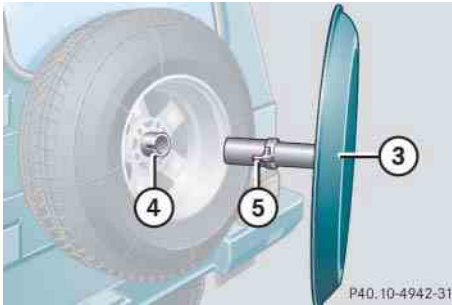

- ③ Cover plate
- ④ Recess
- ⑤ Catch

**i** When replacing cover plate ③, make sure catch ⑤ engages in recess ④.

Make sure tab ① faces downwards when mounting cover ring ②.

For safety reasons, check regularly that the spare wheel is securely fastened.

### Removing the spare wheel

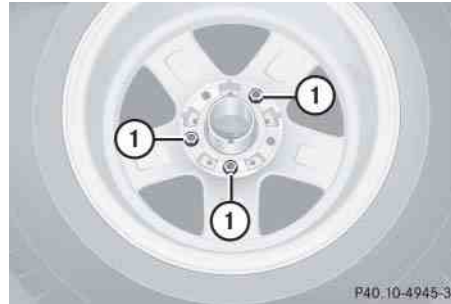

- ① Mounting screws
- ▶ Unscrew mounting screws ①.
- ▶ Remove the spare wheel.

### Warning!



Make sure no one is injured when removing the spare wheel.

Grip wheel from the sides.

Keep hands from beneath the wheel.

**i** After changing the wheel, secure the damaged wheel on the spare wheel carrier. Make sure the wheel cannot come loose.

Cover the wheel with the cover plate.

Repair or replace damaged tire as soon as possible and return spare tire as original spare.

For more information on changing the wheel, see “Flat tire” (▷ page 390).



### Unlocking/locking in an emergency

#### Unlocking the vehicle

If you cannot unlock the vehicle with the SmartKey, open the driver's door and the tailgate using the mechanical key.

**i** *Unlocking the driver's door and the tailgate with the mechanical key will trigger the anti-theft alarm system.*

To cancel the alarm:

- Press button  or  on the SmartKey.
- Insert the SmartKey in the starter switch.

#### Removing the mechanical key

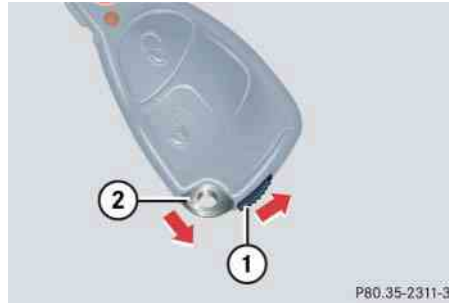

- ① Mechanical key locking tab
- ② Mechanical key

- ▶ Move locking tab ① in direction of arrow.
- ▶ Slide the mechanical key ② out of the housing.

#### Unlocking the driver's door

- ▶ Insert the mechanical key into the driver's door lock cylinder until it stops.
- ▶ Turn the mechanical key counterclockwise until the locking knob moves up. The driver's door is unlocked.
- ▶ Remove the mechanical key.
- ▶ Press lock cylinder and pull on door handle to open the driver's door.

Unlocking/locking in an emergency

Unlocking the tailgate

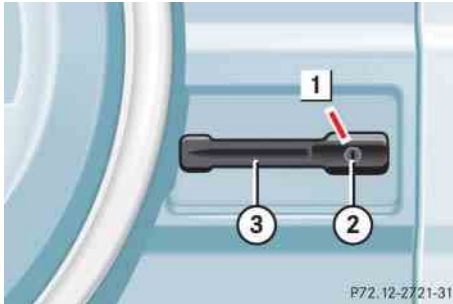

F72\_12-2721-31

- 1 Unlocking in an emergency
- ② Lock cylinder
- ③ Door handle

- ▶ Insert the mechanical key into lock cylinder ②.
- ▶ Turn the mechanical key counterclockwise to position 1 and release it.
- ▶ Remove the mechanical key.
- ▶ Press lock cylinder ② and pull on door handle ③ to open the tailgate.

**Warning!**



The tailgate swings open to one side. Always make sure there is sufficient clearance for tailgate.

**Locking the vehicle**

If you cannot lock the vehicle with the SmartKey, lock the vehicle with the mechanical key carrying out the following steps:

- ▶ Close the front passenger door, the rear doors and the tailgate.
- ▶ Open the driver's door.
- ▶ Press the central locking switch in the center console (▷ page 107).

The locking knobs on the front passenger door, the rear doors and the tailgate move down.

If the vehicle battery is disconnected or drained:

- ▶ Press down the locking knobs on the front passenger door, the rear doors and the tailgate manually.
- ▶ Exit the vehicle. ▷▷

### Unlocking/locking in an emergency

- ▷▷ Close the driver's door.
  - ▶ Slide the mechanical key out of the SmartKey (▷ page 370).
  - ▶ Insert the mechanical key into the driver's door lock cylinder until it stops.
  - ▶ Turn the mechanical key clockwise.  
The vehicle is locked.
  - ▶ Check if the tailgate is locked. If necessary lock the tailgate with the mechanical key.

**i** This procedure does not arm the anti-theft alarm system, nor does it lock the fuel filler flap.

#### Fuel filler flap

The emergency release is located on the passenger side of the cargo compartment behind the rear trim panel.

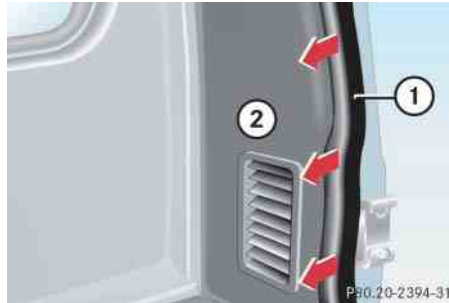

- ① Edge protection
- ② Rear trim panel
- ▶ Open the tailgate.
- ▶ Remove edge protection ① from the door pillar.
- ▶ Remove rear trim panel ②.



- ③ Release strap
- ▶ Pull release strap ③ upwards.  
The fuel filler flap is unlocked.
- ▶ Open the fuel filler flap (▷ page 264).

### Manually unlocking the gear selector lever

In case of power failure the gear selector lever can be manually unlocked, e.g. to tow the vehicle.



① Tool

- ▶ Insert a suitable tool ① (e.g. a ball point pen) into the covered opening.
- ▶ Perform the following two steps simultaneously:
  - ▶ Push tool ① down in direction of the arrow.
  - ▶ Move the gear selector lever from park position **P**.
- ▶ Remove tool ① from the opening.

The cover returns to its closed position after moving the gear selector lever to positions **D+** and **D-**.

**i** The gear selector lever is locked again when moving it to park position **P**.

### Opening/closing in an emergency

#### Tilt/sliding sunroof

You can open or close the tilt/sliding sunroof manually should an electrical malfunction occur.

The tilt/sliding sunroof drive is located on the driver's side of the cargo compartment behind the rear trim panel.

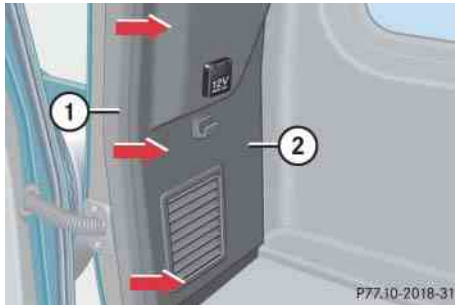

- ① Edge protection
- ② Rear trim panel

- ▶ Open the tailgate.
- ▶ Remove edge protection ① from the door pillar.
- ▶ Remove rear trim panel ②.



- ③ Key
- ④ Screwdriver

**i** Do not disconnect electrical connectors.

- ▶ Take the vehicle tool kit out of its storage compartment (▷ page 366).
- ▶ Take key ③ and screwdriver ④ out of the vehicle tool kit.
- ▶ Fit key ③ into hexagon nut of drive.
- ▶ Insert screwdriver ④ (as a lever) into hole of key ③.
- ▶ Turn screwdriver ④ clockwise to
  - slide sunroof closed
  - raise sunroof at the rear
- ▶ Turn screwdriver ④ counterclockwise to
  - slide sunroof open
  - lower sunroof at the rear

▼ **Brush guard**

The brush guard is available on G 55 AMG (U.S vehicles only).



**Warning!**



The brush guard is designed solely to enhance the appearance of the vehicle and help protect grille and headlights from minor mishaps, either on- or off-road. Since the safety characteristics are limited in the event of an accident, brush guards are not intended to prevent injury or damage in the event of an accident. Also check state and local regulations on installation and use.

Raise and lower brush guard in an open space with plenty of room.

To help prevent personal injury when opening or closing the brush guard, use extreme caution not to trap hands or feet.

The brush guard must be in raised and locked position while driving.

**i** Only lower brush guard to clean headlamps or to replace bulbs.

**Lowering and raising brush guard**

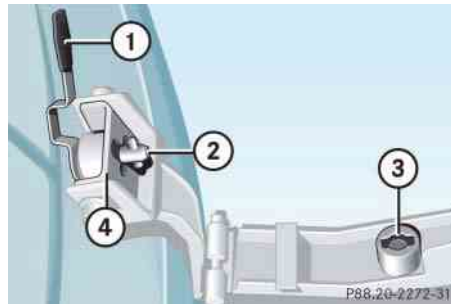

- ① Locking and unlocking handle
- ② Quick lock
- ③ Lock
- ④ End stop joint

**Lowering**

- ▶ While holding brush guard firmly, open quick lock ② using locking and unlocking handle ①.
- ▶ Gently lower brush guard until it reaches its fully lowered position.

**Raising and securing**

- ▶ Flip up brush guard until it contacts end stop joint ④.

Quick lock stop pin ② must engage the cross slot recess in lock ③.

- ▶ Now turn quick lock ② so that quick lock makes contact with end stop joint ④.
- ▶ Lock quick lock ② on both sides of brush guard using locking and unlocking handle ①.

**!** Make sure both quick stop pins ② are seated fully in lock ③.



### Replacing SmartKey batteries

If the batteries in the SmartKey are discharged, the vehicle can no longer be locked or unlocked. It is recommended to have the batteries replaced at an authorized Mercedes-Benz Light Truck Center.

#### Warning!



Keep the batteries out of reach of children.  
If a battery is swallowed, seek medical help immediately.

Batteries contain materials that can harm the environment if disposed of improperly. Recycling of batteries is the preferred method of disposal. Many states require sellers of batteries to accept old batteries for recycling.

**i** When inserting the batteries, make sure they are clean and free of lint.

**i** When replacing batteries, always replace both batteries.

The required replacement batteries are available at any Mercedes-Benz Light Truck Center.

Replacement batteries: Lithium, type CR 2025 or equivalent.

- ▶ Remove the mechanical key from the SmartKey (▷ page 370).

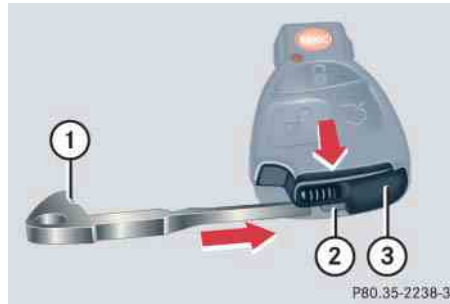

- ① Mechanical key
- ② Slide
- ③ Battery compartment

- ▶ Insert mechanical key ① in direction of the arrow in side opening.
- ▶ Using mechanical key ①, push gray slide ② to unlatch battery compartment ③.
- ▶ Pull battery compartment ③ out of the housing in direction of the arrow.

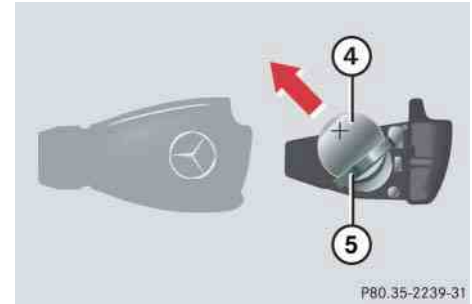

- ④ Battery
- ⑤ Contact spring

- ▶ Remove discharged batteries ④ in direction of the arrow.
- ▶ Using a lint-free cloth, insert new batteries under contact spring ⑤ with the positive terminal (+) facing up.
- ▶ Return battery compartment ③ into the housing until it locks into place.
- ▶ Slide mechanical key ① back into the SmartKey.
- ▶ Check the operation of the SmartKey.

## ▼ Replacing bulbs

### Bulbs

---

Safe vehicle operation depends on proper exterior lighting and signaling. It is therefore essential that all bulbs and lamp assemblies are in good working order at all times.

Correct headlamp adjustment is extremely important. Have headlamps checked and readjusted at regular intervals and when a bulb has been replaced. See an authorized Mercedes-Benz Light Truck Center for headlamp adjustment.

**i** *If the headlamps or front fog lamps are fogged up on the inside as a result of high humidity, driving the vehicle a distance with the lights on should clear up the fogging.*

**i** *Substitute bulbs will be brought into use when the following lamps malfunction:*

- *Turn signal lamps*
- *Tail lamps*
- *Parking lamps*
- *Rear fog lamp*

*Read and observe the messages in the multifunction display (▷ page 354).*

## Replacing bulbs



P54.00-2618-31

### Front lamps

| Lamp   | Type  |
|--|---|
| ① Additional turn signal lamp                          | LED   |
| ② Locator lighting lamp                                | W 6 W   |
| ③ Turn signal lamp                                     | 1 156 NA  |
| ④ Side marker lamp                                     | T 4 W   |
| ⑤ Bi-Xenon headlamp:<br>Low and high beam <sup>1</sup> | D 1S-35 W   |
|  | Parking and standing lamp<br>W 5 W<br>Blue vision |
| ⑥ Front fog lamp                                       | H 11 (55 W)                                       |

<sup>1</sup> Bi-Xenon headlamp: Low beam and high beam use the same D1S-35 W lamp. Do not replace the Bi-Xenon bulbs yourself. Contact an authorized Mercedes-Benz Light Truck Center.

### Rear lamps

| Lamp   | Type     |
|--|----------|
| ⑦ High mounted brake lamp  | LED      |
| ⑧ Turn signal lamp<br>Brake and tail lamp<br>Tail, parking and standing lamp | PY 21 W  |
|  | P 21/5 W |
|  | W 5 W    |
| ⑨ Backup lamp  | P 21 W   |
| ⑩ License plate lamps  | C 5 W    |
| ⑪ Rear fog lamp  | P 21 W   |
| ⑫ Side marker lamp   | T 4 W    |

**Warning!**

Bulbs and bulb sockets can be very hot. Allow the lamp to cool down before changing a bulb.

Keep bulbs out of reach of children.

Halogen lamps contain pressurized gas. A bulb can explode if you:

- touch or move it when hot
- drop the bulb
- scratch the bulb

Wear eye and hand protection.

Because of high voltage in Xenon lamps, it is dangerous to replace the bulb or repair the lamp and its components. We recommend that you have such work done by a qualified technician.

**Notes on bulb replacement**

- Only use 12-volt bulbs of the same type and with the specified watt rating.
- Switch lights off before changing a bulb to prevent short circuits.
- Always use a clean lint-free cloth when handling bulbs.
- Your hands should be dry and free of oil and grease.
- If the newly installed bulb does not come on, contact an authorized Mercedes-Benz Light Truck Center.

Have the LEDs and bulbs for the following lamps replaced at an authorized Mercedes-Benz Light Truck Center:

- the additional turn signal lamps in the exterior rear view mirrors
- the high mounted brake lamp
- the Bi-Xenon lamps
- the locator lighting lamps in the exterior rear view mirrors

**!** *Do not replace the LEDs yourself. You could otherwise damage the LEDs or parts of the vehicle. Only have the LEDs replaced at an authorized Mercedes-Benz Light Truck Center.*

### Replacing bulbs

#### Replacing bulbs for front lamps

**i** G 55 AMG (U.S. vehicles only):  
Fold the brush guard down before replacing bulbs (▷ page 375).

G 55 AMG:  
Remove the protective grille before replacing the bulbs.

Before you start to replace a bulb for a front lamp, do the following first:

- ▶ Turn the exterior lamp switch to position **0** (▷ page 117).

#### Bi-Xenon headlamp

##### Warning!



Do not remove the low beam/high beam cover for the Bi-Xenon headlamp. Because of high voltage in Xenon lamps, it is dangerous to replace the bulb or repair the lamp and its components. We recommend that you have such work done by a qualified technician.

#### Parking and standing lamp bulb



##### Left headlamp shown, right headlamp laterally reversed

- ① Securing screw (trim panel)
- ② Headlamp trim panel
- ▶ Loosen and remove securing screws ①.
- ▶ Remove headlamp trim panel ② in direction of arrow and the seal.

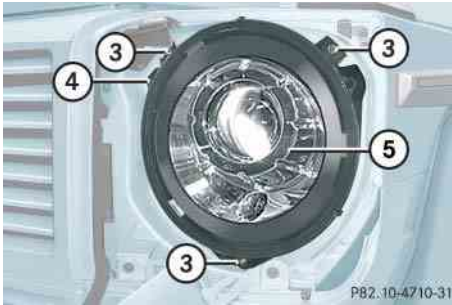

**Left headlamp shown, right headlamp laterally reversed**

- ③ Securing screw (headlamp)
- ④ Adjusting screw (headlamp)
- ⑤ Headlamp

▶ Loosen and remove headlamp-securing screws ③.

**i** Do not turn adjusting screw ④. If adjusting screw ④ is turned, the headlamp adjustment must be checked at a Mercedes-Benz Light Truck Center.

▶ Remove headlamp ⑤.

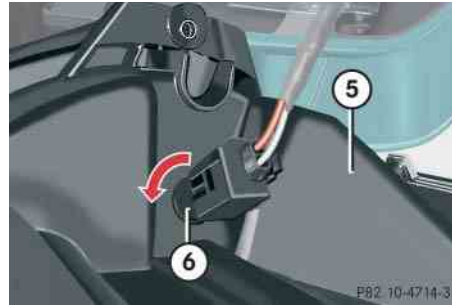

- ⑤ Headlamp
- ⑥ Bulb socket

- ▶ Hold headlamp ⑤, push gently onto bulb socket ⑥, and turn bulb socket ⑥ counterclockwise to its stop.
- ▶ Pull bulb socket ⑥ out of headlamp ⑤.

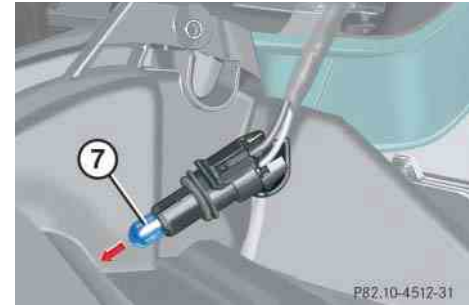

- ⑦ Bulb

- ▶ Pull bulb ⑦ out of its bulb socket.
- ▶ Insert the new bulb into the bulb socket.
- ▶ Hold headlamp ⑤, insert bulb socket ⑥ into headlamp ⑤, and turn bulb socket ⑥ clockwise to its stop.
- ▶ Insert headlamp ⑤ and install and tighten headlamp-securing screws ③.
- ▶ Install headlamp trim panel ② and the seal.
- ▶ Install and tighten securing screws ①.

## Replacing bulbs

### Front fog lamp bulb

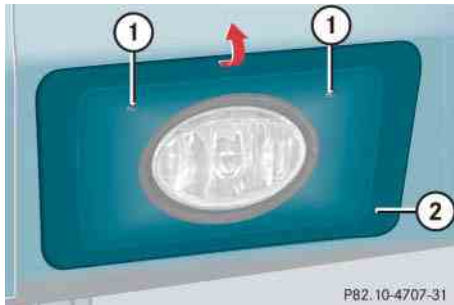

### Right front fog lamp shown, left front fog lamp laterally reversed

- ① Securing screw (trim panel)
- ② Front fog lamp trim panel

- ▶ Loosen and remove securing screws ①.
- ▶ Remove front fog lamp trim panel ② in direction of arrow and the seal.

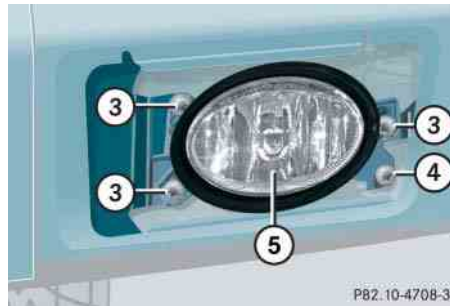

### Right front fog lamp shown, left front fog lamp laterally reversed

- ③ Securing screw (front fog lamp)
- ④ Adjusting screw (front fog lamp)
- ⑤ Front fog lamp

- ▶ Loosen and remove front fog lamp-securing screws ③.

**i** Do not turn adjusting screw ④. If adjusting screw ④ is turned, the front fog lamp adjustment must be checked at a Mercedes-Benz Light Truck Center.

- ▶ Remove front fog lamp ⑤.

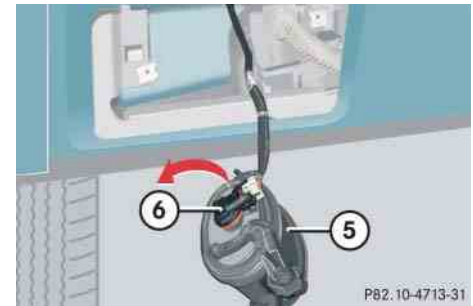

- ⑤ Front fog lamp
- ⑥ Bulb socket

- ▶ Hold front fog lamp ⑤, push gently onto bulb socket ⑥, and turn bulb socket ⑥ counterclockwise to its stop.
- ▶ Pull bulb socket ⑥ out of front fog lamp ⑤.

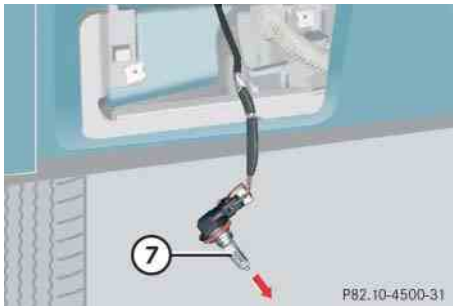

⑦ Bulb

- ▶ Pull bulb ⑦ out of its bulb socket.
- ▶ Insert the new bulb into the bulb socket.
- ▶ Hold front fog lamp ⑤, insert bulb socket ⑥ into front fog lamp ⑤, and turn bulb socket ⑥ clockwise to its stop.
- ▶ Insert front fog lamp ⑤ and install and tighten front fog lamp-securing screws ③.
- ▶ Install front fog lamp trim panel ② and the seal.
- ▶ Install and tighten securing screws ①.

Front turn signal lamp bulb

**i** G 55 AMG:  
Remove the protective grille before replacing the bulbs.



- ① Securing screw
- ② Turn signal lens
- ▶ Loosen and remove securing screws ①.
- ▶ Remove turn signal lens ②.

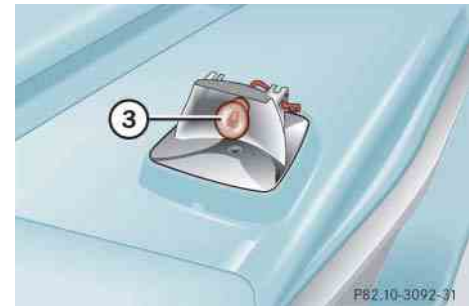

③ Bulb

- ▶ Press bulb ③ gently into the socket, turn counterclockwise and remove it.
- ▶ Press the new bulb gently into the socket and turn clockwise until it engages.
- ▶ Reinstall turn signal lens ②.
- ▶ Install and tighten securing screws ①.

**i** Do not overtighten securing screws ①. Otherwise turn signal lens ② could be damaged.



### Replacing bulbs

#### Side marker lamp bulb

The following description applies to both, the front and the rear side marker lamps.

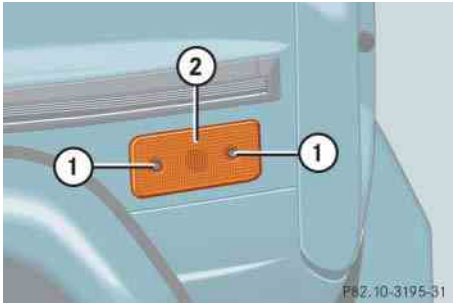

#### Front side marker shown

- ① Securing screw
- ② Side marker lamp housing
- ▶ Loosen and remove securing screws ①.
- ▶ Remove side marker lamp housing ②.

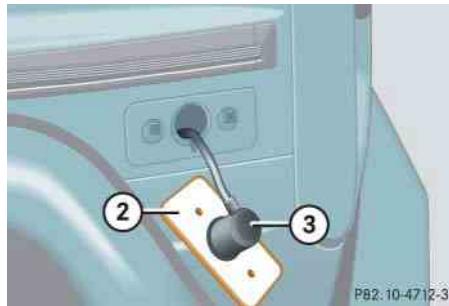

- ② Side marker lamp housing
- ③ Dust cover

- ▶ Remove dust cover ③.
- ▶ Press catch aside and pull out the bulb socket with the bulb from side marker lamp housing ②.



- ④ Bulb

- ▶ Press gently onto bulb ④ and turn counterclockwise out of its bulb socket.
- ▶ Press the new bulb gently into the bulb socket and turn clockwise until it engages.
- ▶ Insert the bulb socket back into side marker lamp housing ②.
- ▶ Reinstall dust cover ③.

▶ Reinstall side marker lamp housing ②.

▶ Install and tighten securing screws ①.

**i** Do not overtighten securing screws ①. Otherwise side marker lamp housing ② could be damaged.

### Additional turn signal lamps

The additional turn signal lamps in the exterior rear view mirrors have LEDs.

If a malfunction occurs or LEDs fail to function, the entire turn signal unit must be replaced. Have the turn signal unit replaced at an authorized Mercedes-Benz Light Truck Center.

### Locator lighting lamps

The locator lighting lamps in the exterior rear view mirrors have bulbs.

Have the bulbs replaced at an authorized Mercedes-Benz Light Truck Center.

### Replacing bulbs for rear lamps

Before you start to replace a bulb for a rear lamp, do the following first:

▶ Turn the exterior lamp switch to position **0** (▷ page 117).

### Bulbs in tail lamp unit

**i** G 55 AMG: Remove the protective grille before replacing the bulbs.

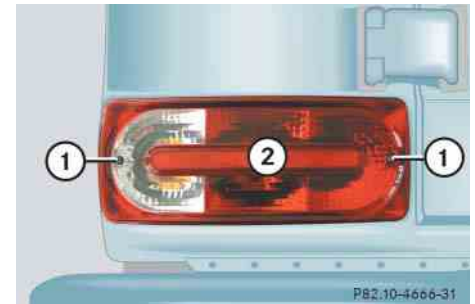

Left tail lamp lens shown, right tail lamp lens laterally reversed

① Securing screw

② Tail lamp lens

▶ Loosen and remove securing screws ①.

▶ Remove tail lamp lens ②.



### Replacing bulbs



**Left tail lamp unit shown, right tail lamp unit laterally reversed**

- ③ Turn signal lamp bulb
- ④ Brake, tail, parking and standing lamp bulb
- ⑤ Tail, parking and standing lamp bulb
- ▶ Press gently onto respective bulb ③, ④, or ⑤ and turn counterclockwise out of its bulb socket.
- ▶ Press the new bulb gently into the bulb socket and turn clockwise until it engages.
- ▶ Reinstall tail lamp lens ②.
- ▶ Install and tighten securing screws ①.

**i** Do not overtighten securing screws ①. Otherwise tail lamp lens ② could be damaged.

#### Rear fog lamp bulb/Backup lamp bulb

The following description applies to both, the rear fog lamp and the backup lamp.

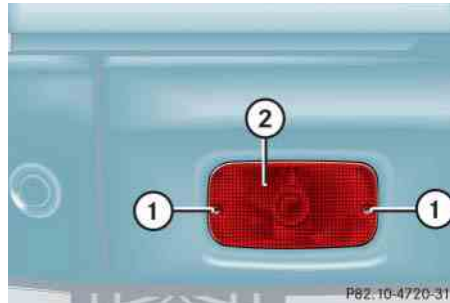

#### Rear fog lamp shown

- ① Securing screw
- ② Lamp lens
- ▶ Loosen and remove securing screws ①.
- ▶ Remove lamp lens ②.



#### ③ Bulb

- ▶ Press gently onto bulb ③ and turn counterclockwise out of its bulb socket.
- ▶ Press the new bulb gently into the bulb socket and turn clockwise until it engages.
- ▶ Reinstall lamp lens ②.
- ▶ Install and tighten securing screws ①.

**i** Do not overtighten securing screws ①. Otherwise lamp lens ② could be damaged.

### License plate lamp bulb



- ① Securing screw
- ② License plate lamp lens (with bulb socket)
- ▶ Loosen and remove securing screws ①.
- ▶ Remove license plate lamp lens ②.

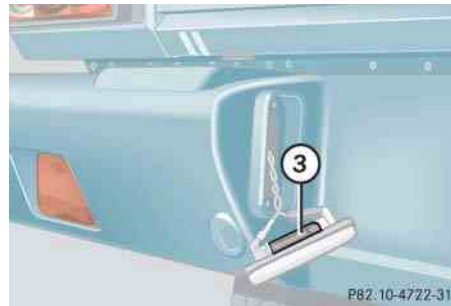

- ③ Tubular bulb
- ▶ Replace tubular bulb ③.
- ▶ Reinstall license plate lamp lens ②.
- ▶ Install and tighten securing screws ①.
- i** Do not overtighten securing screws ①. Otherwise license plate lamp lens ② could be damaged.

### High mounted brake lamp

The high mounted brake lamp has LEDs. If a malfunction occurs or LEDs fail to function, the brake lamp unit must be replaced. Have the brake lamp unit replaced at an authorized Mercedes-Benz Light Truck Center.

### Replacing wiper blades

#### Warning!



For safety reasons, switch off wipers and remove SmartKey from starter switch before replacing a wiper blade. Otherwise, the wiper motor could suddenly turn on and cause injury.

#### Warning!



Wiper blades are components that are subject to wear and tear. Replace the wiper blades twice a year, preferably in the spring and fall. Otherwise the windows will not be properly wiped. As a result, you may not be able to observe surrounding traffic conditions and could cause an accident.

#### Wiper blades

**!** Never open the hood when the wiper arm is folded forward.

*Hold on to the wiper when folding the wiper arm back. If released, the force of the impact from the tensioning spring could crack the windshield.*

*Do not allow the wiper arms to contact the windshield glass without a wiper blade inserted.*

*For your convenience, you should have this work carried out at an authorized Mercedes-Benz Light Truck Center.*

- ▶ Remove the SmartKey from the starter switch.

#### Removing

**!** Do not pull on the wiper blade inserts. They could tear.

- ▶ Fold the wiper arms forward until they engage.

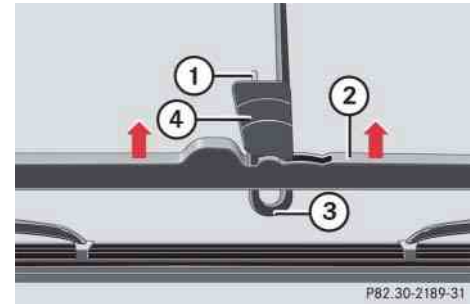

- ① Safety tab
- ② Wiper blade
- ③ Wiper arm
- ④ Attachment link

Replacing wiper blades

- ▶ Turn wiper blade ② at a right angle to wiper arm ③.
- ▶ Press safety tab ① of attachment link ④ down and slide wiper blade ② from the end of wiper arm ③.
- ▶ Remove wiper blade ②.

Installing

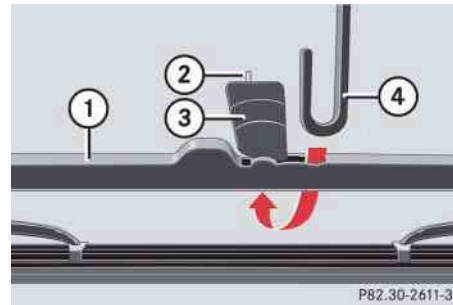

- ① Wiper blade
- ② Safety tab
- ③ Attachment link
- ④ Wiper arm

- ▶ Guide wiper blade ① so that opening goes through wiper arm ④.
- ▶ Press wiper blade ① into arch of wiper arm ④ until safety tab ② engages in attachment link ③.
- ▶ Fold the wiper arm back to rest on the windshield.

**!** Make sure the wiper blades are properly installed. Improperly installed wiper blades may cause windshield damage.

### Flat tire

When you replace the vehicle's tires, you can use the spare wheel as a regular wheel if:

- it is not more than 6 years old
- rim and tire are the same model as the regular wheels

#### Warning!



If the spare tire is more than 6 years old or is not the same model as the regular tires, have the spare tire replaced with a new tire at the nearest Mercedes-Benz Light Truck Center.

Never operate the vehicle with more than one spare wheel mounted.

#### Warning!



G 55 AMG:

Vehicles with different tire dimensions on the front and rear axle: rim and tire size of spare wheel and regular wheel differ. Handling will be adversely affected when the spare wheel is used.

Do not exceed the maximum speed of 50 mph (80 km/h).

### Preparing the vehicle

- ▶ Park the vehicle in a safe distance from moving traffic on a hard, flat surface when possible.
- ▶ Turn on the hazard warning flasher (▷ page 124).
- ▶ Turn the steering wheel so that the front wheels are in a straight-ahead position.
- ▶ Set the parking brake (▷ page 62).
- ▶ Move the gear selector lever to park position **P** (▷ page 162).
- ▶ Turn off the engine (▷ page 64).
- ▶ Remove the SmartKey from the starter switch.
- ▶ Have any passenger exit the vehicle at a safe distance from the roadway.

 *Open door only when conditions are safe to do so.*

## Mounting the spare wheel

### Preparing the vehicle

- ▶ Prepare the vehicle as described (▷ page 390).

#### Warning!



For your safety, remove spare wheel from spare wheel carrier before undertaking any further steps.

- ▶ Remove the spare wheel from the spare wheel carrier (▷ page 368).
- ▶ Take the vehicle tool kit out of its storage compartment (▷ page 366).
- ▶ Take the vehicle jack out of its storage compartment (▷ page 367).

### Lifting the vehicle

#### Warning!



The jack is designed exclusively for jacking up the vehicle under the axle housing. To help avoid personal injury, use the jack only to lift the vehicle during a wheel change. Never get beneath the vehicle while it is supported by the jack. Keep hands and feet away from the area under the lifted vehicle. Always firmly set parking brake and block wheels before raising vehicle with jack.

Do not disengage parking brake while the vehicle is raised. Be certain that the jack is always vertical (plumb line) when in use, especially on hills. Always try to use the jack on level surface.

Make sure the jack is positioned correctly under the axle housing. Always lower the vehicle onto sufficient capacity jackstands before working under the vehicle.

If the vehicle is not raised as described, it could slip off the jack as a result of vibrations (e.g. opening or closing a door or the tailgate).

- ▶ Prevent the vehicle from rolling away by blocking wheels with wheel chocks (not included) or other sizeable objects.

When changing wheel on a level surface:

- ▶ Place one wheel chock in front of and one behind the wheel that is diagonally opposite to the wheel being changed.

Always try lifting the vehicle using the jack on a level surface. However, should circumstances require you to do so on a hill, place the wheel chocks as follows:

- ▶ Place the wheel chocks on the downhill side blocking both wheels of the axle not being worked on.





### Flat tire



#### Wheel wrench

- ▶ Take the wheel wrench out of the vehicle tool kit.
- ▶ On wheel to be changed, loosen but do not yet remove the wheel bolts (approximately one full turn with the wheel wrench).

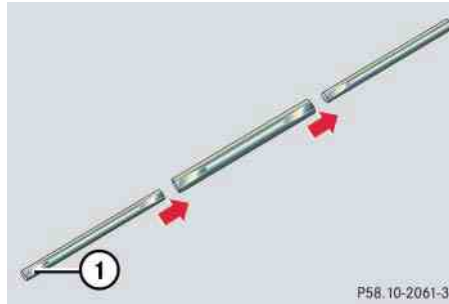

#### Pump handle (three pieces)

- ① Indent for activation of release bolt ②
- ▶ Take the pump handle out of the vehicle tool kit.
- ▶ Assemble the pump handle for the jack.

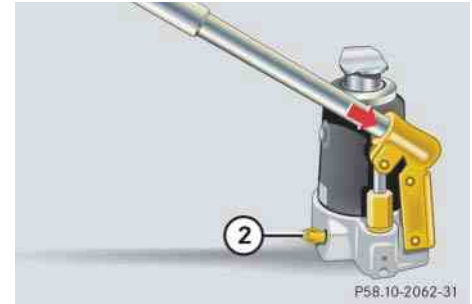

#### Jack

- ② Release bolt
- ▶ Set indent ① of the pump handle onto release bolt ②.
- ▶ Using the pump handle, turn release bolt ② clockwise until its stop. Release bolt ② is closed.
- ▶ Remove the pump handle from release bolt ②.
- ▶ Set the pump handle into the pump lever (indicated by the arrow).

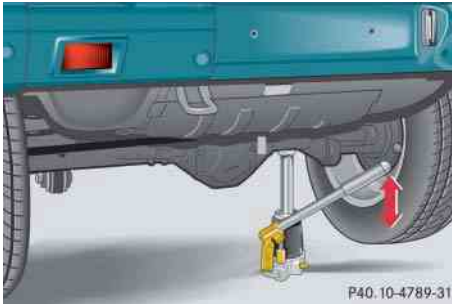

- ▶ Place jack on firm ground.

**!** Do not position the jack on the body of the vehicle, as this may cause damage to the vehicle.

- ▶ Position jack under the axle housing, so that it is always vertical (plumb-line) as seen from the side, even if the vehicle is parked on an incline.

Be certain the jack arm is positioned correctly under the axle housing (axle must fall into jack contour).

- ▶ Jack up the vehicle by pumping (indicated by the arrow) until the wheel is a maximum of 1.2 in (3 cm) from the ground.

**Warning!**



The jack is intended only for lifting the vehicle briefly for wheel changes. It is not suited for performing maintenance work under the vehicle.

- Never start the engine when the vehicle is raised.
- Never lie down under the raised vehicle.

**Removing the wheel**

- ▶ Remove the wheel bolts.

**!** Do not place wheel bolts in sand or dirt. This could result in damage to the bolt and wheel hub threads.

- ▶ Remove the wheel.

**Warning!**



Make sure no one is injured when removing the wheel.

Grip wheel from the sides.  
Keep hands from beneath the wheel.

### Flat tire

#### Mounting the new wheel

- ▶ Clean contact surfaces of wheel and wheel hub.

**!** *To avoid paint damage, place wheel flat against hub and hold it there while installing first wheel bolt.*

#### Warning!



Always replace wheel bolts that are damaged or rusted.

Never apply oil or grease to wheel bolts.

Damaged wheel hub threads should be repaired immediately. Do not continue to drive under these circumstances! Contact an authorized Mercedes-Benz Light Truck Center.

Incorrect wheel bolts or improperly tightened wheel bolts can cause the wheel to come off. This could cause an accident. Make sure to use the correct wheel bolts.

- ▶ Push the wheel onto the wheel hub and press firmly.
- ▶ Insert wheel bolts and tighten them slightly.

#### Warning!



Only use genuine Mercedes-Benz wheel bolts. Other wheel bolts may come loose.

Do not tighten the wheel bolts when the vehicle is raised. Otherwise the vehicle could tip over.

#### Lowering the vehicle

- ▶ Using the pump handle, turn the release bolt of the jack counter-clockwise approximately one turn (▷ page 392).

**i** *Never turn the release bolt of the jack more than one or two revolutions. Otherwise hydraulic fluid can escape.*

- ▶ Lower the vehicle until it is resting fully on its own weight.
- ▶ Remove the jack.

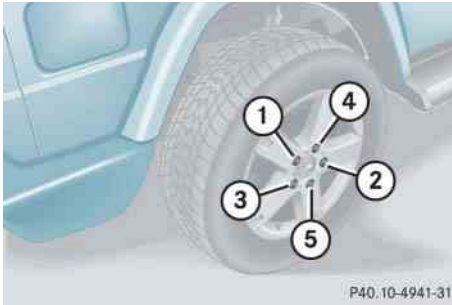

① - ⑤ Wheel bolts

- ▶ Tighten the five wheel bolts evenly, following the diagonal sequence illustrated (① to ⑤), until all wheel bolts are tight. Observe a tightening torque of 96 lb-ft (130 Nm).

**Warning!**



Have the tightening torque checked after changing a wheel. The wheels could come loose if they are not tightened to a torque of 96 lb-ft (130 Nm).

- ▶ Disassemble the pump handle (▷ page 392).
- ▶ Put the pump handle and the wheel wrench back into the vehicle tool kit.
- ▶ Store the vehicle tool kit in the designated storage compartment (▷ page 366).

- ▶ Press the jack piston in again and close the lowering screw (▷ page 392).
- ▶ Store the jack in the designated storage compartment (▷ page 367).
- ▶ After changing the wheel, secure the damaged wheel on the spare wheel carrier (▷ page 369). Make sure the wheel cannot come loose.
- ▶ Check the tire inflation pressure and correct it if necessary.

Follow recommended cold tire inflation pressures listed on the Tire and Loading Information placard on the driver's door B-pillar (▷ page 280).

### Battery

The battery is located in front of the rear seat bench and below the cup holder.

**i** Mercedes-Benz recommends to have the battery replaced at an authorized Mercedes-Benz Light Truck Center.

Jump starting terminals are located on the driver's side of the engine compartment (▷ page 400).

The battery should always be sufficiently charged in order to achieve its rated service life. Refer to Maintenance Booklet for battery maintenance intervals.

If you use your vehicle mostly for short-distance trips, you will need to have the battery charge checked more frequently.

When replacing the battery, always use batteries approved by Mercedes-Benz.

If you do not intend to operate your vehicle for an extended period of time, consult an authorized Mercedes-Benz Light Truck Center about steps you need to observe.

#### Warning!



Observe all safety instructions and precautions when handling automotive batteries.



Risk of explosion.



Fire, open flames and smoking are prohibited when handling batteries. Avoid creating sparks.



Battery acid is caustic. Do not allow it to come into contact with skin, eyes or clothing.

Wear suitable protective clothing, especially gloves, apron and faceguard.



Wear eye protection.  
Rinse any acid spills immediately with clear water. Contact a physician if necessary.



Keep children away.



Follow the instructions in this Operator's Manual.

Batteries contain materials that can harm the environment if disposed of improperly. Large 12-volt storage batteries contain lead. Recycling of batteries is the preferred method of disposal. Many states require sellers of batteries to accept old batteries for recycling.

**Warning!**

Failure to follow these instructions can result in severe injury or death.

Observe all safety instructions and precautions when handling automotive batteries (▷ page 396).

Never lean over batteries while connecting, you might get injured.

Battery fluid contains sulfuric acid. Do not allow this fluid to come in contact with eyes, skin or clothing. In case it does, immediately flush affected area with water and seek medical help if necessary.

A battery will also produce hydrogen gas, which is flammable and explosive. Keep flames or sparks away from battery, avoid improper connection of jumper cables, smoking, etc.

**Warning!**

Jump starting must only be done using the jump-start terminals located in the engine compartment (▷ page 400).

**Warning!**

Do not place metal objects on the battery as this could result in a short circuit.

Use leak-proof battery only to avoid the risk of acid burns in the event of an accident.

**!** Never loosen or detach battery terminal clamps while the engine is running or the SmartKey is in the starter switch. Otherwise the alternator and other electronic components could be severely damaged.

*Have the battery checked regularly at an authorized Mercedes-Benz Light Truck Center.*

*Refer to Maintenance Booklet for maintenance intervals or contact an authorized Mercedes-Benz Light Truck Center for further information.*

### Battery

#### Disconnecting, removing, reinstalling and reconnecting the battery

Disconnecting, removing, reinstalling and reconnecting the battery is a complicated and technically demanding procedure that also requires safety precautions to avoid the risk of injury. We strongly recommend that it should be performed by a qualified technician only. If it is necessary to work on the battery, contact a local authorized Mercedes-Benz Light Truck Center or call our Customer Assistance Center at 1-800-FOR-MERCEdes (1-800-367-6372).

**!** *Never invert the terminal connections!*

**!** *The battery, its filler caps and the vent tube must always be securely installed when the vehicle is in operation.*

#### Charging the battery

If the battery is discharged, the battery can be charged using the jump-start terminals located in the engine compartment (▷ page 400).

#### Warning!



Never charge a battery while still installed in the vehicle unless the accessory battery charge unit\* approved by Mercedes-Benz is being used. Gases may escape during charging and cause explosions that may result in paint damage, corrosion or personal injury.

An accessory battery charge unit\* specially adapted for Mercedes-Benz vehicles and tested and approved by Mercedes-Benz is available, permitting the charging of the battery in its installed position. Contact an authorized Mercedes-Benz Light Truck Center for information and availability. Charge battery in accordance with the separate instructions for the accessory battery charger\*.

**i** *With a discharged battery*

- *you will no longer be able to turn the SmartKey in the starter switch*
  - *the gear selector lever will remain locked in park position P*
- Charge the battery in accordance with the instructions of the battery charger manufacturer.

## ▼ Jump starting

### Warning!



Failure to follow these directions will cause damage to the electronic components, and can lead to a battery explosion and severe injury or death.

Never lean over batteries while connecting or jump starting, you might get injured.

Battery fluid contains sulfuric acid. Do not allow this fluid to come in contact with eyes, skin or clothing. In case it does, immediately flush affected area with water, and seek medical help if necessary.

A battery will also produce hydrogen gas, which is flammable and very explosive. Keep flames or sparks away from battery, avoid improper connection of jumper cables, smoking, etc.

Attempting to jump start a frozen battery can result in it exploding, causing personal injury.

Read all instructions before proceeding.

If the battery is discharged, the engine can be started with jumper cables and the battery of another vehicle. Observe the following:

- Jump starting should only be performed using the jump-start terminals located in the engine compartment (> page 400).
- Jump starting should only be performed when the engine and catalytic converter are cold.
- Do not start the engine if the battery is frozen. Let the battery thaw out first.
- Only jump start from batteries with the same voltage rating (12 V). Jump starting with a higher voltage battery could damage the vehicle's electrical system, which will not be covered by the Mercedes-Benz Limited Warranty.
- Only use jumper cables with sufficient cross-section and insulated terminal clamps.

- Always make sure the jumper cables are not on or near pulleys, fans, or other parts that move when an engine is started or running.

**!** Do not tow-start the vehicle.

**!** Avoid repeated and lengthy starting attempts.

*Do not attempt to start the engine using a battery quick charge unit.*

*If the engine does not run after several unsuccessful starting attempts, have it checked at the nearest authorized Mercedes-Benz Light Truck Center.*

*Excessive unburned fuel generated by repeated failed starting attempts may damage the catalytic converter.*

*Make sure the jumper cables do not have loose or missing insulation.*

*Make sure the cable clamps do not touch any other metal part while the other end is still attached to a battery.*



### Jump starting

#### Warning!



Keep flames or sparks away from battery.  
Do not smoke.

Observe all safety instructions and precautions when handling automotive batteries (▷ page 396).

- ▶ Make sure the two vehicles do not touch.
- ▶ Apply the parking brake (▷ page 62).
- ▶ Move the gear selector lever to park position **P**.
- ▶ Turn off all electrical consumers.
- ▶ Open the hood (▷ page 267).

The jump-start terminals are located on the driver's side of the engine compartment.

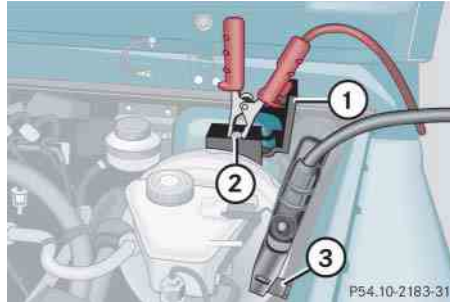

- ① Cover
- ② Positive (+) terminal
- ③ Negative (-) terminal

- ▶ Open cover ① of the positive terminal of both vehicles.

**!** *Never invert the terminal connections!*

- ▶ Connect positive terminal ② and the positive terminal of the charged battery with the jumper cable. Clamp the cable to the charged battery first.

- ▶ Start the engine of the vehicle with the charged battery and run at idle speed.
- ▶ Connect negative terminal ③ and the negative terminal of the charged battery with the jumper cable. Clamp the cable to the charged battery first.
- ▶ Start the engine of the disabled vehicle.

You can now turn on the electrical consumers. Do not switch on the headlamps under any circumstances.

- ▶ Remove the jumper cables first from the negative terminals on each battery and then from the positive terminals on each battery.

You can now switch on the headlamps.

- ▶ Have the battery checked at the nearest authorized Mercedes-Benz Light Truck Center.

## ▼ Towing the vehicle

Mercedes-Benz recommends that the vehicle be transported with all wheels off the ground using flatbed or appropriate wheel lift/dolly equipment. This method is preferable to other types of towing.

**!** Use flatbed or wheel lift/dolly equipment, with SmartKey in starter switch turned to position **0**.

*Do not tow with sling-type equipment. Towing with sling-type equipment over bumpy roads will damage radiator and supports.*

*To prevent damage during transport, do not tie down vehicle by its chassis or suspension parts. Use the towing eyes.*

*Switch off the ESP® (▷ page 94), the tow-away alarm (▷ page 98) and the automatic central locking (▷ page 155).*

**!** Do not tow-start the vehicle.

When circumstances do not permit the recommended towing methods, the vehicle may be towed with all wheels on the ground only so far as necessary to have the vehicle moved to a safe location where the recommended towing methods can be employed.

**!** *When towing the vehicle with all wheels on the ground, the gear selector lever must be in neutral position **N** and the SmartKey must be in starter switch position **2**.*

*When towing the vehicle with all wheels on the ground, the vehicle may be towed only for distances up to 30 miles (50 km) and at a speed not to exceed 30 mph (50 km/h).*

*If the vehicle is towed with one axle raised (observe instructions regarding flexible drive shaft and propeller shafts), the engine must be shut off and the SmartKey must be in starter switch position **1**. Otherwise, the 4-ETS may become engaged which may cause loss of towing control.*

### Warning!



If circumstances require towing the vehicle with all wheels on the ground, always tow with a tow bar if:

- the engine will not run
- there is a malfunction in the brake system
- there is a malfunction in the power supply or in the vehicle's electrical system

This is necessary to adequately control the towed vehicle.

Prior to towing the vehicle with all wheels on the ground, make sure the SmartKey is in starter switch position **2**.

If the SmartKey is left in the starter switch position **0** for an extended period of time, it can no longer be turned in the switch. In this case, the steering is locked. To unlock, remove SmartKey from starter switch and reinsert.

### Towing the vehicle

#### Warning!



With the engine not running, there is no power assistance for the brake and steering systems. In this case, it is important to keep in mind that a considerably higher degree of effort is necessary to brake and steer the vehicle. Adapt your driving accordingly.

**!** Towing of the vehicle should only be done using the towing eye. Never attach tow cable, tow rope or tow rod to vehicle chassis, frame or suspension parts.

**i** When towing the vehicle with all wheels on the ground, note the following:

*With the automatic central locking activated and the SmartKey in starter switch position **2**, the vehicle doors lock if a wheel is turning at vehicle speeds of approximately 9 mph (15 km/h) or above.*

*To prevent the vehicle doors from locking, deactivate the automatic central locking (▷ page 155).*

**i** To signal turns while being towed with hazard warning flasher in use, turn the SmartKey in starter switch to position **2** and activate combination switch for left or right turn signal in usual manner – only the selected turn signal will operate.

*Upon canceling the turn signal, the hazard warning flasher will operate again.*

**i** The gear selector lever will remain locked in park position **P** and the SmartKey will not turn in the starter switch if the battery is disconnected or discharged. For more information, see “Battery” (▷ page 396) and “Jump starting” (▷ page 399).

*For information on manually unlocking the gear selector lever, see (▷ page 373).*

## Transporting the vehicle

When transporting the vehicle, you can use the towing eyes for pulling the vehicle onto a trailer or transporter.

- ▶ Move the gear selector lever to neutral position **N**.
- ▶ Shift the transfer case to neutral position **N**.
- ▶ To avoid damaging the vehicle, it should only be tied down on the wheels/wheel rims, not on chassis components such as the transverse link or trailing arm.

## Towing the vehicle - various problem scenarios

**!** *When removing drive shaft, place M10 nuts on bolts as distance sleeves and tighten using M8 nuts. Always install new self-locking nuts when reinstalling the drive shaft.*

- ▶ Comply with all towing information (▷ page 401).

## In case of engine damage, transmission damage or malfunctions in electrical equipment

- ▶ Move the gear selector lever to neutral position **N**.
- ▶ Shift the transfer case to neutral position **N**.

## In case of transfer case damage or for towing vehicle distances exceeding 30 miles (50 km)

The propeller shafts to the drive axles must be removed.

## In case of front axle damage

Raise the front axle when towing. The propeller shaft between the rear axle and the transfer case must be removed.

## In case of rear axle damage

When the rear axle is raised, the vehicle can only be towed with a wheel lift or a dolly placed under its front wheels.

### Towing the vehicle

#### Front towing eye

The front towing eye is located on the driver's side under the front bumper.

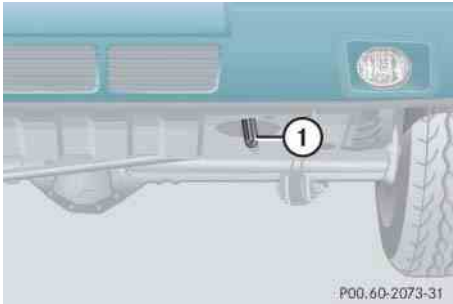

① Towing eye

#### Rear towing eye

The rear towing eye is located on the driver's side under the rear bumper.

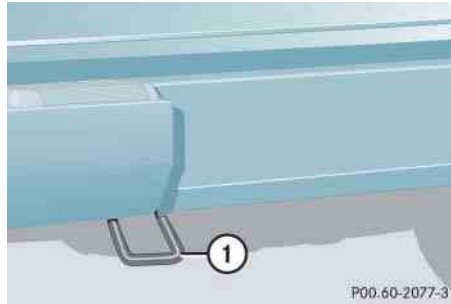

① Towing eye

#### Stranded vehicle

Freeing a stranded vehicle, on which the wheels are dug into sand or mud, should be done with the greatest of care, especially if the vehicle is heavily loaded.

Avoid pulling the vehicle jerkily or diagonally, since it could result in damage to the chassis alignment.

Never try to free a vehicle that is still coupled to a trailer.

If possible, a vehicle should be pulled backward in its own previously made tracks.

## ▼ Fuses

The electrical fuses in your vehicle serve to switch off malfunctioning power circuits.

If a fuse is blown, the components and systems secured by that fuse will stop operating.

### Warning!



Only use fuses approved by Mercedes-Benz with the specified amperage for the system in question and do not attempt to repair or bridge a blown fuse. Using other than approved fuses or using repaired or bridged fuses may cause an overload leading to a fire, and/or cause damage to electrical components and/or systems. Have the cause determined and remedied at an authorized Mercedes-Benz Light Truck Center.

**i** A blown fuse must be replaced by an appropriate spare fuse (recognizable by its color or the fuse rating given on the fuse) of the amperage recommended in the fuse chart. Any Mercedes-Light Truck Center will be glad to advise you on this subject.

If a newly inserted fuse blows again, have the cause determined and rectified at an authorized Mercedes-Benz Light Truck Center.

The following aids are available to help you replace fuses.

- Fuse chart

The fuse chart explains the fuse allocation and fuse amperages.

The fuse chart is located in the main fuse box in the passenger compartment (▷ page 406).

- Spare fuses

The spare fuses are located in the main fuse box in the passenger compartment (▷ page 406).

- Fuse extractor

The fuse extractor is located in the vehicle tool kit in the rear footwell (▷ page 366).

The electrical fuses are located in different fuse boxes:

- in the passenger compartment on the driver's side (▷ page 406)
- in the front passenger footwell (▷ page 406)
- in the middle tunnel (▷ page 407)
- in the battery box (▷ page 408)

Before replacing fuses:

- ▶ Apply parking brake (▷ page 62).
- ▶ Make sure the gear selector lever is set to park position **P** (▷ page 162).
- ▶ Turn off all electrical consumers.
- ▶ Turn off the engine (▷ page 64).
- ▶ Remove the SmartKey from the starter switch.

## Fuses

### Main fuse box in passenger compartment

- ▶ Open the driver's door.

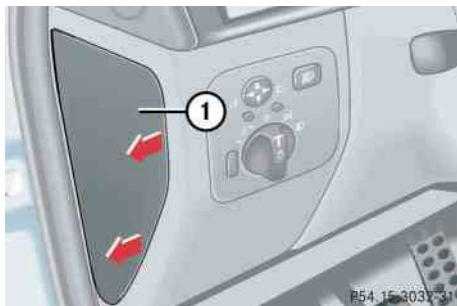

- ① Cover

**!** Do not use sharp objects such as a screw driver to open fuse box cover ① in the dashboard, as this could damage it.

- ▶ Remove cover ① in direction of the arrows.

### Fuse box in front passenger footwell

**i** We recommend having the fuses changed at a Mercedes-Benz Light Truck Center.

- ▶ Open the front passenger door.

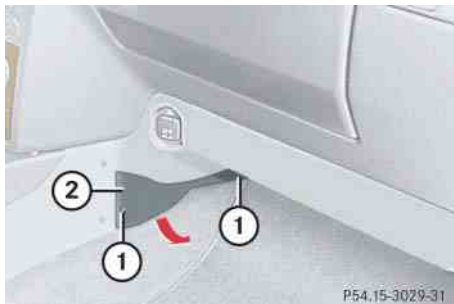

- ① Mounting screw
- ② Cover

- ▶ Unscrew mounting screws ①.
- ▶ Remove cover ② in direction of the arrow.

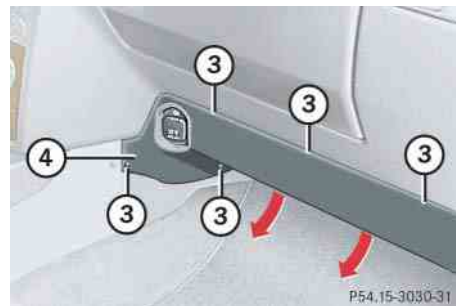

- ③ Mounting screw
- ④ Cover

- ▶ Unscrew mounting screws ③.
- ▶ Remove cover ④ in direction of the arrows.



- ⑤ Fuse box
- ⑥ Mounting screw

**i** To make changing the fuses easier, fuse box ⑤ can be folded down slightly.

- ▶ Unscrew mounting screws ⑥.
- ▶ Fold fuse box ⑤ downward in direction of the arrow.

### Fuse box in middle tunnel

**i** We recommend having the fuses changed at a Mercedes-Benz Light Truck Center.

### Removing front end stops

- ▶ Open the front passenger door.

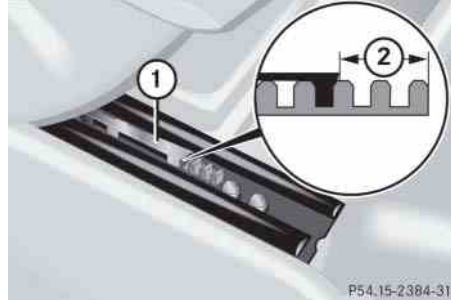

### Front end stop on the right seat rail, left seat rail laterally reversed

- ① Front end stop
- ② Spacing

- ▶ Remove both front end stops ① of the front passenger seat tracks using a screwdriver.
- ▶ Move front passenger seat fully forward.

**!** When reinstalling front passenger seat track stops, place end stops in correct position. For your safety, maintain proper spacing ②.

### Warning!



Do not drive the vehicle when the front end stops are not correctly installed. Failure to reinstall stops as indicated may result in serious injury in certain frontal crashes.

Adjust the front passenger seat as far as possible rearward from the dashboard when the seat is occupied. Comply with information on occupant safety (▷ page 68).



### Fuses

#### Opening fuse box

- ▶ Open the rear door on the passenger side.

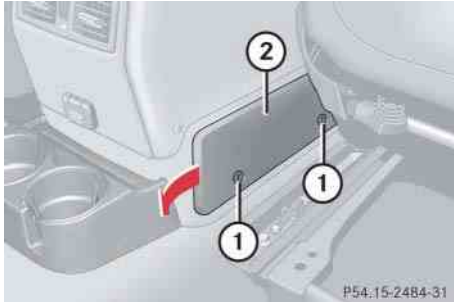

- ① Mounting screw
- ② Cover

- ▶ Unscrew mounting screws ①.
- ▶ Remove cover ② in direction of the arrow.

#### Fuse box in battery box

The battery box is located under a cover in the rear footwell.

Replacement of fuses can only be performed at a Mercedes-Benz Light Truck Center.



**Parts service**

**Warranty coverage**

**Identification labels**

**Layout of poly-V-belt drive**

**Engine**

**Rims and tires**

**Electrical system**

**Main dimensions, vehicle weights  
and ratings**

**Fuels, coolants, lubricants, etc.**

The “Technical data” section provides the necessary technical data for your vehicle.

All authorized Mercedes-Benz Light Truck Centers maintain a stock of Genuine Mercedes-Benz Parts required for maintenance and repair work. In addition, strategically located parts distribution centers provide quick and reliable parts service.

More than 300 000 different parts for Mercedes-Benz models are available.

Genuine Mercedes-Benz Parts are subjected to stringent quality inspections. Each part has been specifically developed, manufactured or selected for and adapted to Mercedes-Benz vehicles.

Therefore, Genuine Mercedes-Benz parts should be installed.

**!** *The use of non-genuine Mercedes-Benz parts and accessories not authorized by Mercedes-Benz could damage the vehicle, which is not covered by the Mercedes-Benz Limited Warranty, or could compromise the vehicle's durability or safety.*

## ▼ Warranty coverage

Your vehicle is covered under the terms of the warranties printed in the Service and Warranty Information booklet. Your authorized Mercedes-Benz Light Truck Center will exchange or repair any defective parts originally installed in the vehicle in accordance with the terms of the following warranties:

- New Vehicle Limited Warranty
- Emission System Warranty
- Emission Performance Warranty
- California, Maine, Massachusetts, and Vermont Emission Control Systems Warranty

Replacement parts and accessories are covered by the Mercedes-Benz Parts and Accessories warranties, copies of which are available at any Mercedes-Benz Light Truck Center.

## Loss of Service and Warranty Information Booklet

---

Should you lose your Service and Warranty Information booklet, have an authorized Mercedes-Benz Light Truck Center arrange for a replacement. It will be mailed to you.

## Identification labels

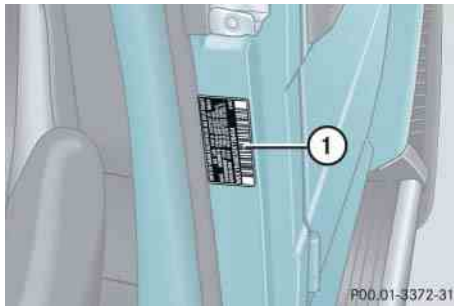

- ① Certification label (on driver's door B-pillar)

The Vehicle Identification Number (VIN) can be found in the following locations:

- on the certification label on the driver's door B-pillar (▷ page 412)
- embossed on the frame in the passenger side front wheelhouse (▷ page 413)
- on the lower edge of the windshield (▷ page 413)

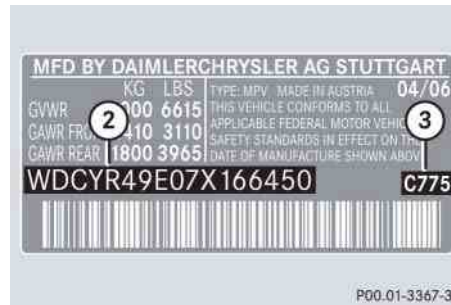

**Example certification label (U.S. vehicles)**

- ② VIN  
③ Paintwork code



**Example certification label (Canada vehicles)**

- ② VIN  
③ Paintwork code

**i** Data shown on certification label are for illustration purposes only. These data are specific to each vehicle and may vary from data shown in the illustration above. Refer to certification label on vehicle for actual data specific to your vehicle.

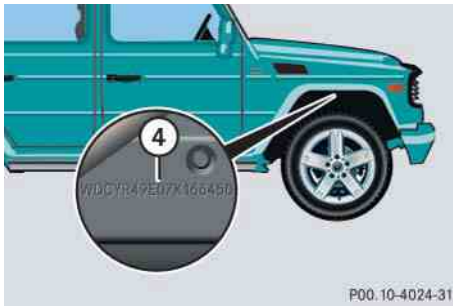

④ VIN (on frame in front wheel house)

P00.10-4024-31



⑤ VIN (on lower edge of windshield)

P00.10-4025-31

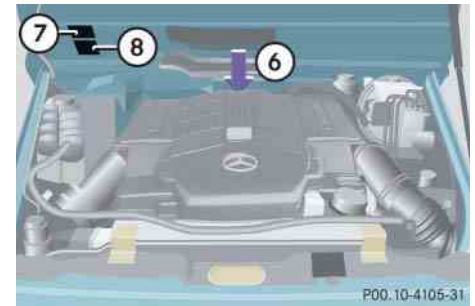

**Example illustration G 500**

P00.10-4105-31

- ⑥ Engine number (engraved on engine)
- ⑦ Emission control information label, includes both federal and California certification exhaust emission standards
- ⑧ Vacuum line routing diagram label

**i** When ordering parts, please specify vehicle identification and engine numbers.

## Layout of poly-V-belt drive

For dimensions of the poly-V-belt, see technical data (▷ page 415).

**G 500**

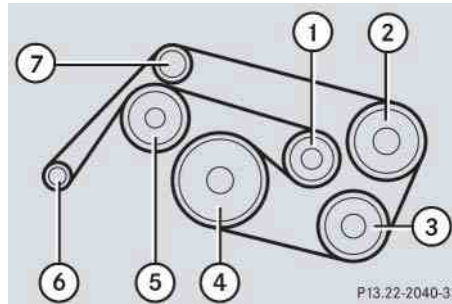

- ① Automatic belt tensioner
- ② Power steering pump
- ③ Air conditioning compressor
- ④ Crankshaft
- ⑤ Coolant pump
- ⑥ Generator (alternator)
- ⑦ Idler pulley

**G 55 AMG**

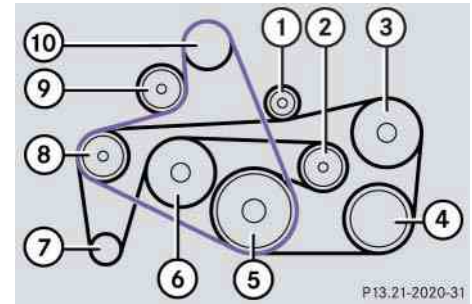

**The G 55 AMG has two poly-V-belts (belt one shown in purple/belt two shown in black).**

- ① Idler pulley
- ② Automatic belt tensioner
- ③ Power steering pump
- ④ Air conditioning compressor
- ⑤ Crankshaft
- ⑥ Coolant pump
- ⑦ Generator (alternator)
- ⑧ Idler pulley
- ⑨ Automatic belt tensioner
- ⑩ Supercharger

▼ Engine

| Model                             | G 500 (463.249) <sup>1</sup>                              | G 55 AMG (463.271) <sup>1</sup>                           |
|-----------------------------------|---|---|
| Engine                            | 113   | 113   |
| Mode of operation                 | 4-stroke engine, gasoline injection                       | 4-stroke engine, gasoline injection                       |
| No. of cylinders                  | 8   | 8   |
| Bore                              | 3.82 in (97.00 mm)  | 3.82 in (97.00 mm)  |
| Stroke                            | 3.31 in (84.00 mm)  | 3.60 in (92.00 mm)  |
| Total piston displacement         | 303.0 cu in (4966 cm <sup>3</sup> )                       | 331.8 cu in (5439 cm <sup>3</sup> )                       |
| Compression ratio                 | 10:1  | 9:1   |
| Output acc. to SAE J 1349         | 292 hp/5 500 rpm <sup>2</sup><br>(218 kW/5 500 rpm)       | 493 hp/6 100 rpm <sup>2</sup><br>(368 kW/6 100 rpm)       |
| Maximum torque acc. to SAE J 1349 | 336 lb-ft/2 800 - 4 000 rpm<br>(456 Nm/2 800 - 4 000 rpm) | 516 lb-ft/2 650 - 4 000 rpm<br>(700 Nm/2 650 - 4 000 rpm) |
| Maximum engine speed              | 6 300 rpm   | 6 500 rpm   |
| Firing order                      | 1-5-4-2-6-3-7-8   | 1-5-4-2-6-3-7-8   |
| Poly-V-belt                       | 2380 mm   | Belt one: 1289 mm<br>Belt two: 2449 mm                    |

<sup>1</sup> The quoted data apply only to the standard vehicle. See an authorized Mercedes-Benz Light Truck Center for the corresponding data of all special bodies and special equipment.

<sup>2</sup> Premium fuel required. Performance may vary with fuel octane rating.



### Rims and tires

**!** Only use tires which have been tested and approved by Mercedes-Benz. Tires approved by Mercedes-Benz are developed to provide best possible performance in conjunction with the driving safety systems on your vehicle such as ABS or ESP®. Tires specially developed for your vehicle and tested and approved by Mercedes-Benz can be identified by finding the following on the tire's sidewall:

- MO = Mercedes-Benz Original equipment tires

Using tires other than those approved by Mercedes-Benz may result in damage that is not covered by the Mercedes-Benz Limited Warranty.

**!** Using tires other than those approved by Mercedes-Benz can have detrimental effects, such as

- poor handling characteristics
- increased noise
- increased fuel consumption

Moreover, tires and rims not approved by Mercedes-Benz may, under load, exhibit dimensional variations and different tire deformation characteristics that could cause them to come into contact with the vehicle body or axle parts. Damage to the tires or the vehicle may be the result.

**i** Further information on tires and rims is available at any authorized Mercedes-Benz Light Truck Center. The Tire and Loading Information placard with the recommended tire inflation pressures is located on the driver's door B-pillar. Some vehicles may have supplemental tire inflation pressure information for driving at high speeds (▷ page 287) or for vehicle loads less than the maximum loaded vehicle condition (▷ page 287). If such information is provided, it can be found on the tire inflation pressure label located on the inside of the fuel filler flap.

The tire inflation pressure should be checked regularly and should only be adjusted on cold tires. Follow tire manufacturer's maintenance recommendation included with vehicle.



**i** The following pages also list the approved wheel rim and tire sizes for equipping your vehicles with winter tires. Winter tires are not available as standard or optional factory equipment, but can be purchased from an authorized Mercedes-Benz Light Truck Center.

Depending on vehicle model and the standard or optional factory-equipped wheel rim/tire configuration on your vehicle, equipping your vehicle with winter tires approved for your vehicle model may also require the purchase of two or four wheel rims of the recommended size for use with these winter tires. See an authorized Mercedes-Benz Light Truck Center for more information.

Same size tires

|                                     |                     |
|-------------------------------------|---------------------|
| <b>Model</b>                        | <b>G 500</b>        |
| <b>Rims (light alloy)</b>           | 7.5 J x 18 H2       |
| <b>Wheel offset</b>                 | 1.69 in (43 mm)     |
| <b>All season tires<sup>1</sup></b> | 265/60 R18 110V M+S |

<sup>1</sup> Radial-ply tires

| <b>Model</b>                      | <b>G 55 AMG</b>  | <b>G 55 AMG</b> |
|-----------------------------------|--|-----------------|
| <b>Rims (light alloy)</b>         | 7.5 J x 18 H2  | 9.5 J x 18 EH2  |
| <b>Wheel offset</b>               | 1.69 in (43 mm)  | 1.97 in (50 mm) |
| <b>Summer tires<sup>1,2</sup></b> | -  | 285/55 R18 113V |
| <b>Winter tires<sup>1</sup></b>   | 265/60 R18 109H M+S <br>or<br>265/60 R18 110V M+S  | -               |

<sup>1</sup> Radial-ply tires

<sup>2</sup> Must not be used with snow chains.

**Rims and tires****Spare wheel**

---

| <b>Model</b>                       | <b>G 500</b>        | <b>G 55 AMG</b>     |
|------------------------------------|---------------------|---------------------|
| <b>Rim (light alloy)</b>           | 7.5 J x 18 H2       | 7.5 J x 18 H2       |
| <b>Wheel offset</b>                | 1.69 in (43 mm)     | 1.69 in (43 mm)     |
| <b>All season tire<sup>1</sup></b> | 265/60 R18 110V M+S | 265/60 R18 110V M+S |

<sup>1</sup> Radial-ply tire

▼ Electrical system

| Model                  | G 500                                    | G 55 AMG                   |
|------------------------|--|----------------------------|
| Generator (alternator) | 14 V/150 A                               | 14 V/180 A                 |
| Starter motor          | 12 V/1.7 kW                              | 12 V/1.7 kW                |
| Battery                | 12 V/90 Ah                               | 12 V/90 Ah                 |
| Spark plugs            | Bosch F 8 DPER<br>Beru 14 FGH 8 DPUR X 2 | NGK ILFR6A                 |
| Electrode gap          | 0.039 in (1.0 mm)                        | 0.039 in (1.0 mm)          |
| Tightening torque      | 15 – 22 lb-ft (20 – 30 Nm)               | 15 – 22 lb-ft (20 – 30 Nm) |

### Main dimensions, vehicle weights and ratings

#### Main dimensions

| Model   | G 500              | G 55 AMG           |
|---|--------------------|--------------------|
| Overall vehicle length (inc. spare wheel)                               | 185.6 in (4715 mm) | 185.6 in (4715 mm) |
| Overall vehicle length (inc. spare wheel and brush guard <sup>1</sup> ) | -                  | 186.6 in (4740 mm) |
| Overall vehicle width (exterior rear view mirrors folded out)           | 78.9 in (2005 mm)  | 78.9 in (2005 mm)  |
| Overall vehicle width (exterior rear view mirrors folded in)            | 71.7 in (1821 mm)  | 73.0 in (1855 mm)  |
| Overall vehicle height  | 77.8 in (1977 mm)  | 77.8 in (1977 mm)  |
| Wheel base  | 112.2 in (2850 mm) | 112.2 in (2850 mm) |
| Track, front and rear   | 59.6 in (1515 mm)  | 59.1 in (1501 mm)  |
| Ground clearance  | 8.3 in (211 mm)    | 8.3 in (211 mm)    |
| Turning circle  | 43.6 ft (13.3 m)   | 43.6 ft (13.3 m)   |

<sup>1</sup> Brush guard is available on G 55 AMG (U.S. vehicles only).

Vehicle weights and ratings

| Model   | G 500              | G 55 AMG            |
|---|--------------------|---------------------|
| Gross Vehicle Weight Rating (GVWR) <sup>1</sup>     | 6 615 lb (3000 kg) | 6 615 lb (3000 kg)  |
| Gross Axle Weight Rating (GAWR), front <sup>2</sup> | 3 110 lb (1410 kg) | 3 200 lb (1 450 kg) |
| Gross Axle Weight Rating (GAWR), rear <sup>2</sup>  | 3 965 lb (1800 kg) | 3 965 lb (1 800 kg) |

<sup>1</sup> The GVWR is the maximum permissible vehicle weight. The Gross Vehicle Weight (GVW) comprises weight of vehicle including fuel, tools, spare wheel, installed accessories, passengers, cargo and, if applicable, trailer tongue load. The GVW must never exceed the GVWR.

<sup>2</sup> The GAWR is the maximum permissible axle weight.

### Fuels, coolants, lubricants, etc.

#### Capacities

---

Vehicle components and their respective lubricants must match. Therefore only use products tested and approved by Mercedes-Benz.

Please refer to the Factory Approved Service Products pamphlet (USA only), or inquire at an authorized Mercedes-Benz Light Truck Center.

#### Warning!



Comply with all valid regulations with respect to handling, storing and disposing of service fluids. Otherwise you could endanger persons or the environment.

Keep service fluids out of the reach of children.

For health reasons, you should prevent service fluids from coming into direct contact with your skin or clothing.

If a service fluid is swallowed, contact a physician immediately.

**Fuels, coolants, lubricants, etc.**

|                                    | Model    | Capacity                         | Fuels, coolants, lubricants, etc.                            |
|------------------------------------|----------|----------------------------------|--|
| <b>Engine with oil filter</b>      | G 500    | 8.5 US qt (8.0 l)                | Approved engine oils   |
|                                    | G 55 AMG | 9.0 US qt (8.5 l)                |  |
| <b>Automatic transmission</b>      |          | 9.0 US qt (8.5 l)                | MB Automatic Transmission Fluid                              |
| <b>Transfer case</b>               |          | 2.96 US qt (2.8 l)               | MB part no. A 001 989 28 03 10                               |
| <b>Differential lock mechanism</b> |          | 0.47 - 0.63 US qt (0.45 - 0.6 l) | Brake fluid DOT 3+4, SAE J 1703                              |
| <b>Front axle</b>                  | G 500    | 1.5 US qt (1.4 l)                | Hypoid gear oil SAE 85W-90<br>Hypoid gear oil Castrol SAF-XJ |
|                                    | G 55 AMG | 1.5 US qt (1.4 l)                |  |
| <b>Rear axle</b>                   | G 500    | 1.9 US qt (1.8 l)                | Hypoid gear oil SAE 85W-90<br>Hypoid gear oil Castrol SAF-XJ |
|                                    | G 55 AMG | 1.9 US qt (1.8 l)                |  |
| <b>Power steering</b>              |          | approx. 1.06 US qt (1.0 l)       | MB Power Steering Fluid, or approved Dexron III ATF          |
| <b>Front wheel hubs</b>            |          | approx. 1.5 oz (43 g) each       | High temperature roller bearing grease                       |
| <b>Brake system</b>                |          | 0.86 US qt (0.8 l)               | MB Brake Fluid (DOT 4+)                                      |



### Fuels, coolants, lubricants, etc.

|  | Model             | Capacity  | Fuels, coolants, lubricants, etc.   |
|--|-------------------|---|---|
| <b>Fuel tank</b><br><br><b>including a reserve of</b>                        | G 500<br>G 55 AMG | 25.4 US gal (96.0 l)<br>25.1 US gal (95.0 l)<br><br>approx. 3.4 US gal (13.0 l) | Premium unleaded gasoline:<br>Minimum Posted Octane 91<br>(Avg. of 96 RON/86 MON) |
| <b>Cooling system</b>  | G 500<br>G 55 AMG | approx. 12.7 US qt (12.0 l)<br>approx. 13.4 US qt (12.7 l)                      | MB 325.0 Anticorrosion/Antifreeze   |
| <b>Air conditioning system</b>   |                   |   | R-134a refrigerant and<br>special PAG lubricant oil (never R-12)                  |
| <b>Windshield/rear window washer system<br/>and headlamp cleaning system</b> |                   | approx. 7.9 US qt (7.5 l)   | MB Windshield Washer Concentrate <sup>1</sup>                                     |

<sup>1</sup> Use MB Windshield Washer Concentrate “MB SummerFit” and water for temperatures above freezing point or MB Windshield Washer Concentrate “MB SummerFit” and commercially available premixed windshield washer solvent/antifreeze for temperatures below freezing point. Follow suggested mixing ratios (> page 430).

## Engine oils

Engine oils are specifically tested for their suitability in our engines and durability for our service intervals. Therefore, only use approved engine oils and oil filters required for vehicles with Maintenance System (U.S. vehicles) or FSS (Canada vehicles). For a listing of approved engine oils and oil filters, refer to the Factory Approved Service Products pamphlet (USA only), or contact an authorized Mercedes-Benz Light Truck Center.

**!** *Using engine oils and oil filters of specification other than those expressly required for the Maintenance System (U.S. vehicles) or FSS (Canada vehicles), or changing of oil and oil filter at change intervals longer than those called for by the Maintenance System (U.S. vehicles) or FSS (Canada vehicles) will result in engine damage not covered by the Mercedes-Benz Limited Warranty.*

*Please follow Maintenance System (U.S. vehicles) or FSS (Canada vehicles) recommendations for scheduled oil changes. Failure to do so will result in engine damage not covered by the Mercedes-Benz Limited Warranty.*

## Engine oil additives

**!** *Do not blend oil additives with engine oil. They may damage the engine. Damage or malfunctions resulting from blending oil additives are not covered by the Mercedes-Benz Limited Warranty.*

## Air conditioning refrigerant

R-134a (HFC) refrigerant and special PAG lubricating oil are used in the air conditioning system.

**!** *Never use R-12 (CFC) or mineral-based lubricating oil. Otherwise damage to the system will occur.*

## Brake fluid

### Warning!



During vehicle operation, the boiling point of the brake fluid is continuously reduced through the absorption of moisture from the atmosphere. Under extremely strenuous operating conditions, this moisture content can lead to the formation of bubbles in the system, thus reducing the system's efficiency.

Therefore, the brake fluid must be replaced regularly. Refer to your vehicle's Maintenance Booklet for replacement interval.

Only brake fluid approved by Mercedes-Benz is recommended. Any authorized Mercedes-Benz Light Truck Center will provide you with additional information.

### Fuels, coolants, lubricants, etc.

#### Premium unleaded gasoline

##### Warning!



Gasoline is highly flammable and poisonous. It burns violently and can cause serious personal injury.

Never allow sparks, flame or smoking materials near gasoline!

Turn off the engine before refueling.

Whenever you are around gasoline, avoid inhaling fumes and skin or clothing contact, extinguish all smoking materials.

Direct skin contact with fuels and the inhalation of fuel vapors are damaging to your health.

**!** *To maintain the engine's durability and performance, premium unleaded gasoline must be used. If premium unleaded gasoline is not available and low octane fuel is used, follow these precautions:*

- *Have the fuel tank only partially filled with unleaded regular gasoline and fill up with premium unleaded gasoline as soon as possible.*
- *Avoid full throttle driving and abrupt acceleration.*
- *Do not exceed an engine speed of 3000 rpm if the vehicle is loaded with a light load such as two persons and no luggage.*
- *Do not exceed  $\frac{2}{3}$  of maximum accelerator pedal position if the vehicle is fully loaded or operating in mountainous terrain.*

#### Fuel requirements

Only use premium unleaded fuel:

- The octane number (posted at the pump) must be 91 min. It is an average of both the Research Octane Number (RON) and the Motor Octane Number (MON):  $(RON+MON)/2$ . This is also known as the ANTI-KNOCK INDEX.

Unleaded gasoline containing oxygenates such as ethanol, IPA, IBA and TBA can be used provided the ratio of any one of these oxygenates to gasoline does not exceed 10%; MTBE must not exceed 15%.

The ratio of methanol to gasoline must not exceed 3% plus additional cosolvents.

Using mixtures of ethanol and methanol is not allowed. Gasohol, which contains 10% ethanol and 90% unleaded gasoline, can be used.

These blends must also meet all other fuel requirements, such as resistance to spark knock, boiling range, vapor pressure, etc.

### Gasoline additives

A major concern among engine manufacturers is carbon build-up caused by gasoline. Mercedes-Benz recommends only the use of quality gasoline containing additives that prevent the build-up of carbon deposits.

After an extended period of using fuels without such additives, carbon deposits can build up, especially on the intake valves and in the combustion area, leading to engine performance problems such as:

- Warm-up hesitation
- Unstable idle
- Knocking/pinging
- Misfire
- Power loss

In areas where carbon deposits may be encountered due to lack of availability of gasolines which contain these additives, Mercedes-Benz recommends the use of additives approved by us for use on Mercedes-Benz vehicles. Refer to the Factory Approved Service Products pamphlet (USA only) or contact an authorized Mercedes-Benz Light Truck Center for a listing of approved product(s). Follow directions on product label.

Do not blend other fuel additives with fuel. This only results in unnecessary cost and may be harmful to the engine operation.

**!** *Damage or malfunction resulting from poor fuel quality or from blending additional fuel additives other than those tested and approved by us for use on Mercedes-Benz vehicles are not covered by the Mercedes-Benz Limited Warranty.*

### Coolants

The engine coolant is a mixture of water and anticorrosion/antifreeze, which provides:

- Corrosion protection
- Freeze protection
- Boiling protection (by increasing the boiling point)

The cooling system was filled at the factory with a coolant providing freeze protection to approximately -35°F (-37°C) and corrosion protection.

**!** *Add premixed coolant solution only. Adding water and MB 325.0 Anticorrosion/Antifreeze separately from each other, could cause engine damage not covered by the Mercedes-Benz Limited Warranty.*

If the antifreeze mixture is effective to -35°F (-37°C), the boiling point of the coolant in the pressurized cooling system is reached at approximately 266°F (130°C).

### Fuels, coolants, lubricants, etc.

The coolant solution must be used year round to provide the necessary corrosion protection and increase boil-over protection. Refer to Maintenance Booklet for replacement interval.

Coolant system design and coolant used determine the replacement interval. The replacement interval published in the Maintenance Booklet is only applicable if MB 325.0 Anticorrosion/Antifreeze solution or other Mercedes-Benz approved products of equal specification are used to renew the coolant concentration or bring it back up to the proper level.

For information on other Mercedes-Benz approved products of equal specification, refer to the Factory Approved Service Products pamphlet (USA only) or contact an authorized Mercedes-Benz Light Truck Center.

To provide important corrosion protection, the solution must be at least 50% anticorrosion/antifreeze (equivalent to freeze protection to approximately  $-35^{\circ}\text{F}$  [ $-37^{\circ}\text{C}$ ]). If you use a solution that is more than 55% anticorrosion/antifreeze (freeze protection to approximately  $-49^{\circ}\text{F}$  [ $-45^{\circ}\text{C}$ ]), the engine temperature will increase due to the lower heat transfer capability of the solution. Therefore, do not use more than this amount of anticorrosion/antifreeze.

If the coolant level is low, water and MB 325.0 Anticorrosion/Antifreeze should be used to bring it up to the proper level (have cooling system checked for signs of leakage). Please make sure the mixture is in accordance with label instructions.

The water in the cooling system must meet minimum requirements, which are usually satisfied by normal drinking water. If you are not sure about the water quality, contact an authorized Mercedes-Benz Light Truck Center.

### Anticorrosion/antifreeze

Your vehicle contains a number of aluminum parts. The use of aluminum components in motor vehicle engines necessitates that anticorrosion/antifreeze coolant used in such engines be specifically formulated to protect the aluminum parts. Failure to use such anticorrosion/antifreeze coolant will result in a significantly shortened service life.

Therefore, the following product is strongly recommended for use in your vehicle:  
Mercedes-Benz  
325.0 Anticorrosion/Antifreeze agent.

Before the start of the winter season (or once a year in hot southern regions), you should have the anticorrosion/antifreeze concentration checked. The coolant is also regularly checked each time you bring your vehicle to an authorized Mercedes-Benz Light Truck Center for service.

*Anticorrosion/antifreeze quantity*

| Model           | Approximate freeze protection |                   |
|-----------------|-------------------------------|-------------------|
|                 | -35°F (-37°C)                 | -49°F (-45°C)     |
| <b>G 500</b>    | 6.35 US qt (6.0 l)            | 7.0 US qt (6.6 l) |
| <b>G 55 AMG</b> | 6.76 US qt (6.4 l)            | 7.4 US qt (7.0 l) |

### Fuels, coolants, lubricants, etc.

#### Windshield/rear window washer system and headlamp cleaning system

Fluid for the windshield/rear window washer system and the headlamp cleaning system is supplied from the windshield washer reservoir. It has a capacity of 7.9 US qt (7.5 l).

The windshield washer reservoir is located on the passenger side of the engine compartment (▷ page 275).

- ▶ Refill the washer reservoir with MB Windshield Washer Concentrate “MB SummerFit” and water (or concentrate and commercially available premixed windshield washer solvent/antifreeze, depending on ambient temperatures).

#### Warning!



Washer solvent/antifreeze is highly flammable. Do not spill washer solvent/antifreeze on hot engine parts, because it may ignite and burn. You could be seriously burned.

#### Windshield/rear window and headlamp washer fluid mixing ratio

For temperatures above freezing point, use MB Windshield Washer Concentrate “MB SummerFit” and water:

- 1 part “MB SummerFit” to 100 parts water  
(1.34 fl oz [40 ml] “MB SummerFit” to 1 gal [4.0 l] water)

For temperatures below freezing point, use MB Windshield Washer Concentrate “MB SummerFit” and commercially available premixed windshield washer solvent/antifreeze:

- 1 part “MB SummerFit” to 100 parts solvent  
(1.34 fl oz [40 ml] “MB SummerFit” to 1 gal [4.0 l] solvent)

- A**
- ABS 27, 88
    - Indicator lamp 324–325, 327
    - LOW RANGE mode 90
    - Messages in display 340
  - Accelerator position (Automatic transmission) 166
  - Accessory weight 304
  - Accident
    - In case of 61
  - Activating
    - Air conditioning (cooling) 190
    - Air recirculation mode 188
    - Anti-theft alarm system 97
    - Central locking (control system) 155
    - Defrost 187
    - Easy-entry/exit feature 156
    - ESP® 95
    - Exterior headlamps 56
    - Exterior lamps 118
    - Exterior rear view mirror parking position 178
    - Headlamps 56
    - Immobilizer 96
    - Rear window defroster 181
    - Windshield defroster 181
    - Windshield wipers 58
  - Adding
    - Coolant 275
    - Engine oil 273
  - Additional turn signals 378
  - Adjusting 41
    - Air distribution 186
    - Air volume 186
    - Exterior rear view mirrors 46
    - Head restraint fore and aft adjustment 43
    - Head restraint height 43
    - Head restraint height, rear seats 110
    - Instrument cluster illumination 130
    - Interior rear view mirror 46
    - Mirrors 46
    - Multicontour seat\* 109
  - Seat backrest tilt 43
  - Seat cushion depth 109
  - Seat cushion tilt 43
  - Seat fore and aft adjustment 43
  - Seat height 43
  - Seats 41
  - Steering column in/out 45
  - Steering column up/down 45
  - Steering wheel 44
- Advanced TPMS
- Messages in display 342–343, 361–362
- Air bags 70
- BabySmart™ air bag deactivation system 81
  - Front 73
  - Safety guidelines 72
  - Window curtain air bags 74
- Air conditioning 189
- Air conditioning refrigerant 425
- Air distribution
- Adjusting 186



- Air pressure 304
  - Air pressure see Tire inflation pressure
  - Air recirculation mode 188
    - Activating 188
    - Deactivating 189
  - Air vents, Rear
    - Climate control 191
  - Air volume
    - Adjusting 186
  - Alarm
    - Audible 87, 96
    - Canceling 97, 98
    - Visual 96
  - Alarm system
    - Anti-theft 96
  - Anticorrosion/antifreeze 428
  - Anti-theft alarm system
    - Arming 97
    - Canceling alarm 97
    - Disarming 97
  - Anti-theft systems 96
    - Anti-theft alarm system 96
    - Tow-away alarm 98
  - Aquaplaning see Hydroplaning
  - Armrest
    - Storage box in front of 217
    - Storage compartments below 216
    - Telephone\* tray below 216
  - Ashtrays 220
    - In center console 220
    - In rear passenger compartment 221
  - Aspect ratio 304
  - At the gas station 264
  - ATF (automatic transmission fluid) 273
  - Audio menu 141
    - Selecting radio station 141
  - Audio search function 155
  - Auto-dimming for rear view mirror 177
  - Automatic central locking
    - Activating/deactivating (control system) 155
  - Automatic headlamp mode 118
  - Automatic locking when driving 106
  - Automatic operation
    - Interior lighting control 125
  - Automatic transmission 162
    - Accelerator position 166
    - Emergency operation (Limp Home Mode) 169
    - Fluid level 273
    - Gear ranges 167
    - Gear selector lever 162
    - Gear selector lever position 163, 164
    - Gear shifting malfunctions 169
    - Kickdown 166
    - One-touch gearshifting 168
    - Shifting procedure 163
    - Transmission fluid 273
- B**
- BabySmart™
    - Air bag deactivation system 81
    - Compatible child seats 81
    - Self-test 82
  - Backup lamp
    - Message in display 357
  - Backup lamps
    - Bulbs 378
    - Replacing bulbs 386
  - Bar 304
  - BAS 88, 90

- Batteries
    - SmartKey (replacing) 376
  - Batteries, SmartKey
    - Check lamp 103
    - Checking 103
  - Battery box
    - Fuse box in 408
  - Battery discharged
    - Jump starting 399
  - Battery, vehicle 396
    - Charging 398
    - Disconnecting 398
    - Messages in display 344–345
    - Reconnecting 398
    - Reinstalling 398
    - Removing 398
  - Bead 304
  - Block heater (Canada only) 310
  - Blocking rear door window operation 86
  - B-pillar 412
  - Brake fluid 266, 425
    - Message in display 346
  - Brake lamp bulbs, left and right 378
  - Brake lamp, high mounted 378
  - Brake lamps
    - Messages in display 354
  - Brake pads
    - Message in display 347
  - Brakes 246
    - Warning lamp 326–327
  - Break-in period 244
  - Brush guard 375
    - Lowering 375
    - Raising and securing 375
  - Bulbs, replacing
    - Additional turn signals 378
    - Backup lamps 378, 386
    - Brake lamps 378, 386
    - Front fog lamps 378, 382
    - Front lamps 378
    - Front turn signal lamps 378, 383
    - High beam lamps 378
    - High mounted brake lamp 378
    - License plate lamps 378, 387
    - Locator lighting lamps 378
    - Low beam lamps 378
    - Parking lamps 378, 380
    - Rear fog lamp 378, 386
  - Rear lamps 378
  - Rear turn signal lamps 378
  - Side marker lamps 378, 384
  - Standing lamps 378, 380
  - Tail lamp assemblies 378
  - Tail lamp unit 385
- C**
- Call priority, Tele Aid 235
  - Calling up
    - Maintenance service indicator display 313
    - Range (distance to empty) 158
  - Capacities
    - Fuels, coolants, lubricants, etc. 422
  - Cargo area see Cargo compartment
  - Cargo compartment
    - Expanding 206
    - Tailgate 105
    - Tie-down rings 209
  - Cargo compartment cover blind 214
    - Installing 214
    - Removing 214
    - Rolling out 214
    - Rolling up 214
  - Cargo compartment lamps 127

- Cargo tie-down rings 209
- Carpets, Cleaning 321
- Catalytic converter 262
- CD changer 368
- CD player
  - Operating 143
- Center console 30
  - Front passenger front air bag off indicator lamp 337
  - Lower part 31
  - Upper part 30
- Central locking
  - From inside 107
  - Switch 107
  - Switching on/off (control system) 155
  - Unlocking from inside 107
- Central unlocking
  - Switch 107
- Certification label 412
- Charging
  - Vehicle battery 398
- Checking
  - Coolant level 266, 274
  - Oil level 266, 269
  - Checking tire pressure electronically with the Advanced Tire Pressure Monitoring System (Advanced TPMS) 289
- Checklist
  - Off-road driving 254
- Child safety 78
  - Infant and child restraint systems 68, 79
  - LATCH child seat anchors 83
- Child safety switch see Blocking of rear door window operation
- Cigarette lighter 222
- Cleaning
  - Gear selector lever 321
  - Headlamps 177
  - Headliner 321
  - Leather upholstery 322
  - Light alloy wheels 320
  - Rear Parking Assist sensors 318, 319
  - Seat belts 321
  - Steering wheel 321
- Upholstery 322
- Windows 319
- Windshield 59
- Wiper blades 319
- Wood trims 322
- Cleaning tires 279
- Climate control 182
  - Adjusting air distribution 186
  - Adjusting air volume 186
  - Air conditioning 189
  - Air recirculation mode 188
  - Defogging windshield 188
  - Defrosting 187
  - Rear window defroster 181
  - Residual heat utilization (REST) 190
  - Setting the temperature 185
  - Windshield defroster 180
- Clock 27
- Closing
  - Glove box 215
  - Hood 269
  - Tailgate 106
  - Tilt/sliding sunroof 196, 374
  - Windows 192
- Closing tilt/sliding sunroof
  - In an emergency 374

- Cockpit 24
- Cold tire inflation pressure 304
- COMAND see separate operating instructions
- Combination switch 25, 122
  - High beam flasher 57, 122
  - High beam headlamps 122
  - Turn signals 57
  - Windshield wipers 58
- Control and operation of radio transmitters 261
- Control system 133
  - Audio menu 141
  - Convenience submenu 156
  - Display digital speedometer 140
  - Display outside temperature 140
  - Functions 135, 137, 139
  - Instrument cluster submenu 149
  - Lighting submenu 151
  - Menus 136, 137, 139
  - Multifunction display 133
  - Multifunction steering wheel 134
  - NAVI menu 144
  - Satellite radio (USA only) 142
  - Selecting radio system 141
  - Settings menu 146
- Standard display menu 140
- Submenus 135, 137, 139
- TEL menu 159
- Trip computer menu 157
- Vehicle status message memory menu 144
- Vehicle submenu 154
- Convenience feature 194
- Convenience submenu 156
  - Activating easy-entry/exit feature 156
- Coolant 274, 427
  - Adding 275
  - Anticorrosion/antifreeze quantity 428
  - Capacities 422
  - Checking level 274
  - Messages in display 347–350
  - Temperature 263
  - Temperature gauge 131
- Coolant level
  - Checking 266, 274
- Coolant temperature gauge 27
- Corner-illuminating front fog lamps 122
- Crossing obstacles 258
- Cruise control 197
  - Canceling 198
  - Driving downhill 198
  - Driving uphill 198
  - Fine adjustment 199
  - Message in display 350
  - Setting current speed 198
  - Setting speed 199
- Cruise control lever 198
- Cup holders 219
  - In front passenger footwell 220
  - In rear passenger footwell 220
  - Next to armrest 219
- Curb weight 304

- D**
- Data recording (vehicle) 20
  - Daytime running lamp mode 119
    - Setting 151
  - Deactivating
    - Air conditioning (cooling) 189
    - Air recirculation mode 189
    - Alarm 97
    - Anti-theft alarm system 97
    - Central locking (control system) 155
    - Cruise control 198
    - Defrost 188
    - ESP® 94
    - Exterior lamps 118
    - Exterior lamps delayed shut-off 153
    - Headlamps 64
    - Immobilizer 96
    - Interior lighting delayed shut-off 154
    - Rear window defroster 181
    - Tow-away alarm 98
    - Windshield defroster 181
  - Deep water see Standing water
  - Defrosting 187
  - Delayed shut-off
    - Exterior lamps 153
    - Interior lighting 154
  - Department of Transportation see DOT
  - Dialing
    - A number (telephone) 160
  - Differential locks 173
    - Switching off 176
    - Switching on 175
  - Difficulties
    - While driving see Problems while driving
    - With starting 54
  - Direction of rotation (tires) 280
  - Discharged battery
    - Jump starting 399
  - Disconnecting
    - Vehicle battery 398
  - Displays
    - Maintenance service indicator message 311
    - Messages 271, 338
    - Selecting display for status indicator 150
    - Showing vehicle status messages 145
  - Door
    - Entry lamps 129
    - Remote door unlock (Tele Aid) 235

- Door control panel 33
- Door handle 33
- Doors
  - Message in display 350
  - Opening from the inside 104
- DOT 305
- Downhill driving
  - Cruise control 198
- Drink holders see Cup holders
- Drinking and driving 245
- Driving
  - General instructions 48, 245
  - In winter 251
  - Problems 61
  - Safety systems 88
  - Through standing water 252
- Driving abroad 261
- Driving and safety systems
  - 4-ETS 91
  - ABS 88
  - BAS 90
  - EBB 92
  - ESP® 92
- Driving instructions 245
  - Passenger compartment 252
- Driving off 247

- Driving on sand 259
- Driving systems 197
  - Cruise control 197
  - Driving safety systems 88
  - Rear Parking Assist 200
  - Rear view camera 203
  - Rear view camera\* 203
- Driving through water 257
- E**
- Easy-entry/exit feature
  - Activating 156
- EBB 88, 92
- Electrical fuses 405
- Electrical outlet 223
  - In cargo compartment 224
  - In front passenger footwell 223
  - In rear passenger footwell 224
- Electrical system
  - Technical data 419
- Electronic Brake Booster (EBB) 92
- Electronic Stability Program see ESP®
- Electronic systems
  - Message in display 365
- Electronic Traction System (ETS) 91
- Emergency calls
  - Tele Aid 230
- Emergency, In case of
  - Roadside Assistance 232
- Emergency operation
  - Remote door unlock, Tele Aid 235
- Emergency operation (Limp Home Mode) 169
- Emergency operations
  - Closing tilt/sliding sunroof 374
  - Locking the vehicle 371
  - Opening tilt/sliding sunroof 374
  - Unlocking the tailgate 371
  - Unlocking the vehicle 370
- Emergency Tensioning Device see ETD
- Emission control 263
- Emission control information label 413
- Ending
  - A call (telephone) 160
- Engine
  - Compartment 267
  - Starting with SmartKey 54
  - Technical data 415
  - Turning off with SmartKey 64
- Engine cleaning 316
- Engine compartment 267
  - Hood 267
- Engine malfunction indicator lamp 27, 328–329
- Engine oil 269, 425
  - Adding 273
  - Additives 425
  - Checking level 269
  - Consumption 269
  - Messages in display 271, 351–352
  - Oil dipstick 272
- Engine oil level see Oil level
- ESP® 27, 88, 92
  - Messages in display 341
  - Switching off 94
  - Switching on 95
  - Warning lamp 330–331
- ETD 68, 78
  - Safety guidelines 72
- Expanding cargo compartment 206
- Extending gear range 168
- Exterior lamp switch 117
- Exterior lamps
  - Delayed shut-off 153
- Exterior rear view mirrors
  - Adjusting 46
- Exterior view 22

## F

- Fastening the seat belts 48
- Fine adjustment
  - Cruise control 199
- First aid kit 366
- Flat tire 390
  - Lifting the vehicle 391
  - Lowering the vehicle 394
  - Mounting the spare wheel 391
  - Spare wheel 368
- Floormats 224
- Fog lamp, rear 121, 378
- Fog lamps
  - Corner-illuminating front fog lamps 122
- Fog lamps, front 121
- 4-ETS 88, 91
- Front air bags 73
- Front axle differential lock
  - Switching on 176
- Front fog lamps
  - Messages in display 355
  - Replacing bulbs 378, 382
- Front lamps
  - Replacing bulbs 378, 380
  - Switching on 117
- Front passenger front air bag off indicator lamp 81, 337
- Front seat head restraints
  - Installing 109
  - Removing 108
- Front towing eye 404
- Front turn signal lamp
  - Replacing bulbs 383
- Fuel 265
  - Additives 427
  - Gasoline additives 427
  - Message in display 365
  - Premium unleaded gasoline 265, 424, 426
  - Refueling 264
  - Requirements 426
  - Reserve warning 27
  - Technical data 422
- Fuel additives 427
- Fuel consumption statistics
  - Since last reset 158
  - Since start 157
- Fuel filler cap
  - Message in display 353
- Fuel filler flap 264
  - Locking 264
  - Opening 372
  - Unlocking 264
- Fuel requirements 426
- Fuel reserve tank
  - Message in display 353
- Fuel reserve warning lamp 331
- Fuel tank
  - Capacity 424
  - Filler flap 264
- Fuels, coolants, lubricants, etc.
  - Capacities 422
- Functions (control system) 135, 137, 139
- Fuse box 406, 407, 408
- Fuses 405
  - Fuse box in battery box 408
  - Fuse box in front passenger footwell 406
  - Fuse box in middle tunnel 407
  - Main fuse box in passenger compartment 406

**G**

Garage door opener 32, 236

Gasoline see Fuel

Gasoline additives 427

GAWR 305

Gear range

Automatic transmission 167

Shifting into optimal 169

Transfer case 170

Gear range limit

Canceling 169

Gear selector lever 27, 162, 373

Cleaning 321

Lock 54

Position 164

Position (automatic

transmission) 27, 163

Unlocking manually 373

Global

Locking 102

Unlocking 102

Glove box 25, 215

Closing 215

Locking and unlocking  
separately 216

Opening 215

Good visibility 177

Gross Axle Weight Rating see GAWR

Gross Trailer Weight see GTW

Gross Vehicle Weight Rating see GVWR

Gross Vehicle Weight see GVW

GTW 305

GVW 305

GVWR 305

**H**

Hard plastic trim items, cleaning 321

Hazard warning flasher 124

Switching off 124

Switching on 124

Head restraints 108

Power seats 43

Headlamp cleaning system 275

Headlamps

Automatic control 118

Cleaning 318

Cleaning system 177, 275

Switching off 64

Switching on 56

Washer fluid 430

Washer system 430

Headlight switch-off delay see Delayed  
switch-off, exterior lamps

Headliner

Cleaning 321

Heated seats 112

Heated steering wheel 225

Height adjustment

Head restraints 43

Seat belt outlet 52

Steering wheel 44

High beam flasher 57, 122

High beam headlamps

Messages in display 355

Replacing bulbs 378

Switching on 122

High mounted brake lamp 378

Message in display 354

Hood 267

Closing 269

Message in display 353

Opening 267

Hydroplaning 249

**I**

Identification labels 412

Certification label 412

Ignition

Switching on 54

Ignition (Position in starter switch) 39



- Immobilizer 96
    - Activating 96
    - Deactivating 96
  - Infant and child restraint systems 79
    - Installing 84
    - LATCH child seat anchors 83
  - Information button see Tele Aid
  - Inside rear view mirror
    - Auto-dimming 177
  - Installing
    - Cargo compartment cover blind 214
    - Infant and child restraint systems 84
    - Wiper blades 389
  - Instructions
    - Loading 208
  - Instrument cluster 26, 130
    - Coolant temperature gauge 131
    - Digital speedometer 140
    - Illumination 130
    - Lamps in 324–334
    - Multifunction display 133
    - Outside temperature 140
    - Outside temperature indicator 132
    - Selecting language 149
  - Instrument lighting 130
  - Instruments and controls see Cockpit
  - Interior lighting
    - Automatic operation 125
    - Delayed shut-off 154
    - Manual operation 126
  - Interior lighting, front 125
  - Interior lighting, rear 126
  - Interior rear view mirror
    - Adjusting 46
  - Intermittent wipe 60
    - Activating 60
    - Deactivating 60
  - Intermittent wiping 59
- J**
- Jack 367
  - Jump starting 399
- K**
- Key
    - Messages in display 353
  - Key, mechanical 370
  - Key, SmartKey
    - Battery check lamp 102
    - Checking the batteries 103
    - Factory setting 102
    - Global locking 102
    - Global unlocking 102
    - Loss of 103
    - Positions in starter switch 39
    - Remote control 100
    - Restoring to factory setting 103
    - Selective setting 102
    - Starting the engine 54
    - Unlocking with 38
  - Keys 100
  - Kickdown (Automatic transmission) 166
  - Kilometers/miles in speedometer 149
  - Kilopascal 305
  - Km/h or mph in speedometer 149
- L**
- Labels, identification 412
  - Lamp bulbs, exterior 377
  - Lamp in center console 337

- Lamps in instrument cluster 324
- Lamps, exterior
  - Front 378
  - Messages in display 354–359
  - Rear 378
  - Replacing bulbs for front 380
  - Replacing bulbs for rear 385
- Lamps, indicator and warning
  - ABS 324–325, 327
  - Battery (SmartKey) 102
  - Brakes 326–327
  - check engine 328–329
  - Engine diagnostics 328–329
  - ESP® 330–331
  - Fuel reserve 331
  - Instrument cluster 324–334
  - SRS 69, 334
  - Turn signals 27
- Language
  - Setting 149
- LATCH child seat anchors 83
- Layout of poly-V-belt drive 414
- Leather upholstery
  - Cleaning 322
- License plate lamps
  - Messages in display 356
  - Replacing bulbs 378, 387
- Lifting
  - Vehicle 391
- Light alloy wheels
  - Cleaning 320
  - Technical data 417, 418
- Light sensor
  - Message in display 354
- Lighter see Cigarette lighter
- Lighting 117
  - Automatic headlamp mode 118
  - Combination switch 122
  - Daytime running lamp mode 119
  - Exterior lamp switch 117
  - Front fog lamps 121
  - High beam flasher 122
  - High beams 122
  - Instrument cluster illumination 130
  - Interior, front 125
  - Interior, rear 126
  - Locator lighting 120
  - Low beams 117
  - Manual headlamp mode 118
  - Night security illumination 120
- Parking lamps 117
- Rear fog lamp 121
- Settings (control system) 151
- Limiting gear range 168
- Limp Home Mode 169
- Loading 206
  - Cargo compartment cover blind 214
  - Cargo tie-down rings 209
  - Instructions 208
  - Partition net\* 210
  - Roof rack 206
- Loading terminology 304
- Loading the vehicle 280
- Locator lighting 120
  - Setting 152
- Locator lighting lamps
  - Replacing bulbs 378
- Locking 62, 100
  - Fuel filler flap 264
  - Global, SmartKey 102
  - Vehicle in an emergency 371
- Loss of keys 103

- Loss of Service and Warranty Information
  - Booklet 411
- Low beam headlamps
  - Messages in display 356
  - Replacing bulbs 378
- LOW RANGE - ABS 90
- Lowering
  - Vehicle 394
- Lubricants
  - Technical data 422
- M**
- Main dimensions 420
- Maintenance 311
- Maintenance service
  - Basic service (Service A) 311
  - Calling up the maintenance service indicator display 313
  - Extended service (Service B) 311
  - Overdue 313
  - Types 313
  - When due 311
- Maintenance service indicator
  - Calling up 313
  - Clearing 313
- Maintenance service indicator display
  - Calling up 313
- Maintenance service indicator message 311
  - Clearing 312
- Malfunction
  - Displaying 145
  - Rear Parking Assist 203
- Manual headlamp mode 118
- Manual operation
  - Interior lighting control 126
- Manual operations
  - Fuel filler flap 372
  - Locking the vehicle 371
  - Tilt/sliding sunroof 374
  - Unlocking gear selector lever 373
  - Unlocking the driver's door 370
  - Unlocking the tailgate 371
- Maximum load rating 305
- Maximum loaded vehicle weight 305
- Maximum tire inflation pressure 305
- Mechanical key 370
  - Removing 370
- Memory function 114
  - Recalling positions from memory 115
  - Storing exterior rear view mirror parking position 116
  - Storing key dependent settings 115
- Menus 135
  - Audio 141
  - In control system 136, 137, 139
  - NAVI 144
  - Standard display 140
  - Submenus 135
  - TEL 159
  - Trip computer 157
  - Vehicle status message memory 144
- Messages in the multifunction display 338
  - Symbol messages 344-365
  - Text messages 340-343
- Middle tunnel
  - Fuse box in 407
- Miles/kilometers in speedometer
  - Setting 149

## Mirrors

- Activating exterior rear view mirror
    - parking position 178
  - Adjusting 46
  - Auto-dimming for rear view mirror 177
  - Exterior rear view mirrors 46
  - Interior rear view mirror 46
  - Storing exterior rear view mirror
    - parking position 116
- Mobile phone see Telephone\*
- MON 265
- Monitoring reach
  - Rear Parking Assist 201
- Mph or km/h in speedometer setting 149
- Multicontour seat\* 109
- Multifunction display 133
  - Selecting language 149
- Multifunction display messages
  - ABS 340
  - Advanced TPMS 342–343, 361–362
  - Backup lamp 357
  - Battery 344–345
  - Brake fluid 346
  - Brake lamps 354

- Brake pads 347
- Coolant 347–350
- Cruise control 350
- Doors 350
- Electronic systems 365
- Engine oil 351–352
- ESP® 341
- Front fog lamps 355
- Fuel 365
- Fuel filler cap 353
- Fuel reserve tank 353
- High beam headlamps 355
- High mounted brake lamp 354
- Hood 353
- Key 353
- Lamps, exterior 354–359
- License plate lamps 356
- Light sensor 354
- Low beam headlamps 356
- Parking brake 347
- Parking lamps 356
- Rear fog lamp 357
- Side marker lamps 355
- SRS 360
- Tail lamps 357
- Tailgate 364

- Tele Aid 364
  - Telephone\* 364
  - Tires 342–343, 361–362
  - Transfer case 363
  - Turn signal lamps 358–359
  - Washer fluid 365
- Multifunction steering wheel 28, 134
  - Buttons 134

**N**

- Navigation system
  - Operating 144
  - See separate COMAND operating instructions
- Night security illumination 120
  - Setting 153
- Normal occupant weight 305

**O**

- Occupant distribution 305
- Occupant safety 68
  - Air bags 70
  - Children in the vehicle 78
  - Fastening the seat belt 48
  - Front passenger front air bag off indicator lamp 81
  - Infant and child restraint systems 79
  - LATCH child seat anchors 83
  - Seat belts 48, 72
- Odometer, main 27
- Off-road driving 253
  - Checklist 254
  - Crossing obstacles 258
  - Driving on sand 259
  - Driving through water 257
  - Returning 260
  - Rules 253
  - Special driving features 253
  - Steep terrain 255
- Oil
  - Adding 273
  - Consumption 269
  - Oil dipstick 272

## Oil level

- Checking 266
- Checking with the control system 270
- Checking with the oil dipstick (G 500 only) 272
- One-touch gearshifting 168
- Canceling gear range limit 169
- Extending gear range 168
- Limiting gear range 168
- Opening
  - Doors from the inside 104
  - Fuel filler flap 264
  - Fuel filler flap manually 372
  - Glove box 215
  - Hood 267
  - Tailgate 105
  - Tilt/sliding sunroof 196, 374
  - Tilt/sliding sunroof in an emergency 374
  - Windows 192

## Operating

- CD player 143
- COMAND see separate operating instructions
- Navigation system 144
- Radio 141
- Radio transmitters 261
- Telephone 159
- Operator's Manual 10
- Ornamental moldings 317
- Outside temperature indicator 132
- Overdue maintenance service 313
- Overhead control panel 32
- P**
  - Paintwork 316
  - Paintwork code 412
  - Panic alarm 87
    - Panic button on SmartKey 87
  - Parcel net
    - In front passenger footwell 218
  - Parking 62, 248
  - Parking brake 55, 62
    - Engaging 62
    - Message in display 347
    - Releasing 55

- Parking lamp, front
  - Replacing bulbs 380
- Parking lamps
  - Messages in display 356
  - Replacing bulbs 378
- Parking position
  - Exterior rear view mirror 116
  - Exterior rear view mirrors 178
- Parktronic see Rear Parking Assist
- Partition net\* 210
  - Installing behind front seats 212
  - Installing behind rear seat bench 211
  - Loosening 213
  - Removing and storing 213
- Parts service 410
- Passenger compartment 252
  - Interior lighting 127
  - Interior rear view mirror 46
  - Main fuse box in 406
  - Parcel net in front passenger footwell 218
  - Storage bags 217
- Passenger footwell
  - Fuse box in 406
- Passenger safety see Occupant safety
- Pedals 245
- Phone book
  - Loading 160
  - Quick search 160
- Phone number
  - Dialing 160
  - Redialing 161
- Plastic and rubber parts, cleaning 320
- Poly-V-belt drive
  - Layout 414
- Positions (memory function)
  - Recalling from memory 115
  - Storing into memory 115
- Potential problems associated with underinflated and overinflated tires 294
- Power assistance 246
- Power seat
  - Adjusting head restraint fore and aft adjustment 43
  - Adjusting head restraint height 43
  - Adjusting seat backrest tilt 43
  - Adjusting seat cushion tilt 43
  - Adjusting seat height 43
  - Seat fore and aft adjustment 43
- Power tilt/sliding sunroof 195
  - Convenience feature 194
  - Summer opening feature 193
- Power washer 315
- Power windows 192
  - Blocking of rear door window operation 86
  - Convenience feature 194
  - Side windows 192
  - Summer opening feature 193
- Practical hints
  - First aid kit 366
  - Fuses 405
  - Spare wheel 368
  - Towing the vehicle 401
  - Vehicle jack 367
  - Vehicle tool kit 366
- Premium unleaded gasoline 426
- Problems
  - While driving 61
- Product information 9
- Production options weight 306
- PSI 306
- Q**
- Quick search
  - Phone book 160

- R**
- Radio
    - Satellite (USA only) 142
    - Selecting stations 141
  - Radio transmitters, control and operation 261
  - Range (distance to empty)
    - Calling up 158
  - Range of sensors
    - Rear Parking Assist 201
  - Reading lamp 32
  - Rear axle differential lock
    - Switching on 176
  - Rear door window
    - Blocking operation 86
  - Rear fog lamp
    - Messages in display 357
    - Replacing bulbs 386
  - Rear interior lamps 126
  - Rear lamps
    - Replacing bulbs 378
  - Rear lamps see Tail lamps
  - Rear Parking Assist 200
    - Cleaning sensors 318, 319
    - Malfunction 203
    - Monitoring reach 201
    - Warning indicators 202
  - Rear seat bench
    - Split 206
  - Rear seat head restraints
    - Installing 111
    - Removing 111
  - Rear towing eye 404
  - Rear view camera 203
  - Rear view mirror auto-dimming 177
  - Rear view mirrors see Mirrors
  - Rear window defroster 181
    - Activating 181
    - Deactivating 181
  - Rear window wiper
    - Intermittent wipe 60
  - Rear window wiper/washer 60
  - Recommended tire inflation pressure 306
  - Reconnecting
    - Vehicle battery 398
  - Recovery services, Stolen vehicle (Tele Aid) 236

- Refrigerant
  - Air conditioning 425
- Refueling 264
- Regular checks 265
- Reinstalling
  - Vehicle battery 398
- Remote control
  - SmartKey 100
- Remote door unlock, Tele Aid\* 235
- Removing
  - Cargo compartment cover blind 214
  - Vehicle battery 398
  - Wheel 393
  - Wiper blades 388
- Removing mechanical key 370
- Replacing
  - Brake lamp bulbs 378
  - Bulbs 377
  - Front lamp bulbs 380
  - Rear lamp bulbs 385
  - SmartKey batteries 376
  - Wiper blades 388

- Replacing bulbs
  - Additional turn signals, Exterior rear view mirrors 385
  - High mounted brake lamp 387
  - Locator lighting, Exterior rear view mirrors 385
- Resetting
  - All functions (control system) 146
  - Fuel consumption statistics 158
  - Maintenance service indicator 313
  - Trip odometer 131
- Restraint systems 68
  - Air bags 68
  - Child seats 68
  - Emergency Tensioning Device (ETD) 68
  - Lower anchors and tethers for children (LATCH) 68
  - Seat belts 68
- Restraint systems see Infant and child restraint systems
- Returning from off-road driving 260
- Rim 306
- Rims 416
- Roadside Assistance button see Tele Aid
- Rolling out
  - Cargo compartment cover blind 214
- Rolling up
  - Cargo compartment cover blind 214
- RON 265
- Roof rack 206
- Rubber parts, Cleaning 320
- S**
- Safety
  - Occupant 68
- Safety belts see Seat belts
- Safety systems
  - Driving 88
- Satellite radio (USA only) 142
- Seat backrest
  - Folding forward 207
  - Returning to original position 207
- Seat belt force limiter 78
- Seat belt outlet
  - Height adjustment 52
- Seat belt outlet height adjustment 52
- Seat belt telltale
  - 332–333
- Seat belts 68, 74
  - Cleaning 321
  - Fastening 48
  - Proper use of 53, 76
  - Safety guidelines 72
- Seat bench
  - Folding forward 207
  - Returning to original position 207
- Seat cushion depth
  - Adjusting 109
- Seating capacity 282
- Seats 108
  - Adjusting 41
  - Heating 112
  - Multicontour seat\* 109
- Selecting
  - Display for status indicator 150
- Self-test
  - BabySmart™ air bag deactivation system 82
  - Tele Aid 230
- Service
  - Parts 410
- Service and Warranty Booklet
  - Loss of 411



- Service life (tires) 278
- Service System see Maintenance
- Setting
  - Clock 27
  - Cruise control 198
  - Daytime running lamp mode 151
  - Higher speed in cruise control 198
  - Individual vehicle settings 146
  - Instrument lighting 130
  - Interior lighting delayed shut-off 154
  - Lamps and lighting (control system) 151
  - Language, multifunction display 149
  - Locator lighting 152
  - Lower speed in cruise control 199
  - Miles/kilometers in speedometer 149
  - Night security illumination 153
  - Selective 102
  - Slower speed in cruise control 199
  - Speed in cruise control 199
  - Speedometer display mode 149
  - Temperature (interior) 185
  - Units
    - Speedometer 149
- Setting current speed 198
- Settings
  - Convenience functions 156
  - Factory, SmartKey 102
  - Lighting (control system) 151
  - Memory function 115
  - Menus and submenus 135
  - Resetting all (control system) 146
- Settings menu
  - Functions in 146
  - Individual vehicle settings 146
  - Submenus 147
- Shifting
  - Gear selector lever position 164
- Shifting into optimal
  - Gear range 169
- Shifting procedure 163
- Side marker lamps 378
  - Messages in display 355
  - Replacing bulbs 378, 384
- Side markers
  - Cleaning 318
- Side windows
  - Automatic opening 193
  - Cleaning 319
  - Closing 192
  - Opening 192
  - Opening fully 193
  - Stopping 193
- Sidewall 306
- Simultaneous wiping and washing
  - Windshield wipers 59
- Single wipe 59
- SmartKey 100
  - Locking and unlocking 100
  - Replacing batteries 376
  - Unlocking with 38
- Snow chains 310
- Spare parts see Parts service
- Spare wheel 368
  - Mounting 391
- Speed
  - Setting current 198
- Speed settings
  - Cruise control 198, 199
- Speedometer 27
  - Setting units 149

- Speedometer display mode
  - Selecting 149
- SRS 76
  - Indicator lamp 334
  - Messages in display 360
- Standing lamp, front
  - Replacing bulbs 380
- Standing lamps
  - Replacing bulbs 378
- Standing water
  - Driving instructions 252
- Starter switch 25, 39
  - Positions 39
- Starting difficulties 54
- Starting position 39
- Starting the engine 54
- Steep terrain 255
- Steering column
  - Adjusting in /out 45
  - Adjusting up/down 45
- Steering wheel
  - Adjusting 44
  - Adjusting in/out 45
  - Adjusting up/down 45
  - Buttons 28
  - Cleaning 321
  - Heated 225
- Stolen Vehicle Recovery services 236
- Stopping
  - Side windows 193
  - Tilt/sliding sunroof 196
- Storage bags
  - In rear passenger compartment 217
- Storage box
  - In front of armrest 217
- Storage compartments 34, 215
  - Armrest 216
  - Below armrest 216
  - Cup holders 219, 220
  - Glove box 215
  - Parcel net in front passenger footwell 218
  - Storage bags 217
- Storing (memory function)
  - Positions into memory 115
- Storing tires 279
- Submenus
  - Convenience 156
  - For settings 135
  - In control system 137, 139
  - Instrument cluster 149
  - Lighting 151
  - Selecting 147
  - Settings menu 147
  - Vehicle 154
- Summer opening feature 193
- Sun visors 179
- Switching
  - Transfer case 170
- Switching off
  - Automatic central locking (control system) 155
  - Delayed (exterior lamps) 153
  - Differential locks 176
  - Engine 64
  - ESP® 94
  - Headlamps 64
  - Heated steering wheel 225

- Switching on
  - Automatic central locking (control system) 155
  - Differential locks 175
  - ESP® 95
  - Front axle differential lock 176
  - Headlamps 56
  - Heated steering wheel 225
  - Rear axle differential lock 176
  - Transfer case differential lock 175
  - Windshield wipers 58
- Symbol messages
  - Multifunction display 344–365
- T**
- Tachometer 27, 132
  - Overspeed range 132
- Tail lamps 385
  - Cleaning 318
  - Messages in display 357
  - Replacing bulbs 378
- Tailgate
  - Closing 106
  - Message in display 364
  - Opening 105
  - Unlocking in an emergency 371
- Tar stains 315
- Technical data
  - Air conditioning refrigerant 425
  - Brake fluid 425
  - Coolant 422
  - Coolants 427
  - Electrical system 419
  - Engine 415
  - Engine oil 425
  - Engine oil additives 425
  - Fuel requirements 426
  - Fuels 422
  - Gasoline additives 427
  - Lubricants 422
  - Main dimensions 420
  - Premium unleaded gasoline 426
  - Rims and tires 416
  - Weights and ratings 421
  - Windshield and headlamp washer system 424, 430
- Tele Aid 229
  - Initiating an emergency call manually 231
  - Message in display 364
- Tele Aid\*
  - Call priority 235
  - Emergency calls 230
  - Information 233
  - Remote door unlock 235
  - Roadside Assistance 232
  - SOS button 231
  - Stolen Vehicle Recovery services 236
  - System self-check 230
- Telephone
  - Answering a call 160
  - Dialing a number from the phone book 160
  - Ending a call 160
  - Loading phone book 160
  - Operating 159
  - Redialing 161
- Telephone cradle
  - Changing 228

- Telephone\* 226
    - Changing mobile phone cradle 228
    - Inserting in cradle 227
    - Installing a different mobile phone cradle 228
    - Message in display 364
    - Removing from cradle 228
  - Telephone\* tray
    - Armrest 216
    - Below armrest 216
  - Temperature
    - Setting interior temperature 185
    - Tires 287
  - Text messages
    - Multifunction display 340–343
  - Tie-down rings (cargo compartment) 209
  - Tightening torque (wheel bolts) 395
  - Tilt/sliding sunroof 195
    - Automatic opening 196
    - Closing 196, 374
    - Opening 196, 374
    - Opening fully 196
    - Stopping 196
  - TIN 306
  - Tire
    - Vehicle maximum load on 307
  - Tire and Loading Information 281
  - Tire and loading terminology 304
  - Tire care and maintenance 278
  - Tire Identification Number see TIN
  - Tire inflation pressure
    - Checking 286, 288
  - Tire inspection 278
  - Tire load rating 306
  - Tire ply composition and material used 306
  - Tire speed rating 250, 297, 306
  - Tire terminology 304
  - Tire traction 249
  - Tires 277, 416
    - Advanced Tire Pressure Monitoring System (Advanced TPMS) 289
    - Advanced TPMS malfunction telltale 335
    - Combination low tire pressure/TPMS malfunction telltale, USA only 27
    - Direction of rotation 280
    - Driving instructions 248
    - Low tire pressure telltale 335
    - Messages in display 342–343, 361–362
    - Retreads 277
  - Rims and tires 416
  - Rotating 307
  - Service life 278
  - Temperature 287, 303
  - Tread depth 279, 309
  - Wear pattern 308
  - Winter 309
- Tongue Weight Rating see TWR
- Tools 366
- Total load limit 306
- Tow-away alarm 30, 98
  - Arming 98
  - Disarming 98
  - Disarming for transport 98
- Tow-away alarm system
  - Canceling alarm 98
- Towing eye, front 404
- Towing eye, rear 404
- Towing the vehicle 401
  - Stranded vehicle 404
- Towing the vehicle - various problem scenarios 403
- Traction 307

- Transfer case 170
  - Gear range 170
  - Messages in display 363
  - Messages in the multifunction display 172
  - Switching 170
- Transfer case differential lock
  - Switching on 175
- Transmission see Automatic transmission
- Tread 307
- Tread depth 279
- Tread depth (tires) 309
- Treadwear indicators 307
- Trip computer 157
- Trip odometer
  - Resetting 131
- Trunk see Cargo compartment
- Turn signal lamps
  - Messages in display 358–359
  - Replacing bulbs 378
- Turn signals 25, 57
  - Additional in mirrors 378
  - Cleaning lenses 318
  - Front bulbs 378
  - Indicator lamps 27
  - Rear bulbs 378
- Turning off
  - Engine 64
- TWR 307
- U**
- Uniform Tire Quality Grading Standards 307
- Units
  - Setting speedometer units 149
- Unlocking 38, 100
  - Driver's door in an emergency 370
  - Fuel filler flap 264
  - Gear selector lever manually 373
  - Global 102
  - In an emergency 370
  - Selective setting 102
  - Tailgate in an emergency 371
  - With the SmartKey 38
- Uphill driving
  - Cruise control 198
- Upholstery
  - Cleaning 322
- Useful features 215
  - Ashtrays 220
  - Cigarette lighter 222
  - Electrical outlets 223
  - Floor mats 224
  - Storage compartments 215
- V**
- Vehicle
  - Data recording 20
  - Individual settings 146, 148
  - Lifting 391
  - Locking 30
  - Locking in an emergency 371
  - Lowering 394
  - Service battery 396
  - Towing 401
  - Unlocking 30
  - Unlocking in an emergency 370
- Vehicle battery 396
- Vehicle care 314
  - Engine cleaning 316
  - Gear selector lever 321
  - Headlamps 318
  - Leather upholstery 322
  - Light alloy wheels 320
  - Ornamental moldings 317

- Paintwork 316
- Power washer 315
- Seat belts 321
- Side markers 318
- Steering wheel 321
- Tail lamps 318
- Tar stains 315
- Turn signals 318
- Upholstery 322
- Vehicle washing 316
- Window cleaning 319
- Wiper blades 319
- Wood trims 322
- Vehicle data recording 20
- Vehicle Identification Number (VIN) 412
- Vehicle jack 367
- Vehicle loading terminology 304
- Vehicle maximum load on the tire 307
- Vehicle Recovery services, Stolen (Tele Aid) 236
- Vehicle status message memory 144
  - Calling up 144
  - Clearing 145
- Vehicle tool kit 366
- Vehicle washing 316
- VIN (Vehicle Identification Number) 412

## W

- Warning indicators
  - Rear Parking Assist 202
- Warning sounds
  - Driver's or passenger's seat belt 77
  - Exterior lighting 65, 104, 117
  - Maintenance service indicator 313
  - Parking brake 55
  - Seat belt telltale 332, 333
- Warranty coverage 411
- Washer fluid see Windshield washer fluid
- Washing the vehicle 315
- Wear pattern (tires) 308
- Weights and ratings 421
- Wheel change
  - Tightening torque 395
- Wheels
  - Tires and wheels 277
- Window curtain air bags 74
- Windows see Side windows
- Windshield
  - Defogging 188
  - Replacing wiper blades 388
  - Washer fluid 275, 430
  - Washer system 430

- Windshield defroster 180
  - Activating 181
  - Deactivating 181
- Windshield washer fluid 430
  - Message in display 365
  - Mixing ratio 430
  - Refilling 275
  - Wiping with 59
- Windshield washer system 430
- Windshield wipers 25, 58
  - Fast wiper speed 58
  - Intermittent wiping 59
  - Rear window wiper/washer 60
  - Replacing wiper blades 388
  - Single wipe 59
  - Switching on 58
  - Wiping with windshield washer fluid 59
- Winter driving 309
  - Block heater (Canada only) 310
  - Snow chains 310
  - Tires 309
- Winter driving instructions 251
- Winter tires 309

## Wiper blades

Cleaning 319

Installing 389

Removing 388

Replacing 388

## Wiper/washer

Rear window 60

## Wiping

And washing simultaneously 59

Intermittent 60

Interval 58

With windshield washer fluid 59

## Wood trims

Cleaning 322

## Service and Literature

Your authorized Mercedes-Benz Light Truck Center has trained technicians and Genuine Mercedes-Benz Parts to service your vehicle properly.

For expert advice and quality service, contact an authorized Mercedes-Benz Light Truck Center.

If you are interested in obtaining service literature for your vehicle, please contact an authorized Mercedes-Benz Light Truck Center.

We consider this the best way for you to obtain accurate information for your vehicle.

For further information you can find us on the Mercedes-Benz web-site [www.mbusa.com](http://www.mbusa.com) or [www.mercedes-benz.ca](http://www.mercedes-benz.ca).

### Warning!



To help avoid personal injury, be extremely careful when performing any service work or repairs. Improper or incomplete service or the use of incorrect or inappropriate parts or materials may damage the vehicle or its equipment, which may in turn result in personal injury.

If you have questions about carrying out any type of service, turn to the advice of an authorized Mercedes-Benz Light Truck Center.

We reserve the right to make changes in design and equipment.

Therefore, information, illustrations and descriptions in this Operator's Manual might differ from your vehicle. Reprinting, translation and copying, even of excerpts, is not permitted without our prior authorization in writing.

Press time April 12, 2007

GSP/TID

Printed in U. S. A.



